

**WESTERN - SAN BERNARDINO WATERMASTER
FOR
WESTERN MUNICIPAL WATER DISTRICT et al.
vs.
EAST SAN BERNARDINO COUNTY WATER DISTRICT et al.
CASE NO. 78426 - COUNTY OF RIVERSIDE**

VOLUME 1 - 2012

**VERIFIED EXTRACTIONS FROM THE
SAN BERNARDINO BASIN AREA
FOR
CALENDAR YEARS 1959-1963 & 2008-2012**

By Non-Plaintiffs For Use Within San Bernardino County

**ANNUAL ACCOUNTING
FOR INDIVIDUAL WELLS**

April 1, 2014

WATERMASTER
Douglas D. Headrick
John V. Rossi

REPORT OF WATERMASTER

Western Municipal Water District of Riverside County, et al.
Plaintiffs

vs.

East San Bernardino County Water District, et al.
Defendants

Superior Court of Riverside County

Case No. 78426

VOLUME 1 - 2012

VERIFIED EXTRACTIONS FROM

SAN BERNARDINO BASIN AREA

by Non-Plaintiffs For Use Within San Bernardino County

FOR

CALENDAR YEARS 1959-1963 AND 2008-2012

ANNUAL ACCOUNTING
FOR INDIVIDUAL WELLS

April 1, 2014

WATERMASTER
Douglas D. Headrick
John V. Rossi

VOLUME 1 - 2012

TABLE OF CONTENTS

	<u>Page</u>
INTRODUCTION.	i
CORRECTIONS TO THE DATABASE DURING VERIFICATION	iv
MAP OF THE SAN BERNARDINO BASIN AREA	1
GRAPH - WATER PRODUCTION BY NON-PLAINTIFFS IN SAN BERNARDINO BASIN AREA	2
SAN BERNARDINO BASIN AREA, CROSS INDEX BY OWNER.	3
SAN BERNARDINO BASIN AREA, CROSS INDEX BY STATE WELL NUMBER	26
SAN BERNARDINO BASIN AREA, CROSS INDEX BY RECORDATION NUMBER	49
CHANGE IN OWNERSHIP FROM BASE PERIOD	72
HISTORICAL FOOTNOTES - VERIFIED EXTRACTIONS BY NON-PLANTIFFS WHO HAVE FILED WITH THE WATERMASTER	84
HISTORICAL FOOTNOTES - VERIFIED EXTRACTIONS BY NON-PLANTIFFS WHO HAVE NOT FILED WITH WATERMASTER.	98
 <u>TABLE NO. 1</u>	
EXTRACTIONS BY OWNERS (NON-PLAINTIFFS) WHICH HAVE RECORDATION FILINGS WITH THE WATERMASTER.	101
 <u>TABLE NO. 2</u>	
EXTRACTIONS BY OWNERS (NON-PLAINTIFFS) WHICH HAVE NOT FILED WITH THE WATERMASTER	138
 <u>TABLE NO. 3</u>	
SUMMARY OF EXTRACTIONS (FILED AND NON-FILED) FROM SAN BERNARDINO BASIN AREA BY NON-PLAINTIFFS FOR USE WITHIN SAN BERNARDINO COUNTY	153
 <u>TABLE NO. 4</u>	
LYTLE CREEK VERIFICATION OF EXTRACTIONS FOR CALENDAR YEARS 1959-1963 & 2008-2012	164

<u>TABLE NO. 5</u>	<u>Page</u>
MILL CREEK VERIFICATION OF EXTRACTIONS FOR CALENDAR YEARS 2008-2012	175
 <u>TABLE NO. 6</u>	
SANTA ANA RIVER VERIFICATION OF EXTRACTIONS FOR CALENDAR YEARS 2008-2012	181
 <u>TABLE NO. 7</u>	
SUMMARY OF REPORTED EXTRACTIONS FROM LYTLE CREEK, MILL CREEK, AND SANTA ANA RIVER	187
 <u>TABLE NO. 8</u>	
SUMMARY OF PRODUCTION FROM SAN BERNARDINO BASIN AREA AND CORRECTION FOR VERIFIED DIVERSIONS OF MAJOR STREAMFLOWS	189
 <u>PLATE NO. 1</u>	
SCHEMATIC DIAGRAM OF LYTLE CREEK DIVERSION FACILITIES AND CONDUITS	191
 <u>PLATE NO. 1A</u>	
LOCATION MAP, LYTLE CREEK DIVERSIONS	193
 <u>PLATE NO. 2</u>	
SCHEMATIC DIAGRAM OF MILL CREEK DIVERSION FACILITIES AND CONDUITS	195
 <u>PLATE NO. 3</u>	
SCHEMATIC DIAGRAM OF SANTA ANA RIVER DIVERSION FACILITIES AND CONDUITS	197
 <u>PLATE NO. 3A</u>	
LOCATION MAP, SANTA ANA RIVER AND MILL CREEK DIVERSIONS	199
 <u>PLATE NO. 4</u>	
EAST END FACILITIES MAP	201

VOLUME 1 - 2012

VERIFIED EXTRACTIONS
FROM THE SAN BERNARDINO BASIN AREA
BY NON-PLAINTIFFS FOR USE WITHIN
SAN BERNARDINO COUNTY FOR CALENDAR YEARS
1959-1963 & 2008-2012

INTRODUCTION

The provisions of Paragraphs V(b) and VI(c) of the Judgment in Case No. 78426 entered April 17, 1969, entitled "San Bernardino Valley Replenishment," provide as follows:

V(b) "The total actual average annual extractions from the San Bernardino Basin Area by entities other than Plaintiffs for use within San Bernardino County for the five-year period ending with 1963 are assumed to be 165,407 acre-feet; the correct figure shall be determined by the Watermaster as herein provided."

VI(c) "San Bernardino Valley shall provide imported water for replenishment of the San Bernardino Basin Area at least equal to the amount by which extractions therefrom for use within San Bernardino County exceed during any five-year period the sum of: (a) five times the total average annual extractions determined under Paragraph V(b) hereof, adjusted as may be required by the natural safe yield of the San Bernardino Basin Area; and (b) any new conservation to which users within San Bernardino Valley are entitled. Such replenishment shall be supplied in the year following any five-year period; provided that during the first five-year period, San Bernardino Valley shall supply annual amounts on account of its obligations hereunder, and such amounts shall be not less than fifty percent of the gross amount of excess extractions in the previous year."

Compliance with these provisions of the Judgment requires an annual accounting of the total actual extractions of surface and groundwater within the San Bernardino Basin Area. Included in this Volume 1-2012 is the verified accounting of such production by non-plaintiff owners for the calendar year 2012. The verified production for the five-year base period ending with 1963 and the verified production for calendar years 2008, 2009, 2010, 2011 and 2012 are also included.

Three indexes are included which provide a cross index by owner's name, State Water Resources Control Board Well Recordation Number, and State Well Number. In addition and where known, each index shows the local designation of each well and the groundwater basin in which the well is located.

Tables No. 1 and No. 2 in this report list the individual wells by the owner for each year in the five-year base period ending in 1963, the five-year base period average, the extractions for the years 2008 through 2012, the five-year average for that period and the owner's total annual verified extractions. Table No. 1 lists the wells upon which filings have been made with the Watermaster, and Table No. 2 lists the wells upon which no filings have been made.

Table No. 3 is a summary of the verified extractions, by owner, as presented in Tables No. 1 and No. 2.

Table No. 4 contains the total verified Lytle Creek stream diversions by Fontana Union Water Company, West Valley Water District, City of Rialto, City of San Bernardino and Mount Vernon Water Company. The total verified Lytle Creek stream diversion takes into account, and excludes, the return flow to Lytle Creek from the Fontana Power House afterbay.

Table No. 5 of this report contains the verification of the Mill Creek stream diversions by month.

Table No. 6 contains the verification of the Santa Ana River stream diversions by month.

Table No. 7 shows the reported diversions by entity from the major streams in San Bernardino Basin Area, namely, Lytle Creek, Mill Creek and Santa Ana River. Schematic diagrams of the diversion works on each of these three major streams are shown on Plates 1, 2, and 3.

Table No. 8 shows the total Verified Production of ground and surface water within the San Bernardino Basin Area. Table No. 8 has been modified this year to add lines to:

1. Show plaintiff extractions delivered to Orange County Water District under the high groundwater mitigation agreements. Under the high groundwater mitigation agreements, some Plaintiffs extracted water from the San Bernardino Basin Area and discharged it to the Santa Ana River above Riverside Narrows. The high groundwater mitigation agreements provided for such water to be accounted for as non-plaintiff extractions from the San Bernardino Basin Area. An equal quantity of water was deducted from a

producing plaintiff's total annual extractions and export from the San Bernardino Basin Area in the same calendar year. A line was added to show the annual quantities, which commenced in 1993 and ended in 2003.

2. Show in-lieu water deliveries of imported water by Big Bear Municipal Water District to Bear Valley Mutual Water Company.

In 1977, Big Bear Municipal Water District and Bear Valley Mutual Water Company ("BVMWC") entered a stipulated Judgment in Big Bear Municipal Water District vs. North Fork Water Company et al., San Bernardino County Superior Court Case Number 165493. Under the 1977 Judgment Big Bear Municipal Water District received the right to provide a quantity of water from an alternate ("in-lieu") supply while retaining an equal quantity of water in Big Bear Lake.

In 1996, San Bernardino Valley Municipal Water District and Big Bear Municipal Water District entered an agreement for San Bernardino Valley to provide water for the in-lieu demands of BVMWC. San Bernardino Valley has generally provided imported water to BVMWC in-lieu of water being released from Big Bear Lake. The Watermaster has identified these deliveries of in-lieu water as being extractions insofar as if the water had been released from Big Bear Lake, it would have been diverted into the Southern California Edison diversion works and conveyance systems to be delivered to BVMWC and would have been considered an extraction by the Western-San Bernardino Watermaster in accordance with paragraph IV(c) of the Judgment. Deliveries of imported water prior to 1996 were made on a year to year basis as needed. A line was added to show delivery of these annual quantities, which commenced in 1981.

Non-plaintiff total extractions were recalculated from 1971 forward. The results of such recalculations are also shown in Table 2 of the Annual Report.

The total Verified Production (ground and surface water) from the San Bernardino Basin Area by non-plaintiff owners for the calendar year 2012, excluding minor production, is 177,201 acre-feet as shown on last line of Table 8.

ERRATA

Volume 1, Non-Plaintiffs, San Bernardino Basin Area

April 2014 - (The following was abstracted from the 2012 Water Extraction Report for Calendar Year, September 2013)

Changes made to CY 2012 Report

The following 3 new wells were **added** to the files this year:

- 3603964, San Bernardino Valley MWD, 9th St-North, 01S/04W-05F002S, 5/13
- 3603965, San Bernardino Valley MWD, 9th St-South, 01S/04W-05F001S, 5/13
- 3603967, Larry Jacinto Farming, Sapphire, 01S/02W-20G xxS, 6/13

The following 6 wells were **closed** during the year:

- 0000010, Batchelor, diversion, 01N/04W-14R, could not field locate
- 0000014, Boucher, , 01N/04W-14J, house has water meter but no backflow
- 0000063, Harrision Cyn, , 01N/04W-13N, house has water meter but no backflow
- 0000148, Wallace, , 01N/04W-14J, house has no water meter or backflow, assume Satoski is active well on property
- 0000153, Floyd Ward, Well #6, 01S/01W-18 M, no sign of facility on Google Earth
- 0000154, Floyd Ward, Lateral Spring #5, 01S/01W-1P, no sign of facility on Google Earth

The following **changes** were made to well data information during the year

- 0000306, City of San Bernardino, Sewer Plant #2 (originally named Blood Bank Road) corrected SW# from 01S/04W-22C to 22C04S per data from City and DWR. At one time well was also C02S. 5/13
- 3602759, City of Loma Linda, Mt View 1, 01S/04W-24A, added 01S to SW# per Loma Linda/DWR worksheet 5/13
- 3603057, City of Loma Linda, Richardson #1, 01S/04W-24C02S change to C01S per Loma Linda, DWR worksheet 5/13
- 3603058, City of Loma Linda, Richardson #2, 01S/04W-24C03S change to C02S per Loma Linda, DWR worksheet 5/13

July 2013 Changes made to prior issues of Volume 1, in
Volume 1 - 2011 Report

Table 8 has been modified to include certain additional extractions and deliveries of imported water as in-lieu water that are considered extractions

The following new wells were **added** to the files this year:

3603955, Loma Linda - City of, Richardson #5, 01S/04W-24B05S
3603956, Loma Linda - City of, Mtn. View #6, 01S/04W-24B04S
3603660, City of San Bernardino, Plant Process (Orange Show Road), 01S/04W-15P06S

The following wells were **closed** during the year:

3603141, San Bernardino Valley MWD, 9th Street, 01S/04W-04E01S

The following **changes** were made to well data information during the year:

3601003, West Valley Water District, New Raynor #4 (#13), 01S/04W-06H02S corrected from H01S per DWR well log records.
3603538, City of Rialto, City Well #4A, 01S/04W-06H04S, corrected from H03S per DWR well logs records.

The following **backfilings/corrected filings** were made during the year:

3600451, Trojan Groves (John Thomas), 01S/03W-15M, backfiled 1AF for 2010, +1 AF
3603554, 01N/03W-19A01S, Barton Development Company, 2010 corrected from 202 AF to 345 AF, +143 AF
3603655, City of Redlands, #38, 01S/03W-29Q01S, corrected 2010 production from 1,987 to 1,897 AF, number transposed -90AF
3603956, Loma Linda, City of, Mtn. View #6, 01S/04W-24B04S backfiled on 38.32 AF on First Notice, +38 AF
3603960, City of San Bernardino, Plant Process (Orange Show Road), 01S/04W-15P06S
Backfiled on First Notice
2000 through 2007 0.0 AF per year
2008 254.732 AF +255 AF
2009 20.340 AF +20 AF
2010 0.120 AF 0 AF

Table No. 4 Lytle Creek Verification of Extractions for Calendar Year 2010
Final data were obtained from the U.S. Geological Survey
2010 amounts corrected from 15,515 AF to 15,572 AF, +57 AF

Table No. 8 has been modified to include certain additional extractions and deliveries of imported water as in-lieu water that are considered extractions

July 2011 (The following was abstracted from the 2010 Water Extraction Report for Calendar Year, July 2011)

Changes made to CY 2010 Report

The following new well was **added** to the files this year

3603949, Montecito Memorial Park, #2, 01S/04W-26F. This is an old well with a common water meter for #1, 3600119

The following wells were **closed** during the year

3601297, City of Redlands, Well #17, 01S/03S-35G11S was noted demolished and filled on 02/9/11 e-mail

3602264, City of San Bernardino, 23rd Street, 01N/04W-27N01S, destroyed per 06/15/11 phone conversation with Mike Garland.

The following well was **re-opened** during the year

3602712, California State University, Ellena Bros well, 01N/04W-08P01S, reopened. Well is still equipped, just spooled off.

The following **backfilings/corrected filing** were made during the year

3600527, 01S/03W-16A, J.J. Ramirez, Midas
2009 backfiled 134.7 AF vs WM SCE estimate of 119 AF, +16 AF

0000104, 01S/02W-08A, Redlands Water Company Tunnel
2009 corrected from 1,474 AF to 654 AF, -820 AF

The following **owner name changes** were made during the year

3601649-, 01S/03W-28M, Carlos Ramirez, Hoover Well, to J.J. Ramirez

January 2011 (The following was abstracted from the Water Extraction Report for Calendar Year, December 2010)

Changes made to CY 2009 Report

The following new wells were **added** to the files this year

3603930, California State University, San Bernardino,
Irrigation Well 1, 01N/04W-17A001S

3603943, City of Redlands, Weatherwax #2, 01S/03W-15N,
leased to Redlands Farming, replaces 3600652
3603944, San Bernardino Valley Municipal Water District,
De-watering #1, 01S/04W-22C06S
3603945, San Bernardino Valley Municipal Water District,
De-watering #2, 01S/04W-22F01S

The following wells were **closed** during the year

3601930, California Dept of Mental Health, Patton 11,
01N/03W-32C02S
3602007, Bud Berman, 2, 01S/04W-02K, well casing collapsed,
well abandoned

The following **corrections or additions** were made during the year

3601639, East Valley Water District, Plant 146, SW#
corrected from 01S/03W-03R01S to R02S per 02/18/10
e-mail from DWR
3601643, East Valley Water District, Plant 121, SW#
corrected from 01S/03W-03Q01S to R01S per 02/18/10
e-mail from DWR
3604012, Baseline Gardens Mutual, Well #4, corrected SW# from
01N/01W-35R to 01N/04W-35R
3604014, now 3603946, West Valley Water District, #54
01N/06W-24C01S transferred to Volume 2
3603910, Montecito Memorial Park, Barton Road Wells,
01S/04W-27Q transferred to Volume 2

The following **backfilings/corrected filing** were made during the year

3600757, Marigold Farms, Mission #2 , 01S/03W-19L
2007 backfiled 250 AF
2008 backfiled 250 AF
2009 backfiled 250 AF

3602917, Brookside Plaza, Well 1, 01S/03W-33D01S
2008 Corrected from 0 AF to 14 AF, +14 AF

3603930, California State University, San Bernardino,
Irrigation Well 1, 01N/04W-17A01S backfiled on First Notice
2007 2 AF
2008 208 AF

3603943, City of Redlands, Weatherwax #2, 01S/03W-15N,
backfiled on First Notice
2005 51 AF
2006 58 AF
2007 69 AF
2008 32 AF

3603944, San Bernardino Valley Municipal Water District,
De-watering #1, 01S/04W-22C06S, backfiled on First Notice
2007 10 AF
2008 0 AF

3603945, San Bernardino Valley Municipal Water District, De-
watering #2, 01S/04W-22F01S, backfiled on First Notice
2007 9 AF
2008 0 AF

The following **owner name changes** were made during the year

3603933. County of San Bernardino, Glen Helen #1A (2),
01N/05W-04B, ownership name change to San Bernardino County
Parks

The following **Non-Filer to Filer status** were made during the year

0000019, San Bernardino County of, County Hospital -
Gilbert, 01N/04W-35L06S was assigned recordation number of
3603932, July 2010. SW# assigned
0000117, San Bernardino County of, County Glen Helen 3,
02N/05W-33F was assigned recordation number of 3603934,
July 2010
0000118, San Bernardino County of, County Glen Helen 4,
02N/05W-33G01S was assigned recordation number of 3603935,
July 2010, SW# assigned
0000177, San Bernardino County of, Glen Helen 1A (2),
01N/05W-04B was assigned recordation number of 3603933,
July 2010
0000179, San Bernardino County of, County Glen Helen 5,
02N/05W-33D01S was assigned recordation number of 3603936,
July 2010, SW# assigned
0000180, San Bernardino County of, County Glen Helen 6,
02N/05W-33G02S was assigned recordation number of 3603937,
July 2010, SW# assigned

The above NF numbers no longer appear in the Watermaster
Cross-Indexes.

July 2009 (The following was abstracted from the Water Extraction Report for Calendar Year, December 2009)

Changes made to CY 2008 Report

The following wells were **added** to the files this year

3603926, East Valley Water District, Well 151-Highland,
01S/03W-06L06S

3603927, City of Loma Linda, Richardson #6, 01S/04W-24L

The following wells were **closed** during the year

3600269, Mora (East Valley), Pl 68, 01N/03W-31L01S

3602897, West Valley Water District, #34, 01N/05W-23P

The following wells were **re-opened** during the year

None

The following **corrections or additions** were made during the year

0000104, Redland Water Company, 01S/02W-08A, corrected 2006
filing from 705 AF to 1,044 AF per Big Bear Watermaster.

3600241, Village Lakes, was Cram Patterson, 01S/03W-03Q, +85
AF for 2006, +85 AF for 2007

3600530-, King Street Mutual, #2, 01S/02W-30G02S, backfiled
Watermaster estimated 5 AF for 2006, +5 AF

3600530-, King Street Mutual, #2, 01S/02W-30G02S, entered 5
AF for 2007, + 5 AF.

3600865, La Bonet, Multown 2, 01N/04W-24H, entered 4 AF for
2006, + 4 AF

3600865, La Bonet, Multown 2, 01N/04W-24H, entered 4 AF for
2007, + 4 AF.

3602528, Baseline Gardens Mutual, 01N/04W-35R01S, #3
verified correction from 133 af to 424 af, +291 af for
2007

3603792, City of San Bernardino, Cajon 4, corrected SW#
from 01N/05W30A03S to 01N/05W03A03S

The following **owner name changes** were made during the year

3600269, Mora, PL68, 01N/03W-31L01S back to East Valley
Water District

3601184, North Fork Water Company, PL94/Corwin to East Valley
(not sure why it was NF).

July 2008 (The following was abstracted from the Water Extraction Report for Calendar Year, December 2008)

Changes made to CY 2007 Report

For 2006

Baseline Gardens Mutual Water Company, #3, 3602528, moved all production to this well.
Boucher, 0000014, backfiled 1 af
Break, 0000015, backfiled 1 af
Dangermond, 0000079, backfiled 1 af
King Street Mutual Well Company, 3600530-, corrected from 0 af to 5 af, field inspection, well active, + 5 af
La Bonte, 3600865, corrected from 0 af to 4 af, +4 af
Marshburn, 000081, corrected from 50 af to 100 af, SCE data shows larger usage than duty use, +50 AF
McCalla, Robert, 3601839, filing corrected from 150 af to 0 af after field inspection, -150 af
Mt. View Cemetery, 3600742-, new pump tests, correct from estimate 200AF to 115 AF, -85 af
Mt. View Cemetery, 3600743, new pump tests, correct from estimate 200AF to 129 AF, -71 af
National Orange Show, 3601924, late filing, corrected from estimated 50 af to 41 af, -9 af
Redland Strap/Skeet, 3600628 corrected from 15 af to 0 af after field inspection, no equipment, - 15 af
Redland, City of, Mentone Acres #1, 3600749 corrected from 0 af to 1,261 af, +2,236 af
Reynolds, 3600981, corrected from 5 af to 0 af, could not field locate, assumed destroyed, - 5 AF
Satoski, 0000121, backfiled 1 af, +1 af
Tilden, 3602074, corrected from 11 af to 0 af, could not field locate, assumed destroyed, - 11 af
University of Redlands, Pepper House, 0000139, corrected from 0 af to 5 af, field inspection, +5 AF
Valencia Mutual Water Company, 0000140, filing correct from 20 af to 0 af after field inspection, - 20 af
Village Lakes, 3600241, corrected from 275 af to 85 af. Had estimated duty use to include dwelling units, EVWD stated they supply domestic water, -190 af
Wallace, 0000148, backfiled 1 af, +1 af
Net increase of 1,749 AF

New wells

Calvary Chapel School, 3603603919
Mora, 3600269 back to East Valley Water District Plant #68
Unknown, Foisty Street, 0000181, located during field investigation

New data was received from Bear Valley Mutual regarding spreading at Mentone Reservoir, Judson Street and Airport (Table 6, line 14). Adjustments were made for

2004 was 0 AF corrected to 1,394 AF +1,394 AF

2005 was 931 AF corrected to 3,781 af +2,850 AF

For 2005

McCalla, Robert, 3601839, filing corrected from 150 af to 0 af after field inspection, -150 af

Redlands, City of, water production from Mentone Acres #2 (3600748) transferred to Mentone Acres #1 (3600749)

Valencia Mutual Water Company, 0000140, filing correct from 20 af to 0 af after field inspection, -20 af

Net decrease of 170 AF

For 2004

McCalla, Robert, 3601839, filing corrected from 150 af to 0 af after field inspection, -150 AF

Redland, City of, Mentone Acres #2, 3600748 corrected from 0 af to 501 af, +501 af

Valencia Mutual Water Company, 0000140, filing corrected from 20 af to 0 af after field inspection, -20 af

Net increase of 311 AF

For 2003

McCalla, Robert, 3601839, filing corrected from 150 af to 0 af after field inspection, -150 af

Redland, City of, Mentone Acres #2, 3600748 corrected from 0 af to 1,120 af, +1,120 af

Valencia Mutual Water Company, 0000140, filing corrected from 20 af to 0 af after field inspection, -20 af

Net increase of 950 AF

For 2002

McCalla, Robert, 3601839, filing corrected from 150 af to 0 af after field inspection, -150 af








Redland, City of, Mentone Acres #2, 3600748 corrected from 125 af to 1,261 af, +1,136 af

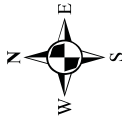
Valencia Mutual Water Company, 0000140, filing correct from 20 af to 0 af after field inspection, - 20 af

Net increase of 966 AF

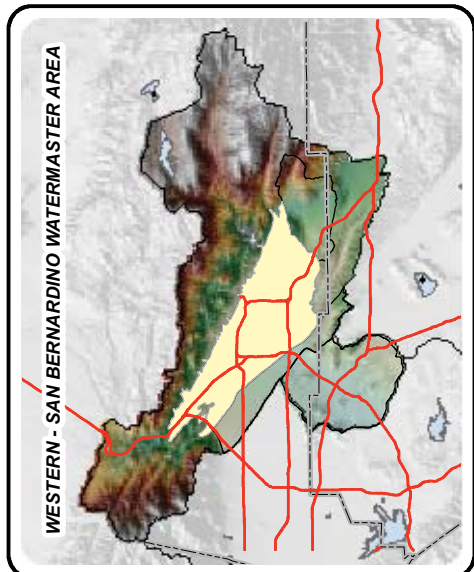
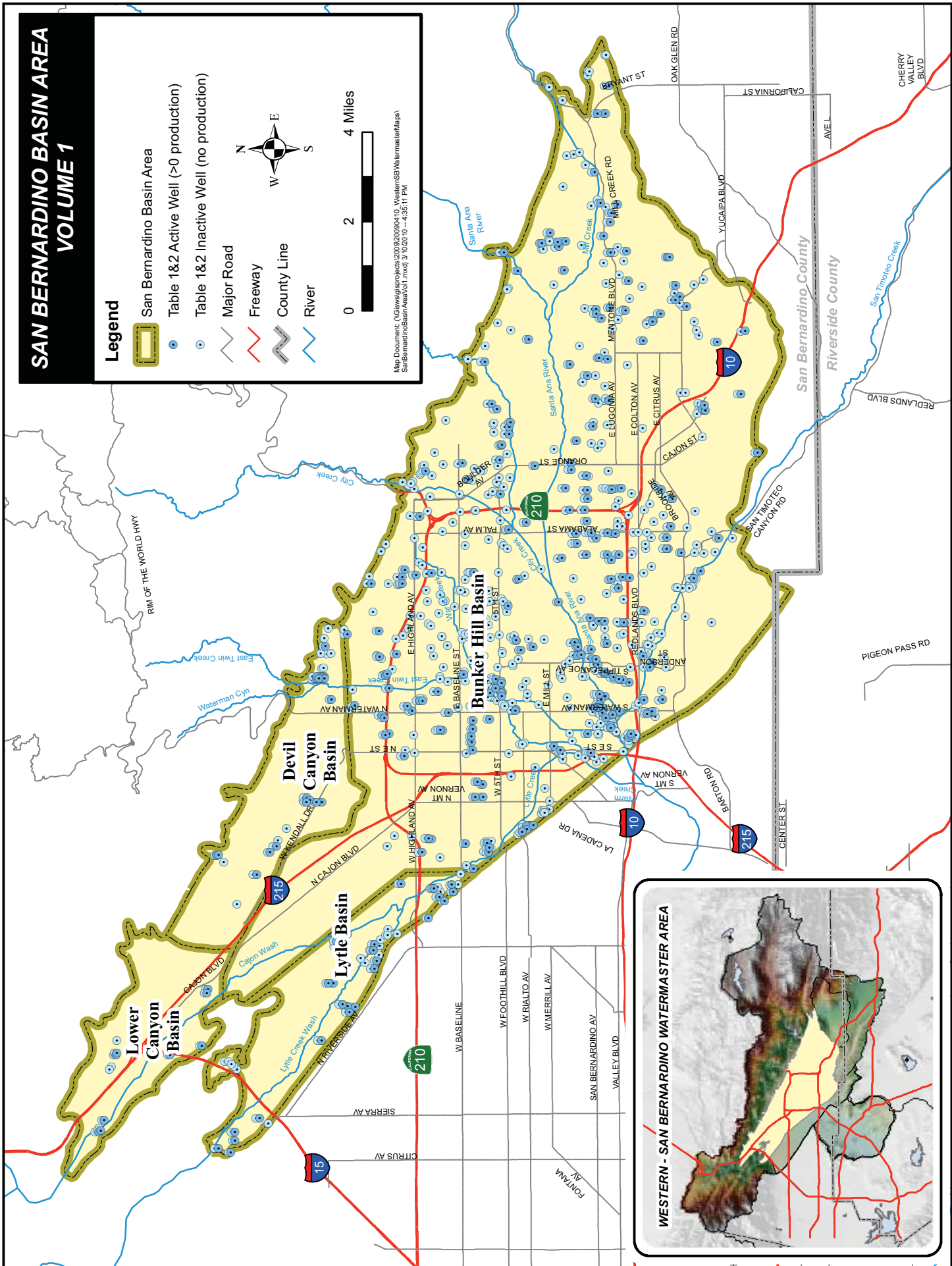
SAN BERNARDINO BASIN AREA VOLUME 1

Legend

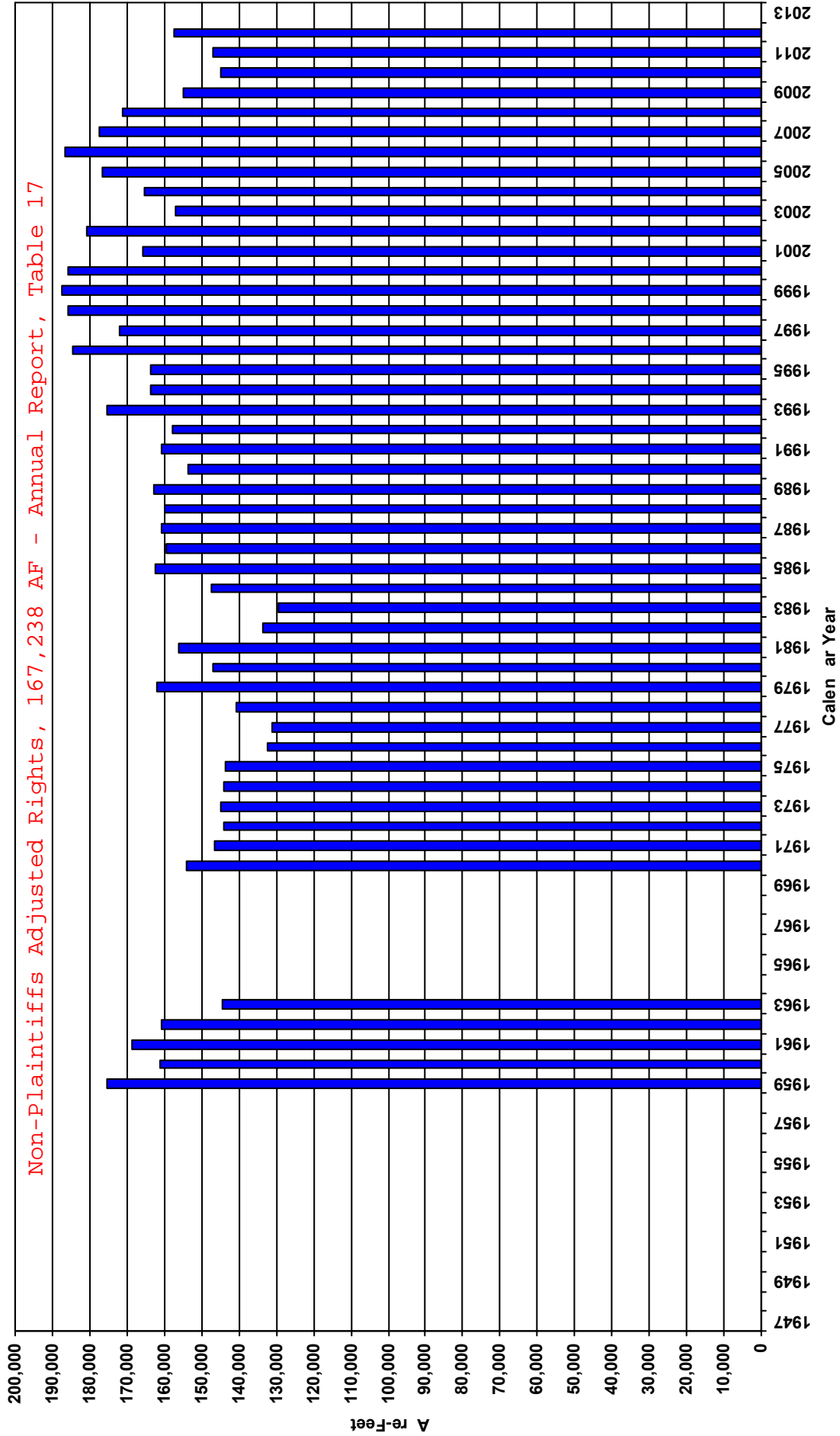
-  San Bernardino Basin Area
-  Table 1&2 Active Well (>0 production)
-  Table 1&2 Inactive Well (no production)
-  Major Road
-  Freeway
-  County Line
-  River



Map Document: (\\glw\gis\projects\2009\20090410_WesternSBWatermaster\Mapa1_SanBernardinoBasinArea\Vol1.mxd) 3/10/2010 -- 4:35:11 PM



WESTERN - SAN BERNARDINO WATERMASTER
 Mana in A en San Bernar ino Valle M ni ipal Water Distri t
 SAN BERNARDINO BASIN



SAN BERNARDINO BASIN AREA,

CROSS INDEX BY OWNER

**WESTERN - SAN BERNARDINO WATERMASTER
VERIFIED PRODUCTION DATA - NON PLAINTIFFS
CROSS INDEX BY OWNER
SAN BERNARDINO BASIN**

OWNER	WELL TYPE	RECRD TN NUMBER	STATE WELL NUMBER	LOCAL DESIGNATION	YEAR CLOSED	-----CALENDAR YEAR EXTRACTATIONS-----										
						2008	2009	2010	2011	2012	AVG					
7TH AVE WELL	W	3601121	01S/02W-31F	1	1979	0	0	0	0	0	0	0	0	0	0	
AHMANSON RANCH	W	0000002	01S/04W-27H		1988	0	0	0	0	0	0	0	0	0	0	
ANDERSON, W.D.	W	0000003	01N/04W-25R		1999	0	0	0	0	0	0	0	0	0	0	
ARMSTRONG, DOUGLAS	W	3600076	01S/03W-17G	2	1971	0	0	0	0	0	0	0	0	0	0	
ARNOLD RANCH	W	0000004	01N/03W-34H		1978	0	0	0	0	0	0	0	0	0	0	
ARROWHEAD COUNTRY CLUB	W	3601925	01N/04W-23E	1	531	472	396	385	433	443						
ARROYO VERDE MUTUAL WATER COMPANY	W	3602068	01S/04W-01A02S		2005	0	0	0	0	0	0	0	0	0	0	
ARROYO VERDE MUTUAL WATER COMPANY	W	3602069	01S/04W-01A		2005	0	0	0	0	0	0	0	0	0	0	
ATCHISON TOPEKA & SANTA FE RAILWAY	W	3600178	01S/04W-08F02S	3	1980	0	0	0	0	0	0	0	0	0	0	
ATCHISON TOPEKA & SANTA FE RAILWAY	W	3600179	01S/04W-08F	4	1980	0	0	0	0	0	0	0	0	0	0	
B M I FUNDS	W	3600107	01S/03W-21P01S	COLTON 1	1966	0	0	0	0	0	0	0	0	0	0	
BALCOM,	W	0000005	01S/04W-11M		1999	0	0	0	0	0	0	0	0	0	0	
BALDWIN,	W	0000006	01N/03W-34K		1978	0	0	0	0	0	0	0	0	0	0	
BARNO, JOHN	W	3602079	01S/03W-03F	1	1982	0	0	0	0	0	0	0	0	0	0	
BARRIER,	W	0000007	01S/04W-22B		2004	0	0	0	0	0	0	0	0	0	0	
BARTON DEVELOPMENT	W	3601748	01S/03W-18H01S	CALIF	1978	0	0	0	0	0	0	0	0	0	0	
BARTON DEVELOPMENT	W	3601748-	01S/03W-19A01S	CALIF	1996	0	0	0	0	0	0	0	0	0	0	
BARTON DEVELOPMENT C/O LUCKY FARMS	W	3600418	01S/03W-19G	LUGONIA	256	280	259	252	250	259						
BARTON DEVELOPMENT C/O LUCKY FARMS	W	3603554	01S/03W-19A01S	CALIF ST	379	215	345	336	194	294						
BASE LINE WELL COMPANY	W	3600456	01N/03W-33R02S	1	1959	0	0	0	0	0	0	0	0	0	0	
BASELINE GARDENS MUTUAL WATER COMPANY	W	3600457	01N/04W-35J02S	1 STANDBY	1992	0	0	0	0	0	0	0	0	0	0	
BASELINE GARDENS MUTUAL WATER COMPANY	W	3600458	01N/04W-36M01S	PS & B 2		0	0	0	0	0	0	0	0	0	0	
BASELINE GARDENS MUTUAL WATER COMPANY	W	3602528	01N/04W-35R01S	#3-7251 BARTON ST	2013	424	336	217	0	0	195					
BASELINE GARDENS MUTUAL WATER COMPANY	W	3604012	01N/04W-35R	WELL #4		0	0	0	0	0	0	0	0	0	0	
BASELINE LAUNDRY	W	0000008	01N/03W-31Q		1990	0	0	0	0	0	0	0	0	0	0	
BASELINE LAUNDRY	W	0000082	01N/03W-31Q		1990	0	0	0	0	0	0	0	0	0	0	
BATCHELOR,	W	0000009	01N/04W-14R		2012	1	1	1	1	1	1	1	1	1	1	
BATCHELOR,	D	0000010	01N/04W-14R		2012	1	1	1	1	1	1	1	1	1	1	
BEAR VALLEY MUTUAL WATER COMPANY	W	3600021	01N/02W-26H	SANTA A1	182	0	0	0	0	0	36					
BEAR VALLEY MUTUAL WATER COMPANY	W	3600022	01N/02W-26H	SA #2	1998	0	0	0	0	0	0	0	0	0	0	
BEAR VALLEY MUTUAL WATER COMPANY	W	3600023	01S/03W-24C	JUDSON1		0	0	0	0	0	0	0	0	0	0	
BEAR VALLEY MUTUAL WATER COMPANY	W	3600024	01S/02W-19D	WABASH 2	1974	0	0	0	0	0	0	0	0	0	0	
BEAR VALLEY MUTUAL WATER COMPANY	W	3600025	01N/03W-29R01S	PALM AV3	1977	0	0	0	0	0	0	0	0	0	0	
BEAR VALLEY MUTUAL WATER COMPANY	D	3600027	01N/02W-10N		1974	0	0	0	0	0	0	0	0	0	0	
BEAR VALLEY MUTUAL WATER COMPANY	D	3600028	01S/02W-04N	SANTA ANA RIVER MAIN		13,519	10,368	17,524	16,862	15,560	14,767					
BEAR VALLEY MUTUAL WATER COMPANY	W	3601585	01S/03W-23A03S	SBDNO AV 1 NELSON		0	0	0	0	0	0	0	0	0	0	
BELL, EUGENE	W	3600449	01S/03W-20A	CALVARY CHAPEL		108	139	73	20	1	68					

**WESTERN - SAN BERNARDINO WATERMASTER
 VERIFIED PRODUCTION DATA - NON PLAINTIFFS
 CROSS INDEX BY OWNER
 SAN BERNARDINO BASIN**

OWNER	WELL TYPE	RECRD TN NUMBER	STATE WELL NUMBER	LOCAL DESIGNATION	YEAR CLOSED	-----CALENDAR YEAR EXTRACTIONS-----					AVG
						2008	2009	2010	2011	2012	
BERMAN, BUD	W	0000011	01S/04W-02K	OLD WELL	1962	0	0	0	0	0	0
BERMAN, BUD	W	0000012	01S/04W-02J		2006	0	0	0	0	0	0
BERMAN, BUD	W	3602007	01S/04W-02K	2	2009	5	0	0	0	0	1
BLISS,	W	0000013	01S/02W-22E		1988	0	0	0	0	0	0
BLUE BANNER COMPANY	W	3602531	01S/02W-09L03S	TUNNEL DIV		100	100	100	100	50	90
BLUE GOOSE GROWERS INC	W	3602529	01S/02W-09P02S	GRNSPOT 6	1980	0	0	0	0	0	0
BLUE GOOSE GROWERS INC	W	3602530	01S/02W-09L02S	BLOCK 11	1980	0	0	0	0	0	0
BOUCHER,	W	0000014	01N/04W-14J		2012	1	1	1	1	0	1
BREAK, ALLEN ESTATE	W	0000015	01S/03W-31A			1	1	1	1	1	1
BRISTOL RANCH	W	3601631	01N/03W-34C02S	1	1972	0	0	0	0	0	0
BROOKSIDE DAIRY INC	W	3600036	01S/03W-33D	1	1989	0	0	0	0	0	0
BROOKSIDE PLAZA	W	3602917	01S/03W-33D01S	STATER BROS PLAZA		14	14	13	7	13	12
BUOYE WELL	W	3602062	01S/02W-29N	1	1977	0	0	0	0	0	0
CALIF DEPT OF MENTAL HEALTH- PLANT OPERA	W	3600923	01N/03W-32C01S	PATTON 1	1972	0	0	0	0	0	0
CALIF DEPT OF MENTAL HEALTH- PLANT OPERA	W	3600924	01N/03W-29M01S	PATTON 2	1978	0	0	0	0	0	0
CALIF DEPT OF MENTAL HEALTH- PLANT OPERA	W	3600924-	01N/03W-29M	2A		155	25	1	5	11	39
CALIF DEPT OF MENTAL HEALTH- PLANT OPERA	W	3600929	01N/03W-31K02S	PATTON 8	1967	0	0	0	0	0	0
CALIF DEPT OF MENTAL HEALTH- PLANT OPERA	W	3600931	01N/03W-29N01S	PATTON10		0	0	0	0	0	0
CALIF DEPT OF MENTAL HEALTH- PLANT OPERA	W	3601930	01N/03W-32C02S	PATTON11	2009	0	0	0	0	0	0
CALIF DEPT OF MENTAL HEALTH- PLANT OPERA	W	3602381	01N/03W-29M	14		43	28	0	0	0	14
CALIFORNIA STATE UNIVERSITY, SAN BERNARDI	W	3602712	01N/04W-08P01S	ELLENA BROS.		0	0	0	0	0	0
CALIFORNIA STATE UNIVERSITY, SAN BERNARDI	W	3603930	01N/04W-17A01S	IRRIGATION WELL 1		208	185	162	165	185	181
CALVARY CHAPEL SCHOOL	W	3603919	01S/03W-20A03S	SCHOOL IRRIGATION		10	10	10	85	85	40
CAMPUS CRUSADE FOR CHRIST	D	3601811	01N/04W-14A	EAST TWIN		3	0	0	0	0	1
CAMPUS CRUSADE FOR CHRIST	D	3601979	01N/04W-14A	EAST TWIN	1981	0	0	0	0	0	0
CAMPUS CRUSADE FOR CHRIST	D	3603938	01N/04W-14C	WEST TWIN CRK		40	40	40	40	40	40
CANYON RANCH	W	3600160	01S/03W-32G01S	GUNTER		0	0	0	0	0	0
CARDIFF FARMS MUTUAL WATER COMPANY	W	3600973	01S/04W-12D	1	1991	0	0	0	0	0	0
CARDIFF FARMS MUTUAL WATER COMPANY	W	3601619	01S/04W-12D	2	1991	0	0	0	0	0	0
CARPENTER,	W	0000016	01S/04W-22B		1971	0	0	0	0	0	0
CARTER, JAMES	W	3602241	01S/03W-20F03S	ALMOND	2007	0	0	0	0	0	0
CEMEX CONSTRUCTION MATERIALS PACIFIC, LL	W	3601420	01S/03W-09E	ALABAMA 2		184	174	174	174	184	178
CEMEX CONSTRUCTION MATERIALS PACIFIC, LL	W	3603653	01S/03W-10J	ORANGE STREET		127	79	12	0	0	44
CHARLES, J. J.	W	3600815	01S/03W-06L		1959	0	0	0	0	0	0
CITY CREEK WATER COMPANY	D	3600681	01N/03W-27M	CITY CREEK	2000	0	0	0	0	0	0
CLIFFSIDE RANCH	W	0000017	01S/03W-03F		1978	0	0	0	0	0	0
COGBILL, CLINTON L.	W	3601628	01S/02W-09Q	2		50	50	50	50	50	50

**WESTERN - SAN BERNARDINO WATERMASTER
VERIFIED PRODUCTION DATA - NON PLAINTIFFS
CROSS INDEX BY OWNER
SAN BERNARDINO BASIN**

OWNER	WELL TYPE	RECRD TN NUMBER	STATE WELL NUMBER	LOCAL DESIGNATION	YEAR CLOSED	-----CALENDAR YEAR EXTRACTIONS-----										
						2008	2009	2010	2011	2012	AVG					
COLTON, CITY OF	W	3601250	01S/04W-08F10S	4	1982	0	0	0	0	0	0	0	0	0	0	
COLTON, CITY OF	W	3601251	01S/04W-08R05S	5	2002	0	0	0	0	0	0	0	0	0	0	
COLTON, CITY OF	W	3601252	01S/04W-05R	6	1972	0	0	0	0	0	0	0	0	0	0	
COLTON, CITY OF	W	3601253	01S/04W-08Q01S	7		0	0	0	0	0	0	0	0	0	0	
COLTON, CITY OF	W	3601254	01S/04W-08F08S	8		0	0	0	0	0	0	0	0	0	0	
COLTON, CITY OF	W	3601256	01S/04W-09N	PLUNGE12	1980	0	0	0	0	0	0	0	0	0	0	
COLTON, CITY OF	W	3601257	01S/04W-08F07S	13		804	677	781	876	876	656	759				
COLTON, CITY OF	W	3601258	01S/04W-08R	14	2002	0	0	0	0	0	0	0	0	0	0	
COLTON, CITY OF	W	3601260	01S/04W-08F01S	16		449	0	287	656	836	446					
COLTON, CITY OF	W	3601262	01S/04W-08C02S	BARNHL 18	1980	0	0	0	0	0	0	0	0	0	0	
COLTON, CITY OF	W	3602405	01S/04W-08C04S	19		997	1,103	554	897	884	887					
COLTON, CITY OF	W	3602498	01S/04W-08R07S	NO 6B	2002	0	0	0	0	0	0	0	0	0	0	
COLTON, CITY OF	W	3602793	01S/04W-08F15S	WELL 21		1,797	1,816	1,032	1,438	1,879	1,592					
COLTON, CITY OF	W	3603704	01S/04W-08J02S	26		551	609	468	735	648	602					
COLTON, CITY OF	W	3603914	01S/04W-08J03S	#27		1,698	1,733	1,159	181	1,021	1,158					
COLTON, CITY OF	W	3603915	01S/04W-08F17S	#28		621	396	459	0	298	355					
CONejo RANCHOS MUTUAL WATER COMPANY	W	3601186	01N/04W-36F03S	1	1957	0	0	0	0	0	0	0	0	0	0	
COOK CANYON	D	0000018	01N/03W-27R			0	0	0	0	0	0	0	0	0	0	
CRAFTON WATER COMPANY	W	3600272	01S/02W-29N	5TH AVE, # 1		684	530	99	10	14	267					
CRAFTON WATER COMPANY	W	3600313	01S/02W-29N01S	NYE	1967	0	0	0	0	0	0	0	0	0	0	
CRAFTON WATER COMPANY	W	3602186	01S/02W-21L02S	2-GARNETIZANJA		0	0	0	0	0	0	0	0	0	0	
GRAM-PATTERSON WELL	W	3600188	01S/02W-16C	GRAMPAT2		531	596	415	415	534	498					
CRYSTAL SPRINGS	W	0000020	02S/02W-06D			1	1	1	1	1	1	1	1	1	1	
DANGERMOND, JACK	W	0000078	01S/02W-28M	LA TOURETTE	2005	0	0	0	0	0	0	0	0	0	0	
DANGERMOND, JACK	D	0000079	01S/02W-28M	SPRING DIV.		1	1	1	1	1	1	1	1	1	1	
DANGERMOND, JACK	W	3602188	01S/02W-29L	RANCHO LADERA-ESRI		215	333	0	0	0	110					
DANIELS RANCH	W	3602550	01S/03W-17R04S	ALABAMA ST	2006	0	0	0	0	0	0	0	0	0	0	
DANIELS, DON	W	0000175	01S/03W-19J		1973	0	0	0	0	0	0	0	0	0	0	
DANIELS, HAROLD	W	0000022	01S/03W-17R	RANCH	1973	0	0	0	0	0	0	0	0	0	0	
DANIELS, HAROLD	W	0000023	01S/03W-17C03S	DOMESTIC WELL	2005	0	0	0	0	0	0	0	0	0	0	
DEER PARK LLC	W	3601632	02S/03W-05A02S	CLOCK CYN		0	0	0	0	0	0	0	0	0	0	
DEL ROSA MUTUAL WATER COMPANY	W	3601809	01N/04W-26H	GOLDNAV1	1967	0	0	0	0	0	0	0	0	0	0	
DEL ROSA MUTUAL WATER COMPANY	W	3601810	01N/04W-23E	PRKSD 2	1981	0	0	0	0	0	0	0	0	0	0	
DEVORE WATER COMPANY	W	3602382	02N/05W-28D	1	1957	0	0	0	0	0	0	0	0	0	0	
DEVORE WATER COMPANY	W	3602383	02N/05W-28C02S	2A		118	137	62	71	131	104					
DEVORE WATER COMPANY	W	3602384	02N/05W-28C03S	3		93	111	69	69	121	79					
DEVORE WATER COMPANY	W	3602385	02N/05W-20H	MIDDLEMAN FALLS CK		9	8	8	9	11	9					

**WESTERN - SAN BERNARDINO WATERMASTER
VERIFIED PRODUCTION DATA - NON PLAINTIFFS
CROSS INDEX BY OWNER
SAN BERNARDINO BASIN**

OWNER	WELL TYPE	RECRD TN NUMBER	STATE WELL NUMBER	LOCAL DESIGNATION	YEAR CLOSED	-----CALENDAR YEAR EXTRACTIONS-----										AVG	
						2008	2009	2010	2011	2012							
DEVORE WATER COMPANY	W	3602386	02N/05W-21E	LETHIN SP	1968	46	31	53	66	50	49						
DEVORE WATER COMPANY	D	3602387	02N/05W-22E	E KIMBARK	1968	68	48	61	75	35	57						
DEVORE WATER COMPANY	W	3602388	02N/05W-21G	KIMBARK	1968	241	171	292	337	155	239						
DEVORE WATER COMPANY	D	3602389	02N/05W-22N	HOPPER	1968	0	0	0	0	0	0						
DEVORE WATER COMPANY	D	3602390	02N/05W-28B	SANTA FE	1968	0	0	0	0	0	0						
DEVORE WATER COMPANY	D	3602391	02N/05W-28D	CASADY	1968	0	0	0	0	0	0						
DEVORE WATER COMPANY	W	3602428	02N/05W-33E01S	4	1947	31	36	25	22	32	29						
DILLSON MUTUAL WATER COMPANY	W	0000025	01N/04W-24C	DILLSON AVE	1969	0	0	0	0	0	0						
DILLSON MUTUAL WATER COMPANY	W	0000026	01N/04W-13P	HARRISON CYN	1969	0	0	0	0	0	0						
DILLSON MUTUAL WATER COMPANY	W	0000173	01N/04W-24C	CISCO WELL	1947	0	0	0	0	0	0						
DONGLO DAIRY	W	0000021	01S/04W-11F		1947	0	0	0	0	0	0						
DUCKWORTH, JOHN E.	W	3600765	01N/03W-33C01S	113	1971	1	0	0	0	0	0						
EAST BARTON WATER COMPANY	W	3600608	01S/03W-28B01S	BARTON	1971	0	0	0	0	0	0						
EAST HIGHLAND RANCH	D	0000028	01S/02W-06Q	TUNNEL DIVERSION	1997	0	0	0	0	0	0						
EAST HIGHLAND RANCH	W	3600598	01S/03W-02L	NEW 1	1986	0	0	0	0	0	0						
EAST HIGHLAND RANCH	W	3600604	01S/02W-07B	RANNEY	1986	0	0	0	0	0	0						
EAST HIGHLAND RANCH	D	3600605	01N/03W-35G	PLUNGE CK	1980	0	0	0	0	0	0						
EAST HIGHLAND RANCH	D	3600606	01N/03W-35K	ELDER GULCH	1991	0	0	0	0	0	0						
EAST HIGHLAND RANCH	W	3600607	01S/03W-02L01S	SMALL	1978	0	0	0	0	0	0						
EAST HIGHLAND RANCH	W	3600607	01S/03W-02L02S	WELL 3	1991	0	0	0	0	0	0						
EAST HIGHLAND RANCH	D	3602474	01N/03W-25Q	PLUNGE/BOX SPRING	2004	0	0	0	0	0	0						
EAST HIGHLANDS ORANGE COMPANY	D	0000029	01N/03W-35B	BOX SPRING	1980	0	0	0	0	0	0						
EAST PIONEER MUTUAL WELL COMPANY	W	3602224	01S/03W-13P		1991	0	0	0	0	0	0						
EAST VALLEY WATER DISTRICT	W	0000030	01N/03W-30C	PLANT NO 36	1958	0	0	0	0	0	0						
EAST VALLEY WATER DISTRICT	W	0000032	01S/03W-04P	PLANT NO 43	2005	0	0	0	0	0	0						
EAST VALLEY WATER DISTRICT	W	0000033	01S/03W-05R	PLANT NO 44	2005	0	0	0	0	0	0						
EAST VALLEY WATER DISTRICT	W	0000034	01N/03W-31A	PLANT NO 45	2005	0	0	0	0	0	0						
EAST VALLEY WATER DISTRICT	W	0000035	01S/03W-05Q	PLANT NO 46	2005	0	0	0	0	0	0						
EAST VALLEY WATER DISTRICT	W	0000036	01N/04W-36H	PLANT NO 52	2005	0	0	0	0	0	0						
EAST VALLEY WATER DISTRICT	W	0000037	01S/03W-06Q	PLANT NO 69	2005	0	0	0	0	0	0						
EAST VALLEY WATER DISTRICT	W	0000038	01N/03W-31D	PLANT NO 70	2005	0	0	0	0	0	0						
EAST VALLEY WATER DISTRICT	W	0000039	01S/03W-06E	PLANT NO 71	2005	0	0	0	0	0	0						
EAST VALLEY WATER DISTRICT	W	0000040	01S/03W-06B	PLANT NO 72	2005	0	0	0	0	0	0						
EAST VALLEY WATER DISTRICT	W	0000041	01S/03W-06C	PLANT NO 74	2005	0	0	0	0	0	0						
EAST VALLEY WATER DISTRICT	W	0000042	01S/04W-02L	PLANT NO 75	2005	0	0	0	0	0	0						
EAST VALLEY WATER DISTRICT	W	0000043	01S/03W-06P	PLANT NO 78	2005	0	0	0	0	0	0						
EAST VALLEY WATER DISTRICT	W	0000044	01S/03W-05Q	PLANT NO 80	2005	0	0	0	0	0	0						

**WESTERN - SAN BERNARDINO WATERMASTER
VERIFIED PRODUCTION DATA - NON PLAINTIFFS
CROSS INDEX BY OWNER
SAN BERNARDINO BASIN**

OWNER	WELL TYPE	RECRD TN NUMBER	STATE WELL NUMBER	LOCAL DESIGNATION	YEAR CLOSED	-----CALENDAR YEAR EXTRACTIONS-----										
						2008	2009	2010	2011	2012	AVG					
EAST VALLEY WATER DISTRICT	W	0000045	01S/03W-06M	PLANT NO 81	2005	0	0	0	0	0	0	0	0	0	0	
EAST VALLEY WATER DISTRICT	W	0000046	01S/03W-06Q	PLANT NO 83	2005	0	0	0	0	0	0	0	0	0	0	
EAST VALLEY WATER DISTRICT	W	0000047	01S/03W-03N	PLANT NO 84	2005	0	0	0	0	0	0	0	0	0	0	
EAST VALLEY WATER DISTRICT	W	0000048	01N/04W-25D	PLANT NO 85	2005	0	0	0	0	0	0	0	0	0	0	
EAST VALLEY WATER DISTRICT	W	0000049	01S/03W-03N	PLANT NO 93	2005	0	0	0	0	0	0	0	0	0	0	
EAST VALLEY WATER DISTRICT	W	0000050	01S/03W-05J	PLANT NO 95	2005	0	0	0	0	0	0	0	0	0	0	
EAST VALLEY WATER DISTRICT	W	0000051	01S/04W-01D	PLANT NO 96	2005	0	0	0	0	0	0	0	0	0	0	
EAST VALLEY WATER DISTRICT	W	0000052	01S/03W-06N	PLANT NO 97	2005	0	0	0	0	0	0	0	0	0	0	
EAST VALLEY WATER DISTRICT	W	0000059	01S/03W-04Q	PLANT NO 106	1974	0	0	0	0	0	0	0	0	0	0	
EAST VALLEY WATER DISTRICT	W	0000076	01S/03W-06L	LANKERSHIM A	2005	0	0	0	0	0	0	0	0	0	0	
EAST VALLEY WATER DISTRICT	W	0000077	01S/03W-06F	MCKINLEY ST.	2005	0	0	0	0	0	0	0	0	0	0	
EAST VALLEY WATER DISTRICT	W	3600058	01S/03W-03F02S	PL 53 / EUCALYPTUS	2001	0	0	0	0	0	0	0	0	0	0	
EAST VALLEY WATER DISTRICT	W	3600183	01S/04W-02A	PL 60	2003	0	0	0	0	0	0	0	0	0	0	
EAST VALLEY WATER DISTRICT	W	3600220	01S/03W-01H01S	PLANT #142 / MT. H	425	445	624	503	600	519						
EAST VALLEY WATER DISTRICT	W	3600221	01N/03W-30J	PL 63	2001	0	0	0	0	0	0	0	0	0	0	
EAST VALLEY WATER DISTRICT	W	3600269	01N/03W-31L01S	PL 68	2007	0	0	0	0	0	0	0	0	0	0	
EAST VALLEY WATER DISTRICT	W	3600275	01N/03W-32B	PL 64	2003	0	0	0	0	0	0	0	0	0	0	
EAST VALLEY WATER DISTRICT	W	3600374	01N/03W-33M01S	PL 138/PALM 1	2000	0	0	0	0	0	0	0	0	0	0	
EAST VALLEY WATER DISTRICT	W	3600375	01S/03W-05D	PL 132/CULL 1	2000	0	0	0	0	0	0	0	0	0	0	
EAST VALLEY WATER DISTRICT	W	3600376	01S/03W-05D03S	PL 132/CULL 2	2000	0	0	0	0	0	0	0	0	0	0	
EAST VALLEY WATER DISTRICT	W	3600377	01N/03W-27N08S	PL 134/CC1	2003	0	0	0	0	0	0	0	0	0	0	
EAST VALLEY WATER DISTRICT	W	3600378	01N/03W-27N02S	PL 134/CC3	2003	0	0	0	0	0	0	0	0	0	0	
EAST VALLEY WATER DISTRICT	W	3600444	01N/03W-30H01S	PL 98	2000	0	0	0	0	0	0	0	0	0	0	
EAST VALLEY WATER DISTRICT	W	3600466	01S/03W-04C	PL 48	2000	0	0	0	0	0	0	0	0	0	0	
EAST VALLEY WATER DISTRICT	W	3600545	01N/03W-30J	PL 62	2003	0	0	0	0	0	0	0	0	0	0	
EAST VALLEY WATER DISTRICT	W	3600643	01N/04W-25K01S	PL 66	2003	0	0	0	0	0	0	0	0	0	0	
EAST VALLEY WATER DISTRICT	W	3600680	01S/03W-02J02S	PL 120 / CRAM	1,482	500									396	
EAST VALLEY WATER DISTRICT	W	3600855	01N/03W-28P01S	PL 54	2003	0	0	0	0	0	0	0	0	0	0	
EAST VALLEY WATER DISTRICT	W	3600864	01N/03W-19F	PL 79	2003	0	0	0	0	0	0	0	0	0	0	
EAST VALLEY WATER DISTRICT	W	3600925	01S/04W-01Q01S	PL 100	2003	0	0	0	0	0	0	0	0	0	0	
EAST VALLEY WATER DISTRICT	W	3600926	01S/04W-01F02S	PL 115	2003	0	0	0	0	0	0	0	0	0	0	
EAST VALLEY WATER DISTRICT	W	3600927	01N/03W-31B01S	PL 116	2003	0	0	0	0	0	0	0	0	0	0	
EAST VALLEY WATER DISTRICT	W	3600928	01N/03W-31L02S	PL 117	2003	0	0	0	0	0	0	0	0	0	0	
EAST VALLEY WATER DISTRICT	W	3600930	01N/03W-31L03S	PL 118	2003	0	0	0	0	0	0	0	0	0	0	
EAST VALLEY WATER DISTRICT	W	3600970	01N/03W-19G	PL 57	2000	0	0	0	0	0	0	0	0	0	0	
EAST VALLEY WATER DISTRICT	W	3600971	01N/03W-19F	PL 58/LT SAND CK	2000	0	0	0	0	0	0	0	0	0	0	
EAST VALLEY WATER DISTRICT	W	3601069	01N/03W-33M02S	CHURCH	1987	0	0	0	0	0	0	0	0	0	0	

**WESTERN - SAN BERNARDINO WATERMASTER
 VERIFIED PRODUCTION DATA - NON PLAINTIFFS
 CROSS INDEX BY OWNER
 SAN BERNARDINO BASIN**

OWNER	WELL TYPE	RECRD TN NUMBER	STATE WELL NUMBER	LOCAL DESIGNATION	YEAR CLOSED	-----CALENDAR YEAR EXTRACTATIONS-----										
						2008	2009	2010	2011	2012	AVG					
EAST VALLEY WATER DISTRICT	W	3601184	01N/03W-33F01S	PL 94 / CORWIN		0	0	0	0	0	0	0	0	0	0	
EAST VALLEY WATER DISTRICT	W	3601582	01S/04W-02R	PL 119	2003	0	0	0	0	0	0	0	0	0	0	
EAST VALLEY WATER DISTRICT	W	3601584	01N/03W-33H01S	PL 47	2003	0	0	0	0	0	0	0	0	0	0	
EAST VALLEY WATER DISTRICT	W	3601639	01S/03W-03R02S	PL 146 / 2		218	184	308	336	178	245					
EAST VALLEY WATER DISTRICT	W	3601643	01S/03W-03R01S	PL 121	2003	0	0	0	0	0	0	0	0	0	0	
EAST VALLEY WATER DISTRICT	W	3601653	01N/04W-36K04S	PL 1	2000	0	0	0	0	0	0	0	0	0	0	
EAST VALLEY WATER DISTRICT	W	3601654	01N/04W-36K	PL 1A / FISHER	2000	0	0	0	0	0	0	0	0	0	0	
EAST VALLEY WATER DISTRICT	W	3601655	01N/04W-36K05S	PL 2	2000	0	0	0	0	0	0	0	0	0	0	
EAST VALLEY WATER DISTRICT	W	3601656	01N/04W-36Q01S	PL 6	2003	0	0	0	0	0	0	0	0	0	0	
EAST VALLEY WATER DISTRICT	W	3601657	01S/04W-01B04S	PL 7	2000	0	0	0	0	0	0	0	0	0	0	
EAST VALLEY WATER DISTRICT	W	3601658	01N/04W-36R10S	PL 8	2003	0	0	0	0	0	0	0	0	0	0	
EAST VALLEY WATER DISTRICT	W	3601659	01S/03W-06H01S	PL 9	2000	0	0	0	0	0	0	0	0	0	0	
EAST VALLEY WATER DISTRICT	W	3601660	01S/03W-06H04S	PL 9A		1,224	737	934	813	683	878					
EAST VALLEY WATER DISTRICT	W	3601661	01S/04W-01J08S	PL 10	2003	0	0	0	0	0	0	0	0	0	0	
EAST VALLEY WATER DISTRICT	W	3601662	01S/04W-02Q05S	PL 11	2000	0	0	0	0	0	0	0	0	0	0	
EAST VALLEY WATER DISTRICT	W	3601663	01S/04W-02Q04S	PL 12		0	0	0	0	0	0	0	0	0	0	
EAST VALLEY WATER DISTRICT	W	3601664	01S/04W-02N01S	PL 13	2003	0	0	0	0	0	0	0	0	0	0	
EAST VALLEY WATER DISTRICT	W	3601665	01S/04W-01K04S	PL 14		0	0	0	0	0	0	0	0	0	0	
EAST VALLEY WATER DISTRICT	W	3601666	01N/04W-36F08S	PL 16	2003	0	0	0	0	0	0	0	0	0	0	
EAST VALLEY WATER DISTRICT	W	3601667	01S/03W-06A05S	PL 21	2000	0	0	0	0	0	0	0	0	0	0	
EAST VALLEY WATER DISTRICT	W	3601668	01S/04W-01E02S	PL 22	2000	0	0	0	0	0	0	0	0	0	0	
EAST VALLEY WATER DISTRICT	W	3601669	01N/04W-36H06S	PL 23	2000	0	0	0	0	0	0	0	0	0	0	
EAST VALLEY WATER DISTRICT	W	3601670	01N/04W-26A10S	PL 24	2000	0	0	0	0	0	0	0	0	0	0	
EAST VALLEY WATER DISTRICT	W	3601671	01N/04W-26A02S	PL 24A		415	330	416	1,063	784	602					
EAST VALLEY WATER DISTRICT	W	3601672	01N/04W-25B	PL 25	2000	0	0	0	0	0	0	0	0	0	0	
EAST VALLEY WATER DISTRICT	W	3601673	01N/04W-25C02S	PL 25A		250	128	333	646	790	429					
EAST VALLEY WATER DISTRICT	W	3601674	01N/04W-25G01S	PL 26		0	0	0	0	0	0	0	0	0	0	
EAST VALLEY WATER DISTRICT	W	3601675	01N/04W-25A01S	PL 27	2003	805	510	211	1	0	305					
EAST VALLEY WATER DISTRICT	W	3601676	01S/04W-12B05S	PL 28	2000	0	0	0	0	0	0	0	0	0	0	
EAST VALLEY WATER DISTRICT	W	3601677	01S/03W-05A02S	PL 31	2000	0	0	0	0	0	0	0	0	0	0	
EAST VALLEY WATER DISTRICT	W	3601678	01S/03W-05B04S	PL 32	2000	0	0	0	0	0	0	0	0	0	0	
EAST VALLEY WATER DISTRICT	W	3601679	01S/03W-05N05S	PL 38	2003	0	0	0	0	0	0	0	0	0	0	
EAST VALLEY WATER DISTRICT	W	3601781	01S/03W-06K01S	PL35/BASELINE MUTUAL	2003	0	0	0	0	0	0	0	0	0	0	
EAST VALLEY WATER DISTRICT	W	3601884	01N/03W-31C02S	PL 30	2000	0	0	0	0	0	0	0	0	0	0	
EAST VALLEY WATER DISTRICT	W	3601978	01S/03W-04N01S	PL 40		0	0	0	0	0	0	0	0	0	0	
EAST VALLEY WATER DISTRICT	W	3601987	01S/03W-04G02S	PL 136 / DUNKIRK 1		0	0	0	0	0	0	0	0	0	0	
EAST VALLEY WATER DISTRICT	W	3602034	01S/04W-01Q08S	PL 12A		210	2	1	1	1	43					

**WESTERN - SAN BERNARDINO WATERMASTER
VERIFIED PRODUCTION DATA - NON PLAINTIFFS
CROSS INDEX BY OWNER
SAN BERNARDINO BASIN**

OWNER	WELL TYPE	RECRD TN NUMBER	STATE WELL NUMBER	LOCAL DESIGNATION	YEAR CLOSED	-----CALENDAR YEAR EXTRACTIONS-----										
						2008	2009	2010	2011	2012	AVG					
EAST VALLEY WATER DISTRICT	W	3602113	01N/03W-30N01S	PL 41		0	0	0	0	0	0	0	0	0	0	
EAST VALLEY WATER DISTRICT	W	3602174	01S/04W-02A05S	PL 105 / MYERS	2000	0	0	0	0	0	0	0	0	0	0	
EAST VALLEY WATER DISTRICT	W	3602260	01S/03W-05D06S	PL 132 / CULL#3	2004	0	0	0	0	0	0	0	0	0	0	
EAST VALLEY WATER DISTRICT	W	3602274	01N/03W-30J05S	PL 39		921	1,084	937	1,086	896	985					
EAST VALLEY WATER DISTRICT	W	3602337	01N/04W-26A03S	PL 24B		1,818	1,355	398	46	1,683	1,060					
EAST VALLEY WATER DISTRICT	W	3602338	01S/03W-04N03S	PL 40A		0	23	1,009	441	499	394					
EAST VALLEY WATER DISTRICT	W	3602370	01N/04W-25C04S	PL 107		499	1,342	1,399	926	954	1,024					
EAST VALLEY WATER DISTRICT	W	3602417	01S/03W-05D07S	PL 132 / CULL #4	2004	0	0	0	0	0	0	0	0	0	0	
EAST VALLEY WATER DISTRICT	W	3602560	01S/03W-04G03S	PL 136 / DUNKIRK#2		0	0	0	0	0	0	0	0	0	0	
EAST VALLEY WATER DISTRICT	W	3602563	01S/04W-02Q10S	PL 11A		1,546	1,911	1,629	1,288	1,028	1,480					
EAST VALLEY WATER DISTRICT	W	3602564	01S/04W-12B07S	PL 28A		2,560	2,491	2,429	1,623	1,445	2,110					
EAST VALLEY WATER DISTRICT	W	3602571	01S/03W-03F02S	PL 122	2000	0	0	0	0	0	0	0	0	0	0	
EAST VALLEY WATER DISTRICT	W	3602799	01S/02W-07F01S	PL 125		1,134	965	845	1,412	1,447	1,161					
EAST VALLEY WATER DISTRICT	W	3603247	01S/03W-06P18S	PL 141		1,653	808	1,056	1,535	1,668	1,344					
EAST VALLEY WATER DISTRICT	W	3603583	01S/03W-02N02S	PLANT 143		617	895	981	620	966	816					
EAST VALLEY WATER DISTRICT	W	3603734	01S/03W-02P06S	PLANT 147		1,768	1,539	1,738	2,004	1,717	1,753					
EAST VALLEY WATER DISTRICT	W	3603774	01S/03W-03R04S	146A - 7938 CHURCH		1,010	880	228	168	871	631					
EAST VALLEY WATER DISTRICT	W	3603904	01S/03W-05D09S	132-5		2,032	1,544	835	1,479	924	1,363					
EAST VALLEY WATER DISTRICT	W	3603926	01S/03W-06L06S	WELL 151-HIGHLAND		0	1,748	1,809	2,417	2,404	1,676					
EAST VALLEY WATER DISTRICT	W	3692174	01S/04W-02A	PL 105	1984	0	0	0	0	0	0	0	0	0	0	
EASTWOOD FARMS COMMUNITY WATER USERS	W	3602130	01S/04W-01P01S	1	2002	0	0	0	0	0	0	0	0	0	0	
EASTWOOD FARMS COMMUNITY WATER USERS	W	3602131	01S/04W-01P02S	2	2002	0	0	0	0	0	0	0	0	0	0	
ELLENA, JOHN B.	W	0000054	01N/04W-08N		1977	0	0	0	0	0	0	0	0	0	0	
ELLGOOD,	W	0000055	01S/02W-24C			0	0	0	0	0	0	0	0	0	0	
ELTINGE & GRAZIADIO	W	3600766	01S/03W-29A01S	COLTAMA	1971	0	0	0	0	0	0	0	0	0	0	
FAIRVIEW WATER COMPANY	W	3600554	01S/03W-17R	FAIRVW 1		266	286	102	80	71	161					
FAR WELL	W	3602020	01S/02W-20K	F A R		74	70	29	0	0	35					
FARROW,	W	0000056	01S/02W-22E			5	5	5	5	5	5					
FINCH,	W	0000057	01S/02W-29C	FINCH	2004	0	0	0	0	0	0	0	0	0	0	
FONTANA UNION WATER COMPANY	W	3600561	01N/05W-23K01S	FU 1	1987	0	0	0	0	0	0	0	0	0	0	
FONTANA UNION WATER COMPANY	W	3600562	01N/05W-22F02S	FU 3		1,361	1,018	653	1,303	1,747	1,216					
FONTANA UNION WATER COMPANY	W	3600563	01N/05W-22C02S	FU 4		1,501	1,274	922	1,976	2,272	1,589					
FONTANA UNION WATER COMPANY	W	3600566	01N/05W-15Q02S	FU 8	1962	0	0	0	0	0	0	0	0	0	0	
FONTANA UNION WATER COMPANY	W	3600569	01N/05W-22A01S	FU 13		2,512	2,161	1,360	1,585	2,586	2,041					
FONTANA UNION WATER COMPANY	W	3600579	01N/05W-22F03S	FU 24		624	715	950	871	1,308	894					
FONTANA UNION WATER COMPANY	W	3600580	01N/05W-22F01S	FU 25		222	0	0	0	0	44					
FONTANA UNION WATER COMPANY	W	3600581	01N/05W-07H01S	FU 26		385	57	855	1,001	903	640					

**WESTERN - SAN BERNARDINO WATERMASTER
VERIFIED PRODUCTION DATA - NON PLAINTIFFS
CROSS INDEX BY OWNER
SAN BERNARDINO BASIN**

OWNER	WELL TYPE	RECRD TN NUMBER	STATE WELL NUMBER	LOCAL DESIGNATION	YEAR CLOSED	-----CALENDAR YEAR EXTRACTIONS-----										
						2008	2009	2010	2011	2012	AVG					
FONTANA UNION WATER COMPANY	W	3600582	01N/05W-06G01S	FU 27		419	121	170	255	1	193					
FONTANA UNION WATER COMPANY	W	3600585	01N/05W-16K01S	FU 32		852	778	1,135	1,435	1,352	1,110					
FONTANA UNION WATER COMPANY	W	3600586	01N/05W-06K02S	FU 33		1,482	1,559	1,028	553	1,382	1,201					
FONTANA UNION WATER COMPANY	W	3600588	02N/06W-26L02S	MILLER NARROWS #1	1981	0	0	0	0	0	0					
FONTANA UNION WATER COMPANY	W	3600590	02N/06W-26L01S	MIL NAR 2	1986	0	0	0	0	0	0					
FONTANA UNION WATER COMPANY	W	3600591	01N/05W-06E	BL AND FTF	1992	0	0	0	0	0	0					
FONTANA UNION WATER COMPANY	W	3602727	01N/05W-15Q02S	FU 8		1,165	106	1	595	1,054	584					
FRIEDEMANN, ERNEST C.	W	3600747	01N/03W-31P02S	WELL 1	1971	0	0	0	0	0	0					
FRINK RANCH	W	3601131	01S/03W-30K	1	1958	0	0	0	0	0	0					
GAY GROVE	W	3601126	01S/02W-30H	1		40	55	39	32	38	41					
GENERAL AMERICAN LIFE	W	3601352	01S/03W-19N	LANGFORD		62	62	62	62	62	62					
GLADYSTA WELL & WATER COMPANY	W	3600182	01S/03W-20H01S	1	1978	0	0	0	0	0	0					
GLADYSTA WELL & WATER COMPANY	W	3600182-	01S/03W-20H02S			51	65	88	99	143	89					
GOLCONDA WATER COMPANY	W	0000058	01S/04W-13E		1969	0	0	0	0	0	0					
GOLDEN BEAR FOREST PRODUCTS	W	3602127	01S/03W-15A01S	1	1991	0	0	0	0	0	0					
GRANT WATER COMPANY	W	3600075	01S/03W-28C01S	GRANT	1991	0	0	0	0	0	0					
GREENSPOT MUTUAL WATER CO. TUNNEL	D	0000166	01S/02W-22C			50	50	50	50	50	50					
GREENSPOT MUTUAL WELL COMPANY	W	3600266	01S/02W-16C01S	GRNSPTMU		215	311	141	138	188	199					
GREENSPOT VILLAGE & MARKET PLACE LLC	W	3600026	01S/03W-04J01S	PL 102		0	0	0	0	0	0					
GUERTH, WILLIAM H.	D	3600856	01N/03W-27M	CITY CREEK	1967	0	0	0	0	0	0					
HAGAR,	W	0000060	01S/02W-16L		2007	0	0	0	0	0	0					
HAPPE MUTUAL WELL COMPANY	W	3600238	01S/02W-29M01S	1		24	97	71	79	63	67					
HARDISON,	W	0000061	01N/04W-13Q	KING STREET MUTUAL		1	1	1	1	1	1					
HARRISON CANYON	W	0000063	01N/04W-13N		2012	0	0	0	0	0	0					
HARRISON CANYON	W	0000064	01N/04W-13N			0	0	0	0	0	1					
HARRISON,	W	0000062	01S/03W-04J01S		2007	0	0	0	0	0	0					
HAZAS,	W	0000065	01S/04W-11G		1999	0	0	0	0	0	0					
HEAD, JOE T.	W	3600226	01S/02W-21L01S	1	1960	0	0	0	0	0	0					
HELIPORT	W	0000066	01S/04W-15G		2005	0	0	0	0	0	0					
HIGHLAND ACRES RANCH	W	3600323	01S/02W-06M	ELEC 1	1998	0	0	0	0	0	0					
HIGHLAND WELL COMPANY	W	3600184	01N/03W-28N01S	HWC 1	1974	0	0	0	0	0	0					
HILL,	W	0000067	01S/02W-31B		2004	0	0	0	0	0	0					
HINCKLEY, HORACE P.	W	3600240	01S/02W-30B	SOUTH WELL	1982	0	0	0	0	0	0					
HINCKLEY, HORACE P.	W	3601645	01S/02W-30B	1	1982	0	0	0	0	0	0					
HOLDEN MUTUAL WATER COMPANY	W	0000068	01S/04W-14E		1999	0	0	0	0	0	0					
HOLDEN MUTUAL WATER COMPANY	W	0000069	01S/04W-14F	HOLDEN AVE.	1999	0	0	0	0	0	0					
HOLLIDAY TRUCKING	W	3603262	01N/04W-31M03S	SB #1		59	61	59	60	60	60					

**WESTERN - SAN BERNARDINO WATERMASTER
VERIFIED PRODUCTION DATA - NON PLAINTIFFS
CROSS INDEX BY OWNER
SAN BERNARDINO BASIN**

OWNER	WELL TYPE	RECRD TN NUMBER	STATE WELL NUMBER	LOCAL DESIGNATION	YEAR CLOSED	-----CALENDAR YEAR EXTRACTIONS-----							
						2008	2009	2010	2011	2012	AVG		
HOLMES ICE & COLD STORAGE	W	3600644	01S/04W-09B03S	2	2003	0	0	0	0	0	0	0	0
HOLMES ICE & COLD STORAGE	W	3600645	01S/04W-09B01S		1960	0	0	0	0	0	0	0	0
HOOVER WELL	W	3601649	01S/03W-28M	HOOVER	1978	0	0	0	0	0	0	0	0
HORTON,	W	0000070	01S/03W-32J	LA PAPER BOX		248	315	267	222	356	282		
HUNTER,	W	0000071	01S/03W-03D		1978	0	0	0	0	0	0	0	0
INLAND VALLEY DEVELOPMENT AGENCY	W	0000086	01S/04W-07D	LOCAL NO. 2	1997	0	0	0	0	0	0	0	0
INLAND VALLEY DEVELOPMENT AGENCY	W	0000087	01S/04W-12C	LOCAL NO. 3	1997	0	0	0	0	0	0	0	0
INLAND VALLEY DEVELOPMENT AGENCY	W	0000088	01S/04W-12D	LOCAL NO. 4	2005	0	0	0	0	0	0	0	0
INLAND VALLEY DEVELOPMENT AGENCY	W	0000089	01S/04W-12F	LOCAL NO. 5	1997	0	0	0	0	0	0	0	0
INLAND VALLEY DEVELOPMENT AGENCY	W	0000090	01S/03W-07A	LOCAL NO.11	1997	0	0	0	0	0	0	0	0
INLAND VALLEY DEVELOPMENT AGENCY	W	0000091	01S/04W-12Q	NO NO. WELL	2005	0	0	0	0	0	0	0	0
INLAND VALLEY DEVELOPMENT AGENCY	W	0000092	01S/04W-12G	LOCAL NO. 44	2005	0	0	0	0	0	0	0	0
INLAND VALLEY DEVELOPMENT AGENCY	W	0000093	01S/03W-08E	LOCAL NO.347	2005	0	0	0	0	0	0	0	0
INLAND VALLEY DEVELOPMENT AGENCY	W	0000094	01S/03W-08M	LOCAL NO.865	2005	0	0	0	0	0	0	0	0
INLAND VALLEY DEVELOPMENT AGENCY	W	3603646	01S/03W-07D	NORTON #2A		0	0	0	0	0	0	0	0
INLAND VALLEY DEVELOPMENT AGENCY	W	3603647	01S/04W-12C01S	NORTON #3		0	0	0	0	0	0	0	0
INLAND VALLEY DEVELOPMENT AGENCY	W	3603648	01S/04W-12F	NORTON #5		0	0	0	0	0	0	0	0
INLAND VALLEY DEVELOPMENT AGENCY	W	3603650	01S/03W-18C	NORTON GOLF COURSE		75	0	0	0	0	0	0	15
INTER CITY MUTUAL WATER COMPANY	W	0000072	01S/04W-23P		1977	0	0	0	0	0	0	0	0
IOWA STREET WELL	W	3601932	01S/03W-29B01S		1974	0	0	0	0	0	0	0	0
J. G. GOLFING ENTERPRISES	W	3602499	01S/04W-22A01S	PAYNE H 25		206	251	304	196	192	230		
J. G. GOLFING ENTERPRISES	W	3602846	01S/04W-22A01S	THORN 10 & 11		469	319	282	394	439	381		
JACINTO FARMING, LARRY	W	3603967	01S/02W-20G	SAPPHIRE								1	0
JEWEL WATER COMPANY	W	3600091	01S/03W-20R	1	1976	0	0	0	0	0	0	0	0
JUDSON MUTUAL WATER COMPANY	W	3601647	01S/03W-23A03S	1	1982	0	0	0	0	0	0	0	0
K INV/ EVCA/ Y UN WELL	W	3601172	01S/03W-20C		2007	0	0	0	0	0	0	0	0
KANSAS STREET MUTUAL WATER COMPANY	W	3601092	01S/03W-28D01S	KANSAS		0	0	0	0	0	0	0	0
KING STREET MUTUAL WELL COMPANY	W	3600530	01S/02W-30G01S	1	1978	0	0	0	0	0	0	0	0
KING STREET MUTUAL WELL COMPANY	W	3600530-	01S/02W-30G02S	2		5	5	5	5	5	5	5	5
KING,	W	0000073	01N/04W-14R			1	1	1	1	1	1	1	1
KOCH,	W	0000074	01S/02W-32B		2005	0	0	0	0	0	0	0	0
KOCH, GEORGE J.	W	3601451	01S/02W-32G01S	1	1962	0	0	0	0	0	0	0	0
KRANTZ DAIRY	W	0000075	01S/04W-11F		2007	0	0	0	0	0	0	0	0
KUHN, RICHARD J.	W	0000178	01S/03W-32G			0	0	0	0	0	0	0	0
L P R ICE COMPANY WELL	W	3602525	01S/03W-13C	LPR ICE CO	1991	0	0	0	0	0	0	0	0
L. P. R. RANCH	W	0000080	01S/03W-13C		1972	0	0	0	0	0	0	0	0
LA BONTE, JIM	W	3600865	01N/04W-24H	MULTOWN2		4	4	4	4	4	4	4	4

**WESTERN - SAN BERNARDINO WATERMASTER
VERIFIED PRODUCTION DATA - NON PLAINTIFFS
CROSS INDEX BY OWNER
SAN BERNARDINO BASIN**

OWNER	WELL TYPE	RECRD TN NUMBER	STATE WELL NUMBER	LOCAL DESIGNATION	YEAR CLOSED	-----CALENDAR YEAR EXTRACTIONS-----										
						2008	2009	2010	2011	2012	AVG					
LA ROSSE, CHARLES H	W	3600708	01S/03W-29B	GOODWIN	1966	0	0	0	0	0	0	0	0	0	0	
LAKESIDE AVENUE MUTUAL WELL COMPANY	W	3602119	01S/03W-33C01S	REDLANDS	1974	0	0	0	0	0	0	0	0	0	0	
LANDMARK LAND COMPANY	W	3600187	01S/02W-09Q01S	1, SOLANO WELL #1	2000	0	0	0	0	0	0	0	0	0	0	
LANGSTON-NEWBY DEVELOPMENT COMPANY	W	3600218	01N/04W-24A	1	1980	0	0	0	0	0	0	0	0	0	0	
LOMA LINDA UNIVERSITY	W	3601910	01S/03W-30L	PUFFER	1975	0	0	0	0	0	0	0	0	0	0	
LOMA LINDA UNIVERSITY	W	3602008	01S/04W-26A	1	1980	0	0	0	0	0	0	0	0	0	0	
LOMA LINDA UNIVERSITY	W	3602009	01S/04W-25G01S	3	1964	0	0	0	0	0	0	0	0	0	0	
LOMA LINDA UNIVERSITY	W	3602012	01S/04W-25C01S	6	1984	0	0	0	0	0	0	0	0	0	0	
LOMA LINDA UNIVERSITY	W	3602013	01S/04W-24N	7	1967	0	0	0	0	0	0	0	0	0	0	
LOMA LINDA UNIVERSITY	W	3602014	01S/04W-26J01S	8	1974	0	0	0	0	0	0	0	0	0	0	
LOMA LINDA UNIVERSITY	W	3602017	01S/04W-25E01S	2	1964	0	0	0	0	0	0	0	0	0	0	
LOMA LINDA UNIVERSITY	W	3602249	01S/04W-25D05S	ANDERSON	1985	0	0	0	0	0	0	0	0	0	0	
LOMA LINDA UNIVERSITY	W	3602781	01S/04W-25D06S	ANDERSON II		92	89	138	67	64	90					
LOMA LINDA UNIVERSITY	W	3602855	01S/04W-25D07S	ANDERSON III		1,308	1,270	1,155	1,276	1,353	1,272					
LOMA LINDA, CITY OF	W	3601384	01S/04W-25C	1	1969	0	0	0	0	0	0	0	0	0	0	
LOMA LINDA, CITY OF	W	3601388	01S/04W-25C	COURT ST	1997	0	0	0	0	0	0	0	0	0	0	
LOMA LINDA, CITY OF	W	3601989	01S/04W-24R01S	GOLCONDA	1974	0	0	0	0	0	0	0	0	0	0	
LOMA LINDA, CITY OF	W	3602010	01S/04W-25H02S	VAN LEUVEN	1991	0	0	0	0	0	0	0	0	0	0	
LOMA LINDA, CITY OF	W	3602011	01S/04W-25B02S	DART	1990	0	0	0	0	0	0	0	0	0	0	
LOMA LINDA, CITY OF	W	3602015	01S/04W-25B	NIES	1992	0	0	0	0	0	0	0	0	0	0	
LOMA LINDA, CITY OF	W	3602016	01S/04W-25G	ROBINSON	1972	0	0	0	0	0	0	0	0	0	0	
LOMA LINDA, CITY OF	W	3602057	01S/04W-25C	MITTLEID	1979	0	0	0	0	0	0	0	0	0	0	
LOMA LINDA, CITY OF	W	3602058	01S/04W-25F	CROOKS	1991	0	0	0	0	0	0	0	0	0	0	
LOMA LINDA, CITY OF	W	3602596	01S/04W-24R07S	NEW GOLCONDA	1978	0	0	0	0	0	0	0	0	0	0	
LOMA LINDA, CITY OF	W	3602759	01S/04W-24A01S	MT VIEW 1	1999	0	0	0	0	0	0	0	0	0	0	
LOMA LINDA, CITY OF	W	3602760	01S/04W-24B01S	MT VIEW 2	2000	0	0	0	0	0	0	0	0	0	0	
LOMA LINDA, CITY OF	W	3603057	01S/04W-24C01S	RICHARDSON #1		422	323	56	0	0	160					
LOMA LINDA, CITY OF	W	3603058	01S/04W-24C02S	RICHARDSON #2	2001	0	0	0	0	0	0	0	0	0	0	
LOMA LINDA, CITY OF	W	3603523	01S/04W-24P04S	RICHARDSON #3		1,503	1,546	1,046	978	951	1,205					
LOMA LINDA, CITY OF	W	3603719	01S/04W-24A05S	MTN. VIEW #3		1,732	2,265	2,200	442	795	1,487					
LOMA LINDA, CITY OF	W	3603720	01S/04W-24F11S	RICHARDSON #4		464	446	51	0	0	192					
LOMA LINDA, CITY OF	W	3603721	01S/04W-24R08S	MTN. VIEW #4		0	0	0	0	0	0					
LOMA LINDA, CITY OF	W	3603776	01S/04W-24B03S	MTN. VIEW #5		592	44	138	0	0	155					
LOMA LINDA, CITY OF	W	3603927	01S/04W-24L07S	RICHARDSON #6		0	0	1,372	1,989	1,188	910					
LOMA LINDA, CITY OF	W	3603955	01S/04W-24B05S	RICHARDSON #5		0	0	0	1,252	1,305	511					
LOMA LINDA, CITY OF	W	3603956	01S/04W-24B04S	MTN. VIEW #6		0	0	0	740	1,537	455					
LULY, LUCIAN L	D	3601376	01N/04W-14C	WATERMAN	1960	0	0	0	0	0	0	0	0	0	0	

**WESTERN - SAN BERNARDINO WATERMASTER
VERIFIED PRODUCTION DATA - NON PLAINTIFFS
CROSS INDEX BY OWNER
SAN BERNARDINO BASIN**

OWNER	WELL TYPE	RECRD TN NUMBER	STATE WELL NUMBER	LOCAL DESIGNATION	YEAR CLOSED	-----CALENDAR YEAR EXTRACTIONS-----					AVG
						2008	2009	2010	2011	2012	
LULY, LUCIAN L	D	3601377	01N/04W-14C	WATERMAN	1960	0	0	0	0	0	0
LULY, LUCIAN L	D	3601378	01N/04W-14C	WATERMAN	1960	0	0	0	0	0	0
MAJESTIC MANAGEMENT	W	3601102	01S/03W-21E	2 / MASCART	2007	0	0	0	0	0	0
MARIGOLD FARMS COMPANY	W	3600757	01S/03W-19L	2, MISSION #2		250	250	250	289	225	253
MARIGOLD FARMS COMPANY	W	3601749	01S/03W-19B01S	JAP	1974	0	0	0	0	0	0
MARSHBURN,	W	0000081	01S/03W-17G			100	100	100	100	100	100
MAYBELL, N O	W	3600291	01S/04W-12N		1965	0	0	0	0	0	0
MCCALLA BROS.	W	0000164	01S/03W-20Q		1984	0	0	0	0	0	0
MCCALLA, ROBERT	W	3601839	01S/03W-10D01S	1	2007	0	0	0	0	0	0
MEADOWBROOK DAIRY	W	3600030	01S/04W-23D	IRRIIG 2	2004	0	0	0	0	0	0
MEADOWBROOK DAIRY	W	3600037	01S/04W-23D	DOMESTC 1	2004	0	0	0	0	0	0
MENTONE CITRUS GROWERS	W	3600139	01S/02W-18R01S	1-PRH RANCH		148	153	117	114	71	121
MENTONE CITRUS GROWERS	W	3602280	01S/02W-18Q	#2		518	587	531	802	871	662
MENTONE DOMESTIC WATER COMPANY	W	0000083	01S/02W-19J		1978	0	0	0	0	0	0
MENTONE DOMESTIC WATER COMPANY	W	0000176	01S/02W-19J	3 1971	1975	0	0	0	0	0	0
MEYER, CHARLES R	W	3600760	01N/05W-01R	1	1991	0	0	0	0	0	0
MILLER MUTUAL WELL COMPANY	W	3600630	01N/03W-32D		1961	0	0	0	0	0	0
MILLER MUTUAL WELL COMPANY	W	3600630-	01N/03W-32D			5	5	5	5	5	5
MONTE LLC	W	3600493	01S/03W-29K	2 NEW WELL	2006	0	0	0	0	0	0
MONTE LLC	W	3600494	01S/03W-29K	1 OLD WELL		65	59	53	63	65	61
MONTECITO MEMORIAL PARK	W	3600119	01S/04W-26F01S	1		270	270	223	130	155	210
MONTECITO MEMORIAL PARK	W	3603949	01S/04W-26F	MONTECITO #2		0	0	223	138	177	108
MOORE, R. H.	W	0000084	01S/04W-24K		2007	0	0	0	0	0	0
MOUNT VERNON WATER CO.	W	3600319	01N/04W-31A01S	1		927	1,132	167	685	799	742
MOUNTAIN VIEW POWER CO.	W	3600651	01S/03W-28L		1977	0	0	0	0	0	0
MOUNTAIN VIEW POWER CO.	W	3601012	01S/04W-08R	STM PL 1	1977	0	0	0	0	0	0
MOUNTAIN VIEW POWER CO.	W	3601013	01S/04W-08R	STM PL 2	1977	0	0	0	0	0	0
MOUNTAIN VIEW POWER CO.	W	3601014	01S/03W-18N03S	MTN. VIEW STPM 66		389	103	260	256	403	282
MOUNTAIN VIEW POWER CO.	W	3601015	01S/03W-18N02S	MT VIEW STMP2 #67		89	257	131	64	10	110
MOUNTAIN VIEW POWER CO.	W	3601016	01S/04W-22G01S	THORN 1	1977	0	0	0	0	0	0
MOUNTAIN VIEW POWER CO.	W	3603795	01S/03W-18N06S	MVL MID-AQUIFER #1		1,031	972	1,172	1,225	1,864	1,253
MOUNTAIN VIEW POWER CO.	W	3603796	01S/03W-18M01S	MVL MID-AQUIFER #2		1,073	935	838	449	356	730
MOUNTAIN VIEW POWER CO.	W	3604011	01S/03W-18N04S	AUX 2A	2005	0	0	0	0	0	0
MT. VIEW CEMETERY	W	3600742	01N/04W-26N	1	1978	0	0	0	0	0	0
MT. VIEW CEMETERY	W	3600742-	01N/04W-26N	MT VIEW #2 (#3 WEST)		104	109	123	151	114	120
MT. VIEW CEMETERY	W	3600743	01N/04W-26M	MT VIEW #1 (#2 SHED)		141	126	119	111	161	132
MT. VIEW CHILD CARE CENTER	W	0000145	01S/04W-24J		2007	0	0	0	0	0	0

**WESTERN - SAN BERNARDINO WATERMASTER
VERIFIED PRODUCTION DATA - NON PLAINTIFFS
CROSS INDEX BY OWNER
SAN BERNARDINO BASIN**

OWNER	WELL TYPE	RECRD TN NUMBER	STATE WELL NUMBER	LOCAL DESIGNATION	YEAR CLOSED	-----CALENDAR YEAR EXTRACTIIONS-----										
						2008	2009	2010	2011	2012	AVG					
MUSCOY MUTUAL WATER COMPANY NO. 1	W	3601497	01N/05W-23H01S	MUSCOY 1		460	1,203	379	318	375	547					
MUSCOY MUTUAL WATER COMPANY NO. 1	W	3601498	01N/05W-24D01S	LACY #5		375	317	450	308	308	352					
MUSCOY MUTUAL WATER COMPANY NO. 1	W	3601499	01N/05W-23A01S	MUSCOY 2		463	80	314	413	393	333					
MUSCOY MUTUAL WATER COMPANY NO. 1	W	3601500	01N/05W-23A02S	MUSCOY 3		463	87	322	416	453	348					
MUSCOY MUTUAL WATER COMPANY NO. 1	W	3602345	01N/05W-24E01S	MUSCOY 4		203	40	161	236	222	172					
NATIONAL ORANGE SHOW	W	3601924	01S/04W-15D			20	50	1	50	62	37					
NEALEY MUTUAL WATER COMPANY	D	3601381	01N/05W-07C		1958	0	0	0	0	0	0					
NEW ENGLAND WATER COMPANY	W	3602320-	01S/03W-16L			229	250	200	195	360	247					
NICKERSON WATER COMPANY	W	3600123	01S/03W-20R01S	1	1988	0	0	0	0	0	0					
NICKERSON WATER COMPANY NO 2	W	3600124	01S/03W-21M01S	2	1981	0	0	0	0	0	0					
NO NAME WELL	W	0000085	01N/03W-32M		2005	0	0	0	0	0	0					
NORTH FORK WATER COMPANY	W	3600678	01S/02W-08C01S	1	2001	0	0	0	0	0	0					
NORTH FORK WATER COMPANY	W	3600679	01S/02W-08C02S	N FORK #2	2001	0	0	0	0	0	0					
NORTH FORK WATER COMPANY	W	3601644	01S/03W-01A	PLUNGE CK	2000	0	0	0	0	0	0					
NORTHBRAE WATER COMPANY	W	3600296	01S/03W-15R01S	1	1974	0	0	0	0	0	0					
NORTHSIDE WATER COMPANY	W	3600933	01S/03W-23F	1	1978	0	0	0	0	0	0					
NORWOOD,	W	0000095	01N/03W-34F		2007	0	0	0	0	0	0					
PACIFIC HIGH SCHOOL	W	0000096	01N/04W-35H		1965	0	0	0	0	0	0					
PATTERSON, ROY H.	W	0000163	01N/03W-34Q		2007	0	0	0	0	0	0					
PAYNE, LARRY	W	3603698	02N/05W-27L	OWNERS #1		40	1	1	1	1	9					
PAYNE, LARRY	W	3603699	02N/05W-27L02S	OWNERS #2		0	1	1	1	1	1					
PAYNE, LARRY	W	3603700	02N/05W-27L03S	OWNERS #3		0	0	0	0	0	0					
PENN WELL COMPANY	W	3601099	01S/03W-22F	1	1957	0	0	0	0	0	0					
PENN WELL COMPANY	W	3601405	01S/03W-22F	2	1981	0	0	0	0	0	0					
PHARAOHS LOST KINDGOM	W	3602549	01S/03W-19J07S	CALIF ST		50	50	50	33	30	43					
PHAROAH-POWELL WATER CO	W	3600415	01S/03W-29J01S			199	241	182	169	218	202					
PIERSON,	W	0000097	01N/04W-35N		1999	0	0	0	0	0	0					
PIONEER MUTUAL WATER CO	W	3600642	01S/03W-14P01S	SBDNO 1		30	20	21	22	24	23					
QUALITY FARMS	W	0000053	01S/03W-04R	NO. 102	2007	0	0	0	0	0	0					
RAMIREZ, J. J.	W	3600484	01S/03W-16F	BUCKEYE2		0	0	0	0	0	0					
RAMIREZ, J. J.	W	3600525	01S/03W-17H01S	ALABAMA	2007	0	0	0	0	0	0					
RAMIREZ, J. J.	W	3600527	01S/03W-16A	MIDAS		125	119	98	96	95	107					
RAMIREZ, J. J.	W	3601046	01S/03W-21A	STOWE	1956	0	0	0	0	0	0					
RAMIREZ, J. J.	W	3601046-	01S/03W-21A	STOWE	2007	0	0	0	0	0	0					
RAMIREZ, J. J.	W	3601649-	01S/03W-28M	HOOVER		0	0	0	0	0	0					
RAMIREZ, J. J.	W	3601728	01S/03W-30K	FRINK'S #1		0	0	0	0	0	0					
RAMSEY,	D	0000098	01S/02W-22F	SPRING DIV	2007	0	0	0	0	0	0					

**WESTERN - SAN BERNARDINO WATERMASTER
VERIFIED PRODUCTION DATA - NON PLAINTIFFS
CROSS INDEX BY OWNER
SAN BERNARDINO BASIN**

OWNER	WELL TYPE	RECRDTN NUMBER	STATE WELL NUMBER	LOCAL DESIGNATION	YEAR CLOSED	-----CALENDAR YEAR EXTRACTIONS-----										
						2008	2009	2010	2011	2012	AVG					
RANCHO CITRUS AMIGOS	W	3601753	01S/03W-29D	PARK AVE 1	1971	0	0	0	0	0	0	0	0	0	0	
RAUGHT MUTUAL WELL COMPANY	W	3602193	01S/03W-14R01S	RAUGHT		204	248	215	239	255	232					
REDLANDS ASSOCIATES	W	0000099	01S/02W-17B	#0	2007	0	0	0	0	0	0	0	0	0	0	
REDLANDS ASSOCIATES	W	0000100	01S/02W-09P	BLOCK NO. 6	1972	0	0	0	0	0	0	0	0	0	0	
REDLANDS ASSOCIATES	W	0000101	01S/02W-09L	BLOCK NO. 11	1972	0	0	0	0	0	0	0	0	0	0	
REDLANDS ASSOCIATES	D	0000102	01S/02W-09L	TUNNEL DIV.	1980	0	0	0	0	0	0	0	0	0	0	
REDLANDS COUNTRY CLUB	W	3600049	01S/03W-25N01S	MORRISON	1978	0	0	0	0	0	0	0	0	0	0	
REDLANDS COUNTRY CLUB	W	3600049-	01S/03W-25N02S	MORRISON/HOBBS	2006	0	0	0	0	0	0	0	0	0	0	
REDLANDS FARMING	W	3600523	01S/03W-32G03S	HNTSCHKE	1980	0	0	0	0	0	0	0	0	0	0	
REDLANDS FARMING	W	3600526	01S/03W-21G01S	LUGONIA	1981	0	0	0	0	0	0	0	0	0	0	
REDLANDS TRAP/SKEET	W	3600628	01S/03W-15G		1980	0	0	0	0	0	0	0	0	0	0	
REDLANDS UNIFIED SCHOOL DISTRICT	W	3601641	01S/02W-30C01S	OPAL ST		140	201	98	59	109	121					
REDLANDS WATER COMPANY	D	0000104	01S/02W-08A	REDLANDS WATER COM		625	654	629	739	529	635					
REDLANDS, CITY OF	D	0000103	01S/02W-13B	MILL CREEK DIV	1980	0	0	0	0	0	0	0	0	0	0	
REDLANDS, CITY OF	W	3600005	01S/03W-35H08S	LUETCKE	1981	0	0	0	0	0	0	0	0	0	0	
REDLANDS, CITY OF	W	3600006	01S/02W-19G01S	E. LUGONIA #5		0	0	0	0	0	0	0	0	0	0	
REDLANDS, CITY OF	W	3600019	01S/03W-23A05S	GR REES 1		0	258	1,114	1,759	1,633	953					
REDLANDS, CITY OF	D	3600038	01S/02W-17N	DRY CREEK DIVERSION	1974	0	0	0	0	0	0	0	0	0	0	
REDLANDS, CITY OF	W	3600053	01S/03W-31A02S	1, BRYN MAWR		0	0	0	0	0	0	0	0	0	0	
REDLANDS, CITY OF	W	3600054	01S/03W-31A03S	2, BRYN MAWR MUTUAL	1964	0	0	0	0	0	0	0	0	0	0	
REDLANDS, CITY OF	W	3600055	01S/03W-31A06S	3, BRYN MAWR MUTUAL	1975	0	0	0	0	0	0	0	0	0	0	
REDLANDS, CITY OF	W	3600085	01S/03W-28J01S	NY ST 1	1966	0	0	0	0	0	0	0	0	0	0	
REDLANDS, CITY OF	W	3600510	01S/03W-21K01S	LUGO #1	2003	0	0	0	0	0	0	0	0	0	0	
REDLANDS, CITY OF	W	3600748	01S/03W-24A01S	MENTONE ACRES #1-OL		0	973	91	73	75	242					
REDLANDS, CITY OF	W	3600749	01S/03W-13P01S	MENTONE ACRES #2-NE		813	0	155	1,743	1,357	814					
REDLANDS, CITY OF	W	3600756	01S/03W-19L01S	MISSION #1		0	0	0	0	0	0					
REDLANDS, CITY OF	W	3600918	02S/03W-01D01S	1, REDLANDS HEIGHTS		364	373	321	381	401	368					
REDLANDS, CITY OF	W	3601281	01S/02W-21M01S	MAGUET #1		0	0	0	0	0	0					
REDLANDS, CITY OF	W	3601282	01S/01W-08H01S	MILL CREEK #1		0	0	0	0	0	0					
REDLANDS, CITY OF	W	3601283	01S/02W-22C02S	EAST LUGONIA #2		0	0	0	0	0	0					
REDLANDS, CITY OF	W	3601284	01S/02W-21E01S	MAGUET #2		0	0	0	0	0	24					
REDLANDS, CITY OF	W	3601285	01S/01W-10L01S	MILL CREEK #2		2,096	1,399	2,537	2,403	2,349	2,157					
REDLANDS, CITY OF	W	3601286	01S/02W-21E02S	MAGUET #3	1981	0	0	0	0	0	0					
REDLANDS, CITY OF	W	3601287	01S/02W-21B02S	EAST LUGONIA #3		8	83	167	52	18	66					
REDLANDS, CITY OF	W	3601288	01S/01W-11Q01S	MILL CREEK #4		775	816	128	0	387	421					
REDLANDS, CITY OF	W	3601289	01S/03W-35E	4R	1979	0	0	0	0	0	0					
REDLANDS, CITY OF	W	3601290	01S/02W-21D01S	EAST LUGONIA #6		0	33	16	0	0	10					

**WESTERN - SAN BERNARDINO WATERMASTER
VERIFIED PRODUCTION DATA - NON PLAINTIFFS
CROSS INDEX BY OWNER
SAN BERNARDINO BASIN**

OWNER	WELL TYPE	RECRD TN NUMBER	STATE WELL NUMBER	LOCAL DESIGNATION	YEAR CLOSED	-----CALENDAR YEAR EXTRACTIIONS-----										
						2008	2009	2010	2011	2012	AVG					
REDLANDS, CITY OF	W	3601291	01S/03W-35G08S	10		0	0	0	0	0	0	0	0	0	0	
REDLANDS, CITY OF	W	3601292	01S/03W-35G07S	11		69	75	94	108	136	96					
REDLANDS, CITY OF	W	3601293	01S/03W-35H02S	12	2006	0	0	0	0	0	0	0	0	0	0	
REDLANDS, CITY OF	W	3601294	01S/03W-35G09S	13		0	0	0	0	0	0	0	0	0	0	
REDLANDS, CITY OF	W	3601295	01S/03W-35H04S	14		0	0	0	0	0	0	0	0	0	0	
REDLANDS, CITY OF	W	3601296	01S/03W-35H03S	16		694	1,141	473	22	0	466					
REDLANDS, CITY OF	W	3601297	01S/03W-35G11S	17	2010	0	0	0	0	0	0	0	0	0	0	
REDLANDS, CITY OF	W	3601298	01S/03W-21H01S	32		0	0	0	0	0	0	0	0	0	0	
REDLANDS, CITY OF	W	3601299	01S/04W-24K01S	34		0	0	0	0	0	0	0	0	0	0	
REDLANDS, CITY OF	W	3601300	01S/03W-27E02S	40	1988	0	0	0	0	0	0	0	0	0	0	
REDLANDS, CITY OF	W	3601301	01S/03W-28H01S	41		465	448	404	443	366	425					
REDLANDS, CITY OF	D	3601302	01S/02W-14H	COOLIE HAT - MILL CK		12,332	7,785	10,076	13,492	10,679	10,873					
REDLANDS, CITY OF	W	3601308	01S/02W-19K01S	AGATE 1		0	0	50	139	0	38					
REDLANDS, CITY OF	W	3601586	01S/03W-15F01S	ORANGE STREET		567	694	1,065	1,406	1,600	1,066					
REDLANDS, CITY OF	W	3601636	01S/04W-24R	LANGFORD	1973	0	0	0	0	0	0	0	0	0	0	
REDLANDS, CITY OF	W	3601637	01S/03W-30D	LANGFORD	1977	0	0	0	0	0	0	0	0	0	0	
REDLANDS, CITY OF	W	3602031	01S/03W-21H06S	30-A		207	257	360	616	304	349					
REDLANDS, CITY OF	W	3602032	01S/03W-22A02S	35		0	0	0	0	0	0	0	0	0	0	
REDLANDS, CITY OF	W	3602036	01S/03W-21H07S	31-A		0	0	0	0	0	106	21				
REDLANDS, CITY OF	W	3602065	01S/03W-32J02S	LEE WELL	1978	0	0	0	0	0	0	0	0	0	0	
REDLANDS, CITY OF	W	3602065-	01S/03W-32J02S	LEE WELL		0	0	0	0	0	0	0	0	0	0	
REDLANDS, CITY OF	W	3602082	02S/03W-03K01S	36 (CEMETERY)		216	189	180	181	177	189					
REDLANDS, CITY OF	W	3602106	01S/03W-22A01S		1968	0	0	0	0	0	0	0	0	0	0	
REDLANDS, CITY OF	W	3602109	01S/03W-31B01S	4, BRYN MAWR		0	0	0	0	0	0	0	0	0	0	
REDLANDS, CITY OF	W	3602211	01S/03W-26C01S	37 SYLVAN PARK		0	0	0	0	0	0	0	0	0	0	
REDLANDS, CITY OF	W	3602346	01S/03W-28K01S	NEW YORK ST. WELL		1,217	1,009	1,000	945	843	1,003					
REDLANDS, CITY OF	W	3602351	01S/02W-13A01S	MILL CREEK 0-A		1	0	0	0	0	0	0	0	0	0	
REDLANDS, CITY OF	W	3602653	01S/02W-19J01S	2	1979	0	0	0	0	0	0	0	0	0	0	
REDLANDS, CITY OF	W	3602654	01S/02W-19J02S	CRAFTON		421	514	342	144	392	363					
REDLANDS, CITY OF	W	3602791	01S/02W-20B01S	EAST LUGONIA #4		0	0	88	0	0	18					
REDLANDS, CITY OF	W	3602792	01S/02W-19A01S	AGATE #2		1,551	1,910	1,199	83	278	1,004					
REDLANDS, CITY OF	W	3602895	01S/03W-13H02S	AIRPORT #1		1,369	1,285	1,426	1,367	1,695	1,428					
REDLANDS, CITY OF	W	3602896	01S/02W-20D01S	MADEIRA		667	626	555	555	32	487					
REDLANDS, CITY OF	W	3603045	01S/01W-09J01S	MILL CK #2A		0	256	9	0	0	53					
REDLANDS, CITY OF	W	3603655	01S/03W-29Q01S	#38		1,701	1,646	1,897	2,037	1,809	1,818					
REDLANDS, CITY OF	W	3603656	01S/03W-14E01S	CHURCH STREET		172	253	204	679	1,115	485					
REDLANDS, CITY OF	W	3603760	01S/03W-29Q02S	WELL 39		302	1,086	935	999	1,082	881					

**WESTERN - SAN BERNARDINO WATERMASTER
VERIFIED PRODUCTION DATA - NON PLAINTIFFS
CROSS INDEX BY OWNER
SAN BERNARDINO BASIN**

OWNER	WELL TYPE	RECRD TN NUMBER	STATE WELL NUMBER	LOCAL DESIGNATION	YEAR CLOSED	-----CALENDAR YEAR EXTRACTIONS-----										
						2008	2009	2010	2011	2012	AVG					
REDLANDS, CITY OF	W	3603761	01S/03W-18R	CALIF.ST. IRRIGATION		588	654	501	509	627	576					
REDLANDS, CITY OF	W	3603762	01S/03W-13M	AIRPORT 2		754	888	346	102	248	468					
REDLANDS, CITY OF	W	3603766	01S/03W-10K01S	NORTH ORANGE #1		2,232	1,823	1,208	614	2,043	1,584					
REDLANDS, CITY OF	W	3603767	01S/03W-10K02S	NORTH ORANGE #2		2,741	1,760	1,987	1,024	2,087	1,920					
REDLANDS, CITY OF	W	3603943	01S/03W-15N	WEATHERWAX #2		32	33	32	32	55	37					
REES & PERRICONE RANCH	W	3602171	01S/02W-18M	1	1981	0	0	0	0	0	0					
REES-REES RANCHES INC	W	3600018	01S/02W-29P	GRREES 2		0	0	0	0	0	0					
REGINA GRAPE PRODUCTS	W	0000105	01N/05W-04M	WELL NO. 1	1985	0	0	0	0	0	0					
REGINA GRAPE PRODUCTS	W	0000106	01N/05W-04N	WELL NO. 2	1985	0	0	0	0	0	0					
REGINA GRAPE PRODUCTS	W	0000107	01N/05W-04N	WELL NO. 3	1985	0	0	0	0	0	0					
REGINA GRAPE PRODUCTS	D	0000108	01N/05W-05C	SPRING DIV.	1985	0	0	0	0	0	0					
REGINA GRAPE PRODUCTS	W	0000109	01N/05W-05R	WELL NO. 4	1985	0	0	0	0	0	0					
REGINA GRAPE PRODUCTS	W	0000110	01N/05W-04N	WELL NO. 5	1985	0	0	0	0	0	0					
REGINA GRAPE PRODUCTS	W	0000111	01N/05W-04N	WELL NO. 6	1985	0	0	0	0	0	0					
REGINA GRAPE PRODUCTS	W	0000112	01N/05W-04N	WELL NO. 7	1985	0	0	0	0	0	0					
REYNOLDS, BILL	W	3600981	01S/02W-21H01S		1957	0	0	0	0	0	0					
RIALTO, CITY OF	W	3601085	01N/04W-31N02S	CITY 4 / #1	1992	0	0	0	0	0	0					
RIALTO, CITY OF	W	3601263	01N/05W-23Q01S	CITY #1		241	1	0	0	0	48					
RIALTO, CITY OF	D	3601718	01N/05W-22M	FILTER		1,165	1,123	1,210	1,171	1,311	1,196					
RIALTO, CITY OF	W	3601929	01S/04W-06C04S	CITY #6		0	0	0	0	0	0					
RIALTO, CITY OF	W	3602080	01N/05W-23Q02S	CITY #2		2,565	1,961	2,102	1,336	842	1,761					
RIALTO, CITY OF	W	3602848	01N/05W-36B01S	CITY #3		147	23	33	0	24	45					
RIALTO, CITY OF	W	3603030	01S/04W-06B01S	CITY #5		0	0	0	0	0	0					
RIALTO, CITY OF	W	3603538	01S/04W-06H04S	CITY #4A		2,427	2,605	1,980	870	932	1,763					
RIEDMAN, FRED M	W	3601629	01S/03W-03P	1	1961	0	0	0	0	0	0					
RIVAS, RAMON	W	0000113	01S/04W-24J	REES 4	1987	0	0	0	0	0	0					
RIVENDELL LAND COMPANY	W	36001751	01S/03W-21E	ALABAMA/CHRISTINA	1981	0	0	0	0	0	0					
ROBBINS, H W	W	3602170	01S/02W-31M			5	5	5	5	5	5					
RULE,	W	0000114	01N/03W-34K	SPRING	1974	0	0	0	0	0	0					
SAN BERNARDINO AVE WATER CO.	W	3600125	01S/03W-14P	1		0	0	0	0	0	0					
SAN BERNARDINO COUNTY - FACILITY MANAGE	W	0000001	01S/04W-14A	AEROSPACE	2005	0	0	0	0	0	0					
SAN BERNARDINO COUNTY - FACILITY MANAGE	W	3600468	01S/03W-30Q	BAHR 1	1971	0	0	0	0	0	0					
SAN BERNARDINO COUNTY - FACILITY MANAGE	W	3601171	01S/03W-20F	1/CRIM	2007	0	0	0	0	0	0					
SAN BERNARDINO COUNTY - FACILITY MANAGE	W	3603932	01N/04W-35L06S	COUNTY HOSP-GIBERT		118	0	4	0	0	0				24	
SAN BERNARDINO COUNTY - FACILITY MANAGE	W	3603934	02N/05W-33F	GLEN HELEN 3		265	808	206	34	193	301					
SAN BERNARDINO COUNTY - FACILITY MANAGE	W	3603935	02N/05W-33G01S	GLEN HELEN 4		16	18	274	362	111	156					

**WESTERN - SAN BERNARDINO WATERMASTER
VERIFIED PRODUCTION DATA - NON PLAINTIFFS
CROSS INDEX BY OWNER
SAN BERNARDINO BASIN**

OWNER	WELL TYPE	RECRD TN NUMBER	STATE WELL NUMBER	LOCAL DESIGNATION	YEAR CLOSED	-----CALENDAR YEAR EXTRACTIONS-----										
						2008	2009	2010	2011	2012	AVG					
SAN BERNARDINO COUNTY - FACILITY MANAGE	W	3603936	02N/05W-33D01S	GLEN HELEN #5		2	0	290	314	115	144					
SAN BERNARDINO COUNTY - FACILITY MANAGE	W	3603937	02N/05W-33G02S	GLEN HELEN #6		626	354	266	148	447	368					
SAN BERNARDINO COUNTY - REGIONAL PARKS	W	3603933	01N/05W-04B	GLEN HELEN 1A (2)		34	40	39	4	39	31					
SAN BERNARDINO COUNTY FLOOD CONTROL	W	3601130	01S/03W-32D	NICK'S WELL		149	190	189	0	0	106					
SAN BERNARDINO COUNTY FLOOD CONTROL	W	3603900	01S/02W-04N	DOMESTIC WELL NO. 3		4	4	4	10	4	5					
SAN BERNARDINO VALLEY M.W.D.	W	3603116	01S/03W-13Q01S	SB AVE #1/BIG BEAR		761	462	291	618	875	601					
SAN BERNARDINO VALLEY M.W.D.	W	3603141	01S/04W-04E01S	9TH ST.	2011	0	0	0	0	0	0					
SAN BERNARDINO VALLEY M.W.D.	W	3603174	01S/04W-04F02S	PERRIS ST		0	0	0	0	0	0					
SAN BERNARDINO VALLEY M.W.D.	W	3603944	01S/04W-22C06S	DE-WATERING #1		0	290	0	0	0	58					
SAN BERNARDINO VALLEY M.W.D.	W	3603945	01S/04W-22F01S	DE-WATERING #2		0	0	0	0	0	0					
SAN BERNARDINO VALLEY M.W.D.	W	3603964	01S/04W-05F02S	9TH STREET NORTH		0	0	0	0	0	0					
SAN BERNARDINO VALLEY M.W.D.	W	3603965	01S/04W-05F01S	9TH STREET SOUTH		0	0	0	0	0	0					
SAN BERNARDINO, CITY OF	W	0000115	01S/04W-21A	SEWER PLANT 1	2006	0	0	0	0	0	0					
SAN BERNARDINO, CITY OF	W	0000116	01S/04W-22C	SEWER PLANT 2	2005	0	0	0	0	0	0					
SAN BERNARDINO, CITY OF	W	3600034	01S/04W-16H	SMITH 1	1979	0	0	0	0	0	0					
SAN BERNARDINO, CITY OF	W	3600035	01S/04W-15M01S		1979	0	0	0	0	0	0					
SAN BERNARDINO, CITY OF	W	3600222	01S/04W-11Q01S	MCFARLAND JOHNSON	2000	0	0	0	0	0	0					
SAN BERNARDINO, CITY OF	D	3600320	01N/05W-22M	MT VERNON		0	0	0	0	0	0					
SAN BERNARDINO, CITY OF	W	3600709	02N/05W-19Q01S	VINCENT	1970	0	0	0	0	0	0					
SAN BERNARDINO, CITY OF	W	3600710	02N/05W-19K01S	CAJON CYN		495	255	375	447	220	358					
SAN BERNARDINO, CITY OF	W	3600711	01N/04W-07F01S	DEVIL CANYON #2		1,040	964	1,525	1,318	665	1,102					
SAN BERNARDINO, CITY OF	W	3600712	01N/04W-08M01S	DEVIL CANYON #1		659	1,192	1,053	1,070	892	973					
SAN BERNARDINO, CITY OF	W	3600713	01N/05W-36R01S	LYTLE CREEK # 3-1		0	0	0	0	0	0					
SAN BERNARDINO, CITY OF	W	3600714	01N/04W-16E01S	NEWMARK #1		495	223	132	257	253	272					
SAN BERNARDINO, CITY OF	W	3600715	01N/04W-16E02S	NEWMARK #2		808	415	188	383	741	507					
SAN BERNARDINO, CITY OF	W	3600716	01N/04W-16E03S	NEWMARK #3		1,588	1,312	1,154	1,545	1,504	1,421					
SAN BERNARDINO, CITY OF	W	3600717	01N/04W-32D03S	19TH ST #1		348	0	0	0	0	70					
SAN BERNARDINO, CITY OF	W	3600718	01N/04W-32D04S	19TH ST #2		289	1,171	1,085	786	617	790					
SAN BERNARDINO, CITY OF	W	3600719	01N/04W-27G01S	30TH ST.		1,810	1,478	1,176	272	136	974					
SAN BERNARDINO, CITY OF	W	3600720	01N/04W-27M02S	27TH ST. & ACACIA		512	261	152	229	435	318					
SAN BERNARDINO, CITY OF	W	3600721	01N/04W-27M01S	25TH & N. "E" ST.		0	0	0	0	0	0					
SAN BERNARDINO, CITY OF	W	3600722	01S/04W-03D01S	11TH & E ST. (ACACIA)	1968	0	0	0	0	0	0					
SAN BERNARDINO, CITY OF	W	3600723	01S/04W-10F01S	HANFORD 1	1968	0	0	0	0	0	0					
SAN BERNARDINO, CITY OF	W	3600724	01S/04W-10F05S	HANFORD 2	1968	0	0	0	0	0	0					
SAN BERNARDINO, CITY OF	W	3600725	01N/04W-34G01S	17 ST/SIERRA WAY #1		0	0	0	0	0	0					
SAN BERNARDINO, CITY OF	W	3600726	01N/04W-34G03S	16TH ST & SIERRA WAY		1,554	2,382	2,002	2,162	2,487	2,117					
SAN BERNARDINO, CITY OF	W	3600727	01N/04W-26E02S	LYNWOOD		1,460	1,071	1,049	302	244	825					

**WESTERN - SAN BERNARDINO WATERMASTER
VERIFIED PRODUCTION DATA - NON PLAINTIFFS
CROSS INDEX BY OWNER
SAN BERNARDINO BASIN**

OWNER	WELL TYPE	RECRD TN NUMBER	STATE WELL NUMBER	LOCAL DESIGNATION	YEAR CLOSED	-----CALENDAR YEAR EXTRACTIONS-----										
						2008	2009	2010	2011	2012	AVG					
SAN BERNARDINO, CITY OF	W	3600728	01N/04W-27A01S	WATERMAN AVE.		1,293	1,163	1,247	1,563	1,570	1,367					
SAN BERNARDINO, CITY OF	W	3600729	01N/04W-35M03S	GILBERT ST.		1,012	78	88	36	222	287					
SAN BERNARDINO, CITY OF	W	3600730	01S/04W-02K01S	ANTIL #3	1981	0	0	0	0	0	0					
SAN BERNARDINO, CITY OF	W	3600731	01S/04W-02K02S	ANTIL #5		0	0	0	0	0	0					
SAN BERNARDINO, CITY OF	W	3600732	01S/04W-02K05S	ANTIL #2	1978	0	0	0	0	0	0					
SAN BERNARDINO, CITY OF	W	3600733	01S/04W-02K04S	ANTIL #1	1981	0	0	0	0	0	0					
SAN BERNARDINO, CITY OF	W	3600734	01S/04W-02K03S	ANTIL #4		0	0	0	0	0	0					
SAN BERNARDINO, CITY OF	W	3600735	01S/04W-09P01S	BIRCH ST.	1981	0	0	0	0	0	0					
SAN BERNARDINO, CITY OF	W	3600736	01S/04W-09J01S	SOUTH G ST	1978	0	0	0	0	0	0					
SAN BERNARDINO, CITY OF	W	3600737	01S/04W-10N06S	MILL & D		429	377	397	502	398	421					
SAN BERNARDINO, CITY OF	D	3600738	01N/04W-06J	DEVIL CYN DIVERSION		0	0	0	0	0	0					
SAN BERNARDINO, CITY OF	D	3600739	01N/05W-06E	LYTLE CK DIV.		0	0	0	0	0	0					
SAN BERNARDINO, CITY OF	W	3601114	01N/04W-35C01S	PERRIS HILL 2	1981	0	0	0	0	0	0					
SAN BERNARDINO, CITY OF	W	3601115	01N/04W-26P03S	PERRIS HILL 5		1	1	1	0	0	0					
SAN BERNARDINO, CITY OF	W	3601116	01N/04W-35C02S	PERRIS HILL 3	2007	0	0	0	0	0	0					
SAN BERNARDINO, CITY OF	W	3601117	01N/04W-35C03S	PERRIS HILL 4		0	1	1	0	1	1					
SAN BERNARDINO, CITY OF	W	3601316	01S/04W-23N	INTERCITY MUTUAL 08		0	0	0	0	0	0					
SAN BERNARDINO, CITY OF	W	3601588	01N/04W-31H	STATE 1		0	0	0	0	0	0					
SAN BERNARDINO, CITY OF	W	3601626	01S/04W-10D	CITYLOTS	1969	0	0	0	0	0	0					
SAN BERNARDINO, CITY OF	W	3601843	01N/05W-03H01S	CAJON NO 1		0	0	0	0	0	0					
SAN BERNARDINO, CITY OF	W	3601844	01N/05W-03H02S	CAJON NO 2		1,094	1,160	1,366	1,673	1,443	1,347					
SAN BERNARDINO, CITY OF	W	3601845	01N/04W-30M01S	MALLORY NO. 3		337	593	356	903	667	571					
SAN BERNARDINO, CITY OF	W	3601878	01N/04W-29E01S	DARBY		0	0	0	0	0	0					
SAN BERNARDINO, CITY OF	W	3601879	01N/04W-29E	GARDENA		0	0	0	0	0	0					
SAN BERNARDINO, CITY OF	W	3601880	01N/04W-29F01S	COLIMA	2007	0	0	0	0	0	0					
SAN BERNARDINO, CITY OF	W	3602060	01S/04W-24P	JOHANSSON, RUNE	1974	0	0	0	0	0	0					
SAN BERNARDINO, CITY OF	W	3602066	01S/04W-02B	1, VAN LOON/BELVAN		0	0	0	0	0	0					
SAN BERNARDINO, CITY OF	W	3602067	01N/04W-35K	2-GILBERT/CANYON RD		0	0	0	0	0	0					
SAN BERNARDINO, CITY OF	W	3602081	01N/04W-27B01S	31ST ST. & MT VIEW		298	361	141	240	205	249					
SAN BERNARDINO, CITY OF	W	3602122	01S/04W-23R03S	ROSEWOOD	1966	0	0	0	0	0	0					
SAN BERNARDINO, CITY OF	W	3602123	01S/04W-14J	NORMAN RD		0	0	0	0	0	0					
SAN BERNARDINO, CITY OF	W	3602124	01S/04W-14J	CENTRAL AVE	1984	0	0	0	0	0	0					
SAN BERNARDINO, CITY OF	W	3602125	01S/04W-24F04S	GOULD #1 OLD	2007	0	0	0	0	0	0					
SAN BERNARDINO, CITY OF	W	3602126	01S/04W-24F	GOULD #2 NEW	2007	0	0	0	0	0	0					
SAN BERNARDINO, CITY OF	W	3602128	01S/04W-14A	GIFFORD PK/ #1	2007	0	0	0	0	0	0					
SAN BERNARDINO, CITY OF	W	3602205	01N/04W-06H01S	DEVIL CANYON #4		28	13	4	5	3	11					
SAN BERNARDINO, CITY OF	W	3602206	01N/04W-06H02S	DEVIL CANYON #3		141	56	9	0	1	41					

**WESTERN - SAN BERNARDINO WATERMASTER
VERIFIED PRODUCTION DATA - NON PLAINTIFFS
CROSS INDEX BY OWNER
SAN BERNARDINO BASIN**

OWNER	WELL TYPE	RECRD TN NUMBER	STATE WELL NUMBER	LOCAL DESIGNATION	YEAR CLOSED	-----CALENDAR YEAR EXTRACTIONS-----										
						2008	2009	2010	2011	2012	AVG					
SAN BERNARDINO, CITY OF	W	3602252	01S/04W-14B03S	2	1977	0	0	0	0	0	0	0	0	0	0	
SAN BERNARDINO, CITY OF	W	3602264	01N/04W-27N01S	23RD ST.	2010	0	0	0	0	0	0	0	0	0	0	
SAN BERNARDINO, CITY OF	W	3602265	01S/04W-03J05S	7TH ST.		140	226	79	165	165	216	165				
SAN BERNARDINO, CITY OF	W	3602285	01S/04W-15D05S	15D5	1979	0	0	0	0	0	0	0	0	0	0	
SAN BERNARDINO, CITY OF	W	3602399	01N/04W-16E04S	NEWMARK #4		1,554	366	901	1,527	1,573	1,573	1,184				
SAN BERNARDINO, CITY OF	W	3602400	01N/04W-32N01S	BASELINE & CALIFORNI		339	347	160	172	172	102	224				
SAN BERNARDINO, CITY OF	W	3602401	01N/04W-27A02S	LEROY		822	883	335	579	612	612	646				
SAN BERNARDINO, CITY OF	W	3602422	01S/04W-02K08S	ANTIL 6		0	81	5	27	0	0	23				
SAN BERNARDINO, CITY OF	D	3602426	02N/05W-19Q01S	VINCENT (CAJON CRK)		498	403	521	724	546	546	538				
SAN BERNARDINO, CITY OF	W	3602521	01S/04W-23N04S	NO 2	1977	0	0	0	0	0	0	0	0	0	0	
SAN BERNARDINO, CITY OF	W	3602821	01N/05W-03A02S	CAJON #3		954	823	578	696	946	946	799				
SAN BERNARDINO, CITY OF	W	3602844	01N/04W-08M02S	DEVIL CANYON #5		272	458	282	148	210	210	274				
SAN BERNARDINO, CITY OF	W	3603027	01N/05W-36J01S	LYTLE CK #2		652	659	500	737	622	622	634				
SAN BERNARDINO, CITY OF	W	3603206	01S/04W-04D02S	OLIVE/GARNER		1,306	1,194	1,225	1,739	1,113	1,113	1,315				
SAN BERNARDINO, CITY OF	W	3603207	01S/04W-04B04S	10TH & J ST		1,620	2,075	1,797	2,507	1,723	1,723	1,944				
SAN BERNARDINO, CITY OF	W	3603208	01N/04W-34G04	17TH ST. & SIERRA #2		282	76	279	17	16	16	134				
SAN BERNARDINO, CITY OF	W	3603471	02N/05W-19R04S	KENWOOD #1		1,166	1,132	1,423	1,770	1,400	1,400	1,378				
SAN BERNARDINO, CITY OF	W	3603472	01N/04W-14P03S	40TH & VALENCIA		67	21	217	141	181	181	125				
SAN BERNARDINO, CITY OF	W	3603579	01N/04W-06A02S	DEVIL CYN #7		92	66	67	77	81	81	77				
SAN BERNARDINO, CITY OF	W	3603580	01N/04W-06A01S	DEVIL CYN #6		194	182	176	201	196	196	190				
SAN BERNARDINO, CITY OF	W	3603581	01S/04W-22C05S	CENTURY		950	830	895	541	355	355	714				
SAN BERNARDINO, CITY OF	W	3603582	01S/04W-15P05S	CHANDLER		800	857	633	754	1,133	1,133	835				
SAN BERNARDINO, CITY OF	W	3603649	01S/03W-07A06S	IVDA 11 (NORTON #11)		70	101	61	59	84	84	75				
SAN BERNARDINO, CITY OF	W	3603688	01S/04W-03D04S	EPA #1		1,986	1,526	2,003	2,328	2,269	2,269	2,022				
SAN BERNARDINO, CITY OF	W	3603689	01S/04W-03C03S	EPA #2		2,165	2,260	2,243	2,337	2,680	2,680	2,337				
SAN BERNARDINO, CITY OF	W	3603690	01S/04W-03C04S	EPA #3		3,412	3,198	3,069	3,112	2,563	2,563	3,071				
SAN BERNARDINO, CITY OF	W	3603691	01S/04W-03B03S	EPA #4		2,107	2,201	1,918	2,011	1,874	1,874	2,022				
SAN BERNARDINO, CITY OF	W	3603692	01S/04W-03A04S	EPA #5		2,379	2,430	1,227	204	1,083	1,083	1,465				
SAN BERNARDINO, CITY OF	W	3603693	01N/04W-16M03S	EPA #6		529	593	438	513	551	551	525				
SAN BERNARDINO, CITY OF	W	3603694	01N/04W-16M04S	EPA #7		2,074	2,130	1,917	884	1,799	1,799	1,761				
SAN BERNARDINO, CITY OF	W	3603786	01N/04W-33R	EPA 108		2,362	2,399	1,882	2,070	2,256	2,256	2,194				
SAN BERNARDINO, CITY OF	W	3603787	01N/04W-33P	EPA 109		1,997	1,751	1,431	1,402	1,430	1,430	1,602				
SAN BERNARDINO, CITY OF	W	3603788	01N/04W-33N	EPA 110		2,493	2,253	1,683	1,464	1,649	1,649	1,908				
SAN BERNARDINO, CITY OF	W	3603789	01N/04W-32R	EPA 111		2,284	2,129	2,497	2,469	2,206	2,206	2,317				
SAN BERNARDINO, CITY OF	W	3603790	01N/04W32Q	EPA 112		2,472	2,177	1,698	1,329	1,665	1,665	1,868				
SAN BERNARDINO, CITY OF	W	3603791	02N/05W-19R05S	KENWOOD 2		1,850	1,419	1,369	1,608	1,362	1,362	1,522				
SAN BERNARDINO, CITY OF	W	3603792	01N/05W-03A03S	CAJON 4		1,558	1,348	1,283	1,397	2,285	2,285	1,574				

**WESTERN - SAN BERNARDINO WATERMASTER
VERIFIED PRODUCTION DATA - NON PLAINTIFFS
CROSS INDEX BY OWNER
SAN BERNARDINO BASIN**

OWNER	WELL TYPE	RECRDTN NUMBER	STATE WELL NUMBER	LOCAL DESIGNATION	YEAR CLOSED	-----CALENDAR YEAR EXTRACTATIONS-----										
						2008	2009	2010	2011	2012	AVG					
SAN BERNARDINO, CITY OF	W	3603917	01N/04W-33R03S	EPA 108S		924	925	891	929	765	887					
SAN BERNARDINO, CITY OF	W	3603960	01S/04W-15P06S	ORANGE SHOW RD/PRO		255	20	1	0	0	55					
SAN BERNARDINO, CITY OF	W	3690927	01N/03W-31B01S	PATTON 6	1984	0	0	0	0	0	0					
SAN MANUEL INDIAN RESERVATION	W	0000119	01N/03W-20N			0	0	0	0	0	0					
SAN MANUEL INDIAN RESERVATION	W	0000160	01N/03W-19R	DOMESTIC		1	1	1	1	1	1					
SAN MANUEL INDIAN RESERVATION	W	0000161	01N/03W-19R			15	15	15	15	15	15					
SAN MANUEL INDIAN RESERVATION	D	0000162	01N/03W-19R	YORK TUNNEL		0	0	0	0	0	0					
SANDY'S RESTAURANT	W	0000165	01S/03W-21M02S		2005	0	0	0	0	0	0					
SANTINI,	W	0000120	01S/04W-14A		2007	0	0	0	0	0	0					
SATOSKI,	W	0000121	01N/04W-14J			1	1	1	1	1	1					
SECHREST, RALPH F.	W	3600483	01S/02W-31F	GPHRRCH1	1980	0	0	0	0	0	0					
SELBY DR & MRS	W	3600017	01S/02W-29P	GRREES 3		0	0	0	0	0	0					
SELEY,	D	0000122	01N/03W-19Q	TUNNEL DIV.	2007	0	0	0	0	0	0					
SIX HOUSES	W	0000123	01S/04W-22A		1985	0	0	0	0	0	0					
SMITH MEAT PACKING PLANT	W	0000126	01S/04W-22M01S		1999	0	0	0	0	0	0					
SMITH TRACT WELL COMPANY	W	3600001	01S/03W-21R02S	11	1978	0	0	0	0	0	0					
SMITH TRACT WELL COMPANY	W	3600001-	01S/03W-21R01S		1972	0	0	0	0	0	0					
SMITH,	W	0000124	01N/04W-14J			1	1	1	1	1	1					
SMITH,	W	0000125	01S/03W-02J			10	20	20	7	37	19					
SOJKA, DONALD R.	W	3601173	01S/03W-32K		1980	0	0	0	0	0	0					
SOLANO WELL NO 3	W	3602003	01S/02W-16C	3		64	74	62	48	76	65					
SOMERS, R.	D	3601093	01N/04W-24H	SPRING	1974	0	0	0	0	0	0					
SOUTHERN CALIFORNIA EDISON	W	3690723	01S/04W-10F01S	HANFORD1	1981	0	0	0	0	0	0					
SOUZA, JOHN	W	3601084	01S/02W-20K		1980	0	0	0	0	0	0					
SPRING PACIFIC PROPERTY LLC	W	3601750	01S/03W-18L	ACQUIL/MARIGOLD	2004	0	0	0	0	0	0					
STANLEY, SILAS	W	0000127	01S/02W-24H		2007	0	0	0	0	0	0					
STEWART, WILLARD	W	0000128	01S/03W-31D		1978	0	0	0	0	0	0					
STORKSON, DAVID D.	W	3600083	01N/05W-06P	1		65	57	64	30	59	55					
STORKSON, DAVID D.	W	3602664	01N/05W-06M01S	SPRING NO 1		35	31	28	26	30	30					
STRAWBERRY PATCH	W	0000129	01S/03W-03N		2006	0	0	0	0	0	0					
STRAWBERRY PATCH	W	0000130	01S/03W-03N		2006	0	0	0	0	0	0					
SUNRISE RANCH PARTNERSHIP	W	3600599	01S/02W-13F	1	1991	0	0	0	0	0	0					
SUNRISE RANCH PARTNERSHIP	W	3600600	01S/02W-14L	SUNRISE 2	1981	0	0	0	0	0	0					
SUNRISE RANCH PARTNERSHIP	W	3600601	01S/02W-14F	SUN 3A	1981	0	0	0	0	0	0					
SUNRISE RANCH PARTNERSHIP	W	3600602	01S/02W-15P	SUNRISE 4	1981	0	0	0	0	0	0					
SUNRISE RANCH PARTNERSHIP	W	3600603	01S/02W-15G	SUNRISE 5	1991	0	0	0	0	0	0					
SUNRISE RANCH PARTNERSHIP	W	3601640	01S/02W-14N	SUN 6	1991	0	0	0	0	0	0					

**WESTERN - SAN BERNARDINO WATERMASTER
VERIFIED PRODUCTION DATA - NON PLAINTIFFS
CROSS INDEX BY OWNER
SAN BERNARDINO BASIN**

OWNER	WELL TYPE	RECRD TN NUMBER	STATE WELL NUMBER	LOCAL DESIGNATION	YEAR CLOSED	-----CALENDAR YEAR EXTRACTIONS-----										
						2008	2009	2010	2011	2012	AVG					
SUNRISE RANCH PARTNERSHIP	W	3601969	01S/02W-14L	SUNRISE 7	1991	0	0	0	0	0	0	0	0	0	0	
SUPERIOR ORCHARDS	D	0000131	01N/03W-29B	TUNNEL DIV.	1985	0	0	0	0	0	0	0	0	0	0	
SYCAMORE HEIGHTS WATER COMPANY INC	W	3601837	01N/03W-34B	HERCULES	1962	0	0	0	0	0	0	0	0	0	0	
SYCAMORE HEIGHTS WATER COMPANY INC	W	3601838	01N/03W-34A	WALKISHA	1962	0	0	0	0	0	0	0	0	0	0	
TENNESSEE MUTUAL WELL COMPANY	W	3601161	01S/03W-16L	PIONEER 1		208	212	173	178	178	178	211	248			
TENNESSEE WATER COMPANY	W	3600474	01S/03W-16L	1		309	303	226	192	192	211	248				
TERRACE WATER COMPANY	W	3601684	01S/04W-08F06S	LARGE 1	1978	0	0	0	0	0	0	0	0	0	0	
TERRACE WATER COMPANY	W	3601684	01S/04W-08F12S	#1 SMALL, 50 HP SUB		255	399	268	392	252	313					
TERRACE WATER COMPANY	W	3601685	01S/04W-08F14S	SMALL 2	1962	0	0	0	0	0	0	0	0	0	0	
TERRACE WATER COMPANY	W	3601686	01S/04W-08F14S	#2 LARGE WELL, 100HP		558	389	433	314	499	439					
TEXACO GAS STATION	W	0000027	01S/04W-24J		1984	0	0	0	0	0	0	0	0	0	0	
THOMPSON, RANDALL	D	0000132	01N/03W-28A	SPRING DIV.	2005	0	0	0	0	0	0	0	0	0	0	
TILDEN, M WILLIAM	W	3602074	01N/03W-34B02S	IRRIG 1	2007	0	0	0	0	0	0	0	0	0	0	
TILDEN, M WILLIAM	W	3602075	01N/03W-34B01S	DOM 2	1972	0	0	0	0	0	0	0	0	0	0	
TRAMMELL CROW COMPANY	W	3600524	01S/03W-17L01S	NEVADA ST	2006	0	0	0	0	0	0	0	0	0	0	
TRI-CITY CONCRETE	W	3600935	01N/04W-31N	WILSON 2	1978	0	0	0	0	0	0	0	0	0	0	
TRI-CITY CONCRETE	W	3601309	01S/04W-05M	PLANT	1979	0	0	0	0	0	0	0	0	0	0	
TRI-CITY MUTUAL WATER COMPANY	W	0000133	01S/04W-23N		1971	0	0	0	0	0	0	0	0	0	0	
TRI-CITY MUTUAL WATER COMPANY	W	3601823	01S/04W-23K		1964	0	0	0	0	0	0	0	0	0	0	
TRIPLE FALLS MUTUAL WATER COMPANY	W	0000134	01S/01W-19G		1975	0	0	0	0	0	0	0	0	0	0	
TRIPLE FALLS MUTUAL WATER COMPANY	W	0000135	01S/01W-20D		1975	0	0	0	0	0	0	0	0	0	0	
TRIPLE FALLS MUTUAL WATER COMPANY	W	0000136	01S/01W-20D		1975	0	0	0	0	0	0	0	0	0	0	
TROJAN GROVES	W	3600451	01S/03W-15M			1	1	0	1	1	1	1	1	1	1	
U. S. FOREST SERVICE	W	0000137	01N/04W-13Q	MAINT. YARD	1971	0	0	0	0	0	0	0	0	0	0	
U. S. FOREST SERVICE	W	0000138	01S/02W-13P	MILL CREEK	1965	0	0	0	0	0	0	0	0	0	0	
UNGER, V. E.	W	3601168	01S/04W-26F		1977	0	0	0	0	0	0	0	0	0	0	
UNIVERSITY OF REDLANDS	W	0000139	01S/02W-17A	PEPPER HOUSE		5	5	5	5	5	10	6				
UNKNOWN	W	0000181	01S/04W-14F	FOISTY STREET	2007	0	0	0	0	0	0	0	0	0	0	
VALENCIA AVE. MUTUAL WATER COMPANY	W	0000140	01N/04W-23K	WATERMAN AVE	2007	0	0	0	0	0	0	0	0	0	0	
VALLEY FARMS MUTUAL WATER COMPANY	W	0000141	01S/04W-15R	NO 1 WASHTN	2001	0	0	0	0	0	0	0	0	0	0	
VALLEY FARMS MUTUAL WATER COMPANY	W	0000142	01S/04W-15Q	NO 2 WELL	2001	0	0	0	0	0	0	0	0	0	0	
VAN MEETER,	W	0000146	01S/03W-02P	OLD WELL	2007	0	0	0	0	0	0	0	0	0	0	
VAN MEETER,	W	0000147	01S/03W-02P	NEW WELL	2007	0	0	0	0	0	0	0	0	0	0	
VANLEUVEN, CLARENCE	W	0000143	01S/04W-24J		1980	0	0	0	0	0	0	0	0	0	0	
VICTORIA FARMS MUTUAL WATER CO	W	3602112	01S/04W-13R01S		1966	0	0	0	0	0	0	0	0	0	0	
VICTORIA FARMS MUTUAL WATER CO	W	3602247	01S/04W-13R03S	2	1981	0	0	0	0	0	0	0	0	0	0	
VICTORIA FARMS MUTUAL WATER CO	W	3602574	01S/04W-13R04S	NO. 3	1999	0	0	0	0	0	0	0	0	0	0	

**WESTERN - SAN BERNARDINO WATERMASTER
VERIFIED PRODUCTION DATA - NON PLAINTIFFS
CROSS INDEX BY OWNER
SAN BERNARDINO BASIN**

OWNER	WELL TYPE	RECRD TN NUMBER	STATE WELL NUMBER	LOCAL DESIGNATION	YEAR CLOSED	-----CALENDAR YEAR EXTRACTATIONS-----																	
						1999	2000	2001	2002	2003	2004	2005	2006	2007	2008	2009	2010	2011	2012	AVG			
VICTORIA FARMS MUTUAL WATER CO	W	3602714	01S/04W-13R01S	NO 1	1999	0	0	0	0	0	0	0	0	0	0	0	0	0	0	0	0	0	0
VICTORIA GUERNSEY	W	3600399	01S/04W-02D	1	1968	0	0	0	0	0	0	0	0	0	0	0	0	0	0	0	0	0	0
VICTORIA SEVENTH DAY ADVENTIST	W	0000144	01S/04W-24J			10	10	10	10	10	10	10	10	10	10	10	10	10	10	10	10	10	10
VILLAGE LAKES	W	3600241	01S/03W-03Q	1-HOME		85	85	85	85	85	85	85	85	85	85	85	85	85	85	85	85	85	85
VULCAN - CAL MAT	W	3603695	01N/05W-25Q	HIGHLAND PLANT		863	0	0	0	0	0	0	0	0	0	0	0	0	0	0	0	0	173
VULCAN - CAL MAT	W	3603696	01N/05W-02N	CAJON CK AREA D		27	28	27	28	27	27	27	27	27	27	27	27	27	27	27	27	27	27
VULCAN - CAL MAT	W	3603697	01N/05W-14A	CAJON CK PLNG. "M"		196	196	196	196	196	196	196	196	196	196	196	196	196	196	196	196	196	
WALLACE,	W	0000148	01N/04W-14J		2012	1	1	1	1	1	1	1	1	1	1	1	1	1	1	1	1	1	1
WARD, FLOYD	W	0000149	01S/01W-18N	WELL NO. 1		0	0	0	0	0	0	0	0	0	0	0	0	0	0	0	0	0	0
WARD, FLOYD	W	0000150	01S/01W-18P	WELL NO. 2		0	0	0	0	0	0	0	0	0	0	0	0	0	0	0	0	0	0
WARD, FLOYD	W	0000151	01S/01W-18P	WELL NO. 3		1	1	1	1	1	1	1	1	1	1	1	1	1	1	1	1	1	1
WARD, FLOYD	W	0000152	01S/01W-18N	WELL NO. 4		0	0	0	0	0	0	0	0	0	0	0	0	0	0	0	0	0	0
WARD, FLOYD	W	0000153	01S/01W-18M	WELL NO. 6	2012	0	0	0	0	0	0	0	0	0	0	0	0	0	0	0	0	0	0
WARD, FLOYD	D	0000154	01S/01W-18P	LATERAL SPR S	2012	0	0	0	0	0	0	0	0	0	0	0	0	0	0	0	0	0	0
WARMINGTON, ROBERT P.	W	3600270	01S/03W-20P	RDLNDS 1	1979	0	0	0	0	0	0	0	0	0	0	0	0	0	0	0	0	0	0
WEATHERWAX, W. G.	W	3600652	01S/03W-15N01S	REDLANDS	1958	0	0	0	0	0	0	0	0	0	0	0	0	0	0	0	0	0	0
WESSON, ROBERT CRAIG	W	3601642	01S/02W-30B02S	KING ST		8	8	8	8	8	8	8	8	8	8	8	8	8	8	8	8	8	8
WEST VALLEY WATER DIST	W	3600302	01N/05W-26A01S	#03 / LOWER 2	1967	0	0	0	0	0	0	0	0	0	0	0	0	0	0	0	0	0	0
WEST VALLEY WATER DIST	W	3600303	01N/05W-26B01S	LOWER 4	1959	0	0	0	0	0	0	0	0	0	0	0	0	0	0	0	0	0	0
WEST VALLEY WATER DIST	W	3600304	01N/05W-26A03S	#04 / LOWER 5	2003	0	0	0	0	0	0	0	0	0	0	0	0	0	0	0	0	0	0
WEST VALLEY WATER DIST	W	3600305	01N/05W-25E01S	#05 / LOWER 6	2002	0	0	0	0	0	0	0	0	0	0	0	0	0	0	0	0	0	0
WEST VALLEY WATER DIST	W	3600306	01N/05W-23P02S	UPPER 2	1967	0	0	0	0	0	0	0	0	0	0	0	0	0	0	0	0	0	0
WEST VALLEY WATER DIST	W	3600307	01N/05W-23P04S	#01 / UPPER 4	2007	0	0	0	0	0	0	0	0	0	0	0	0	0	0	0	0	0	0
WEST VALLEY WATER DIST	D	3600312	01N/05W-22M	LYTLE CREEK		3,369	3,189	3,322	3,381	2,954	3,243												
WEST VALLEY WATER DIST	W	3600996	01N/05W-36J03S	#08 / LORD 1	2003	0	0	0	0	0	0	0	0	0	0	0	0	0	0	0	0	0	0
WEST VALLEY WATER DIST	W	3600997	01N/05W-36H04S	#07 / LORD #7		1,631	1,203	125	8	98	613												
WEST VALLEY WATER DIST	W	3600998	01N/05W-25E02S	#06 / FERG 1	1973	0	0	0	0	0	0	0	0	0	0	0	0	0	0	0	0	0	0
WEST VALLEY WATER DIST	W	3600999	01S/04W-06J01S	DIXON 1	1973	0	0	0	0	0	0	0	0	0	0	0	0	0	0	0	0	0	0
WEST VALLEY WATER DIST	W	3601000	01S/04W-06J02S	#12 / DIXON 2	1967	0	0	0	0	0	0	0	0	0	0	0	0	0	0	0	0	0	0
WEST VALLEY WATER DIST	W	3601002	01N/04W-31P03S	#09 / RAYNOR 1	1973	0	0	0	0	0	0	0	0	0	0	0	0	0	0	0	0	0	0
WEST VALLEY WATER DIST	W	3601003	01S/04W-06H02S	#13 / RAYNOR 4	1977	0	0	0	0	0	0	0	0	0	0	0	0	0	0	0	0	0	0
WEST VALLEY WATER DIST	D	3601725	01N/05W-25E		1977	0	0	0	0	0	0	0	0	0	0	0	0	0	0	0	0	0	0
WEST VALLEY WATER DIST	W	3601848	01S/04W-05E05S	#15 9TH & PENNSYLVAN		764	801	156	969	1,012	740												
WEST VALLEY WATER DIST	W	3601944	01N/05W-23Q01S	#02 / LOWER 7		1,905	1,707	1,522	677	2,151	1,592												
WEST VALLEY WATER DIST	W	3602766	01S/04W-06H03S	#30 WASHINGTON/BSLIN		930	459	616	366	669	608												
WEST VALLEY WATER DIST	W	3602897	01N/05W-23P	#34 GOLF COURSE	2008	0	0	0	0	0	0	0	0	0	0	0	0	0	0	0	0	0	0
WEST VALLEY WATER DIST	W	3603054	01N/05W-25E03S	#35 GOLF COURSE	2003	0	0	0	0	0	0	0	0	0	0	0	0	0	0	0	0	0	0

**WESTERN - SAN BERNARDINO WATERMASTER
 VERIFIED PRODUCTION DATA - NON PLAINTIFFS
 CROSS INDEX BY OWNER
 SAN BERNARDINO BASIN**

OWNER	WELL TYPE	RECRDTN NUMBER	STATE WELL NUMBER	LOCAL DESIGNATION	YEAR CLOSED	-----CALENDAR YEAR EXTRACTIONS-----										
						2008	2009	2010	2011	2012	2012	AVG				
WEST VALLEY WATER DIST	W	3603055	01N/05W-36H05S	#36 LORD RANCH		0	0	0	0	0	0	0	0	0	0	
WEST VALLEY WATER DIST	W	3603769	01N/05W-25E	#05A SYCAMORE VALLE		1,319	1,024	405	312	134	639					
WEST VALLEY WATER DIST	W	3603777	01N/05W-26A06S	#04A		1,338	1,020	766	1,694	1,571	1,278					
WEST VALLEY WATER DIST	W	3603778	01N/05W-36R06S	#08A		1,659	2,548	692	44	5	990					
WEST VALLEY WATER DIST	W	3603902	01N/05W-23P07S	#01A		839	765	382	246	43	455					
WESTERN FRUIT GROWERS	W	0000156	01S/03W-24Q		1979	0	0	0	0	0	0					
WIDEMEYER,	D	0000157	01N/03W-29H	SPRING DIV.	2005	0	0	0	0	0	0					
WIDEMEYER,	W	0000158	01N/03W-29H		2005	0	0	0	0	0	0					
WILEY, RUTH NORWOOD	W	3600052	01S/04W-36J	1	1974	0	0	0	0	0	0					
WILLIAMS DAIRY	W	0000159	01S/04W-11G		2005	0	0	0	0	0	0					
WILLIAMS WELL CORPORATION LTD	W	3600828	01S/03W-16J	-		394	363	421	388	460	405					
WOEHR MUTUAL WATER COMPANY	W	3600817	01S/03W-29H		1991	0	0	0	0	0	0					
WYAHIKU, PAUL	W	3601280	01S/03W-29D	SOUTH 1	1981	0	0	0	0	0	0					
YUCAIPA VALLEY WATER DISTRICT	W	3602657	01S/01W-20D01S	WELL NO 31	1980	0	0	0	0	0	0					
YUCAIPA VALLEY WATER DISTRICT	W	3602658	01S/01W-20D03S	WELL NO 32	1980	0	0	0	0	0	0					
YUCAIPA VALLEY WATER DISTRICT	W	3602659	01S/01W-19B02S	WELL NO 33	1997	0	0	0	0	0	0					
YUCAIPA VALLEY WATER DISTRICT	W	3603539	01S/02W-24C01S	YVWD 51/MILL CREEK		161	99	166	97	120	129					

189,335 169,860 160,639 165,053 175,002 171,978

TOTALS FOR 794 WELLS

SAN BERNARDINO BASIN AREA,
CROSS INDEX BY STATE WELL NUMBER

WESTERN - SAN BERNARDINO WATERMASTER
 VERIFIED PRODUCTION DATA - NON PLAINTIFFS
 CROSS INDEX BY STATE WELL NUMBER
 SAN BERNARDINO BASIN

STATE WELL NUMBER	RECRDTN NUMBER	OWNER	WELL TYPE	LOCAL DESIGNATION	YEAR CLOSED	-----CALENDAR YEAR EXTRACTIONS-----										
						1974	2008	2009	2010	2011	2012	AVG				
01N/02W-10N	3600027	BEAR VALLEY MUTUAL WATER COMPANY	D		1974	0	0	0	0	0	0	0	0	0	0	0
01N/02W-26H	3600021	BEAR VALLEY MUTUAL WATER COMPANY	W	SANTA A1		182	0	0	0	0	0	0	0	0	0	36
01N/02W-26H	3600022	BEAR VALLEY MUTUAL WATER COMPANY	W	SA #2	1998	0	0	0	0	0	0	0	0	0	0	0
01N/03W-19F	3600864	EAST VALLEY WATER DISTRICT	W	PL 79	2003	0	0	0	0	0	0	0	0	0	0	0
01N/03W-19F	3600971	EAST VALLEY WATER DISTRICT	W	PL 58/LT SAND CK	2000	0	0	0	0	0	0	0	0	0	0	0
01N/03W-19G	3600970	EAST VALLEY WATER DISTRICT	W	PL 57	2000	0	0	0	0	0	0	0	0	0	0	0
01N/03W-19Q	0000122	SELEY,	D	TUNNEL DIV.	2007	0	0	0	0	0	0	0	0	0	0	0
01N/03W-19R	0000160	SAN MANUEL INDIAN RESERVATION	W	DOMESTIC		1	1	1	1	1	1	1	1	1	1	1
01N/03W-19R	0000161	SAN MANUEL INDIAN RESERVATION	W			15	15	15	15	15	15	15	15	15	15	15
01N/03W-19R	0000162	SAN MANUEL INDIAN RESERVATION	D	YORK TUNNEL		0	0	0	0	0	0	0	0	0	0	0
01N/03W-20N	0000119	SAN MANUEL INDIAN RESERVATION	W			0	0	0	0	0	0	0	0	0	0	0
01N/03W-25Q	3602474	EAST HIGHLAND RANCH	D	PLUNGE/BOX SPRING	2004	0	0	0	0	0	0	0	0	0	0	0
01N/03W-27M	3600681	CITY CREEK WATER COMPANY	D	CITY CREEK	2000	0	0	0	0	0	0	0	0	0	0	0
01N/03W-27M	3600856	GUERTH, WILLIAM H.	D	CITY CREEK	1967	0	0	0	0	0	0	0	0	0	0	0
01N/03W-27N02S	3600378	EAST VALLEY WATER DISTRICT	W	PL 134/CC3	2003	0	0	0	0	0	0	0	0	0	0	0
01N/03W-27N08S	3600377	EAST VALLEY WATER DISTRICT	W	PL 134/CC1	2003	0	0	0	0	0	0	0	0	0	0	0
01N/03W-27R	0000018	COOK CANYON	D			0	0	0	0	0	0	0	0	0	0	0
01N/03W-28A	0000132	THOMPSON, RANDALL	D	SPRING DIV.	2005	0	0	0	0	0	0	0	0	0	0	0
01N/03W-28N01S	3600184	HIGHLAND WELL COMPANY	W	HWC 1	1974	0	0	0	0	0	0	0	0	0	0	0
01N/03W-28PO1S	3600855	EAST VALLEY WATER DISTRICT	W	PL 54		0	0	0	0	0	0	0	0	0	0	0
01N/03W-29B	0000131	SUPERIOR ORCHARDS	D	TUNNEL DIV.	1985	0	0	0	0	0	0	0	0	0	0	0
01N/03W-29H	0000157	WIDEMEYER,	D	SPRING DIV.	2005	0	0	0	0	0	0	0	0	0	0	0
01N/03W-29H	0000158	WIDEMEYER,	W		2005	0	0	0	0	0	0	0	0	0	0	0
01N/03W-29M	3600924-	CALIF DEPT OF MENTAL HEALTH- PLANT OPERA	W	2A		155	25	25	1	5	11	39				
01N/03W-29M	3602381	CALIF DEPT OF MENTAL HEALTH- PLANT OPERA	W	14		43	28	28	0	0	0	14				
01N/03W-29M01S	3600924	CALIF DEPT OF MENTAL HEALTH- PLANT OPERA	W	PATTON 2	1978	0	0	0	0	0	0	0	0	0	0	0
01N/03W-29N01S	3600931	CALIF DEPT OF MENTAL HEALTH- PLANT OPERA	W	PATTON10		0	0	0	0	0	0	0	0	0	0	0
01N/03W-29R01S	3600025	BEAR VALLEY MUTUAL WATER COMPANY	W	PALM AV3	1977	0	0	0	0	0	0	0	0	0	0	0
01N/03W-30C	0000030	EAST VALLEY WATER DISTRICT	W	PLANT NO 36	1958	0	0	0	0	0	0	0	0	0	0	0
01N/03W-30H01S	3600444	EAST VALLEY WATER DISTRICT	W	PL 98		0	0	0	0	0	0	0	0	0	0	0
01N/03W-30J	3600221	EAST VALLEY WATER DISTRICT	W	PL 63	2001	0	0	0	0	0	0	0	0	0	0	0
01N/03W-30J	3600545	EAST VALLEY WATER DISTRICT	W	PL 62	2003	0	0	0	0	0	0	0	0	0	0	0
01N/03W-30J05S	3602274	EAST VALLEY WATER DISTRICT	W	PL 39		921	1,084	937	1,086	896	985					
01N/03W-30N01S	3602113	EAST VALLEY WATER DISTRICT	W	PL 41		0	0	0	0	0	0	0	0	0	0	0
01N/03W-31A	0000034	EAST VALLEY WATER DISTRICT	W	PLANT NO 45	2005	0	0	0	0	0	0	0	0	0	0	0
01N/03W-31B01S	3600927	EAST VALLEY WATER DISTRICT	W	PL 116	2003	0	0	0	0	0	0	0	0	0	0	0
01N/03W-31B01S	3609927	SAN BERNARDINO, CITY OF	W	PATTON 6	1984	0	0	0	0	0	0	0	0	0	0	0

**WESTERN - SAN BERNARDINO WATERMASTER
VERIFIED PRODUCTION DATA - NON PLAINTIFFS
CROSS INDEX BY STATE WELL NUMBER
SAN BERNARDINO BASIN**

STATE WELL NUMBER	RECRDTN NUMBER	OWNER	WELL TYPE	LOCAL DESIGNATION	YEAR CLOSED	-----CALENDAR YEAR EXTRACTIONS-----										AVG
						2008	2009	2010	2011	2012						
01N/03W-31C02S	3601884	EAST VALLEY WATER DISTRICT	W	PL 30	2000	0	0	0	0	0	0	0	0	0	0	
01N/03W-31D	0000038	EAST VALLEY WATER DISTRICT	W	PLANT NO 70	2005	0	0	0	0	0	0	0	0	0	0	
01N/03W-31K02S	3600929	CALIF DEPT OF MENTAL HEALTH- PLANT OPERA	W	PATTON 8	1967	0	0	0	0	0	0	0	0	0	0	
01N/03W-31L01S	3600269	EAST VALLEY WATER DISTRICT	W	PL 68	2007	0	0	0	0	0	0	0	0	0	0	
01N/03W-31L02S	3600928	EAST VALLEY WATER DISTRICT	W	PL 117	2003	0	0	0	0	0	0	0	0	0	0	
01N/03W-31L03S	3600930	EAST VALLEY WATER DISTRICT	W	PL 118	2003	0	0	0	0	0	0	0	0	0	0	
01N/03W-31P02S	3600747	FRIEDEMANN, ERNEST C.	W	WELL 1	1971	0	0	0	0	0	0	0	0	0	0	
01N/03W-31Q	0000008	BASELINE LAUNDRY	W		1990	0	0	0	0	0	0	0	0	0	0	
01N/03W-31Q	0000082	BASELINE LAUNDRY	W		1990	0	0	0	0	0	0	0	0	0	0	
01N/03W-32B	3600275	EAST VALLEY WATER DISTRICT	W	PL 64	2003	0	0	0	0	0	0	0	0	0	0	
01N/03W-32C01S	3600923	CALIF DEPT OF MENTAL HEALTH- PLANT OPERA	W	PATTON 1	1972	0	0	0	0	0	0	0	0	0	0	
01N/03W-32C02S	3601930	CALIF DEPT OF MENTAL HEALTH- PLANT OPERA	W	PATTON11	2009	0	0	0	0	0	0	0	0	0	0	
01N/03W-32D	3600630	MILLER MUTUAL WELL COMPANY	W		1961	0	0	0	0	0	0	0	0	0	0	
01N/03W-32M	3600630-	MILLER MUTUAL WELL COMPANY	W		2005	5	5	5	5	5	5	5	5	5	5	
01N/03W-32M	0000085	NO NAME WELL	W		2005	0	0	0	0	0	0	0	0	0	0	
01N/03W-33C01S	3600765	DUCKWORTH, JOHN E.	W	113		1	0	0	0	0	0	0	0	0	0	
01N/03W-33F01S	3601184	EAST VALLEY WATER DISTRICT	W	PL 94 / CORWIN		0	0	0	0	0	0	0	0	0	0	
01N/03W-33H01S	3601584	EAST VALLEY WATER DISTRICT	W	PL 47	2003	0	0	0	0	0	0	0	0	0	0	
01N/03W-33M01S	3600374	EAST VALLEY WATER DISTRICT	W	PL 138/PALM 1	2000	0	0	0	0	0	0	0	0	0	0	
01N/03W-33M02S	3601069	EAST VALLEY WATER DISTRICT	W	CHURCH	1987	0	0	0	0	0	0	0	0	0	0	
01N/03W-33R02S	3600456	BASE LINE WELL COMPANY	W	1	1959	0	0	0	0	0	0	0	0	0	0	
01N/03W-34A	3601838	SYCAMORE HEIGHTS WATER COMPANY INC	W	WALKISHA	1962	0	0	0	0	0	0	0	0	0	0	
01N/03W-34B	3601837	SYCAMORE HEIGHTS WATER COMPANY INC	W	HERCULES	1962	0	0	0	0	0	0	0	0	0	0	
01N/03W-34B01S	3602075	TILDEN, M WILLIAM	W	DOM 2	1972	0	0	0	0	0	0	0	0	0	0	
01N/03W-34B02S	3602074	TILDEN, M WILLIAM	W	IRRIG 1	2007	0	0	0	0	0	0	0	0	0	0	
01N/03W-34C02S	3601631	BRISTOL RANCH	W	1	1972	0	0	0	0	0	0	0	0	0	0	
01N/03W-34F	0000095	NORWOOD,	W		2007	0	0	0	0	0	0	0	0	0	0	
01N/03W-34H	0000004	ARNOLD RANCH	W		1978	0	0	0	0	0	0	0	0	0	0	
01N/03W-34K	0000006	BALDWIN,	W		1978	0	0	0	0	0	0	0	0	0	0	
01N/03W-34K	0000114	RULE,	W	SPRING	1974	0	0	0	0	0	0	0	0	0	0	
01N/03W-34Q	0000163	PATTERSON, ROY H.	W		2007	0	0	0	0	0	0	0	0	0	0	
01N/03W-35B	0000029	EAST HIGHLANDS ORANGE COMPANY	D	BOX SPRING	1980	0	0	0	0	0	0	0	0	0	0	
01N/03W-35G	3600605	EAST HIGHLAND RANCH	D	PLUNGE CK		0	0	0	0	0	0	0	0	0	0	
01N/03W-35K	3600606	EAST HIGHLAND RANCH	D	ELDER GULCH		0	0	0	0	0	0	0	0	0	0	
01N/04W-06A01S	3603580	SAN BERNARDINO, CITY OF	W	DEVIL CYN #6		194	182	176	201	196	190					
01N/04W-06A02S	3603579	SAN BERNARDINO, CITY OF	W	DEVIL CYN #7		92	66	67	77	81	77					
01N/04W-06H01S	3602205	SAN BERNARDINO, CITY OF	W	DEVIL CANYON #4		28	13	4	5	3	11					

**WESTERN - SAN BERNARDINO WATERMASTER
VERIFIED PRODUCTION DATA - NON PLAINTIFFS
CROSS INDEX BY STATE WELL NUMBER
SAN BERNARDINO BASIN**

STATE WELL NUMBER	RECRD TN NUMBER	OWNER	WELL TYPE	LOCAL DESIGNATION	YEAR CLOSED	-----CALENDAR YEAR EXTRACTIONS-----										
						2008	2009	2010	2011	2012	AVG					
01N/04W-06H02S	3602206	SAN BERNARDINO, CITY OF	W	DEVIL CANYON #3	1977	141	56	9	0	0	1	1	41			
01N/04W-06J	3600738	SAN BERNARDINO, CITY OF	D	DEVIL CYN DIVERSION		0	0	0	0	0	0	0	0			
01N/04W-07F01S	3600711	SAN BERNARDINO, CITY OF	W	DEVIL CANYON #2	2012	1,040	964	1,525	1,318	665	1,102	1,102				
01N/04W-08M01S	3600712	SAN BERNARDINO, CITY OF	W	DEVIL CANYON #1		659	1,192	1,053	1,070	892	973	973				
01N/04W-08M02S	3602844	SAN BERNARDINO, CITY OF	W	DEVIL CANYON #5		272	458	282	148	210	274	274				
01N/04W-08N	0000054	ELLENA, JOHN B.	W		1977	0	0	0	0	0	0	0				
01N/04W-08P01S	3602712	CALIFORNIA STATE UNIVERSITY, SAN BERNARDI	W	ELLENA BROS.		0	0	0	0	0	0	0				
01N/04W-13N	0000063	HARRISON CANYON	W		2012	0	0	0	0	0	0	0				
01N/04W-13N	0000064	HARRISON CANYON	W			0	0	0	0	1	0	0				
01N/04W-13P	0000026	DILLSON MUTUAL WATER COMPANY	W	HARRISON CYN	1969	0	0	0	0	0	0	0				
01N/04W-13Q	0000061	HARDISON,	W	KING STREET MUTUAL		1	1	1	1	1	1	1				
01N/04W-13Q	0000137	U. S. FOREST SERVICE	W	MAINT. YARD	1971	0	0	0	0	0	0	0				
01N/04W-14A	3601811	CAMPUS CRUSADE FOR CHRIST	D	EAST TWIN		3	0	0	0	0	0	1				
01N/04W-14A	3601979	CAMPUS CRUSADE FOR CHRIST	D	EAST TWIN	1981	0	0	0	0	0	0	0				
01N/04W-14C	3601376	LULY, LUCIAN L	D	WATERMAN	1960	0	0	0	0	0	0	0				
01N/04W-14C	3601377	LULY, LUCIAN L	D	WATERMAN	1960	0	0	0	0	0	0	0				
01N/04W-14C	3601378	LULY, LUCIAN L	D	WATERMAN	1960	0	0	0	0	0	0	0				
01N/04W-14C	3603938	CAMPUS CRUSADE FOR CHRIST	D	WEST TWIN CRK		40	40	40	40	40	40	40				
01N/04W-14J	0000014	BOUCHER,	W		2012	1	1	1	1	1	0	1				
01N/04W-14J	0000121	SATOSKI,	W			1	1	1	1	1	1	1				
01N/04W-14J	0000124	SMITH,	W			1	1	1	1	1	1	1				
01N/04W-14J	0000148	WALLACE,	W		2012	1	1	1	1	1	0	1				
01N/04W-14P03S	3603472	SAN BERNARDINO, CITY OF	W	40TH & VALENCIA		67	21	217	141	181	125	125				
01N/04W-14R	0000009	BATCHELOR,	W			1	1	1	1	1	1	1				
01N/04W-14R	0000010	BATCHELOR,	D		2012	1	1	1	1	1	0	1				
01N/04W-14R	0000073	KING,	W			1	1	1	1	1	1	1				
01N/04W-16E01S	3600714	SAN BERNARDINO, CITY OF	W	NEWMARK #1		495	223	132	257	253	272	272				
01N/04W-16E02S	3600715	SAN BERNARDINO, CITY OF	W	NEWMARK #2		808	415	188	383	741	507	507				
01N/04W-16E03S	3600716	SAN BERNARDINO, CITY OF	W	NEWMARK #3		1,588	1,312	1,154	1,545	1,504	1,421	1,421				
01N/04W-16E04S	3602399	SAN BERNARDINO, CITY OF	W	NEWMARK #4		1,554	366	901	1,527	1,573	1,184	1,184				
01N/04W-16M03S	3603693	SAN BERNARDINO, CITY OF	W	EPA #6		529	593	438	513	551	525	525				
01N/04W-16M04S	3603694	SAN BERNARDINO, CITY OF	W	EPA #7		2,074	2,130	1,917	884	1,799	1,761	1,761				
01N/04W-17A01S	3603930	CALIFORNIA STATE UNIVERSITY, SAN BERNARDI	W	IRRIGATION WELL 1		208	185	162	165	185	181	181				
01N/04W-23E	3601810	DEL ROSA MUTUAL WATER COMPANY	W	PRKSD 2	1981	0	0	0	0	0	0	0				
01N/04W-23E	3601925	ARROWHEAD COUNTRY CLUB	W	1		531	472	396	385	433	443	443				
01N/04W-23K	0000140	VALENCIA AVE. MUTUAL WATER COMPANY	W	WATERMAN AVE	2007	0	0	0	0	0	0	0				
01N/04W-24A	3600218	LANGSTON-NEWBY DEVELOPMENT COMPANY	W	1	1980	0	0	0	0	0	0	0				

**WESTERN - SAN BERNARDINO WATERMASTER
VERIFIED PRODUCTION DATA - NON PLAINTIFFS
CROSS INDEX BY STATE WELL NUMBER
SAN BERNARDINO BASIN**

STATE WELL NUMBER	RECRD TN NUMBER	OWNER	WELL TYPE	LOCAL DESIGNATION	YEAR CLOSED	-----CALENDAR YEAR EXTRACTIONS-----										
						1969	2008	2009	2010	2011	2012	AVG				
01N/04W-24C	000025	DILLSON MUTUAL WATER COMPANY	W	DILLSON AVE	1969	0	0	0	0	0	0	0	0	0	0	0
01N/04W-24C	000173	DILLSON MUTUAL WATER COMPANY	W	CISCO WELL		0	0	0	0	0	0	0	0	0	0	0
01N/04W-24H	3600865	LA BONTE, JIM	W	MULTOWN2		4	4	4	4	4	4	4	4	4	4	4
01N/04W-24H	3601093	SOMERS, R.	D	SPRING	1974	0	0	0	0	0	0	0	0	0	0	0
01N/04W-25A01S	3601675	EAST VALLEY WATER DISTRICT	W	PL 27		805	510	211	1	0	0	0	0	0	0	305
01N/04W-25B	3601672	EAST VALLEY WATER DISTRICT	W	PL 25	2000	0	0	0	0	0	0	0	0	0	0	0
01N/04W-25C02S	3601673	EAST VALLEY WATER DISTRICT	W	PL 25A		250	128	333	646	790	429					
01N/04W-25C04S	3602370	EAST VALLEY WATER DISTRICT	W	PL 107		499	1,342	1,399	926	954	1,024					
01N/04W-25D	0000048	EAST VALLEY WATER DISTRICT	W	PLANT NO 85	2005	0	0	0	0	0	0	0	0	0	0	0
01N/04W-25G01S	3601674	EAST VALLEY WATER DISTRICT	W	PL 26	2003	0	0	0	0	0	0	0	0	0	0	0
01N/04W-25K01S	3600643	EAST VALLEY WATER DISTRICT	W	PL 66	2003	0	0	0	0	0	0	0	0	0	0	0
01N/04W-25R	0000003	ANDERSON, W.D.	W		1999	0	0	0	0	0	0	0	0	0	0	0
01N/04W-26A02S	3601671	EAST VALLEY WATER DISTRICT	W	PL 24A		415	330	416	1,063	784	602					
01N/04W-26A03S	3602337	EAST VALLEY WATER DISTRICT	W	PL 24B		1,818	1,355	398	46	1,683	1,060					
01N/04W-26A10S	3601670	EAST VALLEY WATER DISTRICT	W	PL 24	2000	0	0	0	0	0	0	0	0	0	0	0
01N/04W-26E02S	3600727	SAN BERNARDINO, CITY OF	W	LYNWOOD		1,460	1,071	1,049	302	244	825					
01N/04W-26H	3601809	DEL ROSA MUTUAL WATER COMPANY	W	GOLDNAVI	1967	0	0	0	0	0	0	0	0	0	0	0
01N/04W-26M	3600743	MT. VIEW CEMETERY	W	MT VIEW #1 (#2 SHED)		141	126	119	111	161	132					
01N/04W-26N	3600742	MT. VIEW CEMETERY	W	1	1978	0	0	0	0	0	0	0	0	0	0	0
01N/04W-26N	3600742-	MT. VIEW CEMETERY	W	MT VIEW #2 (#3 WEST)		104	109	123	151	114	120					
01N/04W-26P03S	3601115	SAN BERNARDINO, CITY OF	W	PERRIS HILL 5		1	1	1	1	0	0	0	0	0	0	1
01N/04W-27A01S	3600728	SAN BERNARDINO, CITY OF	W	WATERMAN AVE.		1,293	1,163	1,247	1,563	1,570	1,367					
01N/04W-27A02S	3602401	SAN BERNARDINO, CITY OF	W	LEROY		822	883	335	579	612	646					
01N/04W-27B01S	3602081	SAN BERNARDINO, CITY OF	W	31ST ST. & MT VIEW		298	361	141	240	205	249					
01N/04W-27G01S	3600719	SAN BERNARDINO, CITY OF	W	30TH ST.		1,810	1,478	1,176	272	136	974					
01N/04W-27M01S	3600721	SAN BERNARDINO, CITY OF	W	25TH & N. "E" ST.		0	0	0	0	0	0	0	0	0	0	0
01N/04W-27M02S	3600720	SAN BERNARDINO, CITY OF	W	27TH ST. & ACACIA		512	261	152	229	435	318					
01N/04W-27N01S	3602264	SAN BERNARDINO, CITY OF	W	23RD ST.	2010	0	0	0	0	0	0	0	0	0	0	0
01N/04W-29E	3601879	SAN BERNARDINO, CITY OF	W	GARDENA		0	0	0	0	0	0	0	0	0	0	0
01N/04W-29E01S	3601878	SAN BERNARDINO, CITY OF	W	DARBY		0	0	0	0	0	0	0	0	0	0	0
01N/04W-29F01S	3601880	SAN BERNARDINO, CITY OF	W	COLIMA	2007	0	0	0	0	0	0	0	0	0	0	0
01N/04W-30M01S	3601845	SAN BERNARDINO, CITY OF	W	MALLORY NO. 3		337	593	366	903	667	571					
01N/04W-31A01S	3600319	MOUNT VERNON WATER CO.	W	1		927	1,132	167	685	799	742					
01N/04W-31H	3601588	SAN BERNARDINO, CITY OF	W	STATE 1		0	0	0	0	0	0	0	0	0	0	0
01N/04W-31M03S	3603262	HOLLIDAY TRUCKING	W	SB #1		59	61	59	60	60	60					
01N/04W-31N	3600935	TRI-CITY CONCRETE	W	WILSON 2	1978	0	0	0	0	0	0	0	0	0	0	0
01N/04W-31N02S	3601085	RIALTO, CITY OF	W	CITY 4 / #1	1992	0	0	0	0	0	0	0	0	0	0	0

**WESTERN - SAN BERNARDINO WATERMASTER
VERIFIED PRODUCTION DATA - NON PLAINTIFFS
CROSS INDEX BY STATE WELL NUMBER
SAN BERNARDINO BASIN**

STATE WELL NUMBER	RECRD TN NUMBER	OWNER	WELL TYPE	LOCAL DESIGNATION	YEAR CLOSED	2008	2009	2010	2011	2012	AVG
01N/04W-31P03S	3601002	WEST VALLEY WATER DIST	W	#09 / RAYNOR 1	1973	0	0	0	0	0	0
01N/04W-32D03S	3600717	SAN BERNARDINO, CITY OF	W	19TH ST #1		348	0	0	0	0	70
01N/04W-32D04S	3600718	SAN BERNARDINO, CITY OF	W	19TH ST #2		289	1,171	1,085	786	617	790
01N/04W-32N01S	3602400	SAN BERNARDINO, CITY OF	W	BASELINE & CALIFORNI		339	347	160	172	102	224
01N/04W-32Q	3603790	SAN BERNARDINO, CITY OF	W	EPA 112		2,472	2,177	1,698	1,329	1,665	1,868
01N/04W-32R	3603789	SAN BERNARDINO, CITY OF	W	EPA 111		2,284	2,129	2,497	2,469	2,206	2,317
01N/04W-33N	3603788	SAN BERNARDINO, CITY OF	W	EPA 110		2,493	2,253	1,683	1,464	1,649	1,908
01N/04W-33P	3603787	SAN BERNARDINO, CITY OF	W	EPA 109		1,997	1,751	1,431	1,402	1,430	1,602
01N/04W-33R	3603786	SAN BERNARDINO, CITY OF	W	EPA 108		2,362	2,399	1,882	2,070	2,256	2,194
01N/04W-33R03S	3603917	SAN BERNARDINO, CITY OF	W	EPA 108S		924	925	891	929	765	887
01N/04W-34G01S	3600725	SAN BERNARDINO, CITY OF	W	17 ST/SIERRA WAY #1		0	0	0	0	0	0
01N/04W-34G03S	3600726	SAN BERNARDINO, CITY OF	W	16TH ST & SIERRA WAY		1,554	2,382	2,002	2,162	2,487	2,117
01N/04W-34G04	3603208	SAN BERNARDINO, CITY OF	W	17TH ST. & SIERRA #2		282	76	279	17	16	134
01N/04W-35C01S	3601114	SAN BERNARDINO, CITY OF	W	PERRIS HILL 2	1981	0	0	0	0	0	0
01N/04W-35C02S	3601116	SAN BERNARDINO, CITY OF	W	PERRIS HILL 3	2007	0	0	0	0	0	0
01N/04W-35C03S	3601117	SAN BERNARDINO, CITY OF	W	PERRIS HILL 4		0	1	1	0	1	1
01N/04W-35H	0000096	PACIFIC HIGH SCHOOL	W		1965	0	0	0	0	0	0
01N/04W-35J02S	3600457	BASELINE GARDENS MUTUAL WATER COMPANY	W	1 STANDBY	1992	0	0	0	0	0	0
01N/04W-35K	3602067	SAN BERNARDINO, CITY OF	W	2-GILBERT/CANYON RD		0	0	0	0	0	0
01N/04W-35L06S	3603932	SAN BERNARDINO COUNTY - FACILITY MANAGE	W	COUNTY HOSP-GIBERT		118	0	4	0	0	24
01N/04W-35M03S	3600729	SAN BERNARDINO, CITY OF	W	GILBERT ST.		1,012	78	88	36	222	287
01N/04W-35N	0000097	PIERSON,	W		1999	0	0	0	0	0	0
01N/04W-35R	3604012	BASELINE GARDENS MUTUAL WATER COMPANY	W	WELL #4		0	0	0	0	0	0
01N/04W-35R01S	3602528	BASELINE GARDENS MUTUAL WATER COMPANY	W	#3-7251 BARTON ST	2013	424	336	217	0	0	195
01N/04W-36F03S	3601186	CONEJO RANCHOS MUTUAL WATER COMPANY	W	1	1957	0	0	0	0	0	0
01N/04W-36F08S	3601666	EAST VALLEY WATER DISTRICT	W	PL 16	2003	0	0	0	0	0	0
01N/04W-36H	0000036	EAST VALLEY WATER DISTRICT	W	PLANT NO 52	2005	0	0	0	0	0	0
01N/04W-36H06S	3601669	EAST VALLEY WATER DISTRICT	W	PL 23	2000	0	0	0	0	0	0
01N/04W-36K	3601654	EAST VALLEY WATER DISTRICT	W	PL 1A / FISHER	2000	0	0	0	0	0	0
01N/04W-36K04S	3601653	EAST VALLEY WATER DISTRICT	W	PL 1	2000	0	0	0	0	0	0
01N/04W-36K05S	3601655	EAST VALLEY WATER DISTRICT	W	PL 2	2000	0	0	0	0	0	0
01N/04W-36M01S	3600458	BASELINE GARDENS MUTUAL WATER COMPANY	W	PS & B 2		0	0	0	0	0	0
01N/04W-36Q01S	3601656	EAST VALLEY WATER DISTRICT	W	PL 6	2003	0	0	0	0	0	0
01N/04W-36R10S	3601658	EAST VALLEY WATER DISTRICT	W	PL 8	2003	0	0	0	0	0	0
01N/05W-01R	3600760	MEYER, CHARLES R	W	1	1991	0	0	0	0	0	0
01N/05W-02N	3603696	VULCAN - CAL MAT	W	CAJON CK AREA D		27	28	27	27	27	27
01N/05W-03A02S	3602821	SAN BERNARDINO, CITY OF	W	CAJON #3		954	823	578	696	946	799

**WESTERN - SAN BERNARDINO WATERMASTER
VERIFIED PRODUCTION DATA - NON PLAINTIFFS
CROSS INDEX BY STATE WELL NUMBER
SAN BERNARDINO BASIN**

STATE WELL NUMBER	RECRD TN NUMBER	OWNER	WELL TYPE	LOCAL DESIGNATION	YEAR CLOSED	-----CALENDAR YEAR EXTRACTIONS-----										
						2008	2009	2010	2011	2012	AVG					
01N/05W-03A03S	3603792	SAN BERNARDINO, CITY OF	W	CAJON 4		1,558	1,348	1,283	1,397	2,285	1,574					
01N/05W-03H01S	3601843	SAN BERNARDINO, CITY OF	W	CAJON NO 1		0	0	0	0	0	0					
01N/05W-03H02S	3601844	SAN BERNARDINO, CITY OF	W	CAJON NO 2		1,094	1,160	1,366	1,673	1,443	1,347					
01N/05W-04B	3603933	SAN BERNARDINO COUNTY - REGIONAL PARKS	W	GLEN HELEN 1A (2)		34	40	39	4	39	31					
01N/05W-04M	0000105	REGINA GRAPE PRODUCTS	W	WELL NO. 1	1985	0	0	0	0	0	0					
01N/05W-04N	0000106	REGINA GRAPE PRODUCTS	W	WELL NO. 2	1985	0	0	0	0	0	0					
01N/05W-04N	0000107	REGINA GRAPE PRODUCTS	W	WELL NO. 3	1985	0	0	0	0	0	0					
01N/05W-04N	0000110	REGINA GRAPE PRODUCTS	W	WELL NO. 5	1985	0	0	0	0	0	0					
01N/05W-04N	0000111	REGINA GRAPE PRODUCTS	W	WELL NO. 6	1985	0	0	0	0	0	0					
01N/05W-04N	0000112	REGINA GRAPE PRODUCTS	W	WELL NO. 7	1985	0	0	0	0	0	0					
01N/05W-05C	0000108	REGINA GRAPE PRODUCTS	D	SPRING DIV.	1985	0	0	0	0	0	0					
01N/05W-05R	0000109	REGINA GRAPE PRODUCTS	W	WELL NO. 4	1985	0	0	0	0	0	0					
01N/05W-06E	3600591	FONTANA UNION WATER COMPANY	W	BL AND FTF	1992	0	0	0	0	0	0					
01N/05W-06E	3600739	SAN BERNARDINO, CITY OF	D	LYTLE CK DIV.		0	0	0	0	0	0					
01N/05W-06G01S	3600582	FONTANA UNION WATER COMPANY	W	FU 27		419	121	170	255	1	193					
01N/05W-06K02S	3600586	FONTANA UNION WATER COMPANY	W	FU 33		1,482	1,559	1,028	553	1,382	1,201					
01N/05W-06M01S	3602664	STORKSON, DAVID D.	W	SPRING NO 1		35	31	28	26	30	30					
01N/05W-06P	3600083	STORKSON, DAVID D.	W	1		65	57	64	30	59	55					
01N/05W-07C	3601381	NEALEY MUTUAL WATER COMPANY	D		1958	0	0	0	0	0	0					
01N/05W-07H01S	3600581	FONTANA UNION WATER COMPANY	W	FU 26		385	57	855	1,001	903	640					
01N/05W-14A	3603697	VULCAN - CAL MAT	W	CAJON CK PLNG. "M"		196	196	103	107	92	139					
01N/05W-15Q02S	3600566	FONTANA UNION WATER COMPANY	W	FU 8	1962	0	0	0	0	0	0					
01N/05W-15Q02S	3602727	FONTANA UNION WATER COMPANY	W	FU 8		1,165	106	1	595	1,054	584					
01N/05W-16K01S	3600585	FONTANA UNION WATER COMPANY	W	FU 32		852	778	1,135	1,435	1,352	1,110					
01N/05W-22A01S	3600569	FONTANA UNION WATER COMPANY	W	FU 13		2,512	2,161	1,360	1,585	2,586	2,041					
01N/05W-22C02S	3600563	FONTANA UNION WATER COMPANY	W	FU 4		1,501	1,274	922	1,976	2,272	1,589					
01N/05W-22F01S	3600580	FONTANA UNION WATER COMPANY	W	FU 25		222	0	0	0	0	44					
01N/05W-22F02S	3600562	FONTANA UNION WATER COMPANY	W	FU 3		1,361	1,018	653	1,303	1,747	1,216					
01N/05W-22F03S	3600579	FONTANA UNION WATER COMPANY	W	FU 24		624	715	950	871	1,308	894					
01N/05W-22M	3600312	WEST VALLEY WATER DIST	D	LYTLE CREEK		3,369	3,189	3,322	3,381	2,954	3,243					
01N/05W-22M	3600320	SAN BERNARDINO, CITY OF	D	MT VERNON		0	0	0	0	0	0					
01N/05W-22M	3601718	RIALTO, CITY OF	D	FILTER		1,165	1,123	1,210	1,171	1,311	1,196					
01N/05W-23A01S	3601499	MUSCOY MUTUAL WATER COMPANY NO. 1	W	MUSCOY 2		463	80	314	413	393	333					
01N/05W-23A02S	3601500	MUSCOY MUTUAL WATER COMPANY NO. 1	W	MUSCOY 3		463	87	322	416	453	348					
01N/05W-23H01S	3601497	MUSCOY MUTUAL WATER COMPANY NO. 1	W	MUSCOY 1		460	1,203	379	318	375	547					
01N/05W-23K01S	3600561	FONTANA UNION WATER COMPANY	W	FU 1	1987	0	0	0	0	0	0					
01N/05W-23P	3602897	WEST VALLEY WATER DIST	W	#34 GOLF COURSE	2008	0	0	0	0	0	0					

**WESTERN - SAN BERNARDINO WATERMASTER
VERIFIED PRODUCTION DATA - NON PLAINTIFFS
CROSS INDEX BY STATE WELL NUMBER
SAN BERNARDINO BASIN**

STATE WELL NUMBER	RECRD TN NUMBER	OWNER	WELL TYPE	LOCAL DESIGNATION	YEAR CLOSED	-----CALENDAR YEAR EXTRACTIONS-----									
						2008	2009	2010	2011	2012	AVG				
01N/05W-23P02S	3600306	WEST VALLEY WATER DIST	W	UPPER 2	1967	0	0	0	0	0	0	0	0	0	0
01N/05W-23P04S	3600307	WEST VALLEY WATER DIST	W	#01 / UPPER 4	2007	0	0	0	0	0	0	0	0	0	0
01N/05W-23P07S	3603902	WEST VALLEY WATER DIST	W	#01A		839	765	382	246	43	455				
01N/05W-23Q01S	3601263	RIALTO, CITY OF	W	CITY #1		241	1	0	0	0	48				
01N/05W-23Q01S	3601944	WEST VALLEY WATER DIST	W	#02 / LOWER 7		1,905	1,707	1,522	677	2,151	1,592				
01N/05W-23Q02S	3602080	RIALTO, CITY OF	W	CITY #2		2,565	1,961	2,102	1,336	842	1,761				
01N/05W-24D01S	3601498	MUSCOY MUTUAL WATER COMPANY NO. 1	W	LACY #5		375	317	450	308	308	352				
01N/05W-24E01S	3602345	MUSCOY MUTUAL WATER COMPANY NO. 1	W	MUSCOY 4		203	40	161	236	222	172				
01N/05W-25E	3601725	WEST VALLEY WATER DIST	D		1977	0	0	0	0	0	0				
01N/05W-25E	3603769	WEST VALLEY WATER DIST	W	#05A SYCAMORE VALLE		1,319	1,024	405	312	134	639				
01N/05W-25E01S	3600305	WEST VALLEY WATER DIST	W	#05 / LOWER 6	2002	0	0	0	0	0	0				
01N/05W-25E02S	3600998	WEST VALLEY WATER DIST	W	#06 / FERG 1	1973	0	0	0	0	0	0				
01N/05W-25E03S	3603054	WEST VALLEY WATER DIST	W	#35 GOLF COURSE	2003	0	0	0	0	0	0				
01N/05W-25E05S	3603695	VULCAN - CAL MAT	W	HIGHLAND PLANT		863	0	0	0	0	173				
01N/05W-26A01S	3600302	WEST VALLEY WATER DIST	W	#03 / LOWER 2	1967	0	0	0	0	0	0				
01N/05W-26A03S	3600304	WEST VALLEY WATER DIST	W	#04 / LOWER 5	2003	0	0	0	0	0	0				
01N/05W-26A06S	3603777	WEST VALLEY WATER DIST	W	#04A		1,338	1,020	766	1,694	1,571	1,278				
01N/05W-26B01S	3600303	WEST VALLEY WATER DIST	W	LOWER 4	1959	0	0	0	0	0	0				
01N/05W-36B01S	3602848	RIALTO, CITY OF	W	CITY #3		147	23	33	0	24	45				
01N/05W-36H04S	3600997	WEST VALLEY WATER DIST	W	#07 / LORD #7		1,631	1,203	125	8	98	613				
01N/05W-36H05S	3603055	WEST VALLEY WATER DIST	W	#36 LORD RANCH		0	0	0	0	0	0				
01N/05W-36J01S	3603027	SAN BERNARDINO, CITY OF	W	LYTLE CK #2		652	659	500	737	622	634				
01N/05W-36J03S	3600996	WEST VALLEY WATER DIST	W	#08 / LORD 1	2003	0	0	0	0	0	0				
01N/05W-36R01S	3600713	SAN BERNARDINO, CITY OF	W	LYTLE CREEK # 3-1		0	0	0	0	0	0				
01N/05W-36R06S	3603778	WEST VALLEY WATER DIST	W	#08A		1,659	2,548	692	44	5	990				
01S/01W-08H01S	3601282	REDLANDS, CITY OF	W	MILL CREEK #1		0	0	0	0	0	0				
01S/01W-09J01S	3603045	REDLANDS, CITY OF	W	MILL CK #2A		0	256	9	0	0	53				
01S/01W-10L01S	3601285	REDLANDS, CITY OF	W	MILL CREEK #2		2,096	1,399	2,537	2,403	2,349	2,157				
01S/01W-11Q01S	3601288	REDLANDS, CITY OF	W	MILL CREEK #4		775	816	128	0	387	421				
01S/01W-18M	0000153	WARD, FLOYD	W	WELL NO. 6	2012	0	0	0	0	0	0				
01S/01W-18N	0000149	WARD, FLOYD	W	WELL NO. 1		0	0	0	0	0	1				
01S/01W-18N	0000152	WARD, FLOYD	W	WELL NO. 4		0	0	0	0	0	1				
01S/01W-18P	0000150	WARD, FLOYD	W	WELL NO. 2		0	0	0	0	0	10				
01S/01W-18P	0000151	WARD, FLOYD	W	WELL NO. 3		1	1	1	0	1	1				
01S/01W-18P	0000154	WARD, FLOYD	D	LATERAL SPR S	2012	0	0	0	0	0	0				
01S/01W-19B02S	3602659	YUCAIPA VALLEY WATER DISTRICT	W	WELL NO 33	1997	0	0	0	0	0	0				
01S/01W-19G	0000134	TRIPLE FALLS MUTUAL WATER COMPANY	W		1975	0	0	0	0	0	0				

**WESTERN - SAN BERNARDINO WATERMASTER
VERIFIED PRODUCTION DATA - NON PLAINTIFFS
CROSS INDEX BY STATE WELL NUMBER
SAN BERNARDINO BASIN**

STATE WELL NUMBER	RECRD TN NUMBER	OWNER	WELL TYPE	LOCAL DESIGNATION	YEAR CLOSED	2008	2009	2010	2011	2012	AVG
01S/01W-20D	0000135	TRIPLE FALLS MUTUAL WATER COMPANY	W		1975	0	0	0	0	0	0
01S/01W-20D	0000136	TRIPLE FALLS MUTUAL WATER COMPANY	W		1975	0	0	0	0	0	0
01S/01W-20D01S	3602657	YUCAIPA VALLEY WATER DISTRICT	W	WELL NO 31	1980	0	0	0	0	0	0
01S/01W-20D03S	3602658	YUCAIPA VALLEY WATER DISTRICT	W	WELL NO 32	1980	0	0	0	0	0	0
01S/02W-04N	3600028	BEAR VALLEY MUTUAL WATER COMPANY	D	SANTA ANA RIVER MAIN		13,519	10,368	17,524	16,862	15,560	14,767
01S/02W-04N	3603900	SAN BERNARDINO COUNTY FLOOD CONTROL	W	DOMESTIC WELL NO. 3		4	4	4	10	4	5
01S/02W-06M	3600323	HIGHLAND ACRES RANCH	W	ELEC 1	1998	0	0	0	0	0	0
01S/02W-06Q	0000028	EAST HIGHLAND RANCH	D	TUNNEL DIVERSION		0	0	0	0	0	0
01S/02W-07B	3600604	EAST HIGHLAND RANCH	W	RANNEY	1986	0	0	0	0	0	0
01S/02W-07F01S	3602799	EAST VALLEY WATER DISTRICT	W	PL 125		1,134	965	845	1,412	1,447	1,161
01S/02W-08A	0000104	REDLANDS WATER COMPANY	D	REDLANDS WATER COM		625	654	629	739	529	635
01S/02W-08C01S	3600678	NORTH FORK WATER COMPANY	W	1	2001	0	0	0	0	0	0
01S/02W-08C02S	3600679	NORTH FORK WATER COMPANY	W	N FORK #2	2001	0	0	0	0	0	0
01S/02W-09L	0000101	REDLANDS ASSOCIATES	W	BLOCK NO. 11	1972	0	0	0	0	0	0
01S/02W-09L	0000102	REDLANDS ASSOCIATES	D	TUNNEL DIV.	1980	0	0	0	0	0	0
01S/02W-09L02S	3602530	BLUE GOOSE GROWERS INC	W	BLOCK 11	1980	0	0	0	0	0	0
01S/02W-09L03S	3602531	BLUE BANNER COMPANY	W	TUNNEL DIV		100	100	100	100	50	90
01S/02W-09P	0000100	REDLANDS ASSOCIATES	W	BLOCK NO. 6	1972	0	0	0	0	0	0
01S/02W-09P02S	3602529	BLUE GOOSE GROWERS INC	W	GRNSPOT 6	1980	0	0	0	0	0	0
01S/02W-09Q	3601628	COGBILL, CLINTON L.	W	2		50	50	50	50	50	50
01S/02W-09Q01S	3600187	LANDMARK LAND COMPANY	W	1, SOLANO WELL #1	2000	0	0	0	0	0	0
01S/02W-13A01S	3602351	REDLANDS, CITY OF	W	MILL CREEK 0-A		1	0	0	0	0	0
01S/02W-13B	0000103	REDLANDS, CITY OF	D	MILL CREEK DIV	1980	0	0	0	0	0	0
01S/02W-13F	3600599	SUNRISE RANCH PARTNERSHIP	W	1	1991	0	0	0	0	0	0
01S/02W-13P	0000138	U. S. FOREST SERVICE	W	MILL CREEK	1965	0	0	0	0	0	0
01S/02W-14F	3600601	SUNRISE RANCH PARTNERSHIP	W	SUN 3A	1981	0	0	0	0	0	0
01S/02W-14H	3601302	REDLANDS, CITY OF	D	COOLIE HAT - MILL CK		12,332	7,785	10,076	13,492	10,679	10,873
01S/02W-14L	3600600	SUNRISE RANCH PARTNERSHIP	W	SUNRISE 2	1981	0	0	0	0	0	0
01S/02W-14L	3601969	SUNRISE RANCH PARTNERSHIP	W	SUNRISE 7	1991	0	0	0	0	0	0
01S/02W-14N	3601640	SUNRISE RANCH PARTNERSHIP	W	SUN 6	1991	0	0	0	0	0	0
01S/02W-15G	3600603	SUNRISE RANCH PARTNERSHIP	W	SUNRISE 5	1991	0	0	0	0	0	0
01S/02W-15P	3600602	SUNRISE RANCH PARTNERSHIP	W	SUNRISE 4	1981	0	0	0	0	0	0
01S/02W-16C	3600188	GRAM-PATTERSON WELL	W	CRAMPAT2		531	596	415	415	534	498
01S/02W-16C	3602003	SOLANO WELL NO 3	W	3		64	74	62	48	76	65
01S/02W-16C01S	3600266	GREENSPOT MUTUAL WELL COMPANY	W	GRNSPTMU		215	311	141	138	188	199
01S/02W-16L	0000060	HAGAR,	W		2007	0	0	0	0	0	0
01S/02W-17A	0000139	UNIVERSITY OF REDLANDS	W	PEPPER HOUSE		5	5	5	5	10	6

**WESTERN - SAN BERNARDINO WATERMASTER
VERIFIED PRODUCTION DATA - NON PLAINTIFFS
CROSS INDEX BY STATE WELL NUMBER
SAN BERNARDINO BASIN**

STATE WELL NUMBER	RECRDTN NUMBER	OWNER	WELL TYPE	LOCAL DESIGNATION	YEAR CLOSED	-----CALENDAR YEAR EXTRACTATIONS-----										
						2007	2008	2009	2010	2011	2012	AVG				
01S/02W-17B	0000099	REDLANDS ASSOCIATES	W	#0	2007	0	0	0	0	0	0	0	0	0	0	0
01S/02W-17N	3600038	REDLANDS, CITY OF	D	DRY CREEK DIVERSION	1974	0	0	0	0	0	0	0	0	0	0	0
01S/02W-18M	3602171	REES & PERRICONE RANCH	W	1	1981	0	0	0	0	0	0	0	0	0	0	0
01S/02W-18Q	3602280	MENTONE CITRUS GROWERS	W	#2		518	587	531	531	802	871	662				
01S/02W-18R01S	3600139	MENTONE CITRUS GROWERS	W	1-PRH RANCH		148	153	117	114	114	71	121				
01S/02W-19A01S	3602792	REDLANDS, CITY OF	W	AGATE #2		1,551	1,910	1,199	83	278	1,004					
01S/02W-19D	3600024	BEAR VALLEY MUTUAL WATER COMPANY	W	WABASH 2	1974	0	0	0	0	0	0	0	0	0	0	0
01S/02W-19G01S	3600006	REDLANDS, CITY OF	W	E. LUGONIA #5		0	0	0	0	0	0	0	0	0	0	0
01S/02W-19J	0000083	MENTONE DOMESTIC WATER COMPANY	W		1978	0	0	0	0	0	0	0	0	0	0	0
01S/02W-19J	0000176	MENTONE DOMESTIC WATER COMPANY	W	3 1971	1975	0	0	0	0	0	0	0	0	0	0	0
01S/02W-19J01S	3602653	REDLANDS, CITY OF	W	2	1979	0	0	0	0	0	0	0	0	0	0	0
01S/02W-19J02S	3602654	REDLANDS, CITY OF	W	CRAFTON		421	514	342	144	392	363					
01S/02W-19K01S	3601308	REDLANDS, CITY OF	W	AGATE 1		0	0	50	139	0	38					
01S/02W-20B01S	3602791	REDLANDS, CITY OF	W	EAST LUGONIA #4		0	0	88	0	0	18					
01S/02W-20D01S	3602896	REDLANDS, CITY OF	W	MADEIRA		667	626	555	555	32	487					
01S/02W-20G	3603967	JACINTO FARMING, LARRY	W	SAPPHIRE							1					
01S/02W-20K	3601084	SOUZA, JOHN	W		1980	0	0	0	0	0	0	0	0	0	0	0
01S/02W-20K	3602020	FAR WELL	W	F A R		74	70	29	0	0	35					
01S/02W-21B02S	3601287	REDLANDS, CITY OF	W	EAST LUGONIA #3		8	83	167	52	18	66					
01S/02W-21D01S	3601290	REDLANDS, CITY OF	W	EAST LUGONIA #6		0	33	16	0	0	10					
01S/02W-21E01S	3601284	REDLANDS, CITY OF	W	MAGUET #2		0	0	0	0	0	24					
01S/02W-21E02S	3601286	REDLANDS, CITY OF	W	MAGUET #3		0	0	0	0	0	0					
01S/02W-21H01S	3600981	REYNOLDS, BILL	W		1957	0	0	0	0	0	0	0	0	0	0	0
01S/02W-21L01S	3600226	HEAD, JOE T.	W	1	1960	0	0	0	0	0	0	0	0	0	0	0
01S/02W-21L02S	3602186	CRAFTON WATER COMPANY	W	2-GARNETIZANJA		0	0	0	0	0	0	0	0	0	0	0
01S/02W-21M01S	3601281	REDLANDS, CITY OF	W	MAGUET #1		0	0	0	0	0	0	0	0	0	0	0
01S/02W-22C	0000166	GREENSPOT MUTUAL WATER CO. TUNNEL	D			50	50	50	50	50	50	50	50	50	50	50
01S/02W-22C02S	3601283	REDLANDS, CITY OF	W	EAST LUGONIA #2		0	0	0	0	0	0	0	0	0	0	0
01S/02W-22E	0000013	BLISS,	W		1988	0	0	0	0	0	0	0	0	0	0	0
01S/02W-22E	0000056	FARROW,	W			5	5	5	5	5	5	5	5	5	5	5
01S/02W-22F	0000098	RAMSEY,	D	SPRING DIV	2007	0	0	0	0	0	0	0	0	0	0	0
01S/02W-24C	0000055	ELLGOOD,	W			0	0	0	0	0	0	0	0	0	0	0
01S/02W-24C01S	3603539	YUCAIPA VALLEY WATER DISTRICT	W	YVWD 51/MILL CREEK		161	99	166	97	120	129					
01S/02W-24H	0000127	STANLEY, SILAS	W		2007	0	0	0	0	0	0	0	0	0	0	0
01S/02W-28M	0000078	DANGERMOND, JACK	W	LA TOURETTE	2005	0	0	0	0	0	0	0	0	0	0	0
01S/02W-28M	0000079	DANGERMOND, JACK	D	SPRING DIV.		1	1	1	1	1	1	1	1	1	1	1
01S/02W-29C	0000057	FINCH,	W	FINCH	2004	0	0	0	0	0	0	0	0	0	0	0

**WESTERN - SAN BERNARDINO WATERMASTER
VERIFIED PRODUCTION DATA - NON PLAINTIFFS
CROSS INDEX BY STATE WELL NUMBER
SAN BERNARDINO BASIN**

STATE WELL NUMBER	RECRD TN NUMBER	OWNER	WELL TYPE	LOCAL DESIGNATION	YEAR CLOSED	-----CALENDAR YEAR EXTRACTIONS-----										
						2008	2009	2010	2011	2012	AVG					
01S/02W-29L	3602188	DANGERMOND, JACK	W	RANCHO LADERA-ESRI		215	333	0	0	0	0	0	0	110		
01S/02W-29M01S	3600238	HAPPE MUTUAL WELL COMPANY	W	1		24	97	71	10	63	67					
01S/02W-29N	3600272	CRAFTON WATER COMPANY	W	5TH AVE, # 1		684	530	99	10	14	267					
01S/02W-29N01S	3602062	BUOYE WELL	W	1	1977	0	0	0	0	0	0					
01S/02W-29N01S	3600313	CRAFTON WATER COMPANY	W	NYE	1967	0	0	0	0	0	0					
01S/02W-29P	3600017	SELBY DR & MRS	W	GRREES 3		0	0	0	0	0	0					
01S/02W-29P	3600018	REES-REES RANCHES INC	W	GRREES 2		0	0	0	0	0	0					
01S/02W-30B	3600240	HINCKLEY, HORACE P.	W	SOUTH WELL	1982	0	0	0	0	0	0					
01S/02W-30B	3601645	HINCKLEY, HORACE P.	W	1	1982	0	0	0	0	0	0					
01S/02W-30B02S	3601642	WESSON, ROBERT CRAIG	W	KING ST		8	8	4	14	14	10					
01S/02W-30C01S	3601641	REDLANDS UNIFIED SCHOOL DISTRICT	W	OPAL ST		140	201	98	59	109	121					
01S/02W-30G01S	3600530	KING STREET MUTUAL WELL COMPANY	W	1	1978	0	0	0	0	0	0					
01S/02W-30G02S	3600530-	KING STREET MUTUAL WELL COMPANY	W	2		5	5	5	5	5	5					
01S/02W-30H	3601126	GAY GROVE	W	1		40	55	39	32	38	41					
01S/02W-31B	0000067	HILL,	W		2004	0	0	0	0	0	0					
01S/02W-31F	3600483	SECHREST, RALPH F.	W	GPHRRCH1	1980	0	0	0	0	0	0					
01S/02W-31F	3601121	7TH AVE WELL	W	1	1979	0	0	0	0	0	0					
01S/02W-31M	3602170	ROBBINS, H W	W			5	5	5	5	5	5					
01S/02W-32B	0000074	KOCH,	W		2005	0	0	0	0	0	0					
01S/02W-32G01S	3601451	KOCH, GEORGE J.	W	1	1962	0	0	0	0	0	0					
01S/03W-01A	3601644	NORTH FORK WATER COMPANY	W	PLUNGE CK	2000	0	0	0	0	0	0					
01S/03W-01H01S	3600220	EAST VALLEY WATER DISTRICT	W	PLANT #142 / MT. H		425	445	624	503	600	519					
01S/03W-02J	0000125	SMITH,	W			10	20	20	7	37	19					
01S/03W-02J02S	3600680	EAST VALLEY WATER DISTRICT	W	PL 120 / CRAM		1,482	500	0	0	0	396					
01S/03W-02L	3600598	EAST HIGHLAND RANCH	W	NEW 1	1997	0	0	0	0	0	0					
01S/03W-02L01S	3600607	EAST HIGHLAND RANCH	W	SMALL	1978	0	0	0	0	0	0					
01S/03W-02L02S	3600607-	EAST HIGHLAND RANCH	W	WELL 3	1991	0	0	0	0	0	0					
01S/03W-02N02S	3603583	EAST VALLEY WATER DISTRICT	W	PLANT 143		617	895	981	620	966	816					
01S/03W-02P	0000146	VAN MEETER,	W	OLD WELL	2007	0	0	0	0	0	0					
01S/03W-02P	0000147	VAN MEETER,	W	NEW WELL	2007	0	0	0	0	0	0					
01S/03W-02P06S	3603734	EAST VALLEY WATER DISTRICT	W	PLANT 147		1,768	1,539	1,738	2,004	1,717	1,753					
01S/03W-03D	0000071	HUNTER,	W		1978	0	0	0	0	0	0					
01S/03W-03F	0000017	CLIFFSIDE RANCH	W		1978	0	0	0	0	0	0					
01S/03W-03F	3602079	BARNO, JOHN	W	1	1982	0	0	0	0	0	0					
01S/03W-03F02S	3600058	EAST VALLEY WATER DISTRICT	W	PL 53 / EUCALYPTUS	2001	0	0	0	0	0	0					
01S/03W-03F02S	3602571	EAST VALLEY WATER DISTRICT	W	PL 122	2000	0	0	0	0	0	0					
01S/03W-03N	0000047	EAST VALLEY WATER DISTRICT	W	PLANT NO 84	2005	0	0	0	0	0	0					

**WESTERN - SAN BERNARDINO WATERMASTER
VERIFIED PRODUCTION DATA - NON PLAINTIFFS
CROSS INDEX BY STATE WELL NUMBER
SAN BERNARDINO BASIN**

STATE WELL NUMBER	RECRDTN NUMBER	OWNER	WELL TYPE	LOCAL DESIGNATION	YEAR CLOSED	-----CALENDAR YEAR EXTRACTIONS-----											AVG	
						2008	2009	2010	2011	2012								
01S/03W-03N	0000049	EAST VALLEY WATER DISTRICT	W	PLANT NO 93	2005	0	0	0	0	0	0	0	0	0	0	0	0	0
01S/03W-03N	0000129	STRAWBERRY PATCH	W		2006	0	0	0	0	0	0	0	0	0	0	0	0	0
01S/03W-03N	0000130	STRAWBERRY PATCH	W		2006	0	0	0	0	0	0	0	0	0	0	0	0	0
01S/03W-03P	3601629	RIEDMAN, FRED M	W	1	1961	0	0	0	0	0	0	0	0	0	0	0	0	0
01S/03W-03Q	3600241	VILLAGE LAKES	W	1-HOME		85	85	85	85	85	85	85	85	85	85	85	85	85
01S/03W-03R01S	3601643	EAST VALLEY WATER DISTRICT	W	PL 121	2003	0	0	0	0	0	0	0	0	0	0	0	0	0
01S/03W-03R02S	3601639	EAST VALLEY WATER DISTRICT	W	PL 146 / 2		218	184	308	336	178	245							
01S/03W-03R04S	3603774	EAST VALLEY WATER DISTRICT	W	146A - 7938 CHURCH		1,010	880	228	168	871	631							
01S/03W-04C	3600466	EAST VALLEY WATER DISTRICT	W	PL 48	2000	0	0	0	0	0	0	0	0	0	0	0	0	0
01S/03W-04G02S	3601987	EAST VALLEY WATER DISTRICT	W	PL 136 / DUNKIRK 1		0	0	0	0	0	0	0	0	0	0	0	0	0
01S/03W-04G03S	3602560	EAST VALLEY WATER DISTRICT	W	PL 136 / DUNKIRK#2		0	0	0	0	0	0	0	0	0	0	0	0	0
01S/03W-04J01S	0000062	HARRISON,	W		2007	0	0	0	0	0	0	0	0	0	0	0	0	0
01S/03W-04J01S	3600026	GREENSPOT VILLAGE & MARKET PLACE LLC	W	PL 102		0	0	0	0	0	0	0	0	0	0	0	0	0
01S/03W-04N01S	3601978	EAST VALLEY WATER DISTRICT	W	PL 40		0	0	0	0	0	0	0	0	0	0	0	0	0
01S/03W-04N03S	3602338	EAST VALLEY WATER DISTRICT	W	PL 40A		0	23	1,009	441	499	394							
01S/03W-04P	0000032	EAST VALLEY WATER DISTRICT	W	PLANT NO 43	2005	0	0	0	0	0	0	0	0	0	0	0	0	0
01S/03W-04Q	0000059	EAST VALLEY WATER DISTRICT	W	PLANT NO 106	1974	0	0	0	0	0	0	0	0	0	0	0	0	0
01S/03W-04R	0000053	QUALITY FARMS	W	NO. 102	2007	0	0	0	0	0	0	0	0	0	0	0	0	0
01S/03W-05A02S	3601677	EAST VALLEY WATER DISTRICT	W	PL 31	2000	0	0	0	0	0	0	0	0	0	0	0	0	0
01S/03W-05B04S	3601678	EAST VALLEY WATER DISTRICT	W	PL 32	2000	0	0	0	0	0	0	0	0	0	0	0	0	0
01S/03W-05D	3600375	EAST VALLEY WATER DISTRICT	W	PL 132/CULL 1	2000	0	0	0	0	0	0	0	0	0	0	0	0	0
01S/03W-05D03S	3600376	EAST VALLEY WATER DISTRICT	W	PL 132/CULL 2		0	0	0	0	0	0	0	0	0	0	0	0	0
01S/03W-05D06S	3602260	EAST VALLEY WATER DISTRICT	W	PL 132 / CULL #3	2004	0	0	0	0	0	0	0	0	0	0	0	0	0
01S/03W-05D07S	3602417	EAST VALLEY WATER DISTRICT	W	PL 132 / CULL #4	2004	0	0	0	0	0	0	0	0	0	0	0	0	0
01S/03W-05D09S	3603904	EAST VALLEY WATER DISTRICT	W	132-5		2,032	1,544	835	1,479	924	1,363							
01S/03W-05J	0000050	EAST VALLEY WATER DISTRICT	W	PLANT NO 95	2005	0	0	0	0	0	0	0	0	0	0	0	0	0
01S/03W-05N05S	3601679	EAST VALLEY WATER DISTRICT	W	PL 38	2003	0	0	0	0	0	0	0	0	0	0	0	0	0
01S/03W-05Q	0000035	EAST VALLEY WATER DISTRICT	W	PLANT NO 46	2005	0	0	0	0	0	0	0	0	0	0	0	0	0
01S/03W-05Q	0000044	EAST VALLEY WATER DISTRICT	W	PLANT NO 80	2005	0	0	0	0	0	0	0	0	0	0	0	0	0
01S/03W-05R	0000033	EAST VALLEY WATER DISTRICT	W	PLANT NO 44	2005	0	0	0	0	0	0	0	0	0	0	0	0	0
01S/03W-06A05S	3601667	EAST VALLEY WATER DISTRICT	W	PL 21	2000	0	0	0	0	0	0	0	0	0	0	0	0	0
01S/03W-06B	0000040	EAST VALLEY WATER DISTRICT	W	PLANT NO 72	2005	0	0	0	0	0	0	0	0	0	0	0	0	0
01S/03W-06C	0000041	EAST VALLEY WATER DISTRICT	W	PLANT NO 74	2005	0	0	0	0	0	0	0	0	0	0	0	0	0
01S/03W-06E	0000039	EAST VALLEY WATER DISTRICT	W	PLANT NO 71	2005	0	0	0	0	0	0	0	0	0	0	0	0	0
01S/03W-06F	0000077	EAST VALLEY WATER DISTRICT	W	MCKINLEY ST.	2005	0	0	0	0	0	0	0	0	0	0	0	0	0
01S/03W-06H01S	3601659	EAST VALLEY WATER DISTRICT	W	PL 9	2000	0	0	0	0	0	0	0	0	0	0	0	0	0
01S/03W-06H04S	3601660	EAST VALLEY WATER DISTRICT	W	PL 9A		1,224	737	934	813	663	878							

**WESTERN - SAN BERNARDINO WATERMASTER
VERIFIED PRODUCTION DATA - NON PLAINTIFFS
CROSS INDEX BY STATE WELL NUMBER
SAN BERNARDINO BASIN**

STATE WELL NUMBER	RECRD TN NUMBER	OWNER	WELL TYPE	LOCAL DESIGNATION	YEAR CLOSED	-----CALENDAR YEAR EXTRACTS-----																	
						2003	2005	1959	2005	2005	2005	2005	2005	2005	1997	2007	2008	2009	2010	2011	2012	AVG	
01S/03W-06K01S	3601781	EAST VALLEY WATER DISTRICT	W	PL35/BASELINE MUTUAL	2003	0	0	0	0	0	0	0	0	0	0	0	0	0	0	0	0	0	0
01S/03W-06L	0000076	EAST VALLEY WATER DISTRICT	W	LANKERSHIM A	2005	0	0	0	0	0	0	0	0	0	0	0	0	0	0	0	0	0	0
01S/03W-06L	3600815	CHARLES, J. J.	W		1959	0	0	0	0	0	0	0	0	0	0	0	0	0	0	0	0	0	0
01S/03W-06L06S	3603926	EAST VALLEY WATER DISTRICT	W	WELL 151-HIGHLAND	2005	0	1,748	1,809	2,417	2,404	1,676	0	0	0	0	0	0	0	0	0	0	0	0
01S/03W-06M	0000045	EAST VALLEY WATER DISTRICT	W	PLANT NO 81	2005	0	0	0	0	0	0	0	0	0	0	0	0	0	0	0	0	0	0
01S/03W-06N	0000052	EAST VALLEY WATER DISTRICT	W	PLANT NO 97	2005	0	0	0	0	0	0	0	0	0	0	0	0	0	0	0	0	0	0
01S/03W-06P	0000043	EAST VALLEY WATER DISTRICT	W	PLANT NO 78	2005	0	0	0	0	0	0	0	0	0	0	0	0	0	0	0	0	0	0
01S/03W-06P18S	3603247	EAST VALLEY WATER DISTRICT	W	PL 141	2005	1,653	808	1,056	1,535	1,668	1,344	0	0	0	0	0	0	0	0	0	0	0	0
01S/03W-06Q	0000037	EAST VALLEY WATER DISTRICT	W	PLANT NO 69	2005	0	0	0	0	0	0	0	0	0	0	0	0	0	0	0	0	0	0
01S/03W-06Q	0000046	EAST VALLEY WATER DISTRICT	W	PLANT NO 83	2005	0	0	0	0	0	0	0	0	0	0	0	0	0	0	0	0	0	0
01S/03W-07A	0000090	INLAND VALLEY DEVELOPMENT AGENCY	W	LOCAL NO.11	1997	0	0	0	0	0	0	0	0	0	0	0	0	0	0	0	0	0	0
01S/03W-07A06S	3603649	SAN BERNARDINO, CITY OF	W	IVDA 11 (NORTON #11)	2007	70	101	61	59	84	75	0	0	0	0	0	0	0	0	0	0	0	0
01S/03W-07D	3603646	INLAND VALLEY DEVELOPMENT AGENCY	W	NORTON #2A	2005	0	0	0	0	0	0	0	0	0	0	0	0	0	0	0	0	0	0
01S/03W-08E	0000093	INLAND VALLEY DEVELOPMENT AGENCY	W	LOCAL NO.347	2005	0	0	0	0	0	0	0	0	0	0	0	0	0	0	0	0	0	0
01S/03W-08M	0000094	INLAND VALLEY DEVELOPMENT AGENCY	W	LOCAL NO.865	2005	0	0	0	0	0	0	0	0	0	0	0	0	0	0	0	0	0	0
01S/03W-09E	3601420	CEMEX CONSTRUCTION MATERIALS PACIFIC, LL	W	ALABAMA 2	2007	184	174	174	174	184	178	0	0	0	0	0	0	0	0	0	0	0	0
01S/03W-10D01S	3601839	MCCALLA, ROBERT	W	1	2007	0	0	0	0	0	0	0	0	0	0	0	0	0	0	0	0	0	0
01S/03W-10J	3603653	CEMEX CONSTRUCTION MATERIALS PACIFIC, LL	W	ORANGE STREET	2007	127	79	12	0	0	44	0	0	0	0	0	0	0	0	0	0	0	0
01S/03W-10K01S	3603766	REDLANDS, CITY OF	W	NORTH ORANGE #1	2005	2,232	1,823	1,208	614	2,043	1,584	0	0	0	0	0	0	0	0	0	0	0	0
01S/03W-10K02S	3603767	REDLANDS, CITY OF	W	NORTH ORANGE #2	2005	2,741	1,760	1,987	1,024	2,087	1,920	0	0	0	0	0	0	0	0	0	0	0	0
01S/03W-13C	0000080	L. P. R. RANCH	W		1972	0	0	0	0	0	0	0	0	0	0	0	0	0	0	0	0	0	0
01S/03W-13C	3602525	L P RICE COMPANY WELL	W	LPR ICE CO	1991	0	0	0	0	0	0	0	0	0	0	0	0	0	0	0	0	0	0
01S/03W-13H02S	3602895	REDLANDS, CITY OF	W	AIRPORT #1	2005	1,369	1,285	1,426	1,367	1,695	1,428	0	0	0	0	0	0	0	0	0	0	0	0
01S/03W-13M	3603762	REDLANDS, CITY OF	W	AIRPORT 2	2005	754	888	346	102	248	468	0	0	0	0	0	0	0	0	0	0	0	0
01S/03W-13P	3602224	EAST PIONEER MUTUAL WELL COMPANY	W		1991	0	0	0	0	0	0	0	0	0	0	0	0	0	0	0	0	0	0
01S/03W-13P01S	3600749	REDLANDS, CITY OF	W	MENTONE ACRES #2-NE	2005	813	0	155	1,743	1,357	814	0	0	0	0	0	0	0	0	0	0	0	0
01S/03W-13Q01S	3603116	SAN BERNARDINO VALLEY M.W.D.	W	SB AVE #1/BIG BEAR	2005	761	462	291	618	875	601	0	0	0	0	0	0	0	0	0	0	0	0
01S/03W-14E01S	3603656	REDLANDS, CITY OF	W	CHURCH STREET	2005	172	253	204	679	1,115	485	0	0	0	0	0	0	0	0	0	0	0	0
01S/03W-14P	3600125	SAN BERNARDINO AVE WATER CO.	W	1	2005	0	0	0	0	0	0	0	0	0	0	0	0	0	0	0	0	0	0
01S/03W-14P01S	3600642	PIONEER MUTUAL WATER CO	W	SBDNO 1	2005	30	20	21	22	24	23	0	0	0	0	0	0	0	0	0	0	0	0
01S/03W-14R01S	3602193	RAUGHT MUTUAL WELL COMPANY	W	RAUGHT	2005	204	248	215	239	255	232	0	0	0	0	0	0	0	0	0	0	0	0
01S/03W-15A01S	3602127	GOLDEN BEAR FOREST PRODUCTS	W	1	1991	0	0	0	0	0	0	0	0	0	0	0	0	0	0	0	0	0	0
01S/03W-15F01S	3601586	REDLANDS, CITY OF	W	ORANGE STREET	2005	567	694	1,065	1,406	1,600	1,066	0	0	0	0	0	0	0	0	0	0	0	0
01S/03W-15G	3600628	REDLANDS TRAP/SKEET	W		1980	0	0	0	0	0	0	0	0	0	0	0	0	0	0	0	0	0	0
01S/03W-15M	3600451	TROJAN GROVES	W		2005	1	1	0	1	1	1	0	0	0	0	0	0	0	0	0	0	0	0
01S/03W-15N	3603943	REDLANDS, CITY OF	W	WEATHERWAX #2	2005	32	33	32	32	55	37	0	0	0	0	0	0	0	0	0	0	0	0
01S/03W-15N01S	3600652	WEATHERWAX, W. G.	W	REDLANDS	1958	0	0	0	0	0	0	0	0	0	0	0	0	0	0	0	0	0	0

**WESTERN - SAN BERNARDINO WATERMASTER
VERIFIED PRODUCTION DATA - NON PLAINTIFFS
CROSS INDEX BY STATE WELL NUMBER
SAN BERNARDINO BASIN**

STATE WELL NUMBER	RECRD TN NUMBER	OWNER	WELL TYPE	LOCAL DESIGNATION	YEAR CLOSED	-----CALENDAR YEAR EXTRACTIONS-----									
						1974	2008	2009	2010	2011	2012	AVG			
01S/03W-15R01S	3600296	NORTHBRAE WATER COMPANY	W	1	1974	0	0	0	0	0	0	0	0	0	0
01S/03W-16A	3600527	RAMIREZ, J. J.	W	MIDAS		125	119	98	96	95	107				
01S/03W-16F	3600484	RAMIREZ, J. J.	W	BUCKEYE2		0	0	0	0	0	0				
01S/03W-16J	3600828	WILLIAMS WELL CORPORATION LTD	W	-		394	363	421	388	460	405				
01S/03W-16L	3600474	TENNESSEE WATER COMPANY	W	1		309	303	226	192	211	248				
01S/03W-16L	3601161	TENNESSEE MUTUAL WELL COMPANY	W	PIONEER 1		208	212	173	178	178	190				
01S/03W-16L	3602320-	NEW ENGLAND WATER COMPANY	W			229	250	200	195	360	247				
01S/03W-17C03S	0000023	DANIELS, HAROLD	W	DOMESTIC WELL	2005	0	0	0	0	0	0				
01S/03W-17G	0000081	MARSHBURN,	W			100	100	100	100	100	100				
01S/03W-17G	3600076	ARMSTRONG, DOUGLAS	W	2	1971	0	0	0	0	0	0				
01S/03W-17H01S	3600525	RAMIREZ, J. J.	W	ALABAMA	2007	0	0	0	0	0	0				
01S/03W-17L01S	3600524	TRAMMELL CROW COMPANY	W	NEVADA ST	2006	0	0	0	0	0	0				
01S/03W-17R	0000022	DANIELS, HAROLD	W	RANCH	1973	0	0	0	0	0	0				
01S/03W-17R	3600554	FAIRVIEW WATER COMPANY	W	FAIRVW 1		266	286	102	80	71	161				
01S/03W-17R04S	3602550	DANIELS RANCH	W	ALABAMA ST	2006	0	0	0	0	0	0				
01S/03W-18C	3603650	INLAND VALLEY DEVELOPMENT AGENCY	W	NORTON GOLF COURSE		75	0	0	0	0	15				
01S/03W-18H01S	3601748	BARTON DEVELOPMENT	W	CALIF	1978	0	0	0	0	0	0				
01S/03W-18L	3601750	SPRING PACIFIC PROPERTY LLC	W	ACQUIL/MARIGOLD	2004	0	0	0	0	0	0				
01S/03W-18M01S	3603796	MOUNTAIN VIEW POWER CO.	W	MVL MID-AQUIFER #2		1,073	935	838	449	356	730				
01S/03W-18N02S	3601015	MOUNTAIN VIEW POWER CO.	W	MT VIEW STMP2 #67		89	257	131	64	10	110				
01S/03W-18N03S	3601014	MOUNTAIN VIEW POWER CO.	W	MTN. VIEW STPM 66		389	103	260	256	403	282				
01S/03W-18N04S	3604011	MOUNTAIN VIEW POWER CO.	W	AUX 2A	2005	0	0	0	0	0	0				
01S/03W-18N06S	3603795	MOUNTAIN VIEW POWER CO.	W	MVL MID-AQUIFER #1		1,031	972	1,172	1,225	1,864	1,253				
01S/03W-18R	3603761	REDLANDS, CITY OF	W	CALIF.ST. IRRIGATION		588	654	501	509	627	576				
01S/03W-19A01S	3601748-	BARTON DEVELOPMENT	W	CALIF	1996	0	0	0	0	0	0				
01S/03W-19A01S	3603554	BARTON DEVELOPMENT C/O LUCKY FARMS	W	CALIF ST		379	215	345	336	194	294				
01S/03W-19B01S	3601749	MARIGOLD FARMS COMPANY	W	JAP	1974	0	0	0	0	0	0				
01S/03W-19G	3600418	BARTON DEVELOPMENT C/O LUCKY FARMS	W	LUGONIA		256	280	259	252	250	259				
01S/03W-19J	0000175	DANIELS, DON	W		1973	0	0	0	0	0	0				
01S/03W-19J07S	3602549	PHARAOHS LOST KINDGOM	W	CALIF ST		50	50	50	33	30	43				
01S/03W-19L	3600757	MARIGOLD FARMS COMPANY	W	2, MISSION #2		250	250	250	289	225	253				
01S/03W-19L01S	3600756	REDLANDS, CITY OF	W	MISSION #1		0	0	0	0	0	0				
01S/03W-19N	3601352	GENERAL AMERICAN LIFE	W	LANGFORD		62	62	62	62	62	62				
01S/03W-20A	3600449	BELL, EUGENE	W	CALVARY CHAPEL		108	139	73	20	1	68				
01S/03W-20A03S	3603919	CALVARY CHAPEL SCHOOL	W	SCHOOL IRRIGATION		10	10	10	10	85	40				
01S/03W-20C	3601172	K INV/ EVCA/ Y UN WELL	W		2007	0	0	0	0	0	0				
01S/03W-20F	3601171	SAN BERNARDINO COUNTY - FACILITY MANAGE	W	1/CRIM	2007	0	0	0	0	0	0				

**WESTERN - SAN BERNARDINO WATERMASTER
VERIFIED PRODUCTION DATA - NON PLAINTIFFS
CROSS INDEX BY STATE WELL NUMBER
SAN BERNARDINO BASIN**

STATE WELL NUMBER	RECRDTN NUMBER	OWNER	WELL TYPE	LOCAL DESIGNATION	YEAR CLOSED	-----CALENDAR YEAR EXTRACTIONS-----										
						2007	2008	2009	2010	2011	2012	AVG				
01S/03W-20F03S	3602241	CARTER, JAMES	W	ALMOND	2007	0	0	0	0	0	0	0	0	0	0	0
01S/03W-20H01S	3600182	GLADYSTA WELL & WATER COMPANY	W	1	1978	0	0	0	0	0	0	0	0	0	0	0
01S/03W-20H02S	3600182-	GLADYSTA WELL & WATER COMPANY	W			51	65	88	88	99	143	89				
01S/03W-20P	3600270	WARMINGTON, ROBERT P.	W	RDLNDS 1	1979	0	0	0	0	0	0	0	0	0	0	0
01S/03W-20Q	0000164	MCCALLA BROS.	W		1984	0	0	0	0	0	0	0	0	0	0	0
01S/03W-20R	3600091	JEWEL WATER COMPANY	W	1	1976	0	0	0	0	0	0	0	0	0	0	0
01S/03W-20R01S	3600123	NICKERSON WATER COMPANY	W	1	1988	0	0	0	0	0	0	0	0	0	0	0
01S/03W-21A	3601046	RAMIREZ, J. J.	W	STOWE	1956	0	0	0	0	0	0	0	0	0	0	0
01S/03W-21A	3601046-	RAMIREZ, J. J.	W	STOWE	2007	0	0	0	0	0	0	0	0	0	0	0
01S/03W-21E	3601102	MAJESTIC MANAGEMENT	W	2 / MASCART	2007	0	0	0	0	0	0	0	0	0	0	0
01S/03W-21E	3601751	RIVENDELL LAND COMPANY	W	ALABAMA/CHRISTINA		0	0	0	0	0	0	0	0	0	0	0
01S/03W-21G01S	3600526	REDLANDS FARMING	W	LUGONIA	1981	0	0	0	0	0	0	0	0	0	0	0
01S/03W-21H01S	3601298	REDLANDS, CITY OF	W	32		0	0	0	0	0	0	0	0	0	0	0
01S/03W-21H06S	3602031	REDLANDS, CITY OF	W	30-A		207	257	360	360	616	304	349				
01S/03W-21H07S	3602036	REDLANDS, CITY OF	W	31-A		0	0	0	0	0	0	106	21			
01S/03W-21K01S	3600510	REDLANDS, CITY OF	W	LUGO #1	2003	0	0	0	0	0	0	0	0	0	0	0
01S/03W-21M01S	3600124	NICKERSON WATER COMPANY NO 2	W	2	1981	0	0	0	0	0	0	0	0	0	0	0
01S/03W-21M02S	0000165	SANDY'S RESTAURANT	W		2005	0	0	0	0	0	0	0	0	0	0	0
01S/03W-21P01S	3600107	B M I FUNDS	W	COLTON 1	1966	0	0	0	0	0	0	0	0	0	0	0
01S/03W-21R01S	3600001-	SMITH TRACT WELL COMPANY	W		1972	0	0	0	0	0	0	0	0	0	0	0
01S/03W-21R02S	3600001	SMITH TRACT WELL COMPANY	W	11	1978	0	0	0	0	0	0	0	0	0	0	0
01S/03W-22A01S	3602106	REDLANDS, CITY OF	W		1968	0	0	0	0	0	0	0	0	0	0	0
01S/03W-22A02S	3602032	REDLANDS, CITY OF	W	35		0	0	0	0	0	0	0	0	0	0	0
01S/03W-22F	3601099	PENN WELL COMPANY	W	1	1957	0	0	0	0	0	0	0	0	0	0	0
01S/03W-22F	3601405	PENN WELL COMPANY	W	2	1981	0	0	0	0	0	0	0	0	0	0	0
01S/03W-23A03S	3601585	BEAR VALLEY MUTUAL WATER COMPANY	W	SBDNO AV 1 NELSON		0	0	0	0	0	0	0	0	0	0	0
01S/03W-23A03S	3601647	JUDSON MUTUAL WATER COMPANY	W	1	1982	0	0	0	0	0	0	0	0	0	0	0
01S/03W-23A05S	3600019	REDLANDS, CITY OF	W	GR REES 1		0	258	1,114	1,114	1,759	1,633	953				
01S/03W-23F	3600933	NORTHSIDE WATER COMPANY	W	1	1978	0	0	0	0	0	0	0	0	0	0	0
01S/03W-24A01S	3600748	REDLANDS, CITY OF	W	MENTONE ACRES #1-OL		0	973	91	91	73	75	242				
01S/03W-24C	3600023	BEAR VALLEY MUTUAL WATER COMPANY	W	JUDSON1		0	0	0	0	0	0	0	0	0	0	0
01S/03W-24Q	0000156	WESTERN FRUIT GROWERS	W		1979	0	0	0	0	0	0	0	0	0	0	0
01S/03W-25N01S	3600049	REDLANDS COUNTRY CLUB	W	MORRISON	1978	0	0	0	0	0	0	0	0	0	0	0
01S/03W-25N02S	3600049-	REDLANDS COUNTRY CLUB	W	MORRISON/HOBBS	2006	0	0	0	0	0	0	0	0	0	0	0
01S/03W-26C01S	3602211	REDLANDS, CITY OF	W	37 SYLVAN PARK		0	0	0	0	0	0	0	0	0	0	0
01S/03W-27E02S	3601300	REDLANDS, CITY OF	W	40	1988	0	0	0	0	0	0	0	0	0	0	0
01S/03W-28B01S	3600608	EAST BARTON WATER COMPANY	W	BARTON	1971	0	0	0	0	0	0	0	0	0	0	0

**WESTERN - SAN BERNARDINO WATERMASTER
VERIFIED PRODUCTION DATA - NON PLAINTIFFS
CROSS INDEX BY STATE WELL NUMBER
SAN BERNARDINO BASIN**

STATE WELL NUMBER	RECRDTN NUMBER	OWNER	WELL TYPE	LOCAL DESIGNATION	YEAR CLOSED	-----CALENDAR YEAR EXTRACTIONS-----										
						2008	2009	2010	2011	2012	AVG					
01S/03W-28C01S	3600075	GRANT WATER COMPANY	W	GRANT	1991	0	0	0	0	0	0	0	0	0	0	
01S/03W-28D01S	3601092	KANSAS STREET MUTUAL WATER COMPANY	W	KANSAS		0	0	0	0	0	0	0	0	0	0	
01S/03W-28H01S	3601301	REDLANDS, CITY OF	W	41		465	448	404	443	366	425					
01S/03W-28J01S	3600085	REDLANDS, CITY OF	W	NY ST 1	1966	0	0	0	0	0	0	0	0	0	0	
01S/03W-28K01S	3602346	REDLANDS, CITY OF	W	NEW YORK ST. WELL		1,217	1,009	1,000	945	843	1,003					
01S/03W-28L	3600651	MOUNTAIN VIEW POWER CO.	W		1977	0	0	0	0	0	0	0	0	0	0	
01S/03W-28M	3601649	HOOVER WELL	W	HOOVER	1978	0	0	0	0	0	0	0	0	0	0	
01S/03W-28N	3601649	RAMIREZ, J. J.	W	HOOVER		0	0	0	0	0	0	0	0	0	0	
01S/03W-29A01S	3600766	ELTINGE & GRAZIADIO	W	COLTAMA	1971	0	0	0	0	0	0	0	0	0	0	
01S/03W-29B	3600708	LA ROSSE, CHARLES H	W	GOODWIN	1966	0	0	0	0	0	0	0	0	0	0	
01S/03W-29B01S	3601932	IOWA STREET WELL	W		1974	0	0	0	0	0	0	0	0	0	0	
01S/03W-29D	3601280	YAHIKU, PAUL	W	SOUTH 1	1981	0	0	0	0	0	0	0	0	0	0	
01S/03W-29E	3601753	RANCHO CITRUS AMIGOS	W	PARK AVE 1	1971	0	0	0	0	0	0	0	0	0	0	
01S/03W-29H	3600817	WOEHR MUTUAL WATER COMPANY	W		1991	0	0	0	0	0	0	0	0	0	0	
01S/03W-29J01S	3600415	PHAROAH-POWELL WATER CO	W			199	241	182	169	218	202					
01S/03W-29K	3600493	MONTE LLC	W	2 NEW WELL	2006	0	0	0	0	0	0	0	0	0	0	
01S/03W-29L	3600494	MONTE LLC	W	1 OLD WELL		65	59	53	63	65	61					
01S/03W-29Q01S	3603655	REDLANDS, CITY OF	W	#38		1,701	1,646	1,897	2,037	1,809	1,818					
01S/03W-29Q02S	3603760	REDLANDS, CITY OF	W	WELL 39		302	1,086	935	999	1,082	881					
01S/03W-30D	3601637	REDLANDS, CITY OF	W		1977	0	0	0	0	0	0	0	0	0	0	
01S/03W-30K	3601131	FRINK RANCH	W	1	1958	0	0	0	0	0	0	0	0	0	0	
01S/03W-30L	3601728	RAMIREZ, J. J.	W	FRINK'S #1		0	0	0	0	0	0	0	0	0	0	
01S/03W-30M	3601910	LOMA LINDA UNIVERSITY	W	PUFFER	1975	0	0	0	0	0	0	0	0	0	0	
01S/03W-30Q	3600468	SAN BERNARDINO COUNTY - FACILITY MANAGE	W	BAHR 1	1971	0	0	0	0	0	0	0	0	0	0	
01S/03W-31A	0000015	BREAK, ALLEN ESTATE	W			1	1	1	1	1	1					
01S/03W-31A02S	3600053	REDLANDS, CITY OF	W	1, BRYN MAWR		0	0	0	0	0	0	0	0	0	0	
01S/03W-31A03S	3600054	REDLANDS, CITY OF	W	2, BRYN MAWR MUTUAL	1964	0	0	0	0	0	0	0	0	0	0	
01S/03W-31A06S	3600055	REDLANDS, CITY OF	W	3, BRYN MAWR MUTUAL	1975	0	0	0	0	0	0	0	0	0	0	
01S/03W-31B01S	3602109	REDLANDS, CITY OF	W	4, BRYN MAWR		0	0	0	0	0	0	0	0	0	0	
01S/03W-31D	0000128	STEWART, WILLARD	W		1978	0	0	0	0	0	0	0	0	0	0	
01S/03W-32D	3601130	SAN BERNARDINO COUNTY FLOOD CONTROL	W	NICK'S WELL		149	190	189	0	0	106					
01S/03W-32G	0000178	KUHN, RICHARD J.	W			0	0	0	0	0	0	0	0	0	0	
01S/03W-32G01S	3600160	CANYON RANCH	W	GUNTER		0	0	0	0	0	0	0	0	0	0	
01S/03W-32G03S	3600523	REDLANDS FARMING	W	HNTSCHKE	1980	0	0	0	0	0	0	0	0	0	0	
01S/03W-32J	0000070	HORTON,	W	LA PAPER BOX		248	315	267	222	356	282					
01S/03W-32J02S	3602065	REDLANDS, CITY OF	W	LEE WELL	1978	0	0	0	0	0	0	0	0	0	0	
01S/03W-32J02S	3602065-	REDLANDS, CITY OF	W	LEE WELL		0	0	0	0	0	0	0	0	0	0	

**WESTERN - SAN BERNARDINO WATERMASTER
VERIFIED PRODUCTION DATA - NON PLAINTIFFS
CROSS INDEX BY STATE WELL NUMBER
SAN BERNARDINO BASIN**

STATE WELL NUMBER	RECRDTN NUMBER	OWNER	WELL TYPE	LOCAL DESIGNATION	YEAR CLOSED	-----CALENDAR YEAR EXTRACTIONS-----										
						1980	1974	1989	1979	2008	2009	2010	2011	2012	AVG	
01S/03W-32K	3601173	SOJKA, DONALD R.	W		1980	0	0	0	0	0	0	0	0	0	0	0
01S/03W-33C01S	3602119	LAKESIDE AVENUE MUTUAL WELL COMPANY	W	REDLANDS	1974	0	0	0	0	0	0	0	0	0	0	0
01S/03W-33D	3600036	BROOKSIDE DAIRY INC	W	1	1989	0	0	0	0	0	0	0	0	0	0	0
01S/03W-33D01S	3602917	BROOKSIDE PLAZA	W	STATER BROS PLAZA		14	14	13	13	7	7	13	13	12		
01S/03W-35E	3601289	REDLANDS, CITY OF	W	4R	1979	0	0	0	0	0	0	0	0	0	0	0
01S/03W-35G07S	3601292	REDLANDS, CITY OF	W	11		69	75	94	108	136	136	96				
01S/03W-35G08S	3601291	REDLANDS, CITY OF	W	10		0	0	0	0	0	0	0	0	0	0	0
01S/03W-35G09S	3601294	REDLANDS, CITY OF	W	13		0	0	0	0	0	0	0	0	0	0	0
01S/03W-35G11S	3601297	REDLANDS, CITY OF	W	17	2010	0	0	0	0	0	0	0	0	0	0	0
01S/03W-35H02S	3601293	REDLANDS, CITY OF	W	12	2006	0	0	0	0	0	0	0	0	0	0	0
01S/03W-35H03S	3601296	REDLANDS, CITY OF	W	16		694	1,141	473	22	22	0	466				
01S/03W-35H04S	3601295	REDLANDS, CITY OF	W	14		0	0	0	0	0	0	0	0	0	0	0
01S/03W-35H08S	3600005	REDLANDS, CITY OF	W	LUETCKE	1981	0	0	0	0	0	0	0	0	0	0	0
01S/04W-01A	3602069	ARROYO VERDE MUTUAL WATER COMPANY	W		2005	0	0	0	0	0	0	0	0	0	0	0
01S/04W-01A02S	3602068	ARROYO VERDE MUTUAL WATER COMPANY	W		2005	0	0	0	0	0	0	0	0	0	0	0
01S/04W-01B04S	3601657	EAST VALLEY WATER DISTRICT	W	PL 7	2000	0	0	0	0	0	0	0	0	0	0	0
01S/04W-01D	0000051	EAST VALLEY WATER DISTRICT	W	PLANT NO 96	2005	0	0	0	0	0	0	0	0	0	0	0
01S/04W-01E02S	3601668	EAST VALLEY WATER DISTRICT	W	PL 22	2000	0	0	0	0	0	0	0	0	0	0	0
01S/04W-01F02S	3600926	EAST VALLEY WATER DISTRICT	W	PL 115	2003	0	0	0	0	0	0	0	0	0	0	0
01S/04W-01J08S	3601661	EAST VALLEY WATER DISTRICT	W	PL 10	2003	0	0	0	0	0	0	0	0	0	0	0
01S/04W-01K04S	3601665	EAST VALLEY WATER DISTRICT	W	PL 14		0	0	0	0	0	0	0	0	0	0	0
01S/04W-01P01S	3602130	EASTWOOD FARMS COMMUNITY WATER USERS	W	1	2002	0	0	0	0	0	0	0	0	0	0	0
01S/04W-01P02S	3602131	EASTWOOD FARMS COMMUNITY WATER USERS	W	2	2002	0	0	0	0	0	0	0	0	0	0	0
01S/04W-01Q01S	3600925	EAST VALLEY WATER DISTRICT	W	PL 100	2003	0	0	0	0	0	0	0	0	0	0	0
01S/04W-01Q08S	3602034	EAST VALLEY WATER DISTRICT	W	PL 12A		210	2	1	1	1	1	43				
01S/04W-02A	3600183	EAST VALLEY WATER DISTRICT	W	PL 60	2003	0	0	0	0	0	0	0	0	0	0	0
01S/04W-02A	3692174	EAST VALLEY WATER DISTRICT	W	PL 105	1984	0	0	0	0	0	0	0	0	0	0	0
01S/04W-02A05S	3602174	EAST VALLEY WATER DISTRICT	W	PL 105 / MYERS	2000	0	0	0	0	0	0	0	0	0	0	0
01S/04W-02B	3602066	SAN BERNARDINO, CITY OF	W	1, VAN LOON/BELVAN		0	0	0	0	0	0	0	0	0	0	0
01S/04W-02D	3600399	VICTORIA GUERNSEY	W	1	1968	0	0	0	0	0	0	0	0	0	0	0
01S/04W-02J	0000012	BERMAN, BUD	W		2006	0	0	0	0	0	0	0	0	0	0	0
01S/04W-02K	0000011	BERMAN, BUD	W	OLD WELL	1962	0	0	0	0	0	0	0	0	0	0	0
01S/04W-02K	3602007	BERMAN, BUD	W	2	2009	5	0	0	0	0	0	0	0	0	0	1
01S/04W-02K01S	3600730	SAN BERNARDINO, CITY OF	W	ANTIL #3	1981	0	0	0	0	0	0	0	0	0	0	0
01S/04W-02K02S	3600731	SAN BERNARDINO, CITY OF	W	ANTIL #5		0	0	0	0	0	0	0	0	0	0	0
01S/04W-02K03S	3600734	SAN BERNARDINO, CITY OF	W	ANTIL #4		0	0	0	0	0	0	0	0	0	0	0
01S/04W-02K04S	3600733	SAN BERNARDINO, CITY OF	W	ANTIL #1	1981	0	0	0	0	0	0	0	0	0	0	0

**WESTERN - SAN BERNARDINO WATERMASTER
 VERIFIED PRODUCTION DATA - NON PLAINTIFFS
 CROSS INDEX BY STATE WELL NUMBER
 SAN BERNARDINO BASIN**

STATE WELL NUMBER	RECRDTN NUMBER	OWNER	WELL TYPE	LOCAL DESIGNATION	YEAR CLOSED	-----CALENDAR YEAR EXTRACTIONS-----										
						2008	2009	2010	2011	2012	AVG					
01S/04W-02K05S	3600732	SAN BERNARDINO, CITY OF	W	ANTIL #2	1978	0	0	0	0	0	0	0	0	0	0	
01S/04W-02K08S	3602422	SAN BERNARDINO, CITY OF	W	ANTIL 6		0	81	5	27	0	0	0	0	0	23	
01S/04W-02L	0000042	EAST VALLEY WATER DISTRICT	W	PLANT NO 75	2005	0	0	0	0	0	0	0	0	0	0	
01S/04W-02N01S	3601664	EAST VALLEY WATER DISTRICT	W	PL 13	2003	0	0	0	0	0	0	0	0	0	0	
01S/04W-02Q04S	3601663	EAST VALLEY WATER DISTRICT	W	PL 12		0	0	0	0	0	0	0	0	0	0	
01S/04W-02Q05S	3601662	EAST VALLEY WATER DISTRICT	W	PL 11	2000	0	0	0	0	0	0	0	0	0	0	
01S/04W-02Q10S	3602563	EAST VALLEY WATER DISTRICT	W	PL 11A		1,546	1,911	1,629	1,288	1,028	1,480					
01S/04W-02R	3601582	EAST VALLEY WATER DISTRICT	W	PL 119	2003	0	0	0	0	0	0	0	0	0	0	
01S/04W-03A04S	3603692	SAN BERNARDINO, CITY OF	W	EPA #5		2,379	2,430	1,227	204	1,083	1,465					
01S/04W-03B03S	3603691	SAN BERNARDINO, CITY OF	W	EPA #4		2,107	2,201	1,918	2,011	1,874	2,022					
01S/04W-03C03S	3603689	SAN BERNARDINO, CITY OF	W	EPA #2		2,165	2,260	2,243	2,337	2,680	2,337					
01S/04W-03C04S	3603690	SAN BERNARDINO, CITY OF	W	EPA #3		3,412	3,198	3,069	3,112	2,563	3,071					
01S/04W-03D01S	3600722	SAN BERNARDINO, CITY OF	W	11TH & E ST (ACACIA)	1968	0	0	0	0	0	0	0	0	0	0	
01S/04W-03D04S	3603688	SAN BERNARDINO, CITY OF	W	EPA #1		1,986	1,526	2,003	2,328	2,269	2,022					
01S/04W-03J05S	3602265	SAN BERNARDINO, CITY OF	W	7TH ST.		140	226	79	165	216	165					
01S/04W-04B04S	3603207	SAN BERNARDINO, CITY OF	W	10TH & J ST		1,620	2,075	1,797	2,507	1,723	1,944					
01S/04W-04D02S	3603206	SAN BERNARDINO, CITY OF	W	OLIVE/GARNER		1,306	1,194	1,225	1,739	1,113	1,315					
01S/04W-04E01S	3603141	SAN BERNARDINO VALLEY M.W.D.	W	9TH ST.	2011	0	0	0	0	0	0	0	0	0	0	
01S/04W-04F02S	3603174	SAN BERNARDINO VALLEY M.W.D.	W	PERRIS ST		0	0	0	0	0	0	0	0	0	0	
01S/04W-05E05S	3601848	WEST VALLEY WATER DIST	W	#15 9TH & PENNSYLVAN		764	801	156	969	1,012	740					
01S/04W-05F01S	3603965	SAN BERNARDINO VALLEY M.W.D.	W	9TH STREET SOUTH						1,350	270					
01S/04W-05F02S	3603964	SAN BERNARDINO VALLEY M.W.D.	W	9TH STREET NORTH						1,565	313					
01S/04W-05M	3601309	TRI-CITY CONCRETE	W	PLANT	1979	0	0	0	0	0	0	0	0	0	0	
01S/04W-05R	3601252	COLTON, CITY OF	W	6	1972	0	0	0	0	0	0	0	0	0	0	
01S/04W-06B01S	3603030	RIALTO, CITY OF	W	CITY #5		0	0	0	0	0	0	0	0	0	0	
01S/04W-06C04S	3601929	RIALTO, CITY OF	W	CITY #6		0	0	0	0	0	0	0	0	0	0	
01S/04W-06H02S	3601003	WEST VALLEY WATER DIST	W	#13 / RAYNOR 4	1977	0	0	0	0	0	0	0	0	0	0	
01S/04W-06H03S	3602766	WEST VALLEY WATER DIST	W	#30 WASHINGTON/BSLIN		930	459	616	366	669	608					
01S/04W-06H04S	3603538	RIALTO, CITY OF	W	CITY #4A		2,427	2,605	1,980	870	932	1,763					
01S/04W-06J01S	3600999	WEST VALLEY WATER DIST	W	DIXON 1	1973	0	0	0	0	0	0	0	0	0	0	
01S/04W-06J02S	3601000	WEST VALLEY WATER DIST	W	#12 / DIXON 2	1967	0	0	0	0	0	0	0	0	0	0	
01S/04W-07D	0000086	INLAND VALLEY DEVELOPMENT AGENCY	W	LOCAL NO. 2	1997	0	0	0	0	0	0	0	0	0	0	
01S/04W-08C02S	3601262	COLTON, CITY OF	W	BARNHL 18	1980	0	0	0	0	0	0	0	0	0	0	
01S/04W-08C04S	3602405	COLTON, CITY OF	W	19		997	1,103	554	897	884	887					
01S/04W-08F	3600179	ATCHISON TOPEKA & SANTA FE RAILWAY	W	4	1980	0	0	0	0	0	0	0	0	0	0	
01S/04W-08F01S	3601260	COLTON, CITY OF	W	16		449	0	287	656	836	446					
01S/04W-08F02S	3600178	ATCHISON TOPEKA & SANTA FE RAILWAY	W	3	1980	0	0	0	0	0	0	0	0	0	0	

**WESTERN - SAN BERNARDINO WATERMASTER
VERIFIED PRODUCTION DATA - NON PLAINTIFFS
CROSS INDEX BY STATE WELL NUMBER
SAN BERNARDINO BASIN**

STATE WELL NUMBER	RECRD TN NUMBER	OWNER	WELL TYPE	LOCAL DESIGNATION	YEAR CLOSED	-----CALENDAR YEAR EXTRACTIIONS-----										
						1978	2008	2009	2010	2011	2012	AVG				
01S/04W-08F06S	3601684	TERRACE WATER COMPANY	W	LARGE 1	1978	0	0	0	0	0	0	0	0	0	0	0
01S/04W-08F07S	3601257	COLTON, CITY OF	W	13		804	677	781	876	656	759					
01S/04W-08F08S	3601254	COLTON, CITY OF	W	8		0	0	0	0	0	0	0	0	0	0	0
01S/04W-08F10S	3601250	COLTON, CITY OF	W	4	1982	0	0	0	0	0	0	0	0	0	0	0
01S/04W-08F12S	3601684-	TERRACE WATER COMPANY	W	#1 SMALL, 50 HP SUB		255	399	268	392	252	313					
01S/04W-08F14S	3601685	TERRACE WATER COMPANY	W	SMALL 2	1962	0	0	0	0	0	0	0	0	0	0	0
01S/04W-08F14S	3601686	TERRACE WATER COMPANY	W	#2 LARGE WELL, 100HP		558	389	433	314	499	439					
01S/04W-08F15S	3602793	COLTON, CITY OF	W	WELL 21		1,797	1,816	1,032	1,438	1,879	1,592					
01S/04W-08F17S	3603915	COLTON, CITY OF	W	#28		621	396	459	0	298	355					
01S/04W-08J02S	3603704	COLTON, CITY OF	W	26		551	609	468	735	648	602					
01S/04W-08J03S	3603914	COLTON, CITY OF	W	#27		1,698	1,733	1,159	181	1,021	1,158					
01S/04W-08Q01S	3601253	COLTON, CITY OF	W	7		0	0	0	0	0	0	0	0	0	0	0
01S/04W-08R	3601012	MOUNTAIN VIEW POWER CO.	W	STM PL 1	1977	0	0	0	0	0	0	0	0	0	0	0
01S/04W-08R	3601013	MOUNTAIN VIEW POWER CO.	W	STM PL 2	1977	0	0	0	0	0	0	0	0	0	0	0
01S/04W-08R	3601258	COLTON, CITY OF	W	14	2002	0	0	0	0	0	0	0	0	0	0	0
01S/04W-08R05S	3601251	COLTON, CITY OF	W	5	2002	0	0	0	0	0	0	0	0	0	0	0
01S/04W-08R07S	3602498	COLTON, CITY OF	W	NO 6B	2002	0	0	0	0	0	0	0	0	0	0	0
01S/04W-09B01S	3600645	HOLMES ICE & COLD STORAGE	W		1960	0	0	0	0	0	0	0	0	0	0	0
01S/04W-09B03S	3600644	HOLMES ICE & COLD STORAGE	W	2	2003	0	0	0	0	0	0	0	0	0	0	0
01S/04W-09J01S	3600736	SAN BERNARDINO, CITY OF	W	SOUTH G ST	1978	0	0	0	0	0	0	0	0	0	0	0
01S/04W-09N	3601256	COLTON, CITY OF	W	PLUNGE12	1980	0	0	0	0	0	0	0	0	0	0	0
01S/04W-09P01S	3600735	SAN BERNARDINO, CITY OF	W	BIRCH ST.	1981	0	0	0	0	0	0	0	0	0	0	0
01S/04W-10D	3601626	SAN BERNARDINO, CITY OF	W	CITYLOTS	1969	0	0	0	0	0	0	0	0	0	0	0
01S/04W-10F01S	3600723	SAN BERNARDINO, CITY OF	W	HANFORD 1	1968	0	0	0	0	0	0	0	0	0	0	0
01S/04W-10F01S	3690723	SOUTHERN CALIFORNIA EDISON	W	HANFORD1	1981	0	0	0	0	0	0	0	0	0	0	0
01S/04W-10F05S	3600724	SAN BERNARDINO, CITY OF	W	HANFORD 2	1968	0	0	0	0	0	0	0	0	0	0	0
01S/04W-10N06S	3600737	SAN BERNARDINO, CITY OF	W	MILL & D		429	377	397	502	398	421					
01S/04W-11F	0000021	DONGLO DAIRY	W		1947	0	0	0	0	0	0	0	0	0	0	0
01S/04W-11F	0000075	KRANTZ DAIRY	W		2007	0	0	0	0	0	0	0	0	0	0	0
01S/04W-11G	0000065	HAZAS,	W		1999	0	0	0	0	0	0	0	0	0	0	0
01S/04W-11G	0000159	WILLIAMS DAIRY	W		2005	0	0	0	0	0	0	0	0	0	0	0
01S/04W-11M	0000005	BALCOM,	W		1999	0	0	0	0	0	0	0	0	0	0	0
01S/04W-11Q01S	3600222	SAN BERNARDINO, CITY OF	W	MCFARLAND JOHNSON	2000	0	0	0	0	0	0	0	0	0	0	0
01S/04W-12B05S	3601676	EAST VALLEY WATER DISTRICT	W	PL 28	2000	0	0	0	0	0	0	0	0	0	0	0
01S/04W-12B07S	3602564	EAST VALLEY WATER DISTRICT	W	PL 28A		2,560	2,491	2,429	1,623	1,445	2,110					
01S/04W-12C	0000087	INLAND VALLEY DEVELOPMENT AGENCY	W	LOCAL NO. 3	1997	0	0	0	0	0	0	0	0	0	0	0
01S/04W-12C01S	3603647	INLAND VALLEY DEVELOPMENT AGENCY	W	NORTON #3		0	0	0	0	0	0	0	0	0	0	0

**WESTERN - SAN BERNARDINO WATERMASTER
VERIFIED PRODUCTION DATA - NON PLAINTIFFS
CROSS INDEX BY STATE WELL NUMBER
SAN BERNARDINO BASIN**

STATE WELL NUMBER	RECRD TN NUMBER	OWNER	WELL TYPE	LOCAL DESIGNATION	YEAR CLOSED	-----CALENDAR YEAR EXTRACTIONS-----										
						2008	2009	2010	2011	2012	AVG					
01S/04W-12D	0000088	INLAND VALLEY DEVELOPMENT AGENCY	W	LOCAL NO. 4	2005	0	0	0	0	0	0	0	0	0	0	
01S/04W-12D	3600973	CARDIFF FARMS MUTUAL WATER COMPANY	W	1	1991	0	0	0	0	0	0	0	0	0	0	
01S/04W-12D	3601619	CARDIFF FARMS MUTUAL WATER COMPANY	W	2	1991	0	0	0	0	0	0	0	0	0	0	
01S/04W-12F	0000089	INLAND VALLEY DEVELOPMENT AGENCY	W	LOCAL NO. 5	1997	0	0	0	0	0	0	0	0	0	0	
01S/04W-12F	3603648	INLAND VALLEY DEVELOPMENT AGENCY	W	NORTON #5		0	0	0	0	0	0	0	0	0	0	
01S/04W-12G	0000092	INLAND VALLEY DEVELOPMENT AGENCY	W	LOCAL NO. 44	2005	0	0	0	0	0	0	0	0	0	0	
01S/04W-12N	3600291	MAYBELL, N O	W		1965	0	0	0	0	0	0	0	0	0	0	
01S/04W-12Q	0000091	INLAND VALLEY DEVELOPMENT AGENCY	W	NO NO. WELL	2005	0	0	0	0	0	0	0	0	0	0	
01S/04W-13E	0000058	GOLCONDA WATER COMPANY	W		1969	0	0	0	0	0	0	0	0	0	0	
01S/04W-13R01S	3602112	VICTORIA FARMS MUTUAL WATER CO	W		1966	0	0	0	0	0	0	0	0	0	0	
01S/04W-13R01S	3602714	VICTORIA FARMS MUTUAL WATER CO	W	NO 1	1999	0	0	0	0	0	0	0	0	0	0	
01S/04W-13R03S	3602247	VICTORIA FARMS MUTUAL WATER CO	W	2	1981	0	0	0	0	0	0	0	0	0	0	
01S/04W-13R04S	3602574	VICTORIA FARMS MUTUAL WATER CO	W	NO. 3	1999	0	0	0	0	0	0	0	0	0	0	
01S/04W-14A	0000001	SAN BERNARDINO COUNTY - FACILITY MANAGE	W	AEROSPACE	2005	0	0	0	0	0	0	0	0	0	0	
01S/04W-14A	0000120	SANTINI,	W		2007	0	0	0	0	0	0	0	0	0	0	
01S/04W-14A	3602128	SAN BERNARDINO, CITY OF	W	GIFFORD PK/ #1	2007	0	0	0	0	0	0	0	0	0	0	
01S/04W-14B03S	3602252	SAN BERNARDINO, CITY OF	W	2	1977	0	0	0	0	0	0	0	0	0	0	
01S/04W-14E	0000068	HOLDEN MUTUAL WATER COMPANY	W		1999	0	0	0	0	0	0	0	0	0	0	
01S/04W-14F	0000069	HOLDEN MUTUAL WATER COMPANY	W	HOLDEN AVE.	1999	0	0	0	0	0	0	0	0	0	0	
01S/04W-14F	0000181	UNKNOWN	W	FOISTY STREET	2007	0	0	0	0	0	0	0	0	0	0	
01S/04W-14J	3602123	SAN BERNARDINO, CITY OF	W	NORMAN RD		0	0	0	0	0	0	0	0	0	0	
01S/04W-14J	3602124	SAN BERNARDINO, CITY OF	W	CENTRAL AVE	1984	0	0	0	0	0	0	0	0	0	0	
01S/04W-15D	3601924	NATIONAL ORANGE SHOW	W			20	50	1	50	62	37					
01S/04W-15D05S	3602285	SAN BERNARDINO, CITY OF	W	15D5	1979	0	0	0	0	0	0	0	0	0	0	
01S/04W-15G	0000066	HELIPORT	W		2005	0	0	0	0	0	0	0	0	0	0	
01S/04W-15M01S	3600035	SAN BERNARDINO, CITY OF	W		1979	0	0	0	0	0	0	0	0	0	0	
01S/04W-15P05S	3603582	SAN BERNARDINO, CITY OF	W	CHANDLER		800	857	633	754	1,133	835					
01S/04W-15P06S	3603960	SAN BERNARDINO, CITY OF	W	ORANGE SHOW RD/PRO		255	20	1	0	0	55					
01S/04W-15Q	0000142	VALLEY FARMS MUTUAL WATER COMPANY	W	NO 2 WELL	2001	0	0	0	0	0	0	0	0	0	0	
01S/04W-15R	0000141	VALLEY FARMS MUTUAL WATER COMPANY	W	NO 1 WASHTN	2001	0	0	0	0	0	0	0	0	0	0	
01S/04W-16H	3600034	SAN BERNARDINO, CITY OF	W	SMITH 1	1979	0	0	0	0	0	0	0	0	0	0	
01S/04W-21A	0000115	SAN BERNARDINO, CITY OF	W	SEWER PLANT 1	2006	0	0	0	0	0	0	0	0	0	0	
01S/04W-22A	0000123	SIX HOUSES	W		1985	0	0	0	0	0	0	0	0	0	0	
01S/04W-22A01S	3602499	J. G. GOLFING ENTERPRISES	W	PAYNE H 25		206	251	304	196	192	230					
01S/04W-22A01S	3602846	J. G. GOLFING ENTERPRISES	W	THORN 10 & 11		469	319	282	394	439	381					
01S/04W-22B	0000007	BARRIER,	W		2004	0	0	0	0	0	0	0	0	0	0	
01S/04W-22B	0000016	CARPENTER,	W		1971	0	0	0	0	0	0	0	0	0	0	

**WESTERN - SAN BERNARDINO WATERMASTER
VERIFIED PRODUCTION DATA - NON PLAINTIFFS
CROSS INDEX BY STATE WELL NUMBER
SAN BERNARDINO BASIN**

STATE WELL NUMBER	RECRDTN NUMBER	OWNER	WELL TYPE	LOCAL DESIGNATION	YEAR CLOSED	2008	2009	2010	2011	2012	AVG
01S/04W-22C	0000116	SAN BERNARDINO, CITY OF	W	SEWER PLANT 2	2005	0	0	0	0	0	0
01S/04W-22C05S	3603581	SAN BERNARDINO, CITY OF	W	CENTURY		950	830	895	541	355	714
01S/04W-22C06S	3603944	SAN BERNARDINO VALLEY M.W.D.	W	DE-WATERING #1		0	290	0	0	0	58
01S/04W-22F01S	3603945	SAN BERNARDINO VALLEY M.W.D.	W	DE-WATERING #2		0	0	0	0	0	0
01S/04W-22G01S	3601016	MOUNTAIN VIEW POWER CO.	W	THORN 1	1977	0	0	0	0	0	0
01S/04W-22M01S	0000126	SMITH MEAT PACKING PLANT	W		1999	0	0	0	0	0	0
01S/04W-23D	3600030	MEADOWBROOK DAIRY	W	IRRIG 2	2004	0	0	0	0	0	0
01S/04W-23D	3600037	MEADOWBROOK DAIRY	W	DOMESTC 1	2004	0	0	0	0	0	0
01S/04W-23K	3601823	TRI-CITY MUTUAL WATER COMPANY	W		1964	0	0	0	0	0	0
01S/04W-23N	0000133	TRI-CITY MUTUAL WATER COMPANY	W		1971	0	0	0	0	0	0
01S/04W-23N	3601316	SAN BERNARDINO, CITY OF	W	INTERCITY MUTUAL 08		0	0	0	0	0	0
01S/04W-23N04S	3602521	SAN BERNARDINO, CITY OF	W	NO 2	1977	0	0	0	0	0	0
01S/04W-23P	0000072	INTER CITY MUTUAL WATER COMPANY	W		1977	0	0	0	0	0	0
01S/04W-23R03S	3602122	SAN BERNARDINO, CITY OF	W	ROSEWOOD	1966	0	0	0	0	0	0
01S/04W-24A01S	3602759	LOMA LINDA, CITY OF	W	MT VIEW 1	1999	0	0	0	0	0	0
01S/04W-24A05S	3603719	LOMA LINDA, CITY OF	W	MTN. VIEW #3		1,732	2,265	2,200	442	795	1,487
01S/04W-24B01S	3602760	LOMA LINDA, CITY OF	W	MT VIEW 2	2000	0	0	0	0	0	0
01S/04W-24B03S	3603776	LOMA LINDA, CITY OF	W	MTN. VIEW #5		592	44	138	0	0	155
01S/04W-24B04S	3603956	LOMA LINDA, CITY OF	W	MTN. VIEW #6					740	1,537	455
01S/04W-24B05S	3603955	LOMA LINDA, CITY OF	W	RICHARSON #5					1,252	1,305	511
01S/04W-24C01S	3603057	LOMA LINDA, CITY OF	W	RICHARDSON #1		422	323	56	0	0	160
01S/04W-24C02S	3603058	LOMA LINDA, CITY OF	W	RICHARDSON # 2	2001	0	0	0	0	0	0
01S/04W-24F	3602126	SAN BERNARDINO, CITY OF	W	GOULD #2 NEW	2007	0	0	0	0	0	0
01S/04W-24F04S	3602125	SAN BERNARDINO, CITY OF	W	GOULD #1 OLD	2007	0	0	0	0	0	0
01S/04W-24F11S	3603720	LOMA LINDA, CITY OF	W	RICHARDSON #4		464	446	51	0	0	192
01S/04W-24J	0000027	TEXACO GAS STATION	W		1984	0	0	0	0	0	0
01S/04W-24J	0000113	RIVAS,	W		1987	0	0	0	0	0	0
01S/04W-24J	0000143	VANLEUVEN, CLARENCE	W		1980	0	0	0	0	0	0
01S/04W-24J	0000144	VICTORIA SEVENTH DAY ADVENTIST	W			10	10	10	10	10	10
01S/04W-24J	0000145	MT. VIEW CHILD CARE CENTER	W		2007	0	0	0	0	0	0
01S/04W-24J	3600016	RIVAS, RAMON	W	REES 4	1981	0	0	0	0	0	0
01S/04W-24K	0000084	MOORE, R. H.	W		2007	0	0	0	0	0	0
01S/04W-24K01S	3601299	REDLANDS, CITY OF	W	34		0	0	0	0	0	0
01S/04W-24L07S	3603927	LOMA LINDA, CITY OF	W	RICHARDSON #6		0	0	1,372	1,989	1,188	910
01S/04W-24N	3602013	LOMA LINDA UNIVERSITY	W	7	1967	0	0	0	0	0	0
01S/04W-24P	3602060	SAN BERNARDINO, CITY OF	W	JOHANSSON, RUNE	1974	0	0	0	0	0	0
01S/04W-24P04S	3603523	LOMA LINDA, CITY OF	W	RICHARDSON #3		1,503	1,546	1,046	978	951	1,205

**WESTERN - SAN BERNARDINO WATERMASTER
 VERIFIED PRODUCTION DATA - NON PLAINTIFFS
 CROSS INDEX BY STATE WELL NUMBER
 SAN BERNARDINO BASIN**

STATE WELL NUMBER	RECRDTN NUMBER	OWNER	WELL TYPE	LOCAL DESIGNATION	YEAR CLOSED	-----CALENDAR YEAR EXTRACTIONS-----										
						2008	2009	2010	2011	2012	AVG					
01S/04W-24R	3601636	REDLANDS, CITY OF	W	LANGFORD	1973	0	0	0	0	0	0	0	0	0	0	
01S/04W-24R01S	3601989	LOMA LINDA, CITY OF	W	GOLCONDA	1974	0	0	0	0	0	0	0	0	0	0	
01S/04W-24R07S	3602596	LOMA LINDA, CITY OF	W	NEW GOLCONDA	1978	0	0	0	0	0	0	0	0	0	0	
01S/04W-24R08S	3603721	LOMA LINDA, CITY OF	W	MTN. VIEW #4		0	0	0	0	0	0	0	0	0	0	
01S/04W-25B	3602015	LOMA LINDA, CITY OF	W	NIES	1992	0	0	0	0	0	0	0	0	0	0	
01S/04W-25B02S	3602011	LOMA LINDA, CITY OF	W	DART	1990	0	0	0	0	0	0	0	0	0	0	
01S/04W-25C	3601384	LOMA LINDA, CITY OF	W	1	1969	0	0	0	0	0	0	0	0	0	0	
01S/04W-25C	3601388	LOMA LINDA, CITY OF	W	COURT ST	1997	0	0	0	0	0	0	0	0	0	0	
01S/04W-25C	3602057	LOMA LINDA, CITY OF	W	MITTLEID	1979	0	0	0	0	0	0	0	0	0	0	
01S/04W-25C01S	3602012	LOMA LINDA UNIVERSITY	W	6	1984	0	0	0	0	0	0	0	0	0	0	
01S/04W-25D05S	3602249	LOMA LINDA UNIVERSITY	W	ANDERSON	1985	0	0	0	0	0	0	0	0	0	0	
01S/04W-25D06S	3602781	LOMA LINDA UNIVERSITY	W	ANDERSON II		92	89	138	67	64	90					
01S/04W-25D07S	3602855	LOMA LINDA UNIVERSITY	W	ANDERSON III		1,308	1,270	1,155	1,276	1,353	1,272					
01S/04W-25E01S	3602017	LOMA LINDA UNIVERSITY	W	2	1964	0	0	0	0	0	0	0	0	0	0	
01S/04W-25F	3602058	LOMA LINDA, CITY OF	W	CROOKS	1991	0	0	0	0	0	0	0	0	0	0	
01S/04W-25G	3602016	LOMA LINDA, CITY OF	W	ROBINSON	1972	0	0	0	0	0	0	0	0	0	0	
01S/04W-25G01S	3602009	LOMA LINDA UNIVERSITY	W	3	1964	0	0	0	0	0	0	0	0	0	0	
01S/04W-25H02S	3602010	LOMA LINDA, CITY OF	W	VAN LEUVEN	1991	0	0	0	0	0	0	0	0	0	0	
01S/04W-26A	3602008	LOMA LINDA UNIVERSITY	W	1	1980	0	0	0	0	0	0	0	0	0	0	
01S/04W-26F	3601168	UNGER, V. E.	W		1977	0	0	0	0	0	0	0	0	0	0	
01S/04W-26F	3603949	MONTECITO MEMORIAL PARK	W	MONTECITO #2		270	270	223	130	155	177	108				
01S/04W-26F01S	3600119	MONTECITO MEMORIAL PARK	W	1		0	0	0	0	0	0	0	0	0	0	
01S/04W-26J01S	3602014	LOMA LINDA UNIVERSITY	W	8	1974	0	0	0	0	0	0	0	0	0	0	
01S/04W-27H	0000002	AHMANSON RANCH	W		1988	0	0	0	0	0	0	0	0	0	0	
01S/04W-36J	3600052	WILEY, RUTH NORWOOD	W	1	1974	0	0	0	0	0	0	0	0	0	0	
02N/05W-19K01S	3600710	SAN BERNARDINO, CITY OF	W	CAJON CYN		495	255	375	447	220	358					
02N/05W-19Q01S	3600709	SAN BERNARDINO, CITY OF	W	VINCENT	1970	0	0	0	0	0	0	0	0	0	0	
02N/05W-19Q01S	3602426	SAN BERNARDINO, CITY OF	D	VINCENT (CAJON CRK)		498	403	521	724	546	538					
02N/05W-19R04S	3603471	SAN BERNARDINO, CITY OF	W	KENWOOD #1		1,166	1,132	1,423	1,770	1,400	1,378					
02N/05W-19R05S	3603791	SAN BERNARDINO, CITY OF	W	KENWOOD 2		1,850	1,419	1,369	1,608	1,362	1,522					
02N/05W-20H	3602385	DEVORE WATER COMPANY	W	MIDDLEMAN FALLS CK		9	8	8	9	11	9					
02N/05W-21E	3602386	DEVORE WATER COMPANY	W	LETHIN SP		46	31	53	66	50	49					
02N/05W-21G	3602388	DEVORE WATER COMPANY	W	KIMBARK		241	171	292	337	155	239					
02N/05W-22E	3602387	DEVORE WATER COMPANY	D	E KIMBARK		68	48	61	75	35	57					
02N/05W-22N	3602389	DEVORE WATER COMPANY	D	HOPPER	1968	0	0	0	0	0	0	0	0	0	0	
02N/05W-27L	3603698	PAYNE, LARRY	W	OWNERS #1		40	1	1	1	1	1	9				
02N/05W-27L02S	3603699	PAYNE, LARRY	W	OWNERS #2		0	1	1	1	1	1	1	1	1	1	

**WESTERN - SAN BERNARDINO WATERMASTER
 VERIFIED PRODUCTION DATA - NON PLAINTIFFS
 CROSS INDEX BY STATE WELL NUMBER
 SAN BERNARDINO BASIN**

STATE WELL NUMBER	RECRDTN NUMBER	OWNER	WELL TYPE	LOCAL DESIGNATION	YEAR CLOSED	-----CALENDAR YEAR EXTRACTATIONS-----											
						2008	2009	2010	2011	2012	2013	2014	2015	2016	2017	2018	AVG
02N/05W-27L03S	3603700	PAYNE, LARRY	W	OWNERS #3		0	0	0	0	0	0	0	0	0	0	0	0
02N/05W-28B	3602390	DEVORE WATER COMPANY	D	SANTA FE	1968	0	0	0	0	0	0	0	0	0	0	0	0
02N/05W-28C02S	3602383	DEVORE WATER COMPANY	W	2A		118	137	62	71	131	104						
02N/05W-28C03S	3602384	DEVORE WATER COMPANY	W	3		93	111	69	0	121	79						
02N/05W-28D	3602382	DEVORE WATER COMPANY	W	1	1957	0	0	0	0	0	0	0	0	0	0	0	0
02N/05W-28D	3602391	DEVORE WATER COMPANY	D	CASADY	1968	0	0	0	0	0	0	0	0	0	0	0	0
02N/05W-33D01S	3603936	SAN BERNARDINO COUNTY - FACILITY MANAGE	W	GLEN HELEN #5		2	0	290	314	115	144						
02N/05W-33E01S	3602428	DEVORE WATER COMPANY	W	4		31	36	25	22	32	29						
02N/05W-33F	3603934	SAN BERNARDINO COUNTY - FACILITY MANAGE	W	GLEN HELEN 3		265	808	206	34	193	301						
02N/05W-33G01S	3603935	SAN BERNARDINO COUNTY - FACILITY MANAGE	W	GLEN HELEN 4		16	18	274	362	111	156						
02N/05W-33G02S	3603937	SAN BERNARDINO COUNTY - FACILITY MANAGE	W	GLEN HELEN #6		626	354	266	148	447	368						
02N/06W-26L01S	3600590	FONTANA UNION WATER COMPANY	W	MIL NAR 2	1986	0	0	0	0	0	0	0	0	0	0	0	0
02N/06W-26L02S	3600588	FONTANA UNION WATER COMPANY	W	MILLER NARROWS #1	1981	0	0	0	0	0	0	0	0	0	0	0	0
02S/02W-06D	0000020	CRYSTAL SPRINGS	W			1	1	1	1	1	1						
02S/03W-01D01S	3600918	REDLANDS, CITY OF	W	1, REDLANDS HEIGHTS		364	373	321	381	401	368						
02S/03W-03K01S	3602082	REDLANDS, CITY OF	W	36 (CEMETERY)		216	189	180	181	177	189						
02S/03W-05A02S	3601632	DEER PARK LLC	W	CLOCK CYN		0	0	0	0	0	0						
TOTALS FOR 794 WELLS						189,335	169,860	160,639	165,053	175,002	171,978						

SAN BERNARDINO BASIN AREA,
CROSS INDEX BY RECORDATION NUMBER

WESTERN - SAN BERNARDINO WATERMASTER
 VERIFIED PRODUCTION DATA - NON PLAINTIFFS
 CROSS INDEX BY RECORDATION NUMBER
 SAN BERNARDINO BASIN

RECRD TN NUMBER	STATE WELL NUMBER	OWNER	FACILITY MANAGE	WELL TYPE	LOCAL DESIGNATION	YEAR CLOSED	-----CALENDAR YEAR EXTRACTIONS-----										
							2005	2006	2007	2008	2009	2010	2011	2012	AVG		
0000001	01S/04W-14A	SAN BERNARDINO COUNTY	AEROSPACE	W		2005	0	0	0	0	0	0	0	0	0	0	0
0000002	01S/04W-27H	AHMANSON RANCH		W		1988	0	0	0	0	0	0	0	0	0	0	0
0000003	01N/04W-25R	ANDERSON, W.D.		W		1999	0	0	0	0	0	0	0	0	0	0	0
0000004	01N/03W-34H	ARNOLD RANCH		W		1978	0	0	0	0	0	0	0	0	0	0	0
0000005	01S/04W-11M	BALCOM,		W		1999	0	0	0	0	0	0	0	0	0	0	0
0000006	01N/03W-34K	BALDWIN,		W		1978	0	0	0	0	0	0	0	0	0	0	0
0000007	01S/04W-22B	BARRIER,		W		2004	0	0	0	0	0	0	0	0	0	0	0
0000008	01N/03W-31Q	BASELINE LAUNDRY		W		1990	0	0	0	0	0	0	0	0	0	0	0
0000009	01N/04W-14R	BATCHELOR,		W		2012	1	1	1	1	1	1	1	1	1	1	1
0000010	01N/04W-14R	BATCHELOR,		D		2012	1	1	1	1	1	1	1	1	1	1	1
0000011	01S/04W-02K	BERMAN, BUD	OLD WELL	W		1962	0	0	0	0	0	0	0	0	0	0	0
0000012	01S/04W-02J	BERMAN, BUD		W		2006	0	0	0	0	0	0	0	0	0	0	0
0000013	01S/02W-22E	BLISS,		W		1988	0	0	0	0	0	0	0	0	0	0	0
0000014	01N/04W-14J	BOUCHER,		W		2012	1	1	1	1	1	1	1	1	1	1	1
0000015	01S/03W-31A	BREAK, ALLEN ESTATE		W		1971	1	1	1	1	1	1	1	1	1	1	1
0000016	01S/04W-22B	CARPENTER,		W		1978	0	0	0	0	0	0	0	0	0	0	0
0000017	01S/03W-03F	CLIFFSIDE RANCH		W		1978	0	0	0	0	0	0	0	0	0	0	0
0000018	01N/03W-27R	COOK CANYON		D		2005	0	0	0	0	0	0	0	0	0	0	0
0000020	02S/02W-06D	CRYSTAL SPRINGS		W		1947	1	1	1	1	1	1	1	1	1	1	1
0000021	01S/04W-11F	DONGLO DAIRY		W		1973	0	0	0	0	0	0	0	0	0	0	0
0000022	01S/03W-17R	DANIELS, HAROLD	RANCH	W		1973	0	0	0	0	0	0	0	0	0	0	0
0000023	01S/03W-17C03S	DANIELS, HAROLD		W		2005	0	0	0	0	0	0	0	0	0	0	0
0000025	01N/04W-24C	DILLSON MUTUAL WATER COMPANY	DOMESTIC WELL	W		1969	0	0	0	0	0	0	0	0	0	0	0
0000026	01N/04W-13P	DILLSON MUTUAL WATER COMPANY	DILLSON AVE	W		1969	0	0	0	0	0	0	0	0	0	0	0
0000027	01S/04W-24J	TEXACO GAS STATION	HARRISON CYN	W		1984	0	0	0	0	0	0	0	0	0	0	0
0000028	01S/02W-06Q	EAST HIGHLAND RANCH		D		1980	0	0	0	0	0	0	0	0	0	0	0
0000029	01N/03W-35B	EAST HIGHLANDS ORANGE COMPANY	TUNNEL DIVERSION	D		1980	0	0	0	0	0	0	0	0	0	0	0
0000030	01N/03W-30C	EAST VALLEY WATER DISTRICT	BOX SPRING	D		1958	0	0	0	0	0	0	0	0	0	0	0
0000032	01S/03W-04P	EAST VALLEY WATER DISTRICT	PLANT NO 36	W		2005	0	0	0	0	0	0	0	0	0	0	0
0000033	01S/03W-05R	EAST VALLEY WATER DISTRICT	PLANT NO 43	W		2005	0	0	0	0	0	0	0	0	0	0	0
0000034	01N/03W-31A	EAST VALLEY WATER DISTRICT	PLANT NO 44	W		2005	0	0	0	0	0	0	0	0	0	0	0
0000035	01N/03W-05Q	EAST VALLEY WATER DISTRICT	PLANT NO 45	W		2005	0	0	0	0	0	0	0	0	0	0	0
0000036	01N/04W-36H	EAST VALLEY WATER DISTRICT	PLANT NO 46	W		2005	0	0	0	0	0	0	0	0	0	0	0
0000037	01S/03W-06Q	EAST VALLEY WATER DISTRICT	PLANT NO 52	W		2005	0	0	0	0	0	0	0	0	0	0	0
0000038	01N/03W-31D	EAST VALLEY WATER DISTRICT	PLANT NO 69	W		2005	0	0	0	0	0	0	0	0	0	0	0
0000039	01S/03W-06E	EAST VALLEY WATER DISTRICT	PLANT NO 70	W		2005	0	0	0	0	0	0	0	0	0	0	0
0000040	01S/03W-06B	EAST VALLEY WATER DISTRICT	PLANT NO 71	W		2005	0	0	0	0	0	0	0	0	0	0	0
			PLANT NO 72	W		2005	0	0	0	0	0	0	0	0	0	0	0

**WESTERN - SAN BERNARDINO WATERMASTER
 VERIFIED PRODUCTION DATA - NON PLAINTIFFS
 CROSS INDEX BY RECORDATION NUMBER
 SAN BERNARDINO BASIN**

RECRD TN NUMBER	STATE WELL NUMBER	OWNER	WELL TYPE	LOCAL DESIGNATION	YEAR CLOSED	-----CALENDAR YEAR EXTRACTIONS-----										
						2008	2009	2010	2011	2012	AVG					
0000041	01S/03W-06C	EAST VALLEY WATER DISTRICT	W	PLANT NO 74	2005	0	0	0	0	0	0	0	0	0	0	
0000042	01S/04W-02L	EAST VALLEY WATER DISTRICT	W	PLANT NO 75	2005	0	0	0	0	0	0	0	0	0	0	
0000043	01S/03W-06P	EAST VALLEY WATER DISTRICT	W	PLANT NO 78	2005	0	0	0	0	0	0	0	0	0	0	
0000044	01S/03W-05Q	EAST VALLEY WATER DISTRICT	W	PLANT NO 80	2005	0	0	0	0	0	0	0	0	0	0	
0000045	01S/03W-06M	EAST VALLEY WATER DISTRICT	W	PLANT NO 81	2005	0	0	0	0	0	0	0	0	0	0	
0000046	01S/03W-06Q	EAST VALLEY WATER DISTRICT	W	PLANT NO 83	2005	0	0	0	0	0	0	0	0	0	0	
0000047	01S/03W-03N	EAST VALLEY WATER DISTRICT	W	PLANT NO 84	2005	0	0	0	0	0	0	0	0	0	0	
0000048	01N/04W-25D	EAST VALLEY WATER DISTRICT	W	PLANT NO 85	2005	0	0	0	0	0	0	0	0	0	0	
0000049	01S/03W-03N	EAST VALLEY WATER DISTRICT	W	PLANT NO 93	2005	0	0	0	0	0	0	0	0	0	0	
0000050	01S/03W-05J	EAST VALLEY WATER DISTRICT	W	PLANT NO 95	2005	0	0	0	0	0	0	0	0	0	0	
0000051	01S/04W-01D	EAST VALLEY WATER DISTRICT	W	PLANT NO 96	2005	0	0	0	0	0	0	0	0	0	0	
0000052	01S/03W-06N	EAST VALLEY WATER DISTRICT	W	PLANT NO 97	2005	0	0	0	0	0	0	0	0	0	0	
0000053	01S/03W-04R	QUALITY FARMS	W	NO. 102	2007	0	0	0	0	0	0	0	0	0	0	
0000054	01N/04W-08N	ELLENA, JOHN B.	W		1977	0	0	0	0	0	0	0	0	0	0	
0000055	01S/02W-24C	ELLGOOD,	W			0	0	0	0	0	0	0	0	0	0	
0000056	01S/02W-22E	FARROW,	W			5	5	5	5	5	5	5	5	5	5	
0000057	01S/02W-29C	FINCH,	W	FINCH	2004	0	0	0	0	0	0	0	0	0	0	
0000058	01S/04W-13E	GOLCONDA WATER COMPANY	W		1969	0	0	0	0	0	0	0	0	0	0	
0000059	01S/03W-04Q	EAST VALLEY WATER DISTRICT	W	PLANT NO 106	1974	0	0	0	0	0	0	0	0	0	0	
0000060	01S/02W-16L	HAGAR,	W		2007	0	0	0	0	0	0	0	0	0	0	
0000061	01N/04W-13Q	HARDISON,	W	KING STREET MUTUAL		1	1	1	1	0	0	0	1	1	1	
0000062	01S/03W-04J01S	HARRISON,	W		2007	0	0	0	0	0	0	0	0	0	0	
0000063	01N/04W-13N	HARRISON CANYON	W		2012	0	0	0	0	0	0	0	0	0	0	
0000064	01N/04W-13N	HARRISON CANYON	W			0	0	0	0	0	0	0	0	1	0	
0000065	01S/04W-11G	HAZAS,	W		1999	0	0	0	0	0	0	0	0	0	0	
0000066	01S/04W-15G	HELIPORT	W		2005	0	0	0	0	0	0	0	0	0	0	
0000067	01S/02W-31B	HILL,	W		2004	0	0	0	0	0	0	0	0	0	0	
0000068	01S/04W-14E	HOLDEN MUTUAL WATER COMPANY	W		1999	0	0	0	0	0	0	0	0	0	0	
0000069	01S/04W-14F	HOLDEN MUTUAL WATER COMPANY	W	HOLDEN AVE.	1999	0	0	0	0	0	0	0	0	0	0	
0000070	01S/03W-32J	HORTON,	W	LA PAPER BOX		248	315	267	222	222	356	282				
0000071	01S/03W-03D	HUNTER,	W		1978	0	0	0	0	0	0	0	0	0	0	
0000072	01S/04W-23P	INTER CITY MUTUAL WATER COMPANY	W		1977	0	0	0	0	0	0	0	0	0	0	
0000073	01N/04W-14R	KING,	W			1	1	1	1	1	1	1	1	1	1	
0000074	01S/02W-32B	KOCH,	W		2005	0	0	0	0	0	0	0	0	0	0	
0000075	01S/04W-11F	KRANTZ DAIRY	W		2007	0	0	0	0	0	0	0	0	0	0	
0000076	01S/03W-06L	EAST VALLEY WATER DISTRICT	W	LANKERSHIM A	2005	0	0	0	0	0	0	0	0	0	0	
0000077	01S/03W-06F	EAST VALLEY WATER DISTRICT	W	MCKINLEY ST.	2005	0	0	0	0	0	0	0	0	0	0	

**WESTERN - SAN BERNARDINO WATERMASTER
VERIFIED PRODUCTION DATA - NON PLAINTIFFS
CROSS INDEX BY RECORDATION NUMBER
SAN BERNARDINO BASIN**

RECRD TN NUMBER	STATE WELL NUMBER	OWNER	WELL TYPE	LOCAL DESIGNATION	YEAR CLOSED	-----CALENDAR YEAR EXTRACTIONS-----										
						2008	2009	2010	2011	2012	AVG					
0000078	01S/02W-28M	DANGERMOND, JACK	W	LA TOURETTE	2005	0	0	0	0	0	0	0	0	0	0	
0000079	01S/02W-28M	DANGERMOND, JACK	D	SPRING DIV.	1972	0	0	0	0	0	0	0	0	0	1	
0000080	01S/03W-13C	L. P. R. RANCH	W			100	100	100	100	100	100	100	100	100	100	
0000081	01S/03W-17G	MARSHBURN,	W			0	0	0	0	0	0	0	0	0	0	
0000082	01N/03W-31Q	BASELINE LAUNDRY	W			1990										
0000083	01S/02W-19J	MENTONE DOMESTIC WATER COMPANY	W			1978	0	0	0	0	0	0	0	0	0	
0000084	01S/04W-24K	MOORE, R. H.	W			2007	0	0	0	0	0	0	0	0	0	
0000085	01N/03W-32M	NO NAME WELL	W			2005	0	0	0	0	0	0	0	0	0	
0000086	01S/04W-07D	INLAND VALLEY DEVELOPMENT AGENCY	W	LOCAL NO. 2	1997	0	0	0	0	0	0	0	0	0	0	
0000087	01S/04W-12C	INLAND VALLEY DEVELOPMENT AGENCY	W	LOCAL NO. 3	1997	0	0	0	0	0	0	0	0	0	0	
0000088	01S/04W-12D	INLAND VALLEY DEVELOPMENT AGENCY	W	LOCAL NO. 4	2005	0	0	0	0	0	0	0	0	0	0	
0000089	01S/04W-12F	INLAND VALLEY DEVELOPMENT AGENCY	W	LOCAL NO. 5	1997	0	0	0	0	0	0	0	0	0	0	
0000090	01S/03W-07A	INLAND VALLEY DEVELOPMENT AGENCY	W	LOCAL NO.11	1997	0	0	0	0	0	0	0	0	0	0	
0000091	01S/04W-12Q	INLAND VALLEY DEVELOPMENT AGENCY	W	NO NO. WELL	2005	0	0	0	0	0	0	0	0	0	0	
0000092	01S/04W-12G	INLAND VALLEY DEVELOPMENT AGENCY	W	LOCAL NO. 44	2005	0	0	0	0	0	0	0	0	0	0	
0000093	01S/03W-08E	INLAND VALLEY DEVELOPMENT AGENCY	W	LOCAL NO.347	2005	0	0	0	0	0	0	0	0	0	0	
0000094	01S/03W-08M	INLAND VALLEY DEVELOPMENT AGENCY	W	LOCAL NO.865	2005	0	0	0	0	0	0	0	0	0	0	
0000095	01N/03W-34F	NORWOOD,	W			2007	0	0	0	0	0	0	0	0	0	
0000096	01N/04W-35H	PACIFIC HIGH SCHOOL	W			1965	0	0	0	0	0	0	0	0	0	
0000097	01N/04W-35N	PIERSON,	W			1999	0	0	0	0	0	0	0	0	0	
0000098	01S/02W-22F	RAMSEY,	D	SPRING DIV	2007	0	0	0	0	0	0	0	0	0	0	
0000099	01S/02W-17B	REDLANDS ASSOCIATES	W	#0	2007	0	0	0	0	0	0	0	0	0	0	
0000100	01S/02W-09P	REDLANDS ASSOCIATES	W	BLOCK NO. 6	1972	0	0	0	0	0	0	0	0	0	0	
0000101	01S/02W-09L	REDLANDS ASSOCIATES	W	BLOCK NO. 11	1972	0	0	0	0	0	0	0	0	0	0	
0000102	01S/02W-09L	REDLANDS ASSOCIATES	D	TUNNEL DIV.	1980	0	0	0	0	0	0	0	0	0	0	
0000103	01S/02W-13B	REDLANDS, CITY OF	D	MILL CREEK DIV	1980	0	0	0	0	0	0	0	0	0	0	
0000104	01S/02W-08A	REDLANDS WATER COMPANY	D	REDLANDS WATER COM		625	654	629	739	529	635					
0000105	01N/05W-04M	REGINA GRAPE PRODUCTS	W	WELL NO. 1	1985	0	0	0	0	0	0	0	0	0	0	
0000106	01N/05W-04N	REGINA GRAPE PRODUCTS	W	WELL NO. 2	1985	0	0	0	0	0	0	0	0	0	0	
0000107	01N/05W-04N	REGINA GRAPE PRODUCTS	W	WELL NO. 3	1985	0	0	0	0	0	0	0	0	0	0	
0000108	01N/05W-05C	REGINA GRAPE PRODUCTS	D	SPRING DIV.	1985	0	0	0	0	0	0	0	0	0	0	
0000109	01N/05W-05R	REGINA GRAPE PRODUCTS	W	WELL NO. 4	1985	0	0	0	0	0	0	0	0	0	0	
0000110	01N/05W-04N	REGINA GRAPE PRODUCTS	W	WELL NO. 5	1985	0	0	0	0	0	0	0	0	0	0	
0000111	01N/05W-04N	REGINA GRAPE PRODUCTS	W	WELL NO. 6	1985	0	0	0	0	0	0	0	0	0	0	
0000112	01N/05W-04N	REGINA GRAPE PRODUCTS	W	WELL NO. 7	1985	0	0	0	0	0	0	0	0	0	0	
0000113	01S/04W-24J	RIVAS,	W			1987	0	0	0	0	0	0	0	0	0	
0000114	01N/03W-34K	RULE,	W	SPRING	1974	0	0	0	0	0	0	0	0	0	0	

**WESTERN - SAN BERNARDINO WATERMASTER
VERIFIED PRODUCTION DATA - NON PLAINTIFFS
CROSS INDEX BY RECORDATION NUMBER
SAN BERNARDINO BASIN**

RECRD TN NUMBER	STATE WELL NUMBER	OWNER	WELL TYPE	LOCAL DESIGNATION	YEAR CLOSED	-----CALENDAR YEAR EXTRACTIONS-----										
						2008	2009	2010	2011	2012	AVG					
0000115	01S/04W-21A	SAN BERNARDINO, CITY OF	W	SEWER PLANT 1	2006	0	0	0	0	0	0	0	0	0	0	
0000116	01S/04W-22C	SAN BERNARDINO, CITY OF	W	SEWER PLANT 2	2005	0	0	0	0	0	0	0	0	0	0	
0000119	01N/03W-20N	SAN MANUEL INDIAN RESERVATION	W			0	0	0	0	0	0	0	0	0	0	
0000120	01S/04W-14A	SANTINI,	W		2007	0	0	0	0	0	0	0	0	0	0	
0000121	01N/04W-14J	SATOSKI,	W			1	1	1	1	1	1	1	1	1	1	
0000122	01N/03W-19Q	SELEY,	D	TUNNEL DIV.	2007	0	0	0	0	0	0	0	0	0	0	
0000123	01S/04W-22A	SIX HOUSES	W		1985	0	0	0	0	0	0	0	0	0	0	
0000124	01N/04W-14J	SMITH,	W			1	1	1	1	1	1	1	1	1	1	
0000125	01S/03W-02J	SMITH,	W			10	20	20	7	37	19					
0000126	01S/04W-22M01S	SMITH MEAT PACKING PLANT	W		1999	0	0	0	0	0	0	0	0	0	0	
0000127	01S/02W-24H	STANLEY, SILAS	W		2007	0	0	0	0	0	0	0	0	0	0	
0000128	01S/03W-31D	STEWART, WILLARD	W		1978	0	0	0	0	0	0	0	0	0	0	
0000129	01S/03W-03N	STRAWBERRY PATCH	W		2006	0	0	0	0	0	0	0	0	0	0	
0000130	01S/03W-03N	STRAWBERRY PATCH	W		2006	0	0	0	0	0	0	0	0	0	0	
0000131	01N/03W-29B	SUPERIOR ORCHARDS	D	TUNNEL DIV.	1985	0	0	0	0	0	0	0	0	0	0	
0000132	01N/03W-28A	THOMPSON, RANDALL	D	SPRING DIV.	2005	0	0	0	0	0	0	0	0	0	0	
0000133	01S/04W-23N	TRI-CITY MUTUAL WATER COMPANY	W		1971	0	0	0	0	0	0	0	0	0	0	
0000134	01S/01W-19G	TRIPLE FALLS MUTUAL WATER COMPANY	W		1975	0	0	0	0	0	0	0	0	0	0	
0000135	01S/01W-20D	TRIPLE FALLS MUTUAL WATER COMPANY	W		1975	0	0	0	0	0	0	0	0	0	0	
0000136	01S/01W-20D	TRIPLE FALLS MUTUAL WATER COMPANY	W		1975	0	0	0	0	0	0	0	0	0	0	
0000137	01N/04W-13Q	U. S. FOREST SERVICE	W	MAINT. YARD	1971	0	0	0	0	0	0	0	0	0	0	
0000138	01S/02W-13P	U. S. FOREST SERVICE	W	MILL CREEK	1965	0	0	0	0	0	0	0	0	0	0	
0000139	01S/02W-17A	UNIVERSITY OF REDLANDS	W	PEPPER HOUSE		5	5	5	5	5	10	6				
0000140	01N/04W-23K	VALENCIA AVE. MUTUAL WATER COMPANY	W	WATERMAN AVE	2007	0	0	0	0	0	0	0	0	0	0	
0000141	01S/04W-15R	VALLEY FARMS MUTUAL WATER COMPANY	W	NO 1 WASHTN	2001	0	0	0	0	0	0	0	0	0	0	
0000142	01S/04W-15Q	VALLEY FARMS MUTUAL WATER COMPANY	W	NO 2 WELL	2001	0	0	0	0	0	0	0	0	0	0	
0000143	01S/04W-24J	VANLEUVEN, CLARENCE	W		1980	0	0	0	0	0	0	0	0	0	0	
0000144	01S/04W-24J	VICTORIA SEVENTH DAY ADVENTIST	W			10	10	10	10	10	10	10	10	10	10	
0000145	01S/04W-24J	MT. VIEW CHILD CARE CENTER	W		2007	0	0	0	0	0	0	0	0	0	0	
0000146	01S/03W-02P	VAN MEETER,	W	OLD WELL	2007	0	0	0	0	0	0	0	0	0	0	
0000147	01S/03W-02P	VAN MEETER,	W	NEW WELL	2007	0	0	0	0	0	0	0	0	0	0	
0000148	01N/04W-14J	WALLACE,	W		2012	1	1	1	1	1	1	1	1	1	1	
0000149	01S/01W-18N	WARD, FLOYD	W	WELL NO. 1		0	0	0	0	0	0	1	0	0	0	
0000150	01S/01W-18P	WARD, FLOYD	W	WELL NO. 2		0	0	0	0	0	0	10	2			
0000151	01S/01W-18P	WARD, FLOYD	W	WELL NO. 3		1	1	1	1	1	1	0	1	1	1	
0000152	01S/01W-18N	WARD, FLOYD	W	WELL NO. 4		0	0	0	0	0	0	0	1	0	0	
0000153	01S/01W-18M	WARD, FLOYD	W	WELL NO. 6	2012	0	0	0	0	0	0	0	0	0	0	

**WESTERN - SAN BERNARDINO WATERMASTER
 VERIFIED PRODUCTION DATA - NON PLAINTIFFS
 CROSS INDEX BY RECORDATION NUMBER
 SAN BERNARDINO BASIN**

RECRD TN NUMBER	STATE WELL NUMBER	OWNER	WELL TYPE	LOCAL DESIGNATION	YEAR CLOSED	-----CALENDAR YEAR EXTRACTIONS-----										
						2008	2009	2010	2011	2012	AVG					
0000154	01S/01W-18P	WARD, FLOYD	D	LATERAL SPR S	2012	0	0	0	0	0	0	0	0	0	0	
0000156	01S/03W-24Q	WESTERN FRUIT GROWERS	W		1979	0	0	0	0	0	0	0	0	0	0	
0000157	01N/03W-29H	WIDEMEYER,	D	SPRING DIV.	2005	0	0	0	0	0	0	0	0	0	0	
0000158	01N/03W-29H	WIDEMEYER,	W		2005	0	0	0	0	0	0	0	0	0	0	
0000159	01S/04W-11G	WILLIAMS DAIRY	W		2005	0	0	0	0	0	0	0	0	0	0	
0000160	01N/03W-19R	SAN MANUEL INDIAN RESERVATION	W	DOMESTIC	1	1	1	1	1	1	1	1	1	1	1	
0000161	01N/03W-19R	SAN MANUEL INDIAN RESERVATION	W		15	15	15	15	15	15	15	15	15	15	15	
0000162	01N/03W-19R	SAN MANUEL INDIAN RESERVATION	D	YORK TUNNEL	0	0	0	0	0	0	0	0	0	0	0	
0000163	01N/03W-34Q	PATTERSON, ROY H.	W		2007	0	0	0	0	0	0	0	0	0	0	
0000164	01S/03W-20Q	MCCALLA BROS.	W		1984	0	0	0	0	0	0	0	0	0	0	
0000165	01S/03W-21M02S	SANDY'S RESTAURANT	W		2005	0	0	0	0	0	0	0	0	0	0	
0000166	01S/02W-22C	GREENSPOT MUTUAL WATER CO. TUNNEL	D		50	50	50	50	50	50	50	50	50	50	50	
0000173	01N/04W-24C	DILLSON MUTUAL WATER COMPANY	W	CISCO WELL	0	0	0	0	0	0	0	0	0	0	0	
0000175	01S/03W-19J	DANIELS, DON	W		1973	0	0	0	0	0	0	0	0	0	0	
0000176	01S/02W-19J	MENTONE DOMESTIC WATER COMPANY	W	3 1971	1975	0	0	0	0	0	0	0	0	0	0	
0000178	01S/03W-32G	KUHN, RICHARD J.	W		0	0	0	0	0	0	0	0	0	0	0	
0000181	01S/04W-14F	UNKNOWN	W	FOISTY STREET	2007	0	0	0	0	0	0	0	0	0	0	
3600001	01S/03W-21R02S	SMITH TRACT WELL COMPANY	W	11	1978	0	0	0	0	0	0	0	0	0	0	
3600001-	01S/03W-21R01S	SMITH TRACT WELL COMPANY	W		1972	0	0	0	0	0	0	0	0	0	0	
3600005	01S/03W-35H08S	REDLANDS, CITY OF	W	LUETCKE	1981	0	0	0	0	0	0	0	0	0	0	
3600006	01S/02W-19G01S	REDLANDS, CITY OF	W	E. LUGONIA #5	0	0	0	0	0	0	0	0	0	0	0	
3600016	01S/04W-24J	RIVAS, RAMON	W	REES 4	1981	0	0	0	0	0	0	0	0	0	0	
3600017	01S/02W-29P	SELBY DR & MRS	W	GRREES 3	0	0	0	0	0	0	0	0	0	0	0	
3600018	01S/02W-29P	REES-REES RANCHES INC	W	GRREES 2	0	0	0	0	0	0	0	0	0	0	0	
3600019	01S/03W-23A05S	REDLANDS, CITY OF	W	GR REES 1	0	258	1,114	1,759	1,633	953	0	0	0	0	0	
3600021	01N/02W-26H	BEAR VALLEY MUTUAL WATER COMPANY	W	SANTA A1	182	0	0	0	0	0	0	0	0	0	36	
3600022	01N/02W-26H	BEAR VALLEY MUTUAL WATER COMPANY	W	SA #2	1998	0	0	0	0	0	0	0	0	0	0	
3600023	01S/03W-24C	BEAR VALLEY MUTUAL WATER COMPANY	W	JUDSON1	0	0	0	0	0	0	0	0	0	0	0	
3600024	01S/02W-19D	BEAR VALLEY MUTUAL WATER COMPANY	W	WABASH 2	1974	0	0	0	0	0	0	0	0	0	0	
3600025	01N/03W-29R01S	BEAR VALLEY MUTUAL WATER COMPANY	W	PALM AV3	1977	0	0	0	0	0	0	0	0	0	0	
3600026	01S/03W-04J01S	GREENSPOT VILLAGE & MARKET PLACE LLC	W	PL 102	0	0	0	0	0	0	0	0	0	0	0	
3600027	01N/02W-10N	BEAR VALLEY MUTUAL WATER COMPANY	D		1974	0	0	0	0	0	0	0	0	0	0	
3600028	01S/02W-04N	BEAR VALLEY MUTUAL WATER COMPANY	D	SANTA ANA RIVER MAIN	13,519	10,368	17,524	16,862	15,560	14,767	0	0	0	0	0	
3600030	01S/04W-23D	MEADOWBROOK DAIRY	W	IRRIG 2	2004	0	0	0	0	0	0	0	0	0	0	
3600034	01S/04W-16H	SAN BERNARDINO, CITY OF	W	SMITH 1	1979	0	0	0	0	0	0	0	0	0	0	
3600035	01S/04W-15M01S	SAN BERNARDINO, CITY OF	W		1979	0	0	0	0	0	0	0	0	0	0	
3600036	01S/03W-33D	BROOKSIDE DAIRY INC	W	1	1989	0	0	0	0	0	0	0	0	0	0	

**WESTERN - SAN BERNARDINO WATERMASTER
VERIFIED PRODUCTION DATA - NON PLAINTIFFS
CROSS INDEX BY RECORDATION NUMBER
SAN BERNARDINO BASIN**

RECRD TN NUMBER	STATE WELL NUMBER	OWNER	WELL TYPE	LOCAL DESIGNATION	YEAR CLOSED	-----CALENDAR YEAR EXTRACTIONS-----										
						2008	2009	2010	2011	2012	AVG					
3600037	01S/04W-23D	MEADOWBROOK DAIRY	W	DOMESTIC 1	2004	0	0	0	0	0	0	0	0	0	0	
3600038	01S/02W-17N	REDLANDS, CITY OF	D	DRY CREEK DIVERSION	1974	0	0	0	0	0	0	0	0	0	0	
3600049	01S/03W-25N01S	REDLANDS COUNTRY CLUB	W	MORRISON	1978	0	0	0	0	0	0	0	0	0	0	
3600049-	01S/03W-25N02S	REDLANDS COUNTRY CLUB	W	MORRISON/HOBBS	2006	0	0	0	0	0	0	0	0	0	0	
3600052	01S/04W-36J	WILEY, RUTH NORWOOD	W	1	1974	0	0	0	0	0	0	0	0	0	0	
3600053	01S/03W-31A02S	REDLANDS, CITY OF	W	1, BRYN MAWR		0	0	0	0	0	0	0	0	0	0	
3600054	01S/03W-31A03S	REDLANDS, CITY OF	W	2, BRYN MAWR MUTUAL	1964	0	0	0	0	0	0	0	0	0	0	
3600055	01S/03W-31A06S	REDLANDS, CITY OF	W	3, BRYN MAWR MUTUAL	1975	0	0	0	0	0	0	0	0	0	0	
3600058	01S/03W-03F02S	EAST VALLEY WATER DISTRICT	W	PL 53 / EUCALYPTUS	2001	0	0	0	0	0	0	0	0	0	0	
3600075	01S/03W-28C01S	GRANT WATER COMPANY	W	GRANT	1991	0	0	0	0	0	0	0	0	0	0	
3600076	01S/03W-17G	ARMSTRONG, DOUGLAS	W	2	1971	0	0	0	0	0	0	0	0	0	0	
3600083	01N/05W-06P	STORKSON, DAVID D.	W	1		65	57	64	30	59	55					
3600085	01S/03W-28J01S	REDLANDS, CITY OF	W	NY ST 1	1966	0	0	0	0	0	0	0	0	0	0	
3600091	01S/03W-20R	JEWEL WATER COMPANY	W	1	1976	0	0	0	0	0	0	0	0	0	0	
3600107	01S/03W-21P01S	B M I FUNDS	W	COLTON 1	1966	0	0	0	0	0	0	0	0	0	0	
3600119	01S/04W-26F01S	MONTECITO MEMORIAL PARK	W	1		270	270	223	130	155	210					
3600123	01S/03W-20R01S	NICKERSON WATER COMPANY	W	1	1988	0	0	0	0	0	0	0	0	0	0	
3600124	01S/03W-21M01S	NICKERSON WATER COMPANY NO 2	W	2	1981	0	0	0	0	0	0	0	0	0	0	
3600125	01S/03W-14P	SAN BERNARDINO AVE WATER CO.	W	1		0	0	0	0	0	0	0	0	0	0	
3600139	01S/02W-18R01S	MENTONE CITRUS GROWERS	W	1-PRH RANCH		148	153	117	114	71	121					
3600160	01S/03W-32G01S	CANYON RANCH	W	GUNTER		0	0	0	0	0	0	0	0	0	0	
3600178	01S/04W-08F02S	ATCHISON TOPEKA & SANTA FE RAILWAY	W	3	1980	0	0	0	0	0	0	0	0	0	0	
3600179	01S/04W-08F	ATCHISON TOPEKA & SANTA FE RAILWAY	W	4	1980	0	0	0	0	0	0	0	0	0	0	
3600182	01S/03W-20H01S	GLADYSTA WELL & WATER COMPANY	W	1	1978	0	0	0	0	0	0	0	0	0	0	
3600182-	01S/03W-20H02S	GLADYSTA WELL & WATER COMPANY	W			51	65	88	99	143	89					
3600183	01S/04W-02A	EAST VALLEY WATER DISTRICT	W	PL 60	2003	0	0	0	0	0	0	0	0	0	0	
3600184	01N/03W-28N01S	HIGHLAND WELL COMPANY	W	HWC 1	1974	0	0	0	0	0	0	0	0	0	0	
3600187	01S/02W-09Q01S	LANDMARK LAND COMPANY	W	1, SOLANO WELL #1	2000	0	0	0	0	0	0	0	0	0	0	
3600188	01S/02W-16C	GRAM-PATTERSON WELL	W	CRAMPAT2		531	596	415	415	534	498					
3600218	01N/04W-24A	LANGSTON-NEWBY DEVELOPMENT COMPANY	W	1	1980	0	0	0	0	0	0	0	0	0	0	
3600220	01S/03W-01H01S	EAST VALLEY WATER DISTRICT	W	PLANT #142 / MT. H		425	445	624	503	600	519					
3600221	01N/03W-30J	EAST VALLEY WATER DISTRICT	W	PL 63	2001	0	0	0	0	0	0	0	0	0	0	
3600222	01S/04W-11Q01S	SAN BERNARDINO, CITY OF	W	MCFARLAND JOHNSON	2000	0	0	0	0	0	0	0	0	0	0	
3600226	01S/02W-21L01S	HEAD, JOE T.	W	1	1960	0	0	0	0	0	0	0	0	0	0	
3600238	01S/02W-29M01S	HAPPE MUTUAL WELL COMPANY	W	1		24	97	71	79	63	67					
3600240	01S/02W-30B	HINCKLEY, HORACE P.	W	SOUTH WELL	1982	0	0	0	0	0	0	0	0	0	0	
3600241	01S/03W-03Q	VILLAGE LAKES	W	1-HOME		85	85	85	85	85	85	85	85	85	85	

**WESTERN - SAN BERNARDINO WATERMASTER
VERIFIED PRODUCTION DATA - NON PLAINTIFFS
CROSS INDEX BY RECORDATION NUMBER
SAN BERNARDINO BASIN**

RECRD TN NUMBER	STATE WELL NUMBER	OWNER	WELL TYPE	LOCAL DESIGNATION	YEAR CLOSED	-----CALENDAR YEAR EXTRACTIONS-----										
						2008	2009	2010	2011	2012	AVG					
3600266	01S/02W-16C01S	GREENSPOT MUTUAL WELL COMPANY	W	GRNSPTMU	2007	215	311	141	138	188	199					
3600269	01N/03W-31L01S	EAST VALLEY WATER DISTRICT	W	PL 68	1979	0	0	0	0	0	0					
3600270	01S/03W-20P	WARMINGTON, ROBERT P.	W	RDLNDS 1	1979	0	0	0	0	0	0					
3600272	01S/02W-29N	CRAFTON WATER COMPANY	W	5TH AVE, # 1		684	530	99	10	14	267					
3600275	01N/03W-32B	EAST VALLEY WATER DISTRICT	W	PL 64	2003	0	0	0	0	0	0					
3600291	01S/04W-12N	MAYBELL, N O	W		1965	0	0	0	0	0	0					
3600296	01S/03W-15R01S	NORTHBRAE WATER COMPANY	W	1	1974	0	0	0	0	0	0					
3600302	01N/05W-26A01S	WEST VALLEY WATER DIST	W	#03 / LOWER 2	1967	0	0	0	0	0	0					
3600303	01N/05W-26B01S	WEST VALLEY WATER DIST	W	LOWER 4	1959	0	0	0	0	0	0					
3600304	01N/05W-26A03S	WEST VALLEY WATER DIST	W	#04 / LOWER 5	2003	0	0	0	0	0	0					
3600305	01N/05W-25E01S	WEST VALLEY WATER DIST	W	#05 / LOWER 6	2002	0	0	0	0	0	0					
3600306	01N/05W-23P02S	WEST VALLEY WATER DIST	W	UPPER 2	1967	0	0	0	0	0	0					
3600307	01N/05W-23P04S	WEST VALLEY WATER DIST	W	#01 / UPPER 4	2007	0	0	0	0	0	0					
3600312	01N/05W-22M	WEST VALLEY WATER DIST	D	LYTLE CREEK		3,369	3,189	3,322	3,381	2,954	3,243					
3600313	01S/02W-29N01S	CRAFTON WATER COMPANY	W	NYE	1967	0	0	0	0	0	0					
3600319	01N/04W-31A01S	MOUNT VERNON WATER CO.	W	1		927	1,132	167	685	799	742					
3600320	01N/05W-22M	SAN BERNARDINO, CITY OF	D	MT VERNON		0	0	0	0	0	0					
3600323	01S/02W-06M	HIGHLAND ACRES RANCH	W	ELEC 1	1998	0	0	0	0	0	0					
3600374	01N/03W-33M01S	EAST VALLEY WATER DISTRICT	W	PL 138/PALM 1	2000	0	0	0	0	0	0					
3600375	01S/03W-05D	EAST VALLEY WATER DISTRICT	W	PL 132/CULL 1	2000	0	0	0	0	0	0					
3600376	01S/03W-05D03S	EAST VALLEY WATER DISTRICT	W	PL 132/CULL 2		0	0	0	0	0	0					
3600377	01N/03W-27N08S	EAST VALLEY WATER DISTRICT	W	PL 134/CC1	2003	0	0	0	0	0	0					
3600378	01N/03W-27N02S	EAST VALLEY WATER DISTRICT	W	PL 134/CC3	2003	0	0	0	0	0	0					
3600399	01S/04W-02D	VICTORIA GUERNSEY	W	1	1968	0	0	0	0	0	0					
3600415	01S/03W-29J01S	PHAROAH-POWELL WATER CO	W			199	241	182	169	218	202					
3600418	01S/03W-19G	BARTON DEVELOPMENT C/O LUCKY FARMS	W	LUGONIA		256	280	259	252	250	259					
3600444	01N/03W-30H01S	EAST VALLEY WATER DISTRICT	W	PL 98		0	0	0	0	0	0					
3600449	01S/03W-20A	BELL, EUGENE	W	CALVARY CHAPEL		108	139	73	20	1	68					
3600451	01S/03W-15M	TROJAN GROVES	W			1	1	0	1	1	1					
3600456	01N/03W-33R02S	BASE LINE WELL COMPANY	W	1	1959	0	0	0	0	0	0					
3600457	01N/04W-35J02S	BASELINE GARDENS MUTUAL WATER COMPANY	W	1 STANDBY	1992	0	0	0	0	0	0					
3600458	01N/04W-36M01S	BASELINE GARDENS MUTUAL WATER COMPANY	W	PS & B 2		0	0	0	0	0	0					
3600466	01S/03W-04C	EAST VALLEY WATER DISTRICT	W	PL 48	2000	0	0	0	0	0	0					
3600468	01S/03W-30Q	SAN BERNARDINO COUNTY - FACILITY MANAGE	W	BAHR 1	1971	0	0	0	0	0	0					
3600474	01S/03W-16L	TENNESSEE WATER COMPANY	W	1		309	303	226	192	211	248					
3600483	01S/02W-31F	SECHREST, RALPH F.	W	GPHRRCH1	1980	0	0	0	0	0	0					
3600484	01S/03W-16F	RAMIREZ, J. J.	W	BUCKEYE2		0	0	0	0	0	0					

**WESTERN - SAN BERNARDINO WATERMASTER
VERIFIED PRODUCTION DATA - NON PLAINTIFFS
CROSS INDEX BY RECORDATION NUMBER
SAN BERNARDINO BASIN**

RECRD TN NUMBER	STATE WELL NUMBER	OWNER	WELL TYPE	LOCAL DESIGNATION	YEAR CLOSED	-----CALENDAR YEAR EXTRACTIONS-----										
						2006	2007	2008	2009	2010	2011	2012	AVG			
3600493	01S/03W-29K	MONTE LLC	W	2 NEW WELL	2006	0	0	0	0	0	0	0	0	0	0	0
3600494	01S/03W-29K	MONTE LLC	W	1 OLD WELL	2003	65	59	65	53	53	63	65	65	61		
3600510	01S/03W-21K01S	REDLANDS, CITY OF	W	LUGO #1	2003	0	0	0	0	0	0	0	0	0	0	0
3600523	01S/03W-32G03S	REDLANDS FARMING	W	HNTSCHKE	1980	0	0	0	0	0	0	0	0	0	0	0
3600524	01S/03W-17L01S	TRAMMELL CROW COMPANY	W	NEVADA ST	2006	0	0	0	0	0	0	0	0	0	0	0
3600525	01S/03W-17H01S	RAMIREZ, J. J.	W	ALABAMA	2007	0	0	0	0	0	0	0	0	0	0	0
3600526	01S/03W-21G01S	REDLANDS FARMING	W	LUGONIA	1981	0	0	0	0	0	0	0	0	0	0	0
3600527	01S/03W-16A	RAMIREZ, J. J.	W	MIDAS	1978	125	119	125	98	98	96	95	95	107		
3600530	01S/02W-30G01S	KING STREET MUTUAL WELL COMPANY	W	1	1978	0	0	0	0	0	0	0	0	0	0	0
3600530-	01S/02W-30G02S	KING STREET MUTUAL WELL COMPANY	W	2	2003	5	5	5	5	5	5	5	5	5	5	5
3600545	01N/03W-30J	EAST VALLEY WATER DISTRICT	W	PL 62	2003	0	0	0	0	0	0	0	0	0	0	0
3600554	01S/03W-17R	FAIRVIEW WATER COMPANY	W	FAIRVW 1	1987	266	286	266	102	102	80	71	161			
3600561	01N/05W-23K01S	FONTANA UNION WATER COMPANY	W	FU 1	1987	0	0	0	0	0	0	0	0	0	0	0
3600562	01N/05W-22F02S	FONTANA UNION WATER COMPANY	W	FU 3	1987	1,361	1,018	1,361	653	653	1,303	1,747	1,216			
3600563	01N/05W-22C02S	FONTANA UNION WATER COMPANY	W	FU 4	1987	1,501	1,274	1,501	922	922	1,976	2,272	1,589			
3600566	01N/05W-15Q02S	FONTANA UNION WATER COMPANY	W	FU 8	1962	0	0	0	0	0	0	0	0	0	0	0
3600569	01N/05W-22A01S	FONTANA UNION WATER COMPANY	W	FU 13	1987	2,512	2,161	2,512	1,360	1,360	1,585	2,586	2,041			
3600579	01N/05W-22F03S	FONTANA UNION WATER COMPANY	W	FU 24	1987	624	715	624	950	950	871	1,308	894			
3600580	01N/05W-22F01S	FONTANA UNION WATER COMPANY	W	FU 25	1987	222	0	222	0	0	0	0	44			
3600581	01N/05W-07H01S	FONTANA UNION WATER COMPANY	W	FU 26	1987	385	57	385	855	855	1,001	903	640			
3600582	01N/05W-06G01S	FONTANA UNION WATER COMPANY	W	FU 27	1987	419	121	419	170	170	255	1	193			
3600585	01N/05W-16K01S	FONTANA UNION WATER COMPANY	W	FU 32	1987	852	778	852	1,135	1,135	1,435	1,352	1,110			
3600586	01N/05W-06K02S	FONTANA UNION WATER COMPANY	W	FU 33	1987	1,482	1,559	1,482	1,028	1,028	553	1,382	1,201			
3600588	02N/06W-26L02S	FONTANA UNION WATER COMPANY	W	MILLER NARROWS #1	1981	0	0	0	0	0	0	0	0	0	0	0
3600590	02N/06W-26L01S	FONTANA UNION WATER COMPANY	W	MIL NAR 2	1986	0	0	0	0	0	0	0	0	0	0	0
3600591	01N/05W-06E	FONTANA UNION WATER COMPANY	W	BL AND FTF	1992	0	0	0	0	0	0	0	0	0	0	0
3600598	01S/03W-02L	EAST HIGHLAND RANCH	W	NEW 1	1997	0	0	0	0	0	0	0	0	0	0	0
3600599	01S/02W-13F	SUNRISE RANCH PARTNERSHIP	W	1	1991	0	0	0	0	0	0	0	0	0	0	0
3600600	01S/02W-14L	SUNRISE RANCH PARTNERSHIP	W	SUNRISE 2	1981	0	0	0	0	0	0	0	0	0	0	0
3600601	01S/02W-14F	SUNRISE RANCH PARTNERSHIP	W	SUN 3A	1981	0	0	0	0	0	0	0	0	0	0	0
3600602	01S/02W-15P	SUNRISE RANCH PARTNERSHIP	W	SUNRISE 4	1981	0	0	0	0	0	0	0	0	0	0	0
3600603	01S/02W-15G	SUNRISE RANCH PARTNERSHIP	W	SUNRISE 5	1991	0	0	0	0	0	0	0	0	0	0	0
3600604	01S/02W-07B	EAST HIGHLAND RANCH	W	RANNEY	1986	0	0	0	0	0	0	0	0	0	0	0
3600605	01N/03W-35G	EAST HIGHLAND RANCH	D	PLUNGE CK		0	0	0	0	0	0	0	0	0	0	0
3600606	01N/03W-35K	EAST HIGHLAND RANCH	D	ELDER GULCH		0	0	0	0	0	0	0	0	0	0	0
3600607	01S/03W-02L01S	EAST HIGHLAND RANCH	W	SMALL	1978	0	0	0	0	0	0	0	0	0	0	0
3600607-	01S/03W-02L02S	EAST HIGHLAND RANCH	W	WELL 3	1991	0	0	0	0	0	0	0	0	0	0	0

**WESTERN - SAN BERNARDINO WATERMASTER
VERIFIED PRODUCTION DATA - NON PLAINTIFFS
CROSS INDEX BY RECORDATION NUMBER
SAN BERNARDINO BASIN**

RECRD TN NUMBER	STATE WELL NUMBER	OWNER	WELL TYPE	LOCAL DESIGNATION	YEAR CLOSED	-----CALENDAR YEAR EXTRACTATIONS-----										
						2008	2009	2010	2011	2012	AVG					
3600608	01S/03W-28B01S	EAST BARTON WATER COMPANY	W	BARTON	1971	0	0	0	0	0	0	0	0	0	0	
3600628	01S/03W-15G	REDLANDS TRAP/SKEET	W		1980	0	0	0	0	0	0	0	0	0	0	
3600630	01N/03W-32D	MILLER MUTUAL WELL COMPANY	W		1961	0	0	0	0	0	0	0	0	0	0	
3600630-	01N/03W-32D	MILLER MUTUAL WELL COMPANY	W			5	5	5	5	5	5	5	5	5	5	
3600642	01S/03W-14P01S	PIONEER MUTUAL WATER CO	W	SBDNO 1		30	20	21	22	22	24	24	23			
3600643	01N/04W-25K01S	EAST VALLEY WATER DISTRICT	W	PL 66	2003	0	0	0	0	0	0	0	0	0	0	
3600644	01S/04W-09B03S	HOLMES ICE & COLD STORAGE	W	2	2003	0	0	0	0	0	0	0	0	0	0	
3600645	01S/04W-09B01S	HOLMES ICE & COLD STORAGE	W		1960	0	0	0	0	0	0	0	0	0	0	
3600651	01S/03W-28L	MOUNTAIN VIEW POWER CO.	W		1977	0	0	0	0	0	0	0	0	0	0	
3600652	01S/03W-15N01S	WEATHERWAX, W. G.	W	REDLANDS	1958	0	0	0	0	0	0	0	0	0	0	
3600678	01S/02W-08C01S	NORTH FORK WATER COMPANY	W	1	2001	0	0	0	0	0	0	0	0	0	0	
3600679	01S/02W-08C02S	NORTH FORK WATER COMPANY	W	N FORK #2	2001	0	0	0	0	0	0	0	0	0	0	
3600680	01S/03W-02J02S	EAST VALLEY WATER DISTRICT	W	PL 120 / CRAM		1,482	500	0	0	0	0	0	0	0	396	
3600681	01N/03W-27M	CITY CREEK WATER COMPANY	D	CITY CREEK	2000	0	0	0	0	0	0	0	0	0	0	
3600708	01S/03W-29B	LA ROSSE, CHARLES H	W	GOODWIN	1966	0	0	0	0	0	0	0	0	0	0	
3600709	02N/05W-19Q01S	SAN BERNARDINO, CITY OF	W	VINCENT	1970	0	0	0	0	0	0	0	0	0	0	
3600710	02N/05W-19K01S	SAN BERNARDINO, CITY OF	W	CAJON CYN		495	255	375	447	220	220	368				
3600711	01N/04W-07F01S	SAN BERNARDINO, CITY OF	W	DEVIL CANYON #2		1,040	964	1,525	1,318	665	1,102					
3600712	01N/04W-08M01S	SAN BERNARDINO, CITY OF	W	DEVIL CANYON #1		659	1,192	1,053	1,070	892	973					
3600713	01N/05W-36R01S	SAN BERNARDINO, CITY OF	W	LYTLE CREEK # 3-1		0	0	0	0	0	0	0	0	0	0	
3600714	01N/04W-16E01S	SAN BERNARDINO, CITY OF	W	NEWMARK #1		495	223	132	257	253	272					
3600715	01N/04W-16E02S	SAN BERNARDINO, CITY OF	W	NEWMARK #2		808	415	188	383	741	507					
3600716	01N/04W-16E03S	SAN BERNARDINO, CITY OF	W	NEWMARK #3		1,588	1,312	1,154	1,545	1,504	1,421					
3600717	01N/04W-32D03S	SAN BERNARDINO, CITY OF	W	19TH ST #1		348	0	0	0	0	70					
3600718	01N/04W-32D04S	SAN BERNARDINO, CITY OF	W	19TH ST #2		289	1,171	1,085	786	617	790					
3600719	01N/04W-27G01S	SAN BERNARDINO, CITY OF	W	30TH ST.		1,810	1,478	1,176	272	136	974					
3600720	01N/04W-27M02S	SAN BERNARDINO, CITY OF	W	27TH ST. & ACACIA		512	261	152	229	435	318					
3600721	01N/04W-27M01S	SAN BERNARDINO, CITY OF	W	25TH & N. "E" ST.		0	0	0	0	0	0	0	0	0	0	
3600722	01S/04W-03D01S	SAN BERNARDINO, CITY OF	W	11TH & E ST (ACACIA)	1968	0	0	0	0	0	0	0	0	0	0	
3600723	01S/04W-10F01S	SAN BERNARDINO, CITY OF	W	HANFORD 1	1968	0	0	0	0	0	0	0	0	0	0	
3600724	01S/04W-10F05S	SAN BERNARDINO, CITY OF	W	HANFORD 2	1968	0	0	0	0	0	0	0	0	0	0	
3600725	01N/04W-34G01S	SAN BERNARDINO, CITY OF	W	17 ST/SIERRA WAY #1		0	0	0	0	0	0	0	0	0	0	
3600726	01N/04W-34G03S	SAN BERNARDINO, CITY OF	W	16TH ST & SIERRA WAY		1,554	2,382	2,002	2,162	2,487	2,117					
3600727	01N/04W-26E02S	SAN BERNARDINO, CITY OF	W	LYNWOOD		1,460	1,071	1,049	302	244	825					
3600728	01N/04W-27A01S	SAN BERNARDINO, CITY OF	W	WATERMAN AVE.		1,293	1,163	1,247	1,563	1,570	1,367					
3600729	01N/04W-35M03S	SAN BERNARDINO, CITY OF	W	GILBERT ST.		1,012	78	88	36	222	287					
3600730	01S/04W-02K01S	SAN BERNARDINO, CITY OF	W	ANTIL #3	1981	0	0	0	0	0	0	0	0	0	0	

**WESTERN - SAN BERNARDINO WATERMASTER
VERIFIED PRODUCTION DATA - NON PLAINTIFFS
CROSS INDEX BY RECORDATION NUMBER
SAN BERNARDINO BASIN**

RECRD TN NUMBER	STATE WELL NUMBER	OWNER	WELL TYPE	LOCAL DESIGNATION	YEAR CLOSED	-----CALENDAR YEAR EXTRACTIONS-----										
						2008	2009	2010	2011	2012	AVG					
3600731	01S/04W-02K02S	SAN BERNARDINO, CITY OF	W	ANTIL #5		0	0	0	0	0	0	0	0	0	0	
3600732	01S/04W-02K05S	SAN BERNARDINO, CITY OF	W	ANTIL #2	1978	0	0	0	0	0	0	0	0	0	0	
3600733	01S/04W-02K04S	SAN BERNARDINO, CITY OF	W	ANTIL #1	1981	0	0	0	0	0	0	0	0	0	0	
3600734	01S/04W-02K03S	SAN BERNARDINO, CITY OF	W	ANTIL #4		0	0	0	0	0	0	0	0	0	0	
3600735	01S/04W-09P01S	SAN BERNARDINO, CITY OF	W	BIRCH ST.	1981	0	0	0	0	0	0	0	0	0	0	
3600736	01S/04W-09J01S	SAN BERNARDINO, CITY OF	W	SOUTH G ST	1978	0	0	0	0	0	0	0	0	0	0	
3600737	01S/04W-10N06S	SAN BERNARDINO, CITY OF	W	MILL & D		429	377	397	397	502	398	421				
3600738	01N/04W-06J	SAN BERNARDINO, CITY OF	D	DEVIL CYN DIVERSION		0	0	0	0	0	0	0	0	0	0	
3600739	01N/05W-06E	SAN BERNARDINO, CITY OF	D	LYTLE CK DIV.		0	0	0	0	0	0	0	0	0	0	
3600742	01N/04W-26N	MT. VIEW CEMETERY	W	1	1978	0	0	0	0	0	0	0	0	0	0	
3600742-	01N/04W-26N	MT. VIEW CEMETERY	W	MT VIEW #2 (#3 WEST)		104	109	123	123	151	114	120				
3600743	01N/04W-26M	MT. VIEW CEMETERY	W	MT VIEW #1 (#2 SHED)		141	126	119	119	111	161	132				
3600747	01N/03W-31P02S	FRIEDEMANN, ERNEST C.	W	WELL 1	1971	0	0	0	0	0	0	0	0	0	0	
3600748	01S/03W-24A01S	REDLANDS, CITY OF	W	MENTONE ACRES #1-OL		0	973	91	91	73	75	242				
3600749	01S/03W-13P01S	REDLANDS, CITY OF	W	MENTONE ACRES #2-NE		813	0	155	1,743	1,357	814					
3600756	01S/03W-19L01S	REDLANDS, CITY OF	W	MISSION #1		0	0	0	0	0	0	0	0	0	0	
3600757	01S/03W-19L	MARIGOLD FARMS COMPANY	W	2, MISSION #2		250	250	250	250	289	225	253				
3600760	01N/05W-01R	MEYER, CHARLES R	W	1	1991	0	0	0	0	0	0	0	0	0	0	
3600765	01N/03W-33C01S	DUCKWORTH, JOHN E.	W	113		1	0	0	0	0	0	0	0	0	0	
3600766	01S/03W-29A01S	ELTINGE & GRAZIADIO	W	COLTAMA	1971	0	0	0	0	0	0	0	0	0	0	
3600815	01S/03W-06L	CHARLES, J. J.	W		1959	0	0	0	0	0	0	0	0	0	0	
3600817	01S/03W-29H	WOEHR MUTUAL WATER COMPANY	W		1991	0	0	0	0	0	0	0	0	0	0	
3600828	01S/03W-16J	WILLIAMS WELL CORPORATION LTD	W	-		394	363	421	388	460	405					
3600855	01N/03W-28P01S	EAST VALLEY WATER DISTRICT	W	PL 54		0	0	0	0	0	0	0	0	0	0	
3600856	01N/03W-27M	GUERTH, WILLIAM H.	D	CITY CREEK	1967	0	0	0	0	0	0	0	0	0	0	
3600864	01N/03W-19F	EAST VALLEY WATER DISTRICT	W	PL 79	2003	0	0	0	0	0	0	0	0	0	0	
3600865	01N/04W-24H	LA BONTE, JIM	W	MULTOWN2		4	4	4	4	4	4	4	4	4	4	
3600918	02S/03W-01D01S	REDLANDS, CITY OF	W	1, REDLANDS HEIGHTS		364	373	321	381	401	368					
3600923	01N/03W-32C01S	CALIF DEPT OF MENTAL HEALTH- PLANT OPERA	W	PATTON 1	1972	0	0	0	0	0	0	0	0	0	0	
3600924	01N/03W-29M01S	CALIF DEPT OF MENTAL HEALTH- PLANT OPERA	W	PATTON 2	1978	0	0	0	0	0	0	0	0	0	0	
3600924-	01N/03W-29M	CALIF DEPT OF MENTAL HEALTH- PLANT OPERA	W	2A		155	25	1	5	11	39					
3600925	01S/04W-01Q01S	EAST VALLEY WATER DISTRICT	W	PL 100	2003	0	0	0	0	0	0	0	0	0	0	
3600926	01S/04W-01F02S	EAST VALLEY WATER DISTRICT	W	PL 115	2003	0	0	0	0	0	0	0	0	0	0	
3600927	01N/03W-31B01S	EAST VALLEY WATER DISTRICT	W	PL 116	2003	0	0	0	0	0	0	0	0	0	0	
3600928	01N/03W-31L02S	EAST VALLEY WATER DISTRICT	W	PL 117	2003	0	0	0	0	0	0	0	0	0	0	
3600929	01N/03W-31K02S	CALIF DEPT OF MENTAL HEALTH- PLANT OPERA	W	PATTON 8	1967	0	0	0	0	0	0	0	0	0	0	
3600930	01N/03W-31L03S	EAST VALLEY WATER DISTRICT	W	PL 118	2003	0	0	0	0	0	0	0	0	0	0	

**WESTERN - SAN BERNARDINO WATERMASTER
VERIFIED PRODUCTION DATA - NON PLAINTIFFS
CROSS INDEX BY RECORDATION NUMBER
SAN BERNARDINO BASIN**

RECRD TN NUMBER	STATE WELL NUMBER	OWNER	PLANT OPERA	WELL TYPE	LOCAL DESIGNATION	YEAR CLOSED	-----CALENDAR YEAR EXTRACTATIONS-----									
							2008	2009	2010	2011	2012	AVG				
3600931	01N/03W-29N01S	CALIF DEPT OF MENTAL HEALTH-	NORTH SIDE WATER COMPANY	W	PATTON10	1978	0	0	0	0	0	0	0	0	0	
3600933	01S/03W-23F	NORTH SIDE WATER COMPANY	TRI-CITY CONCRETE	W	WILSON 2	1978	0	0	0	0	0	0	0	0	0	
3600935	01N/04W-31N	TRI-CITY CONCRETE	EAST VALLEY WATER DISTRICT	W	PL 57	2000	0	0	0	0	0	0	0	0	0	
3600970	01N/03W-19G	EAST VALLEY WATER DISTRICT	EAST VALLEY WATER DISTRICT	W	PL 58/LT SAND CK	2000	0	0	0	0	0	0	0	0	0	
3600971	01N/03W-19F	EAST VALLEY WATER DISTRICT	CARDIFF FARMS MUTUAL WATER COMPANY	W	1	1991	0	0	0	0	0	0	0	0	0	
3600973	01S/04W-12D	CARDIFF FARMS MUTUAL WATER COMPANY	REYNOLDS, BILL	W		1957	0	0	0	0	0	0	0	0	0	
3600981	01S/02W-21H01S	REYNOLDS, BILL	WEST VALLEY WATER DIST	W	#08 / LORD 1	2003	0	0	0	0	0	0	0	0	0	
3600996	01N/05W-36J03S	WEST VALLEY WATER DIST	WEST VALLEY WATER DIST	W	#07 / LORD #7	1,631	1,203	125	8	98	613	0	0	0	0	
3600997	01N/05W-36H04S	WEST VALLEY WATER DIST	WEST VALLEY WATER DIST	W	#06 / FERG 1	1973	0	0	0	0	0	0	0	0	0	
3600998	01N/05W-25E02S	WEST VALLEY WATER DIST	WEST VALLEY WATER DIST	W	DIXON 1	1973	0	0	0	0	0	0	0	0	0	
3600999	01S/04W-06J01S	WEST VALLEY WATER DIST	WEST VALLEY WATER DIST	W	#12 / DIXON 2	1967	0	0	0	0	0	0	0	0	0	
3601000	01S/04W-06J02S	WEST VALLEY WATER DIST	WEST VALLEY WATER DIST	W	#09 / RAYNOR 1	1973	0	0	0	0	0	0	0	0	0	
3601002	01N/04W-31P03S	WEST VALLEY WATER DIST	WEST VALLEY WATER DIST	W	#13 / RAYNOR 4	1977	0	0	0	0	0	0	0	0	0	
3601003	01S/04W-06H02S	WEST VALLEY WATER DIST	MOUNTAIN VIEW POWER CO.	W	STM PL 1	1977	0	0	0	0	0	0	0	0	0	
3601012	01S/04W-08R	MOUNTAIN VIEW POWER CO.	MOUNTAIN VIEW POWER CO.	W	STM PL 2	1977	0	0	0	0	0	0	0	0	0	
3601013	01S/04W-08R	MOUNTAIN VIEW POWER CO.	MOUNTAIN VIEW POWER CO.	W	MTN. VIEW STPM 66	389	103	260	256	403	282	0	0	0	0	
3601014	01S/03W-18N03S	MOUNTAIN VIEW POWER CO.	MOUNTAIN VIEW POWER CO.	W	MT VIEW STMP2 #67	89	257	131	64	10	110	0	0	0	0	
3601015	01S/03W-18N02S	MOUNTAIN VIEW POWER CO.	MOUNTAIN VIEW POWER CO.	W	THORN 1	1977	0	0	0	0	0	0	0	0	0	
3601016	01S/04W-22G01S	MOUNTAIN VIEW POWER CO.	RAMIREZ, J. J.	W	STOWE	1956	0	0	0	0	0	0	0	0	0	
3601046	01S/03W-21A	RAMIREZ, J. J.	RAMIREZ, J. J.	W	STOWE	2007	0	0	0	0	0	0	0	0	0	
3601046-	01S/03W-21A	RAMIREZ, J. J.	RAMIREZ, J. J.	W	STOWE	2007	0	0	0	0	0	0	0	0	0	
3601069	01N/03W-33M02S	EAST VALLEY WATER DISTRICT	EAST VALLEY WATER DISTRICT	W	CHURCH	1987	0	0	0	0	0	0	0	0	0	
3601084	01S/02W-20K	SOUZA, JOHN	SOUZA, JOHN	W		1980	0	0	0	0	0	0	0	0	0	
3601085	01N/04W-31N02S	RIALTO, CITY OF	RIALTO, CITY OF	W	CITY 4 / #1	1992	0	0	0	0	0	0	0	0	0	
3601092	01S/03W-28D01S	KANSAS STREET MUTUAL WATER COMPANY	KANSAS STREET MUTUAL WATER COMPANY	W	KANSAS	0	0	0	0	0	0	0	0	0	0	
3601093	01N/04W-24H	SOMERS, R.	SOMERS, R.	D	SPRING	1974	0	0	0	0	0	0	0	0	0	
3601099	01S/03W-22F	PENN WELL COMPANY	PENN WELL COMPANY	W	1	1957	0	0	0	0	0	0	0	0	0	
3601102	01S/03W-21E	MAJESTIC MANAGEMENT	MAJESTIC MANAGEMENT	W	2 / MASCART	2007	0	0	0	0	0	0	0	0	0	
3601114	01N/04W-35C01S	SAN BERNARDINO, CITY OF	SAN BERNARDINO, CITY OF	W	PERRIS HILL 2	1981	0	0	0	0	0	0	0	0	0	
3601115	01N/04W-26P03S	SAN BERNARDINO, CITY OF	SAN BERNARDINO, CITY OF	W	PERRIS HILL 5	1	1	1	1	0	0	0	0	0	1	
3601116	01N/04W-35C02S	SAN BERNARDINO, CITY OF	SAN BERNARDINO, CITY OF	W	PERRIS HILL 3	2007	0	0	0	0	0	0	0	0	0	
3601117	01N/04W-35C03S	SAN BERNARDINO, CITY OF	SAN BERNARDINO, CITY OF	W	PERRIS HILL 4	0	0	0	0	0	0	0	0	0	0	
3601121	01S/02W-31F	7TH AVE WELL	7TH AVE WELL	W	1	1979	0	0	0	0	0	0	0	0	0	
3601126	01S/02W-30H	GAY GROVE	GAY GROVE	W	1	40	55	39	32	38	41	0	0	0	0	
3601130	01S/03W-32D	SAN BERNARDINO COUNTY FLOOD CONTROL	SAN BERNARDINO COUNTY FLOOD CONTROL	W	NICK'S WELL	149	190	189	0	0	106	0	0	0	0	
3601131	01S/03W-30K	FRINK RANCH	FRINK RANCH	W	1	1958	0	0	0	0	0	0	0	0	0	
3601161	01S/03W-16L	TENNESSEE MUTUAL WELL COMPANY	TENNESSEE MUTUAL WELL COMPANY	W	PIONEER 1	208	212	173	178	178	190	0	0	0	0	

**WESTERN - SAN BERNARDINO WATERMASTER
VERIFIED PRODUCTION DATA - NON PLAINTIFFS
CROSS INDEX BY RECORDATION NUMBER
SAN BERNARDINO BASIN**

RECRD TN NUMBER	STATE WELL NUMBER	OWNER	WELL TYPE	LOCAL DESIGNATION	YEAR CLOSED	2008	2009	2010	2011	2012	AVG
3601168	01S/04W-26F	UNGER, V. E.	W		1977	0	0	0	0	0	0
3601171	01S/03W-20F	SAN BERNARDINO COUNTY - FACILITY MANAGE	W	1/CRIM	2007	0	0	0	0	0	0
3601172	01S/03W-20C	K INV/ EVCA/ Y UN WELL	W		2007	0	0	0	0	0	0
3601173	01S/03W-32K	SOJKA, DONALD R.	W		1980	0	0	0	0	0	0
3601184	01N/03W-33F01S	EAST VALLEY WATER DISTRICT	W	PL 94 / CORWIN		0	0	0	0	0	0
3601186	01N/04W-36F03S	CONEJO RANCHOS MUTUAL WATER COMPANY	W	1	1957	0	0	0	0	0	0
3601250	01S/04W-08F10S	COLTON, CITY OF	W	4	1982	0	0	0	0	0	0
3601251	01S/04W-08R05S	COLTON, CITY OF	W	5	2002	0	0	0	0	0	0
3601252	01S/04W-05R	COLTON, CITY OF	W	6	1972	0	0	0	0	0	0
3601253	01S/04W-08Q01S	COLTON, CITY OF	W	7		0	0	0	0	0	0
3601254	01S/04W-08F08S	COLTON, CITY OF	W	8		0	0	0	0	0	0
3601256	01S/04W-09N	COLTON, CITY OF	W	PLUNGE12	1980	0	0	0	0	0	0
3601257	01S/04W-08F07S	COLTON, CITY OF	W	13		804	677	781	876	656	759
3601258	01S/04W-08R	COLTON, CITY OF	W	14	2002	0	0	0	0	0	0
3601260	01S/04W-08F01S	COLTON, CITY OF	W	16		449	0	287	656	836	446
3601262	01S/04W-08C02S	COLTON, CITY OF	W	BARNHL 18	1980	0	0	0	0	0	0
3601263	01N/05W-23Q01S	RIALTO, CITY OF	W	CITY #1		241	1	0	0	0	48
3601280	01S/03W-29D	YAHIKU, PAUL	W	SOUTH 1	1981	0	0	0	0	0	0
3601281	01S/02W-21M01S	REDLANDS, CITY OF	W	MAGUET #1		0	0	0	0	0	0
3601282	01S/01W-08H01S	REDLANDS, CITY OF	W	MILL CREEK #1		0	0	0	0	0	0
3601283	01S/02W-22C02S	REDLANDS, CITY OF	W	EAST LUGONIA #2		0	0	0	0	0	0
3601284	01S/02W-21E01S	REDLANDS, CITY OF	W	MAGUET #2		0	0	0	0	0	5
3601285	01S/01W-10L01S	REDLANDS, CITY OF	W	MILL CREEK #2		2,096	1,399	2,537	2,403	2,349	2,157
3601286	01S/02W-21E02S	REDLANDS, CITY OF	W	MAGUET #3	1981	0	0	0	0	0	0
3601287	01S/02W-21B02S	REDLANDS, CITY OF	W	EAST LUGONIA #3		8	83	167	52	18	66
3601288	01S/01W-11Q01S	REDLANDS, CITY OF	W	MILL CREEK #4		775	816	128	0	387	421
3601289	01S/03W-35E	REDLANDS, CITY OF	W	4R	1979	0	0	0	0	0	0
3601290	01S/02W-21D01S	REDLANDS, CITY OF	W	EAST LUGONIA #6		0	33	16	0	0	10
3601291	01S/03W-35G08S	REDLANDS, CITY OF	W	10		0	0	0	0	0	0
3601292	01S/03W-35G07S	REDLANDS, CITY OF	W	11		69	75	94	108	136	96
3601293	01S/03W-35H02S	REDLANDS, CITY OF	W	12		0	0	0	0	0	0
3601294	01S/03W-35G09S	REDLANDS, CITY OF	W	13	2006	0	0	0	0	0	0
3601295	01S/03W-35H04S	REDLANDS, CITY OF	W	14		0	0	0	0	0	0
3601296	01S/03W-35H03S	REDLANDS, CITY OF	W	16		694	1,141	473	22	0	466
3601297	01S/03W-35G11S	REDLANDS, CITY OF	W	17	2010	0	0	0	0	0	0
3601298	01S/03W-21H01S	REDLANDS, CITY OF	W	32		0	0	0	0	0	0
3601299	01S/04W-24K01S	REDLANDS, CITY OF	W	34		0	0	0	0	0	0

**WESTERN - SAN BERNARDINO WATERMASTER
VERIFIED PRODUCTION DATA - NON PLAINTIFFS
CROSS INDEX BY RECORDATION NUMBER
SAN BERNARDINO BASIN**

RECRD TN NUMBER	STATE WELL NUMBER	OWNER	WELL TYPE	LOCAL DESIGNATION	YEAR CLOSED	-----CALENDAR YEAR EXTRACTIONS-----										
						1988	2008	2009	2010	2011	2012	AVG				
3601300	01S/03W-27E02S	REDLANDS, CITY OF	W	40	1988	0	0	0	0	0	0	0	0	0	0	0
3601301	01S/03W-28H01S	REDLANDS, CITY OF	W	41		465	448	404	443	366	425					
3601302	01S/02W-14H	REDLANDS, CITY OF	D	COOLIE HAT - MILL CK		12,332	7,785	10,076	13,492	10,679	10,873					
3601308	01S/02W-19K01S	REDLANDS, CITY OF	W	AGATE 1		0	0	50	139	0	38					
3601309	01S/04W-05M	TRI-CITY CONCRETE	W	PLANT	1979	0	0	0	0	0	0					
3601316	01S/04W-23N	SAN BERNARDINO, CITY OF	W	INTERCITY MUTUAL 08		0	0	0	0	0	0					
3601352	01S/03W-19N	GENERAL AMERICAN LIFE	W	LANGFORD		62	62	62	62	62	62					
3601376	01N/04W-14C	LULY, LUCIAN L	D	WATERMAN	1960	0	0	0	0	0	0					
3601377	01N/04W-14C	LULY, LUCIAN L	D	WATERMAN	1960	0	0	0	0	0	0					
3601378	01N/04W-14C	LULY, LUCIAN L	D	WATERMAN	1960	0	0	0	0	0	0					
3601381	01N/05W-07C	NEALEY MUTUAL WATER COMPANY	D		1958	0	0	0	0	0	0					
3601384	01S/04W-25C	LOMA LINDA, CITY OF	W	1	1969	0	0	0	0	0	0					
3601388	01S/04W-25C	LOMA LINDA, CITY OF	W	COURT ST	1997	0	0	0	0	0	0					
3601405	01S/03W-22F	PENN WELL COMPANY	W	2	1981	0	0	0	0	0	0					
3601420	01S/03W-09E	CEMEX CONSTRUCTION MATERIALS PACIFIC, LL	W	ALABAMA 2		184	174	174	174	174	184					
3601451	01S/02W-32G01S	KOCH, GEORGE J.	W	1	1962	0	0	0	0	0	0					
3601497	01N/05W-23H01S	MUSCOY MUTUAL WATER COMPANY NO. 1	W	MUSCOY 1		460	1,203	379	318	375	547					
3601498	01N/05W-24D01S	MUSCOY MUTUAL WATER COMPANY NO. 1	W	LACY #5		375	317	450	308	308	352					
3601499	01N/05W-23A01S	MUSCOY MUTUAL WATER COMPANY NO. 1	W	MUSCOY 2		463	80	314	413	393	333					
3601500	01N/05W-23A02S	MUSCOY MUTUAL WATER COMPANY NO. 1	W	MUSCOY 3		463	87	322	416	453	348					
3601582	01S/04W-02R	EAST VALLEY WATER DISTRICT	W	PL 119	2003	0	0	0	0	0	0					
3601584	01N/03W-33H01S	EAST VALLEY WATER DISTRICT	W	PL 47	2003	0	0	0	0	0	0					
3601585	01S/03W-23A03S	BEAR VALLEY MUTUAL WATER COMPANY	W	SBDNO AV 1 NELSON		0	0	0	0	0	0					
3601586	01S/03W-15F01S	REDLANDS, CITY OF	W	ORANGE STREET		567	694	1,065	1,406	1,600	1,066					
3601588	01N/04W-31H	SAN BERNARDINO, CITY OF	W	STATE 1		0	0	0	0	0	0					
3601619	01S/04W-12D	CARDIFF FARMS MUTUAL WATER COMPANY	W	2	1991	0	0	0	0	0	0					
3601626	01S/04W-10D	SAN BERNARDINO, CITY OF	W	CITYLOTS	1969	0	0	0	0	0	0					
3601628	01S/02W-09Q	COGBILL, CLINTON L.	W	2		50	50	50	50	50	50					
3601629	01S/03W-03P	RIEDMAN, FRED M	W	1	1961	0	0	0	0	0	0					
3601631	01N/03W-34C02S	BRISTOL RANCH	W	1	1972	0	0	0	0	0	0					
3601632	02S/03W-05A02S	DEER PARK LLC	W	CLOCK CYN		0	0	0	0	0	0					
3601636	01S/04W-24R	REDLANDS, CITY OF	W	LANGFORD	1973	0	0	0	0	0	0					
3601637	01S/03W-30D	REDLANDS, CITY OF	W		1977	0	0	0	0	0	0					
3601639	01S/03W-03R02S	EAST VALLEY WATER DISTRICT	W	PL 146 / 2		218	184	308	336	178	245					
3601640	01S/02W-14N	SUNRISE RANCH PARTNERSHIP	W	SUN 6	1991	0	0	0	0	0	0					
3601641	01S/02W-30C01S	REDLANDS UNIFIED SCHOOL DISTRICT	W	OPAL ST		140	201	98	59	109	121					
3601642	01S/02W-30B02S	WESSON, ROBERT CRAIG	W	KING ST		8	8	4	14	14	10					

**WESTERN - SAN BERNARDINO WATERMASTER
VERIFIED PRODUCTION DATA - NON PLAINTIFFS
CROSS INDEX BY RECORDATION NUMBER
SAN BERNARDINO BASIN**

RECRD TN NUMBER	STATE WELL NUMBER	OWNER	WELL TYPE	LOCAL DESIGNATION	YEAR CLOSED	-----CALENDAR YEAR EXTRACTIONS-----										
						2008	2009	2010	2011	2012	AVG					
3601643	01S/03W-03R01S	EAST VALLEY WATER DISTRICT	W	PL 121	2003	0	0	0	0	0	0	0	0	0	0	
3601644	01S/03W-01A	NORTH FORK WATER COMPANY	W	PLUNGE CK	2000	0	0	0	0	0	0	0	0	0	0	
3601645	01S/02W-30B	HINCKLEY, HORACE P.	W	1	1982	0	0	0	0	0	0	0	0	0	0	
3601647	01S/03W-23A03S	JUDSON MUTUAL WATER COMPANY	W	1	1982	0	0	0	0	0	0	0	0	0	0	
3601649	01S/03W-28M	HOOVER WELL	W	HOOVER	1978	0	0	0	0	0	0	0	0	0	0	
3601649-	01S/03W-28M	RAMIREZ, J. J.	W	HOOVER		0	0	0	0	0	0	0	0	0	0	
3601653	01N/04W-36K04S	EAST VALLEY WATER DISTRICT	W	PL 1	2000	0	0	0	0	0	0	0	0	0	0	
3601654	01N/04W-36K	EAST VALLEY WATER DISTRICT	W	PL 1A / FISHER	2000	0	0	0	0	0	0	0	0	0	0	
3601655	01N/04W-36K05S	EAST VALLEY WATER DISTRICT	W	PL 2	2000	0	0	0	0	0	0	0	0	0	0	
3601656	01N/04W-36Q01S	EAST VALLEY WATER DISTRICT	W	PL 6	2003	0	0	0	0	0	0	0	0	0	0	
3601657	01S/04W-01B04S	EAST VALLEY WATER DISTRICT	W	PL 7	2000	0	0	0	0	0	0	0	0	0	0	
3601658	01N/04W-36R10S	EAST VALLEY WATER DISTRICT	W	PL 8	2003	0	0	0	0	0	0	0	0	0	0	
3601659	01S/03W-06H01S	EAST VALLEY WATER DISTRICT	W	PL 9	2000	0	0	0	0	0	0	0	0	0	0	
3601660	01S/03W-06H04S	EAST VALLEY WATER DISTRICT	W	PL 9A		1,224	737	934	813	683	878					
3601661	01S/04W-01J08S	EAST VALLEY WATER DISTRICT	W	PL 10	2003	0	0	0	0	0	0	0	0	0	0	
3601662	01S/04W-02Q05S	EAST VALLEY WATER DISTRICT	W	PL 11	2000	0	0	0	0	0	0	0	0	0	0	
3601663	01S/04W-02Q04S	EAST VALLEY WATER DISTRICT	W	PL 12		0	0	0	0	0	0	0	0	0	0	
3601664	01S/04W-02N01S	EAST VALLEY WATER DISTRICT	W	PL 13	2003	0	0	0	0	0	0	0	0	0	0	
3601665	01S/04W-01K04S	EAST VALLEY WATER DISTRICT	W	PL 14		0	0	0	0	0	0	0	0	0	0	
3601666	01N/04W-36F08S	EAST VALLEY WATER DISTRICT	W	PL 16	2003	0	0	0	0	0	0	0	0	0	0	
3601667	01S/03W-06A05S	EAST VALLEY WATER DISTRICT	W	PL 21	2000	0	0	0	0	0	0	0	0	0	0	
3601668	01S/04W-01E02S	EAST VALLEY WATER DISTRICT	W	PL 22	2000	0	0	0	0	0	0	0	0	0	0	
3601669	01N/04W-36H06S	EAST VALLEY WATER DISTRICT	W	PL 23	2000	0	0	0	0	0	0	0	0	0	0	
3601670	01N/04W-26A10S	EAST VALLEY WATER DISTRICT	W	PL 24	2000	0	0	0	0	0	0	0	0	0	0	
3601671	01N/04W-26A02S	EAST VALLEY WATER DISTRICT	W	PL 24A		415	330	416	1,063	784	602					
3601672	01N/04W-25B	EAST VALLEY WATER DISTRICT	W	PL 25	2000	0	0	0	0	0	0	0	0	0	0	
3601673	01N/04W-25C02S	EAST VALLEY WATER DISTRICT	W	PL 25A		250	128	333	646	790	429					
3601674	01N/04W-25G01S	EAST VALLEY WATER DISTRICT	W	PL 26	2003	0	0	0	0	0	0	0	0	0	0	
3601675	01N/04W-25A01S	EAST VALLEY WATER DISTRICT	W	PL 27		805	510	211	1	0	305					
3601676	01S/04W-12B05S	EAST VALLEY WATER DISTRICT	W	PL 28	2000	0	0	0	0	0	0	0	0	0	0	
3601677	01S/03W-05A02S	EAST VALLEY WATER DISTRICT	W	PL 31	2000	0	0	0	0	0	0	0	0	0	0	
3601678	01S/03W-05B04S	EAST VALLEY WATER DISTRICT	W	PL 32	2000	0	0	0	0	0	0	0	0	0	0	
3601679	01S/03W-05N05S	EAST VALLEY WATER DISTRICT	W	PL 38	2003	0	0	0	0	0	0	0	0	0	0	
3601684	01S/04W-08F06S	TERRACE WATER COMPANY	W	LARGE 1	1978	0	0	0	0	0	0	0	0	0	0	
3601684-	01S/04W-08F12S	TERRACE WATER COMPANY	W	#1 SMALL, 50 HP SUB		255	399	268	392	252	313					
3601685	01S/04W-08F14S	TERRACE WATER COMPANY	W	SMALL 2	1962	0	0	0	0	0	0	0	0	0	0	
3601686	01S/04W-08F14S	TERRACE WATER COMPANY	W	#2 LARGE WELL, 100HP		558	389	433	314	499	439					

**WESTERN - SAN BERNARDINO WATERMASTER
VERIFIED PRODUCTION DATA - NON PLAINTIFFS
CROSS INDEX BY RECORDATION NUMBER
SAN BERNARDINO BASIN**

RECRD TN NUMBER	STATE WELL NUMBER	OWNER	WELL TYPE	LOCAL DESIGNATION	YEAR CLOSED	-----CALENDAR YEAR EXTRACTIONS-----										
						D	FILTER	2008	2009	2010	2011	2012	AVG			
3601718	01N/05W-22M	RIALTO, CITY OF	D		1977			1,165	1,123	1,210	1,171	1,311	1,196			
3601725	01N/05W-25E	WEST VALLEY WATER DIST	D					0	0	0	0	0	0	0		
3601728	01S/03W-30K	RAMIREZ, J. J.	W	FRINK'S #1				0	0	0	0	0	0	0		
3601748	01S/03W-18H01S	BARTON DEVELOPMENT	W	CALIF	1978			0	0	0	0	0	0	0		
3601748	01S/03W-19A01S	BARTON DEVELOPMENT	W	CALIF	1996			0	0	0	0	0	0	0		
3601749	01S/03W-19B01S	MARIGOLD FARMS COMPANY	W	JAP	1974			0	0	0	0	0	0	0		
3601750	01S/03W-18L	SPRING PACIFIC PROPERTY LLC	W	ACQUIL/MARIGOLD	2004			0	0	0	0	0	0	0		
3601751	01S/03W-21E	RIVENDELL LAND COMPANY	W	ALABAMA/CHRISTINA				0	0	0	0	0	0	0		
3601753	01S/03W-29D	RANCHO CITRUS AMIGOS	W	PARK AVE 1	1971			0	0	0	0	0	0	0		
3601781	01S/03W-06K01S	EAST VALLEY WATER DISTRICT	W	PL35/BASELINE MUTUAL	2003			0	0	0	0	0	0	0		
3601809	01N/04W-26H	DEL ROSA MUTUAL WATER COMPANY	W	GOLDNAV1	1967			0	0	0	0	0	0	0		
3601810	01N/04W-23E	DEL ROSA MUTUAL WATER COMPANY	W	PRKSD 2	1981			0	0	0	0	0	0	0		
3601811	01N/04W-14A	CAMPUS CRUSADE FOR CHRIST	D	EAST TWIN				3	0	0	0	0	0	1		
3601823	01S/04W-23K	TRI-CITY MUTUAL WATER COMPANY	W		1964			0	0	0	0	0	0	0		
3601837	01N/03W-34B	SYCAMORE HEIGHTS WATER COMPANY INC	W	HERCULES	1962			0	0	0	0	0	0	0		
3601838	01N/03W-34A	SYCAMORE HEIGHTS WATER COMPANY INC	W	WALKISHA	1962			0	0	0	0	0	0	0		
3601839	01S/03W-10D01S	MCCALLA, ROBERT	W	1	2007			0	0	0	0	0	0	0		
3601843	01N/05W-03H01S	SAN BERNARDINO, CITY OF	W	CAJON NO 1				0	0	0	0	0	0	0		
3601844	01N/05W-03H02S	SAN BERNARDINO, CITY OF	W	CAJON NO 2				1,094	1,160	1,366	1,673	1,443	1,347			
3601845	01N/04W-30M01S	SAN BERNARDINO, CITY OF	W	MALLORY NO. 3				337	593	356	903	667	571			
3601848	01S/04W-05E05S	WEST VALLEY WATER DIST	W	#15.9TH & PENNSYLVAN				764	801	156	969	1,012	740			
3601878	01N/04W-29E01S	SAN BERNARDINO, CITY OF	W	DARBY				0	0	0	0	0	0	0		
3601879	01N/04W-29E	SAN BERNARDINO, CITY OF	W	GARDENA				0	0	0	0	0	0	0		
3601880	01N/04W-29F01S	SAN BERNARDINO, CITY OF	W	COLIMA	2007			0	0	0	0	0	0	0		
3601884	01N/03W-31C02S	EAST VALLEY WATER DISTRICT	W	PL 30	2000			0	0	0	0	0	0	0		
3601910	01S/03W-30L	LOMA LINDA UNIVERSITY	W	PUFFER	1975			0	0	0	0	0	0	0		
3601924	01S/04W-15D	NATIONAL ORANGE SHOW	W					20	50	1	50	62	37			
3601925	01N/04W-23E	ARROWHEAD COUNTRY CLUB	W	1				531	472	396	385	433	443			
3601929	01S/04W-06C04S	RIALTO, CITY OF	W	CITY #6				0	0	0	0	0	0	0		
3601930	01N/03W-32C02S	CALIF DEPT OF MENTAL HEALTH- PLANT OPERA	W	PATTON11	2009			0	0	0	0	0	0	0		
3601932	01S/03W-29B01S	IOWA STREET WELL	W		1974			0	0	0	0	0	0	0		
3601944	01N/05W-23Q01S	WEST VALLEY WATER DIST	W	#02 / LOWER 7				1,905	1,707	1,522	677	2,151	1,592			
3601969	01S/02W-14L	SUNRISE RANCH PARTNERSHIP	W	SUNRISE 7	1991			0	0	0	0	0	0	0		
3601978	01S/03W-04N01S	EAST VALLEY WATER DISTRICT	W	PL 40				0	0	0	0	0	0	0		
3601979	01N/04W-14A	CAMPUS CRUSADE FOR CHRIST	D	EAST TWIN	1981			0	0	0	0	0	0	0		
3601987	01S/03W-04G02S	EAST VALLEY WATER DISTRICT	W	PL 136 / DUNKIRK 1				0	0	0	0	0	0	0		
3601989	01S/04W-24R01S	LOMA LINDA, CITY OF	W	GOLCONDA	1974			0	0	0	0	0	0	0		

WESTERN - SAN BERNARDINO WATERMASTER
 VERIFIED PRODUCTION DATA - NON PLAINTIFFS
 CROSS INDEX BY RECORDATION NUMBER
 SAN BERNARDINO BASIN

RECRD TN NUMBER	STATE WELL NUMBER	OWNER	WELL TYPE	LOCAL DESIGNATION	YEAR CLOSED	-----CALENDAR YEAR EXTRACTATIONS-----											AVG				
						2008	2009	2010	2011	2012	2013	2014	2015	2016	2017	2018	2019	2020	2021	2022	
3602003	01S/02W-16C	SOLANO WELL NO 3	W	3		64	74	62	48	76											65
3602007	01S/04W-02K	BERMAN, BUD	W	2		5	0	0	0	0											1
3602008	01S/04W-26A	LOMA LINDA UNIVERSITY	W	1		0	0	0	0	0											0
3602009	01S/04W-25G01S	LOMA LINDA UNIVERSITY	W	3		0	0	0	0	0											0
3602010	01S/04W-25H02S	LOMA LINDA, CITY OF	W	VAN LEUVEN		0	0	0	0	0											0
3602011	01S/04W-25B02S	LOMA LINDA, CITY OF	W	DART		0	0	0	0	0											0
3602012	01S/04W-25C01S	LOMA LINDA UNIVERSITY	W	6		0	0	0	0	0											0
3602013	01S/04W-24N	LOMA LINDA UNIVERSITY	W	7		0	0	0	0	0											0
3602014	01S/04W-26J01S	LOMA LINDA UNIVERSITY	W	8		0	0	0	0	0											0
3602015	01S/04W-25B	LOMA LINDA, CITY OF	W	NIES		0	0	0	0	0											0
3602016	01S/04W-25G	LOMA LINDA, CITY OF	W	ROBINSON		0	0	0	0	0											0
3602017	01S/04W-25E01S	LOMA LINDA UNIVERSITY	W	2		0	0	0	0	0											0
3602020	01S/02W-20K	FAR WELL	W	F A R		74	70	29	0	0											35
3602031	01S/03W-21H06S	REDLANDS, CITY OF	W	30-A		207	257	360	616	304											349
3602032	01S/03W-22A02S	REDLANDS, CITY OF	W	35		0	0	0	0	0											0
3602034	01S/04W-01Q08S	EAST VALLEY WATER DISTRICT	W	PL 12A		210	2	1	1	1											43
3602036	01S/03W-21H07S	REDLANDS, CITY OF	W	31-A		0	0	0	0	0											21
3602057	01S/04W-25C	LOMA LINDA, CITY OF	W	MITTLEID		0	0	0	0	0											0
3602058	01S/04W-25F	LOMA LINDA, CITY OF	W	CROOKS		0	0	0	0	0											0
3602060	01S/04W-24P	SAN BERNARDINO, CITY OF	W	JOHANSSON, RUNE		0	0	0	0	0											0
3602062	01S/02W-29N	BUOYE WELL	W	1		0	0	0	0	0											0
3602065	01S/03W-32J02S	REDLANDS, CITY OF	W	LEE WELL		0	0	0	0	0											0
3602065-	01S/03W-32J02S	REDLANDS, CITY OF	W	LEE WELL		0	0	0	0	0											0
3602066	01S/04W-02B	SAN BERNARDINO, CITY OF	W	1, VAN LOON/BELVAN		0	0	0	0	0											0
3602067	01N/04W-35K	SAN BERNARDINO, CITY OF	W	2-GILBERT/CANYON RD		0	0	0	0	0											0
3602068	01S/04W-01A02S	ARROYO VERDE MUTUAL WATER COMPANY	W			0	0	0	0	0											0
3602069	01S/04W-01A	ARROYO VERDE MUTUAL WATER COMPANY	W			0	0	0	0	0											0
3602074	01N/03W-34B02S	TILDEN, M WILLIAM	W	IRRIG 1		0	0	0	0	0											0
3602075	01N/03W-34B01S	TILDEN, M WILLIAM	W	DOM 2		0	0	0	0	0											0
3602079	01S/03W-03F	BARNO, JOHN	W	1		0	0	0	0	0											0
3602080	01N/05W-23Q02S	RIALTO, CITY OF	W	CITY #2		2,565	1,961	2,102	1,336	842											1,761
3602081	01N/04W-27B01S	SAN BERNARDINO, CITY OF	W	31ST ST. & MT VIEW		298	361	141	240	205											249
3602082	02S/03W-03K01S	REDLANDS, CITY OF	W	36 (CEMETERY)		216	189	180	181	177											189
3602106	01S/03W-22A01S	REDLANDS, CITY OF	W			0	0	0	0	0											0
3602109	01S/03W-31B01S	REDLANDS, CITY OF	W	4, BRYN MAWR		0	0	0	0	0											0
3602112	01S/04W-13R01S	VICTORIA FARMS MUTUAL WATER CO	W			0	0	0	0	0											0
3602113	01N/03W-30N01S	EAST VALLEY WATER DISTRICT	W	PL 41		0	0	0	0	0											0

**WESTERN - SAN BERNARDINO WATERMASTER
VERIFIED PRODUCTION DATA - NON PLAINTIFFS
CROSS INDEX BY RECORDATION NUMBER
SAN BERNARDINO BASIN**

RECRD TN NUMBER	STATE WELL NUMBER	OWNER	WELL TYPE	LOCAL DESIGNATION	YEAR CLOSED	-----CALENDAR YEAR EXTRACTIONS-----					AVG
						2008	2009	2010	2011	2012	
3602119	01S/03W-33C01S	LAKESIDE AVENUE MUTUAL WELL COMPANY	W	REDLANDS	1974	0	0	0	0	0	0
3602122	01S/04W-23R03S	SAN BERNARDINO, CITY OF	W	ROSEWOOD	1966	0	0	0	0	0	0
3602123	01S/04W-14J	SAN BERNARDINO, CITY OF	W	NORMAN RD		0	0	0	0	0	0
3602124	01S/04W-14J	SAN BERNARDINO, CITY OF	W	CENTRAL AVE	1984	0	0	0	0	0	0
3602125	01S/04W-24F04S	SAN BERNARDINO, CITY OF	W	GOULD #1 OLD	2007	0	0	0	0	0	0
3602126	01S/04W-24F	SAN BERNARDINO, CITY OF	W	GOULD #2 NEW	2007	0	0	0	0	0	0
3602127	01S/03W-15A01S	GOLDEN BEAR FOREST PRODUCTS	W	1	1991	0	0	0	0	0	0
3602128	01S/04W-14A	SAN BERNARDINO, CITY OF	W	GIFFORD PK/ #1	2007	0	0	0	0	0	0
3602130	01S/04W-01P01S	EASTWOOD FARMS COMMUNITY WATER USERS	W	1	2002	0	0	0	0	0	0
3602131	01S/04W-01P02S	EASTWOOD FARMS COMMUNITY WATER USERS	W	2	2002	0	0	0	0	0	0
3602170	01S/02W-31M	ROBBINS, H W	W			5	5	5	5	5	5
3602171	01S/02W-18M	REES & PERRICONE RANCH	W	1	1981	0	0	0	0	0	0
3602174	01S/04W-02A05S	EAST VALLEY WATER DISTRICT	W	PL 105 / MYERS	2000	0	0	0	0	0	0
3602186	01S/02W-21L02S	CRAFTON WATER COMPANY	W	2-GARNET/ZANJA		0	0	0	0	0	0
3602188	01S/02W-29L	DANGERMOND, JACK	W	RANCHO LADERA-ESRI		215	333	0	0	0	110
3602193	01S/03W-14R01S	RAUGHT MUTUAL WELL COMPANY	W	RAUGHT		204	248	215	239	255	232
3602205	01N/04W-06H01S	SAN BERNARDINO, CITY OF	W	DEVIL CANYON #4		28	13	4	5	3	11
3602206	01N/04W-06H02S	SAN BERNARDINO, CITY OF	W	DEVIL CANYON #3		141	56	9	0	1	41
3602211	01S/03W-26C01S	REDLANDS, CITY OF	W	37 SYLVAN PARK		0	0	0	0	0	0
3602224	01S/03W-13P	EAST PIONEER MUTUAL WELL COMPANY	W		1991	0	0	0	0	0	0
3602241	01S/03W-20F03S	CARTER, JAMES	W	ALMOND	2007	0	0	0	0	0	0
3602247	01S/04W-13R03S	VICTORIA FARMS MUTUAL WATER CO	W	2	1981	0	0	0	0	0	0
3602249	01S/04W-25D05S	LOMA LINDA UNIVERSITY	W	ANDERSON	1985	0	0	0	0	0	0
3602252	01S/04W-14B03S	SAN BERNARDINO, CITY OF	W	2	1977	0	0	0	0	0	0
3602260	01S/03W-05D06S	EAST VALLEY WATER DISTRICT	W	PL 132 / CULL#3	2004	0	0	0	0	0	0
3602264	01N/04W-27N01S	SAN BERNARDINO, CITY OF	W	23RD ST.	2010	0	0	0	0	0	0
3602265	01S/04W-03J05S	SAN BERNARDINO, CITY OF	W	7TH ST.		140	226	79	165	216	165
3602274	01N/03W-30J05S	EAST VALLEY WATER DISTRICT	W	PL 39		921	1,084	937	1,086	896	985
3602280	01S/02W-18Q	MENTONE CITRUS GROWERS	W	#2		518	587	531	802	871	662
3602285	01S/04W-15D05S	SAN BERNARDINO, CITY OF	W	15D5	1979	0	0	0	0	0	0
3602320-	01S/03W-16L	NEW ENGLAND WATER COMPANY	W			229	250	200	195	360	247
3602337	01N/04W-26A03S	EAST VALLEY WATER DISTRICT	W	PL 24B		1,818	1,355	398	46	1,683	1,060
3602338	01S/03W-04N03S	EAST VALLEY WATER DISTRICT	W	PL 40A		0	23	1,009	441	499	394
3602345	01N/05W-24E01S	MUSCOY MUTUAL WATER COMPANY NO. 1	W	MUSCOY 4		203	40	161	236	222	172
3602346	01S/03W-28K01S	REDLANDS, CITY OF	W	NEW YORK ST. WELL		1,217	1,009	1,000	945	843	1,003
3602351	01S/02W-13A01S	REDLANDS, CITY OF	W	MILL CREEK O-A		1	0	0	0	0	0
3602370	01N/04W-25C04S	EAST VALLEY WATER DISTRICT	W	PL 107		499	1,342	1,399	926	954	1,024

**WESTERN - SAN BERNARDINO WATERMASTER
VERIFIED PRODUCTION DATA - NON PLAINTIFFS
CROSS INDEX BY RECORDATION NUMBER
SAN BERNARDINO BASIN**

RECRD TN NUMBER	STATE WELL NUMBER	OWNER	WELL TYPE	LOCAL DESIGNATION	YEAR CLOSED	-----CALENDAR YEAR EXTRACTS-----										
						2008	2009	2010	2011	2012	AVG					
3602381	01N/03W-29M	CALIF DEPT OF MENTAL HEALTH- PLANT OPERA	W	14	1957	43	28	0	0	0	0	0	0	14		
3602382	02N/05W-28D	DEVORE WATER COMPANY	W	1	1957	0	0	0	0	0	0	0	0	0		
3602383	02N/05W-28C02S	DEVORE WATER COMPANY	W	2A	1957	118	137	62	71	131	104	104	104	104		
3602384	02N/05W-28C03S	DEVORE WATER COMPANY	W	3	1957	93	111	69	0	121	79	79	79	79		
3602385	02N/05W-20H	DEVORE WATER COMPANY	W	MIDDLEMAN FALLS CK	1957	9	8	8	9	11	9	9	9	9		
3602386	02N/05W-21E	DEVORE WATER COMPANY	W	LETHIN SP	1957	46	31	53	66	50	49	49	49	49		
3602387	02N/05W-22E	DEVORE WATER COMPANY	D	E KIMBARK	1957	68	48	61	75	35	57	57	57	57		
3602388	02N/05W-21G	DEVORE WATER COMPANY	W	KIMBARK	1957	241	171	292	337	155	239	239	239	239		
3602389	02N/05W-22N	DEVORE WATER COMPANY	D	HOPPER	1968	0	0	0	0	0	0	0	0	0		
3602390	02N/05W-28B	DEVORE WATER COMPANY	D	SANTA FE	1968	0	0	0	0	0	0	0	0	0		
3602391	02N/05W-28D	DEVORE WATER COMPANY	D	CASADY	1968	0	0	0	0	0	0	0	0	0		
3602399	01N/04W-16E04S	SAN BERNARDINO, CITY OF	W	NEWMARK #4	1968	1,554	366	901	1,527	1,573	1,184	1,184	1,184	1,184		
3602400	01N/04W-32N01S	SAN BERNARDINO, CITY OF	W	BASELINE & CALIFORNI	1968	339	347	160	172	102	224	224	224	224		
3602401	01N/04W-27A02S	SAN BERNARDINO, CITY OF	W	LEROY	1968	822	883	335	579	612	646	646	646	646		
3602405	01S/04W-08C04S	COLTON, CITY OF	W	19	1968	997	1,103	554	897	884	887	887	887	887		
3602417	01S/03W-05D07S	EAST VALLEY WATER DISTRICT	W	PL 132 / CULL #4	2004	0	0	0	0	0	0	0	0	0		
3602422	01S/04W-02K08S	SAN BERNARDINO, CITY OF	W	ANTIL 6	2004	0	81	5	27	0	23	23	23	23		
3602426	02N/05W-19Q01S	SAN BERNARDINO, CITY OF	D	VINCENT (CAJON CRK)	2004	498	403	521	724	546	538	538	538	538		
3602428	02N/05W-33E01S	DEVORE WATER COMPANY	W	4	2004	31	36	25	22	32	29	29	29	29		
3602474	01N/03W-25Q	EAST HIGHLAND RANCH	D	PLUNGE/BOX SPRING	2004	0	0	0	0	0	0	0	0	0		
3602498	01S/04W-08R07S	COLTON, CITY OF	W	NO 6B	2002	0	0	0	0	0	0	0	0	0		
3602499	01S/04W-22A01S	J. G. GOLFING ENTERPRISES	W	PAYNE H 25	2002	206	251	304	196	192	230	230	230	230		
3602521	01S/04W-23N04S	SAN BERNARDINO, CITY OF	W	NO 2	1977	0	0	0	0	0	0	0	0	0		
3602525	01S/03W-13C	L P R ICE COMPANY WELL	W	LPR ICE CO	1991	0	0	0	0	0	0	0	0	0		
3602528	01N/04W-35R01S	BASELINE GARDENS MUTUAL WATER COMPANY	W	#3-7251 BARTON ST	2013	424	336	217	0	0	195	195	195	195		
3602529	01S/02W-09P02S	BLUE GOOSE GROWERS INC	W	GRNSPOT 6	1980	0	0	0	0	0	0	0	0	0		
3602530	01S/02W-09L02S	BLUE GOOSE GROWERS INC	W	BLOCK 11	1980	0	0	0	0	0	0	0	0	0		
3602531	01S/02W-09L03S	BLUE BANNER COMPANY	W	TUNNEL DIV	1980	100	100	100	100	50	90	90	90	90		
3602549	01S/03W-19J07S	PHARAOSHS LOST KINDGOM	W	CALIF ST	2006	50	50	50	33	30	43	43	43	43		
3602550	01S/03W-17R04S	DANIELS RANCH	W	ALABAMA ST	2006	0	0	0	0	0	0	0	0	0		
3602560	01S/03W-04G03S	EAST VALLEY WATER DISTRICT	W	PL 136 / DUNKIRK#2	2006	0	0	0	0	0	0	0	0	0		
3602563	01S/04W-02Q10S	EAST VALLEY WATER DISTRICT	W	PL 11A	2006	1,546	1,911	1,629	1,288	1,028	1,480	1,480	1,480	1,480		
3602564	01S/04W-12B07S	EAST VALLEY WATER DISTRICT	W	PL 28A	2006	2,560	2,491	2,429	1,623	1,445	2,110	2,110	2,110	2,110		
3602571	01S/03W-03F02S	EAST VALLEY WATER DISTRICT	W	PL 122	2000	0	0	0	0	0	0	0	0	0		
3602574	01S/04W-13R04S	VICTORIA FARMS MUTUAL WATER CO	W	NO. 3	1999	0	0	0	0	0	0	0	0	0		
3602596	01S/04W-24R07S	LOMA LINDA, CITY OF	W	NEW GOLCONDA	1978	0	0	0	0	0	0	0	0	0		
3602653	01S/02W-19J01S	REDLANDS, CITY OF	W	2	1979	0	0	0	0	0	0	0	0	0		

**WESTERN - SAN BERNARDINO WATERMASTER
VERIFIED PRODUCTION DATA - NON PLAINTIFFS
CROSS INDEX BY RECORDATION NUMBER
SAN BERNARDINO BASIN**

RECRD TN NUMBER	STATE WELL NUMBER	OWNER	WELL TYPE	LOCAL DESIGNATION	YEAR CLOSED	-----CALENDAR YEAR EXTRACTIONS-----										
						2008	2009	2010	2011	2012	AVG					
3602654	01S/02W-19J02S	REDLANDS, CITY OF	W	CRAFTON		421	514	342	144	392	363					
3602657	01S/01W-20D01S	YUCAIPA VALLEY WATER DISTRICT	W	WELL NO 31	1980	0	0	0	0	0	0					
3602658	01S/01W-20D03S	YUCAIPA VALLEY WATER DISTRICT	W	WELL NO 32	1980	0	0	0	0	0	0					
3602659	01S/01W-19B02S	YUCAIPA VALLEY WATER DISTRICT	W	WELL NO 33	1997	0	0	0	0	0	0					
3602664	01N/05W-06M01S	STORKSON, DAVID D.	W	SPRING NO 1		35	31	28	26	30	30					
3602712	01N/04W-08P01S	CALIFORNIA STATE UNIVERSITY, SAN BERNARDI	W	ELLENA BROS.		0	0	0	0	0	0					
3602714	01S/04W-13R01S	VICTORIA FARMS MUTUAL WATER CO	W	NO 1	1999	0	0	0	0	0	0					
3602727	01N/05W-15Q02S	FONTANA UNION WATER COMPANY	W	FU 8		1,165	106	1	595	1,054	584					
3602759	01S/04W-24A01S	LOMA LINDA, CITY OF	W	MT VIEW 1	1999	0	0	0	0	0	0					
3602760	01S/04W-24B01S	LOMA LINDA, CITY OF	W	MT VIEW 2	2000	0	0	0	0	0	0					
3602766	01S/04W-06H03S	WEST VALLEY WATER DIST	W	#30 WASHINGTON/BSLIN		930	459	616	366	669	608					
3602781	01S/04W-25D06S	LOMA LINDA UNIVERSITY	W	ANDERSON II		92	89	138	67	64	90					
3602791	01S/02W-20B01S	REDLANDS, CITY OF	W	EAST LUGONIA #4		0	0	88	0	0	18					
3602792	01S/02W-19A01S	REDLANDS, CITY OF	W	AGATE #2		1,551	1,910	1,199	83	278	1,004					
3602793	01S/04W-08F15S	COLTON, CITY OF	W	WELL 21		1,797	1,816	1,032	1,438	1,879	1,592					
3602799	01S/02W-07F01S	EAST VALLEY WATER DISTRICT	W	PL 125		1,134	965	845	1,412	1,447	1,161					
3602821	01N/05W-03A02S	SAN BERNARDINO, CITY OF	W	CAJON #3		954	823	578	696	946	799					
3602844	01N/04W-08M02S	SAN BERNARDINO, CITY OF	W	DEVIL CANYON #5		272	458	282	148	210	274					
3602846	01S/04W-22A01S	J. G. GOLFING ENTERPRISES	W	THORN 10 & 11		469	319	282	394	439	381					
3602848	01N/05W-36B01S	RIALTO, CITY OF	W	CITY #3		147	23	33	0	24	45					
3602855	01S/04W-25D07S	LOMA LINDA UNIVERSITY	W	ANDERSON III		1,308	1,270	1,155	1,276	1,353	1,272					
3602895	01S/03W-13H02S	REDLANDS, CITY OF	W	AIRPORT #1		1,369	1,285	1,426	1,367	1,695	1,428					
3602896	01S/02W-20D01S	REDLANDS, CITY OF	W	MADEIRA		667	626	555	555	32	487					
3602897	01N/05W-23P	WEST VALLEY WATER DIST	W	#34 GOLF COURSE	2008	0	0	0	0	0	0					
3602917	01S/03W-33D01S	BROOKSIDE PLAZA	W	STATER BROS PLAZA		14	14	13	7	13	12					
3603027	01N/05W-36J01S	SAN BERNARDINO, CITY OF	W	LYTLE CK #2		652	659	500	737	622	634					
3603030	01S/04W-06B01S	RIALTO, CITY OF	W	CITY #5		0	0	0	0	0	0					
3603045	01S/01W-09J01S	REDLANDS, CITY OF	W	MILL CK #2A		0	256	9	0	0	53					
3603054	01N/05W-25E03S	WEST VALLEY WATER DIST	W	#35 GOLF COURSE	2003	0	0	0	0	0	0					
3603055	01N/05W-36H05S	WEST VALLEY WATER DIST	W	#36 LORD RANCH		0	0	0	0	0	0					
3603057	01S/04W-24C01S	LOMA LINDA, CITY OF	W	RICHARDSON #1		422	323	56	0	0	160					
3603058	01S/04W-24C02S	LOMA LINDA, CITY OF	W	RICHARDSON # 2	2001	0	0	0	0	0	0					
3603116	01S/03W-13Q01S	SAN BERNARDINO VALLEY M.W.D.	W	SB AVE #1/BIG BEAR		761	462	291	618	875	601					
3603141	01S/04W-04E01S	SAN BERNARDINO VALLEY M.W.D.	W	9TH ST.	2011	0	0	0	0	0	0					
3603174	01S/04W-04F02S	SAN BERNARDINO VALLEY M.W.D.	W	PERRIS ST		0	0	0	0	0	0					
3603206	01S/04W-04D02S	SAN BERNARDINO, CITY OF	W	OLIVE/GARNER		1,306	1,194	1,225	1,739	1,113	1,315					
3603207	01S/04W-04B04S	SAN BERNARDINO, CITY OF	W	10TH & J ST		1,620	2,075	1,797	2,507	1,723	1,944					

**WESTERN - SAN BERNARDINO WATERMASTER
VERIFIED PRODUCTION DATA - NON PLAINTIFFS
CROSS INDEX BY RECORDATION NUMBER
SAN BERNARDINO BASIN**

RECRD TN NUMBER	STATE WELL NUMBER	OWNER	WELL TYPE	LOCAL DESIGNATION	YEAR CLOSED	2008	2009	2010	2011	2012	AVG
3603208	01N/04W-34G04	SAN BERNARDINO, CITY OF	W	17TH ST. & SIERRA #2		282	76	279	17	16	134
3603247	01S/03W-06P18S	EAST VALLEY WATER DISTRICT	W	PL 141		1,653	808	1,056	1,535	1,668	1,344
3603262	01N/04W-31M03S	HOLLIDAY TRUCKING	W	SB #1		59	61	59	60	60	60
3603471	02N/05W-19R04S	SAN BERNARDINO, CITY OF	W	KENWOOD #1		1,166	1,132	1,423	1,770	1,400	1,378
3603472	01N/04W-14P03S	SAN BERNARDINO, CITY OF	W	40TH & VALENCIA		67	21	217	141	181	125
3603523	01S/04W-24P04S	LOMA LINDA, CITY OF	W	RICHARDSON #3		1,503	1,546	1,046	978	951	1,205
3603538	01S/04W-06H04S	RIALTO, CITY OF	W	CITY #4A		2,427	2,605	1,980	870	932	1,763
3603539	01S/02W-24C01S	YUCAIPA VALLEY WATER DISTRICT	W	YVWD 51/MILL CREEK		161	99	166	97	120	129
3603554	01S/03W-19A01S	BARTON DEVELOPMENT C/O LUCKY FARMS	W	CALIF ST		379	215	345	336	194	294
3603579	01N/04W-06A02S	SAN BERNARDINO, CITY OF	W	DEVIL CYN #7		92	66	67	77	81	77
3603580	01N/04W-06A01S	SAN BERNARDINO, CITY OF	W	DEVIL CYN #6		194	182	176	201	196	190
3603581	01S/04W-22C05S	SAN BERNARDINO, CITY OF	W	CENTURY		950	830	895	541	355	714
3603582	01S/04W-15P05S	SAN BERNARDINO, CITY OF	W	CHANDLER		800	857	633	754	1,133	835
3603583	01S/03W-02N02S	EAST VALLEY WATER DISTRICT	W	PLANT 143		617	895	981	620	966	816
3603646	01S/03W-07D	INLAND VALLEY DEVELOPMENT AGENCY	W	NORTON #2A		0	0	0	0	0	0
3603647	01S/04W-12C01S	INLAND VALLEY DEVELOPMENT AGENCY	W	NORTON #3		0	0	0	0	0	0
3603648	01S/04W-12F	INLAND VALLEY DEVELOPMENT AGENCY	W	NORTON #5		0	0	0	0	0	0
3603649	01S/03W-07A06S	SAN BERNARDINO, CITY OF	W	IVDA 11 (NORTON #11)		70	101	61	59	84	75
3603650	01S/03W-18C	INLAND VALLEY DEVELOPMENT AGENCY	W	NORTON GOLF COURSE		75	0	0	0	0	15
3603653	01S/03W-10J	CEMEX CONSTRUCTION MATERIALS PACIFIC, LL	W	ORANGE STREET		127	79	12	0	0	44
3603655	01S/03W-29Q01S	REDLANDS, CITY OF	W	#38		1,701	1,646	1,897	2,037	1,809	1,818
3603656	01S/03W-14E01S	REDLANDS, CITY OF	W	CHURCH STREET		172	253	204	679	1,115	485
3603688	01S/04W-03D04S	SAN BERNARDINO, CITY OF	W	EPA #1		1,986	1,526	2,003	2,328	2,269	2,022
3603689	01S/04W-03C03S	SAN BERNARDINO, CITY OF	W	EPA #2		2,165	2,260	2,243	2,337	2,680	2,337
3603690	01S/04W-03C04S	SAN BERNARDINO, CITY OF	W	EPA #3		3,412	3,198	3,069	3,112	2,563	3,071
3603691	01S/04W-03B03S	SAN BERNARDINO, CITY OF	W	EPA #4		2,107	2,201	1,918	2,011	1,874	2,022
3603692	01S/04W-03A04S	SAN BERNARDINO, CITY OF	W	EPA #5		2,379	2,430	1,227	204	1,083	1,465
3603693	01N/04W-16M03S	SAN BERNARDINO, CITY OF	W	EPA #6		529	593	438	513	551	525
3603694	01N/04W-16M04S	SAN BERNARDINO, CITY OF	W	EPA #7		2,074	2,130	1,917	884	1,799	1,761
3603695	01N/05W-25Q	VULCAN - CAL MAT	W	HIGHLAND PLANT		863	0	0	0	0	173
3603696	01N/05W-02N	VULCAN - CAL MAT	W	CAJON CK AREA D		27	28	27	27	27	27
3603697	01N/05W-14A	VULCAN - CAL MAT	W	CAJON CK PLNG. "M"		196	196	103	107	92	139
3603698	02N/05W-27L	PAYNE, LARRY	W	OWNERS #1		40	1	1	1	1	9
3603699	02N/05W-27L02S	PAYNE, LARRY	W	OWNERS #2		0	1	1	1	1	1
3603700	02N/05W-27L03S	PAYNE, LARRY	W	OWNERS #3		0	0	0	0	0	0
3603704	01S/04W-08J02S	COLTON, CITY OF	W	26		551	609	468	735	648	602
3603719	01S/04W-24A05S	LOMA LINDA, CITY OF	W	MTN. VIEW #3		1,732	2,265	2,200	442	795	1,487

**WESTERN - SAN BERNARDINO WATERMASTER
VERIFIED PRODUCTION DATA - NON PLAINTIFFS
CROSS INDEX BY RECORDATION NUMBER
SAN BERNARDINO BASIN**

RECRD TN NUMBER	STATE WELL NUMBER	OWNER	WELL TYPE	LOCAL DESIGNATION	YEAR CLOSED	-----CALENDAR YEAR EXTRACTIONS-----										
						2008	2009	2010	2011	2012	AVG					
3603720	01S/04W-24F11S	LOMA LINDA, CITY OF	W	RICHARDSON #4		464	446	51	0	0	0	192				
3603721	01S/04W-24R08S	LOMA LINDA, CITY OF	W	MTN. VIEW #4		0	0	0	0	0	0	0				
3603734	01S/03W-02P06S	EAST VALLEY WATER DISTRICT	W	PLANT 147		1,768	1,539	1,738	2,004	1,717	1,753	1,753				
3603760	01S/03W-29Q02S	REDLANDS, CITY OF	W	WELL 39		302	1,086	935	999	1,082	881	881				
3603761	01S/03W-18R	REDLANDS, CITY OF	W	CALIF. ST. IRRIGATION		588	654	501	509	627	576	576				
3603762	01S/03W-13M	REDLANDS, CITY OF	W	AIRPORT 2		754	888	346	102	248	468	468				
3603766	01S/03W-10K01S	REDLANDS, CITY OF	W	NORTH ORANGE #1		2,232	1,823	1,208	614	2,043	1,584	1,584				
3603767	01S/03W-10K02S	REDLANDS, CITY OF	W	NORTH ORANGE #2		2,741	1,760	1,987	1,024	2,087	1,920	1,920				
3603769	01N/05W-25E	WEST VALLEY WATER DIST	W	#05A SYCAMORE VALLE		1,319	1,024	405	312	134	639	639				
3603774	01S/03W-03R04S	EAST VALLEY WATER DISTRICT	W	146A - 7938 CHURCH		1,010	880	228	168	871	631	631				
3603776	01S/04W-24B03S	LOMA LINDA, CITY OF	W	MTN. VIEW #5		592	44	138	0	0	155	155				
3603777	01N/05W-26A06S	WEST VALLEY WATER DIST	W	#04A		1,338	1,020	766	1,694	1,571	1,278	1,278				
3603778	01N/05W-36R06S	WEST VALLEY WATER DIST	W	#08A		1,659	2,548	692	44	5	990	990				
3603786	01N/04W-33R	SAN BERNARDINO, CITY OF	W	EPA 108		2,362	2,399	1,882	2,070	2,256	2,194	2,194				
3603787	01N/04W-33P	SAN BERNARDINO, CITY OF	W	EPA 109		1,997	1,751	1,431	1,402	1,430	1,602	1,602				
3603788	01N/04W-33N	SAN BERNARDINO, CITY OF	W	EPA 110		2,493	2,253	1,683	1,464	1,649	1,908	1,908				
3603789	01N/04W-32R	SAN BERNARDINO, CITY OF	W	EPA 111		2,284	2,129	2,497	2,469	2,206	2,317	2,317				
3603790	01N/04W32Q	SAN BERNARDINO, CITY OF	W	EPA 112		2,472	2,177	1,698	1,329	1,665	1,868	1,868				
3603791	02N/05W-19R05S	SAN BERNARDINO, CITY OF	W	KENWOOD 2		1,850	1,419	1,369	1,608	1,362	1,522	1,522				
3603792	01N/05W-03A03S	SAN BERNARDINO, CITY OF	W	CAJON 4		1,558	1,348	1,283	1,397	2,285	1,574	1,574				
3603795	01S/03W-18N06S	MOUNTAIN VIEW POWER CO.	W	MVL MID-AQUIFER #1		1,031	972	1,172	1,225	1,864	1,253	1,253				
3603796	01S/03W-18M01S	MOUNTAIN VIEW POWER CO.	W	MVL MID-AQUIFER #2		1,073	935	838	449	356	730	730				
3603900	01S/02W-04N	SAN BERNARDINO COUNTY FLOOD CONTROL	W	DOMESTIC WELL NO. 3		4	4	4	10	4	5	5				
3603902	01N/05W-23P07S	WEST VALLEY WATER DIST	W	#01A		839	765	382	246	43	455	455				
3603904	01S/03W-05D09S	EAST VALLEY WATER DISTRICT	W	132-5		2,032	1,544	835	1,479	924	1,363	1,363				
3603914	01S/04W-08J03S	COLTON, CITY OF	W	#27		1,698	1,733	1,159	181	1,021	1,158	1,158				
3603915	01S/04W-08F17S	COLTON, CITY OF	W	#28		621	396	459	0	298	355	355				
3603917	01N/04W-33R03S	SAN BERNARDINO, CITY OF	W	EPA 108S		924	925	891	929	765	887	887				
3603919	01S/03W-20A03S	CALVARY CHAPEL SCHOOL	W	SCHOOL IRRIGATION		10	10	10	85	85	40	40				
3603926	01S/03W-06L06S	EAST VALLEY WATER DISTRICT	W	WELL 151-HIGHLAND		0	1,748	1,809	2,417	2,404	1,676	1,676				
3603927	01S/04W-24L07S	LOMA LINDA, CITY OF	W	RICHARDSON #6		0	0	1,372	1,989	1,188	910	910				
3603930	01N/04W-17A01S	CALIFORNIA STATE UNIVERSITY, SAN BERNARDI	W	IRRIGATION WELL 1		208	185	162	165	185	181	181				
3603932	01N/04W-35L06S	SAN BERNARDINO COUNTY - FACILITY MANAGE	W	COUNTY HOSP-GIBERT		118	0	4	0	0	24	24				
3603933	01N/05W-04B	SAN BERNARDINO COUNTY - REGIONAL PARKS	W	GLEN HELEN 1A (2)		34	40	39	4	39	31	31				
3603934	02N/05W-33F	SAN BERNARDINO COUNTY - FACILITY MANAGE	W	GLEN HELEN 3		265	808	206	34	193	301	301				
3603935	02N/05W-33G01S	SAN BERNARDINO COUNTY - FACILITY MANAGE	W	GLEN HELEN 4		16	18	274	362	111	156	156				
3603936	02N/05W-33D01S	SAN BERNARDINO COUNTY - FACILITY MANAGE	W	GLEN HELEN #5		2	0	290	314	115	144	144				

**WESTERN - SAN BERNARDINO WATERMASTER
VERIFIED PRODUCTION DATA - NON PLAINTIFFS
CROSS INDEX BY RECORDATION NUMBER
SAN BERNARDINO BASIN**

RECRD TN NUMBER	STATE WELL NUMBER	OWNER	WELL TYPE	LOCAL DESIGNATION	YEAR CLOSED	-----CALENDAR YEAR EXTRACTIONS-----										
						2008	2009	2010	2011	2012	AVG					
3603937	02N/05W-33G02S	SAN BERNARDINO COUNTY - FACILITY MANAGE	W	GLEN HELEN #6		626	354	266	148	447	368					
3603938	01N/04W-14C	CAMPUS CRUSADE FOR CHRIST	D	WEST TWIN CRK		40	40	40	40	40	40					
3603943	01S/03W-15N	REDLANDS, CITY OF	W	WEATHERWAX #2		32	33	32	32	55	37					
3603944	01S/04W-22C06S	SAN BERNARDINO VALLEY M.W.D.	W	DE-WATERING #1		0	290	0	0	0	0					
3603945	01S/04W-22F01S	SAN BERNARDINO VALLEY M.W.D.	W	DE-WATERING #2		0	0	0	0	0	0					
3603949	01S/04W-26F	MONTECITO MEMORIAL PARK	W	MONTECITO #2		0	0	223	138	177	108					
3603955	01S/04W-24B05S	LOMA LINDA, CITY OF	W	RICHARSON #5					1,252	1,305	511					
3603956	01S/04W-24B04S	LOMA LINDA, CITY OF	W	MTN. VIEW #6					740	1,537	455					
3603960	01S/04W-15P06S	SAN BERNARDINO, CITY OF	W	ORANGE SHOW RD/PRO		255	20	1	0	0	55					
3603964	01S/04W-05F02S	SAN BERNARDINO VALLEY M.W.D.	W	9TH STREET NORTH						1,565	313					
3603965	01S/04W-05F01S	SAN BERNARDINO VALLEY M.W.D.	W	9TH STREET SOUTH						1,350	270					
3603967	01S/02W-20G	JACINTO FARMING, LARRY	W	SAPPHIRE							1					
3604011	01S/03W-18N04S	MOUNTAIN VIEW POWER CO.	W	AUX 2A	2005	0	0	0	0	0	0					
3604012	01N/04W-35R	BASELINE GARDENS MUTUAL WATER COMPANY	W	WELL #4		0	0	0	0	0	0					
3690723	01S/04W-10F01S	SOUTHERN CALIFORNIA EDISON	W	HANFORD1	1981	0	0	0	0	0	0					
3690927	01N/03W-31B01S	SAN BERNARDINO, CITY OF	W	PATTON 6	1984	0	0	0	0	0	0					
3692174	01S/04W-02A	EAST VALLEY WATER DISTRICT	W	PL 105	1984	0	0	0	0	0	0					
TOTALS FOR 794 WELLS						189,335	169,860	160,639	165,053	175,002	171,978					

CHANGE IN OWNERSHIP FROM BASE PERIOD

CHANGE IN OWNERSHIP FROM BASE PERIOD

FORMER OWNER	PRESENT OWNER	RECORDATION NUMBER	STATE WELL NUMBER	YEAR CHANGE SHOWN IN VOLUME 1
AEROSPACE	SAN BERNARDINO, COUNTY OF	NF	1S4W14A	1973
ANDERSON MUTUAL WELL COMPANY, INC	EAST SAN BDNO. COUNTY WATER DIST.	3600275	1N3W32	1970
BARTON DEVELOPMENT	EAST VALLEY WATER DISTRICT	3600275	1N3W32	1982
BASELINE & LAPRAIX WELL	ALLISON FARMS	3600418	1S3W19G	2006
BEAR VALLEY MUTUAL WATER COMPANY	EAST SAN BDNO. COUNTY WATER DIST.	3600466	1N3W04	1973
BEELE, RAYMOND A.	EAST VALLEY WATER DISTRICT	3600466	1N3W04	1982
BEVERLY ASSOCIATES REC 3602065	EAST SAN BDNO. COUNTY WATER DIST.	3600026	1S3W4J	1971
BIG BEAR MUNICIPAL WATER DISTRICT	EAST VALLEY WATER DISTRICT	3600026	1S3W4J	1982
BIG BEAR TIMBER COMPANY	REDLANDS, CITY OF	3601586	1S3W15F02S	1987
BRYN MAWR MUTUAL WATER COMPANY	TROJAN GROVES	3600451	1S3W15	1989
CALAGONIA GROVES	REDLANDS, CITY OF REC 3602732	3602732	1S3W32J2	1978
CALIFORNIA, STATE OF PATTON HOSPITAL	SAN BERNARDINO VALLEY MWD	3603116	1S3W13R01S	1996
CAMPUS CRUSADE FOR CHRIST	GOLDEN STATE BLDG. PRODUCTS	3602127	1S3W15A1	1973
CAMERON RANCHO MUTUAL WATER COMPANY	GOLDEN BEAR FOREST PROD.	3602127	1S3W15A1	1980
CANYON KNOLLS RANCH	REDLANDS, CITY OF	3600053	1S3W31A02S	2002
CANYON KNOLLS RANCH	SUNWEST	3600054	1S3W31A03S	2003
CANYON KNOLLS RANCH	C. L. PHARRIS	3600055	1S3W31A06S	2003
CANYON KNOLLS RANCH	CEMEX CONSTRUCTION MATERIALS, INC.	3602109	1S3W31B01S	2002
CANYON KNOLLS RANCH	CRIM, W. ROSCOE	3603653	1S3W10J2	1997
CANYON KNOLLS RANCH	EAST SAN BDNO. COUNTY WATER DIST.	3603653	1S4W10J2	1998
CANYON KNOLLS RANCH	EAST VALLEY WATER DISTRICT	3603653	1S2W10J2	2000
CANYON KNOLLS RANCH	EAST SAN BDNO. COUNTY WATER DIST.	3601171	1S3W20F	1974
CANYON KNOLLS RANCH	EAST VALLEY WATER DISTRICT	3600926	1S4W01F2	1973
CANYON KNOLLS RANCH	EAST SAN BDNO. COUNTY WATER DIST.	3600926	1N4W01F2	1982
CANYON KNOLLS RANCH	EAST VALLEY WATER DISTRICT	3600928	1N3W31L2	1973
CANYON KNOLLS RANCH	EAST SAN BDNO. COUNTY WATER DIST.	3600928	1N3W31L2	1982
CANYON KNOLLS RANCH	EAST VALLEY WATER DISTRICT	3600930	1N3W31L3	1973
CANYON KNOLLS RANCH	EAST SAN BDNO. COUNTY WATER DIST.	3600930	1N3W31L3	1982
CANYON KNOLLS RANCH	SAN BERNARDINO, CITY OF	3600927	1N3W31B1	1973
CANYON KNOLLS RANCH	EAST SAN BDNO. COUNTY WATER DIST.	3600927	1N3W31B1	1980
CANYON KNOLLS RANCH	EAST VALLEY WATER DISTRICT	3600927	1N3W31B1	1982
CANYON KNOLLS RANCH	ARROWHEAD WATER AND POWER	3601979	1N4W14A	2004
CANYON KNOLLS RANCH	EAST SAN BDNO. COUNTY WATER DIST.	3600643	1N4W25K1	1973
CANYON KNOLLS RANCH	EAST VALLEY WATER DISTRICT	3600643	1N4W25K1	1982
CANYON KNOLLS RANCH	LOMA LINDA HEIGHTS RANCHO	3601632	2S3W05A2	1979
CANYON KNOLLS RANCH	CANYON KNOLLS RANCH	3601632	2S3W05A2	1982

CHANGE IN OWNERSHIP FROM BASE PERIOD

FORMER OWNER	PRESENT OWNER	RECORDATION NUMBER	STATE WELL NUMBER	YEAR CHANGE SHOWN IN VOLUME 1
CARDEY, MAX	DEER PARK LLC	3601632	2S3W05A02S	2004
CARL'S RANCH C/O REDLANDS FARMING CO.	AIELLO RANCH C/O CRIM GROVE CARE 1970-71	3601172	1S3W20C	1970
	CRIM WELL C/O REDLANDS FARMING CO.1972-75	3601172	1S3W20C	1972
	HUNTER/CRIM/ZARUBICA WELL 1975-	3601172	1S3W20C	1975
	K INV./TRUTANIC/Y UN WELL	3601172	1S3W20C	1981
CHURCH STREET MUTUAL WELL CO	REDLANDS, CITY OF	3602106	1S3W22A1	1970
CITRUS PROPERTY MANAGEMENT CO.	BELL, H. EUGENE	3600449	1S3W20	1974
CLIFFSIDE RANCH	TEAGLE, M., ESTATE	3602571	1S3W03F	1974
	EAST SAN BER. CO. WATER DIST.	3602571	1S3W3F	1978
	EAST VALLEY WATER DISTRICT	3602571	1S3W3F	1982
COLTON AVENUE WATER COMPANY	REDLANDS, CITY OF	3600085	1S3W28J1	1973
		3602346	1S3W28J2	1973
COOK ORCHARDS CO.	EADINGTON FRUIT CO. COOK RANCH	3600527	1S3W16	1975
CORWIN WELL COMPANY	EAST SAN BDNO. COUNTY WATER DIST.	3601184	1N3W33F1	1973
COUNTY HOSPITAL	EAST VALLEY WATER DISTRICT	3601184	1N3W33F1	1982
COURT STREET WATER COMPANY	SAN BERNARDINO, COUNTY OF	NF	1N4W35F	1971
	LOMA LINDA, CITY OF	3601384	1S4W25	1971
		3601388	1S4W25	1971
CRAM, FRANCES L.	COGBILL, CLINTON L.	3601628	1S2W09Q	1979
CRAM RANCH ASSOCIATES	VILLAGE LAKES	3600241	1S3W03Q	2006
CRIM, W. ROSCOE	RAMIREZ, J.J.	3601171	1S3W20F	1996
DANIELS, DON	DANIELS AND BEST RANCH	3602549	1S3W19J	1973
	PHAROAH'S LOST KINGDOM			1996
DANIELS, HAROLD	DANIELS AND BEST RANCH	3602550	1S3W17R	1973
DEL ROSA MUTUAL WATER CO.	EAST SAN BDNO. COUNTY WATER DIST.	3602370	1N4W25F	1976
	EAST VALLEY WATER DISTRICT	3602370	1N4W25F	1982
DEL ROSA MUTUAL WATER CO.	HODGDON, WARNER	3601810	1N4W23E	1976
	CAMPUS CRUSADE FOR CHRIST	3601810	1N4W23E	1987
	HODGDON, WARNER	3601811	1N4W14	1976
	CAMPUS CRUSADE FOR CHRIST	3601811	1N4214	1987
DOUGLAS GAS STATION	TEXACO GAS STATION	NF	1S4W24J	1973
DUDA, WALTER AND BETTY	MCCALLA, ROBERT	3601839	1S3210D01S	1992
E R DUNLOP	HOOVER WELL	3601649	1S3W28M	1973
	RAMIREZ, CARLOS	3601649	1S3W28M	1980
	HOOVER WELL	3601649-	1S3W28M	1973

CHANGE IN OWNERSHIP FROM BASE PERIOD

FORMER OWNER	PRESENT OWNER	RECORDATION NUMBER	STATE WELL NUMBER	YEAR CHANGE SHOWN IN VOLUME 1
	RAMIREZ, CARLOS	3601649-	1S3W28M	1980
EADINGTON FRUIT CO. COOK RANCH	RAMIREZ, J.J.	3600527	1S3216	1996
EAST COLTON AVENUE WATER COMPANY	HINCKLEY, HORACE P.	3600240	1S2W30D	1982
		3601645	1S2W30B	1982
EAST HIGHLANDS DOMESTIC WATER CO	SARATOGA DEVELOPMENT CO.	3600607	1S3W02	1973
	EAST HIGHLANDS RANCH INC.	3600607	1S3W02	1980
	SARATOGA DEVELOPMENT CO.	3600607-	1S3W02	1973
	EAST HIGHLANDS RANCH INC.	3600607-	1S3W02	1980
EAST HIGHLANDS ORANGE COMPANY	SARATOGA DEVELOPMENT CO.	NF	1S2W06	1977
		3600598	1S3W02	1973
	EAST HIGHLANDS RANCH INC.	3600598	1S3W02	1980
	SARATOGA DEVELOPMENT CO.	3600604	1S2W07B	1973
	EAST HIGHLANDS RANCH INC.	3600604	1S2W07B	1980
	SARATOGA DEVELOPMENT CO.	3600605	1N3W36	1973
	EAST HIGHLANDS RANCH INC.	3600605	1N3W36	1980
	SARATOGA DEVELOPMENT CO.	3600606	1N3W35	1973
	EAST HIGHLANDS RANCH INC.	3600606	1N3W35	1980
	SARATOGA DEVELOPMENT CO.	3601639	1S3W03R1	1973
	EAST HIGHLANDS RANCH INC.	3601639	1S3W03R1	1980
	EAST VALLEY WATER DISTRICT	3601639	1S3W03R1	1995
	SARATOGA DEVELOPMENT CO.	3602474	1N3W25Q	1973
	EAST HIGHLANDS RANCH INC.	3602474	1N3W25Q	1980
SUNRISE RANCH PART. C/O LIFE DEVEL. CO.		3600599	1S2W13	1973
		3600600	1S2W13	1973
		3600601	1S2W14	1973
		3600602	1S2W15P	1973
		3600603	1S2W15G	1973
		3601640	1S2W14	1973
		3601969	1S2W14L	1973
EAST HIGHLANDS ORANGE COMPANY	SUNRISE RANCH PART. C/O LIFE DEVEL. CO.	3600005	1S3W35H08S	1996
EAST LUGONIA MUTUAL WATER CO.	REDLANDS, CITY OF	3600006	1S2W19G01S	1996
		3600038	1S2W17	1996
EAST SAN BDNO. COUNTY WATER DISTRICT	EAST VALLEY WATER DISTRICT	NF	1N3W30C	1982
		NF	1S3W04P	1982
		NF	1N3W30C	1982

CHANGE IN OWNERSHIP FROM BASE PERIOD

FORMER OWNER	PRESENT OWNER	RECORDATION NUMBER	STATE WELL NUMBER	YEAR CHANGE SHOWN IN VOLUME 1
		NF	1N3W31A	1982
		NF	1S3W05Q	1982
		NF	1N4W36H	1982
EAST SAN BDNO. COUNTY WATER DISTRICT	EAST VALLEY WATER DISTRICT	NF	1S3W06	1982
		NF	1N3W31D	1982
		NF	1S3W06E	1982
		NF	1S3W06B	1982
		NF	1S3W06C	1982
		NF	1S4W02L	1982
		NF	1S3W06P	1982
		NF	1S3W05Q	1982
		NF	1S3W06M	1982
		NF	1S3W06Q	1982
		NF	1S3W03N	1982
		NF	1N4W25D	1982
		NF	1S3W03N	1982
		NF	1S3W05J	1982
		NF	1S4W01D	1982
		NF	1S3W06N	1982
EAST SAN BDNO. COUNTY WATER DISTRICT	EAST VALLEY WATER DISTRICT	3600026	1S3W04J01S	2006
		3600058	1S3W03F	1982
		3600183	1S4W02	1982
		3600444	1N3W30H01S	1982
		3600855	1N3W28P01S	1982
		3600864	1N3W19	1982
		3600970	1N3W19	1982
		3600971	1N3W19F	1982
		3601584	1N3W33H01S	1982
		3601653	1N4W36K04S	1982
		3601654	1N4W36	1982
		3601655	1N4W36K05S	1982
		3601656	1N4W36Q01S	1982
		3601657	1S4W01B04S	1982
		3601658	1N4W36R01S	1982
		3601659	1S3W06H01S	1982

CHANGE IN OWNERSHIP FROM BASE PERIOD

FORMER OWNER	PRESENT OWNER	RECORDATION NUMBER	STATE WELL NUMBER	YEAR CHANGE SHOWN IN VOLUME 1
		3601660	1D3W06H04S	1982
		3601661	1S4W01J08S	1982
		3601662	1S4W02Q05S	1982
		3601663	1S4W02Q04S	1982
EAST SAN BDNO. COUNTY WATER DISTRICT	EAST VALLEY WATER DISTRICT	3601664	1S4W02N01S	1982
		3601665	1S4W01K04S	1982
		3601666	1N4W36F08S	1982
		3601667	1S3W06A05S	1982
		3601668	1S4W01E02S	1982
		3601669	1N4W36H06S	1982
		3601670	1N4W26A01S	1982
		3601671	1N4W26A02S	1982
		3601672	1N4W25B	1982
		3601673	1N4W25C02S	1982
		3601674	1N4W25G01S	1982
		3601675	1N4W25A01S	1982
		3601676	1S4W12B05S	1982
		3601677	1S3W05A02S	1982
		3601678	1S3W05B04S	1982
		3601679	1S3W05N05S	1982
		3601781	1S3W06K01S	1982
		3601884	1N3W31C02S	1982
		3601978	1S3W04N	1982
	HODGDON, WARNER	3601979	1N4W14A	1976
	CAMPUS CRUSADE FOR CHRIST	3601979	1N4W14A	1987
	EAST VALLEY WATER DISTRICT	3602034	1S4W01Q	1982
		3602113	1N3W30N	1982
		3602274	1N3W30J	1982
		3602337	1N4W26A	1982
		3602338	1S3W04N	1982
		3602563	1S4W02Q	1982
		3602564	1S4W12B	1982
		3602799	1S2W07H01	1982
EAST VALLEY WATER DISTRICT	GREENSPOT VILLAGE & MARKET	3600026	1S3W04J01S	2006
	OSCAR MORA/MICHAEL O'CONNOR	3600269	1N3W31E01S	2006

CHANGE IN OWNERSHIP FROM BASE PERIOD

FORMER OWNER	PRESENT OWNER	RECORDATION NUMBER	STATE WELL NUMBER	YEAR CHANGE SHOWN IN VOLUME 1
ELLENA, JOHN B.	SAN BERNARDINO, CITY OF	3602712	1N4W08N	1977
FONTANA UNION WATER COMPANY 3600566	FONTANA UNION WATER COMPANY	3602727	1N5W15Q02S	1977
FRINK RANCH RECORDATION NO 3601131	RAMIREZ BROTHERS REC. NO.	3601728	1S3W30	1970
GIFFORD PARK MUTUAL WATER CO.	SAN BERNARDINO, CITY OF	3602128	1S4W14A	1987
HACIENDA TRAILER PARK	EAST SAN BDNO. COUNTY WATER DIST.	3602252	1S4W14B	1987
HICKS, JOHN/LOUISE	EAST VALLEY WATER DISTRICT	NF	1S3W04Q	1970
HOBBS WELL PARTNERSHIP	REYNOLDS, BILL	NF	1S3W04Q	1982
HOLIDAY ROCK CO.	REDLANDS COUNTRY CLUB	3600981	1S2W21H01	1978
INSMART DEVELOPMENT CO	REDLANDS TRAP/SKEET	3600049	1S3W25M	1994
INSMART DEVELOPMENT CO	SAN BERNARDINO, CITY OF	3600049-	1S3W25M	1994
ICE PRODUCTS INC.	SAN BERNARDINO, CITY OF	3600628	1S3W15G	1974
INDUST. ACRES C/O CITRUS INVESTMENT	SAN BERNARDINO, CITY OF	3600034	1S4W16H	1970
INLAND FARMING CO.	SAN BERNARDINO, CITY OF	3600035	1S4W15M1	1970
INLAND VALLEY DEVELOPMENT AGENCY	HOLMES ICE & COLD STORAGE CO., INC.	3602285	1S4W15D5	1970
INTER CITY MUTUAL WATER CO.	MENTONE CITRUS GROVES	3600644	1S4W09B03S	1983
JACINTO, FRANK JR	RIEDMAN, FRED M.	3600645	1S4W09B01S	1983
JACINTO FARMING, INC	BARNO, JOHN	3600139	1S2W18R01S	1975
JOHANSSON, RUNE	SAN BERNARDINO, CITY OF	3602280	1S2W18Q	1975
LAND CAPITOL CORP & DONALD SOJKA	SAN BERNARDINO, CITY OF	3602079	1S3W03F	1974
LANGFORD RANCHES	SAN BERNARDINO, CITY OF	3602079	1S3W03F	1977
LANKERSHIM MUT. WTR. CO.	SAN BERNARDINO, CITY OF	3603649	1S3W07A	2006
	SAN BERNARDINO, CITY OF	3601316	1S4W23N	1977
	F. A. R. WELL	3602521	1S4W23N4	1977
	MCCLINTOCK, W.L. 1970-1972	3602020	1S2W20K	1973
	YAHIKU, PAUL 1973-	3601280	1S3W29D	1970
	BENNETT 1976-1978	3601280	1S3W29D	1973
	SO. SAN BERNARDINO CO. WATER DIST	3602060	1S4W24P	1976
	SAN BERNARDINO, CITY OF	3602060	1S4W24P	1979
	SOJKA, DONALD R.	3602060	1S4W24P	1990
	CANYON RANCH	3601173	1S3W32K	1975
	REDLANDS FARMING	3600523	1S3W32G3	1973
	EAST VALLEY WATE DISTRICT	3600525	1S3W17H01S	2006
	EAST VALLEY WATE DISTRICT	0000076	1S3W06L	1990
	EAST VALLEY WATE DISTRICT	0000077	1S3W06F	1990

CHANGE IN OWNERSHIP FROM BASE PERIOD

FORMER OWNER	PRESENT OWNER	RECORDATION NUMBER	STATE WELL NUMBER	YEAR CHANGE SHOWN IN VOLUME 1
LARSEN, ERNEST R.	LARANNI GUNTER WELL	3600160	1S3W32G1	1974
LA TOURETTE	DANGERMOND, JACK	0000078	1S2W28M	2006
LEONARD, WILLIAM E.	SAN BERNARDINO INVESTORS	3602499	1S4W22A01	1979
LORD	J. G. GOLFING ENTERPRISES, INC.	3602499	1S4W22A01	1981
	DANGERMOND, JACK	0000079	1S2W28M	2006
LOMA LINDA, CITY OF	SAN BERNARDINO COUNTY	3601130	1S3W32D	2004
LONG ACRES MUTUAL WATER CO	STORKSON, WILLIAM F.	3600083	1N5W6	1970
L.P.R. RANCH	L.P.R. ICE COMPANY	3602525	1S3W13C	1971
		3600018	1S2W29	1976
LUGO WATER COMPANY	REDLANDS, CITY OF	3600510	1S3W21K01S	2001
LUGONIA WATER COMPANY	REDLANDS, CITY OF	3601585	1S3W23A03S	1987
	BEAR VALLEY MUTUAL WATER COMPANY	3601585	1S3W23A03S	1990
MARIGOLD FARMS COMPANY	BARTON DEVELOPMENT	3600418	1S4W19	1994
		3601748	1S3W18H01	1994
		3601748-	1S3W19A01	1994
MASCART WATER COMPANY	MAJESTIC MANAGEMENT	3601102	1S3W21E	2001
MEKS & DALEY (1N3W31)	BASELINE LAUNDRY	NF	1N3W31	1973
MONTONE ACRES MUTUAL WELL CO.	REDLANDS, CITY OF	3600749	1S3W13	1983
		3600748	1S3W24A1	1999
		3601308	1S2W19K1	1978
		3602653	1S2W19J	1978
		3602654	1S2W19J	1978
MENTONE DOMESTIC WATER CO.	REDLANDS, CITY OF	3602174	1S4W02	1974
		3602174	1S4W02	1975
MEYER, ERNEST	EAST SAN BDNO. COUNTY WATER DIST.	3602174	1S4W02	1980
	MEYER, ERNEST	3602174	1S4W02	1982
	EAST SAN BDNO. COUNTY WATER DIST.	3602174	1S4W02	1982
	EAST VALLEY WATER DISTRICT	3600756	1S3W19H	1987
MISSION MUTUAL WATER COMPANY	REDLANDS, CITY OF	3600757	1S3W19L	1987
	MARIGOLD FARMS COMPANY	3600119	1S4W26F01	1995
MONTECITO MUTUAL WATER COMPANY	MT. VIEW CEMETERY OF SAN BERNARDINO	3600220	1S3W01H	1994
MT. HARRISON MUTUAL WATER CO.	EAST VALLEY WATER DISTRICT	3600320	1N5W22M	1997
MOUNT VERNON WATER COMPANY	SAN BERNARDINO, CITY OF	3602074	1N3W34B02	1991
MULLINS, JAMES C., JR., EXECUTOR	TILDEN, M. WILLIAM	3602075	1N3W34B01	1991
MUTUAL WELL CO. (OF HIGHLAND)	NORTH FORK WATER	3600765	1N3W33C01	1981
NAMIHAS, M.D. IVAN/SHIRLEY	SOUZA, JOHN	3601084	1S2W20K	1980

CHANGE IN OWNERSHIP FROM BASE PERIOD

FORMER OWNER	PRESENT OWNER	RECORDATION NUMBER	STATE WELL NUMBER	YEAR CHANGE SHOWN IN VOLUME 1
NICKERSON, E. D.	WARMINGTON, ROBT. P.	3600270	1S3W20P	1982
NORTH FORK WATER COMPANY	DUCKWORTH, JOHN	3600765	1N3W33C01S	2006
	EAST VALLEY WATER DISTRICT	3600680	1S3W02	1982
	EAST VALLEY WATER DISTRICT	3601184	1N3W33F01S	2008
	EAST SAN BDNO. COUNTY WATER DIST.	3601643	1S3W03Q	1982
	EAST VALLEY WATER DISTRICT	3601643	1S3W03Q	1982
	DUCKWORTH, JOHN	3600765	1N3W33C01S	2006
NORTON AIR FORCE BASE	INLAND VALLEY DEVELOPMENT AGENCY	0000086	1S4W12B	1997
	0000086 BECOMES FILER	3600645	1S4W07D	1998
		0000087	1S4W12C	1997
NORTON AIR FORCE BASE	0000087 BECOMES FILER	3603647		1998
		0000088	1S4W12D	1997
		0000089	1S3W07A	1997
	0000089 BECOMES FILER	3603649	1S3W07A	1998
		0000090	1S3218C	1997
	0000090 BECOMES FILER	3603650		1998
NORTON VILLAGE, LTD.	EAST SAN BDNO. COUNTY WATER DIST.	3600925	1S4W01Q1	1973
	EAST VALLEY WATER DISTRICT	3600925	1S4W01Q1	1982
	DANGERMOND, JACK	3600313	1S2W29N01S	2006
OLD TOWN WELL COMPANY	MONTE LLC	3600493	1S3W29K	2006
		3600494	1S3W29K	2006
ORANGE ST. RANCH	CRAM RANCH ASSOCIATES	3600241	1S3W03Q	1980
PAINE, ROBERT T. TRUSTEE	REDLANDS UNIFIED SCHOOL DISTRICT	3601641	1S2W30C01S	1996
PEYTON, A.L. OR IRENE A.	SOMERS, R.	3601093	1N4W24	1977
PEYTON, MRS. A.L.	LA BONTE, JIM	3600865	1N4W24	1978
RAMIREZ, CARLOS (HOOVER WELL)	RAMIREZ, J.J.	3601649--	1S3W28M	2010
RAMIREZ, J.J.	SAN BERNADINO COUNTY	3601171	1S3W20F	2004
RANCHERIA WATER CO. TOBIN	RIALTO, CITY OF	3601929	1S4W06C04S	1987
RANCHO LADERA	ESRI	3602188	1S2W29L	2002
REDLANDS ASSOCIATES	BLUE GOOSE GROWERS INC.	3602529	1S2W09P2	1971
		3602530	1S2W09L2	1971
		3602531	1S2W09L3	1971
	BLUE BANNER CO.	3602531	1S2W09L3	1980
REDLANDS HEIGHTS WATER COMPANY	REDLANDS, CITY OF	3602531	1S2W09L3	1980
REES-REES RANCHES, INC.	SELBY, DR. & MRS. ARTHUR	3600918	2S3W01E	1983
		3600017	1S2W29	1976

CHANGE IN OWNERSHIP FROM BASE PERIOD

FORMER OWNER	PRESENT OWNER	RECORDATION NUMBER	STATE WELL NUMBER	YEAR CHANGE SHOWN IN VOLUME 1
RIALTO MUTUAL LAND AND WATER COMPANY	REDLANDS, CITY OF	3600018	1S2W29	1976
RIVERSIDE, CITY OF 3601478	RIALTO, CITY OF	3600019	1S3W23	1978
ROBERTS, DR. G.	J. G. GOLFING ENTERPRISES, INC. 3602846	3601085	1N4W31N	1973
ROZEMA CHICKEN RANCH	PATTERSON, ROY H.	3602846	1S4W22A	1985
	QUALITY FARMS	NF	1N3W34Q	1977
		NF	1S3W04R	1975
SAN BERNARDINO, COUNTY OF	SAN BERNARDINO COUNTY PARKS	3603933	1N5W04B	2009
SAN BERNARDINO COUNTY SERVICE AREA 2	LOMA LINDA, CITY OF	3601989	1S4W24R1	1970
		3602010	1S4W25H2	1970
		3602011	1S4W25B2	1970
		3602015	1S4W25B	1970
SAN BERNARDINO WATER UTILITIES	SAN BERNARDINO, CITY OF	3602016	1S4W25G	1970
		3602057	1S4W25C	1970
		3602058	1S4W25F	1970
		3601843	1N5W03H01S	1987
		3601844	1N5W03	1987
		3601845	1N4W30L	1987
SAN BERNARDINO, CITY OF	California State University San Bernardino	3602712	1N4W08N	2001
SARATOGO DEVELOPMENT	EAST HIGHLAND RANCH	3600607	1N3W02L	2004
SECHREST, RALPH F.	RAMIREZ, J.J.	3600484	1S3W16	1978
SELEY WELL CO	EAST SAN BDNO. COUNTY WATER DIST.	3600545	1N3W30	1970
	EAST VALLEY WATER DISTRICT	3600545	1N3W30	1982
	PAXTON, R. H.	3600468	1S3W30	1971
		3600378	1N3W27N02S	1987
		3601069	1N3W33M02S	1987
		3602122	1S4W23R03S	1990
		3602123	1S4W14J	1990
		3602124	1S4W14J	1990
		3602125	1S4W24F04S	1990
		3602126	1S4W24F	1990
		3601014	1S3W18N	1998
		3601014	1S3W18N	1999
		3601015	1S3W18N	1998
		3601015	1S3W18N	1999
SOUTHERN CALIFORNIA EDISON	THERMO ECOTEK CORPORATION	3601014	1S3W18N	1998
	MOUNTAINVIEW POWER COMPANY	3601014	1S3W18N	1999
	THERMO ECOTEK CORPORATION	3601015	1S3W18N	1998
	MOUNTAINVIEW POWER COMPANY	3601015	1S3W18N	1999

CHANGE IN OWNERSHIP FROM BASE PERIOD

FORMER OWNER	PRESENT OWNER	RECORDATION NUMBER	STATE WELL NUMBER	YEAR CHANGE SHOWN IN VOLUME 1
SOUTHERN CALIFORNIA WATER COMPANY	EAST VALLEY WATER DISTRICT	3600374	1N3W33M01S	1987
		3600375	1S3W05	1987
		3600376	1S3W05	1987
		3600377	1N3W27N08S	1987
	SAN BERNARDINO, CITY OF	3601588	1N4W31H	1987
		3601878	1N4W29E01S	1987
		3601879	1N4W29	1987
		3601880	1N4W29F01S	1987
	EAST VALLEY WATER DISTRICT	3601987	1S3W04G	1987
		3602260	1S3W05D06	1987
		3602417	1S3W05D	1987
		3602560	1S3W04G	1987
	LEWIS DEVELOPMENT CO.	3601352	1S3W19N	1980
	CHRISTENSEN, JACK. O.	3601352	1S3W19N	1981
	AMERICAN GENERAL LIFE INS. CO.	3601352	1S3W19N	1987
	GENERAL AMERICAN LIFE INS. CO.	3601352	1S3W19N	1988
	RAMIREZ, J. J.	3601046	1S3W21A	2000
	BEELE, RAYMOND A.	3600451	1S3W15	1970
	EAST SAN BDNO. COUNTY WATER DIST.	3601582	1S4W02R	1975
	EAST VALLEY WATER DISTRICT	3601582	1S4W02R	1982
	TRI CITY CONCRETE	3600935	1N4W31N	1973
	TRI CITY CONCRETE	3601420	1S3W09E	1970
	LIVINGSTON-GRAHAM	3601420	1S3W09E	1980
	C. L. PHARRIS SAND & GRAVEL	3601420	1S3W09E	1992
	SUNWEST	3601420	1S3W09E	1997
	C. L. PHARRIS SAND & GRAVEL	3601420	1S3W09E	1998
	CEMEX CONSTRUCTION MATERIALS, INC.	3601420	1S3W09E	2000
	YUCAIPA VALLEY COUNTY WATER DISTRICT	3602657	1S1W20D	1975
	YUCAIPA VALLEY WATER DISTRICT	3602657	1S1W20D	1987
	YUCAIPA VALLEY COUNTY WATER DISTRICT	3602658	1S1W20D	1975
	YUCAIPA VALLEY WATER DISTRICT	3602658	1S1W20D	1987
	YUCAIPA VALLEY COUNTY WATER DISTRICT	3602659	1S1W19G	1975
	YUCAIPA VALLEY WATER DISTRICT	3602659	1S1W19G	1987
	KARHALOIS	NF	1S2W17	1975

CHANGE IN OWNERSHIP FROM BASE PERIOD

FORMER OWNER	PRESENT OWNER	RECORDATION NUMBER	STATE WELL NUMBER	YEAR CHANGE SHOWN IN VOLUME 1
VALDEPENA ACRES	CARTER, DR. JAMES E.	3602241	1S3W20F03	1997
VALLE VISTA RANCH CO.	LOMA LINDA, CITY OF	3601130	1S3W32D	1973
VAN CAMP, GILBERT C.	CALLISON, ROY A. 1977-1978	3600218	1N4W24	1977
VAN LEUVEN NURSING HOME	LANGSTON-NEWBY DEVELOPMENT CO. 1979-	3600218	1N4W24	1979
VAN LEUVEN, ED	MT. VIEW CHILD CARE CENTER	NF	1S4W24J	1978
VAN LOON MUTUAL WATER COMPANY	VICTORIA SEVENTH DAY ADVENTIST	NF	1S4W24J	1978
	SAN BERNARDINO, CITY OF	3602066	1S4W02B	1990
WEST HIGHLAND WELL COMPANY	EAST SAN BDNO. COUNTY WATER DIST.	3600221	1N3W30	1970
WEST TWIN CREEK WATER COMPANY	EAST VALLEY WATER DISTRICT	3600221	1N3W30	1982
YORK	HODGDON, WARNER	NF	1N4W14C	1976
	CAMPUS CRUSADE FOR CHRIST	NF	1N4W14C	1987
	SAN MANUEL INDIAN RESERVATION	0000160	1N3W19R	1999
		0000161	1N3W19R	1999
		0000162	1N3W19R	1999

HISTORICAL FOOTNOTES - VERIFIED EXTRACTIONS
BY NON-PLAINTIFFS WHO HAVE FILED WITH THE
STATE WATER RESOURCES CONTROL BOARD

Historic Footnotes to Western San Bernardino Watermaster
Volume 1 - Verified Extraction by Non-Plaintiffs who have filed with SWRCB

Recordation Number	Description
3600005	Redlands, City of - formerly East Lugonia Mutual Water Co.
3600006	Redlands, City of - formerly East Lugonia Mutual Water Co.
3600017	Selby, Dr. & Mrs. Arthur - formerly Ree Ranches, Inc.
3600018	Selby, Dr. & Mrs. Arthur - formerly Ree Ranches, Inc.
3600019	Redlands, City of - formerly Rees Ranches, Inc.
3600023	Bear Valley Mutual Water Company - Well renovated in 1998
3600026	East Valley Water District - formerly formerly Bear Valley Mutual Water company, formerly East San Bernardino County Water District
3600027	Bear Valley Mutual Water Company - Commencing in 1974 includes gross Santa Ana River Diversions - See Table No. 6 for verified diversions
3600028	Bear Valley Mutual Water Company - Commencing in 1974 includes gross Santa Ana River Diversions - See Table No. 6 for verified diversions
3600034	San Bernardino, City of - former Homart Development Co.
3600035	San Bernardino, City of - formerly Homart Development Co.
3600038	Redlands, City of - formerly East Lugonia Mutual Water Co.
3600049	Redland Country Club - formerly Hobs Well Partnership
3600049-	Redland Country Club - formerly Hobs Well Partnership
3600054	Redlands, City of - formerly Bryn Mawr Mutual Water Company (nc in 2003)
3600055	Redlands, City of - formerly Bryn Mawr Mutual Water Company (nc in 2003)
3600058	East Valley Water District - formerly East San Bernardino County Water District
3600083	Storkson, William F. - formerly Long Acres Mutual Water Co.
3600085	Redlands, City of - formerly Colton Avenue Water Co.
3600119	Mt. View Cemetary of San Bernardino - formerly Montecito Mutual Water Company
3600139	Mentone Citrus Groves - formerly Indust. Acres c/o Citrust Investment
3600160	Laranni Gunter Well - formerly Larsen, Ernest G.
3600174	San Bernardino Valley MWD - well drilled 1990
3600183	East Valley Water District - formerly East San Bernardino County Water District
3600218	Langston-Newby Developing Company - formerly Van Camp, Gilbert C., formerly Callison, Roy A.
3600220	East Valley Water District - formerly Mt. Harrison Mutual Water Company
3600221	East Valley Water District - formerly West Highland Well Company, formerly East San Bernardino Valley County Water District
3600240	Hinckley, Horace P. - Formerly East Colton Avenue Water Company

Historic Footnotes to Western San Bernardino Watermaster
Volume 1 - Verified Extraction by Non-Plaintiffs who have filed with SWRCB

Recordation Number	Description
3600241	Cram Ranch Associates - formerly Orange Street Ranch
3600269	East Valley Water District - formerly East San Bernardino County Water District
3600270	Warmington, Robert P. - formerly Nickerson, E.D.
3600275	East Valley Water District - formerly Anderson Mutual Well Company Inc., formerly East San Bernardino Valley County Water District
3600312	West San Bernardino County Water District - includes gross Lytle Creek diversions--see table no. 4 for verified diversions from Lytle Creek
3600320	San Bernardino, City of - includes gross Lytle Creek diversions--see tbl 4 for verified diversions from Lytle Creek - formerly Mt. Vernon Water Co.
3600374	East Valley Water District - formerly Southern California Water Company
3600375	East Valley Water District - formerly Southern California Water Company
3600376	East Valley Water District - formerly Southern California Water Company
3600377	East Valley Water District - formerly Southern California Water Company
3600378	East Valley Water District - formerly Southern California Water Company
3600418	Barton Development - formerly Marigold Farms Company
3600444	East Valley Water District - formerly East San Bernardino County Water District
3600449	Bell, Eugene H. - formerly Citrus Proerty Management Company
3600451	Trojan Groves - formerly Stucker Ranch, formerly Beeler, Raymond A.
3600466	East Valley Water District - formerly Baseline & Lapraiz Well, formerly East San Bernardino Valley County Water District
3600468	Paxton, R.H. - formerly Smith, Leona Bernice - now San Bernardino County
3600484	Ramirez, J.J. - formerly Sechrest, Ralph F.
3600510	Redlands, City of - formerly Lugo Water Company
3600523	Canyon Ranch - formerly Langford Ranches
3600527	Ramirez, J.J. - formerly Cook Orchards Co., formerly Eadington Fruit co. Cook Ranch
3600545	East Valley Water District - formerly Seley Well Company, formerly East San Bernardino Valley County Water District
3600591	Fontana Union Water Company - includes gross Lytle Creek diversions--see Table no. 4 for verified diversions from Lytle Creek
3600598	East Highlands Ranch Inc. - formerly East Highlands Orange Company, formerly Saratoga Development Company
3600599	Sunrise Ranch Part c/o Life Development - formerly East Highlands Orange Co.
3600600	Sunrise Ranch Part c/o Life Development - formerly East Highlands Orange Co.
3600601	Sunrise Ranch Part c/o Life Development - formerly East Highlands Orange Co.
3600602	Sunrise Ranch Part c/o Life Development - formerly East Highlands Orange Co.

Historic Footnotes to Western San Bernardino Watermaster
Volume 1 - Verified Extraction by Non-Plaintiffs who have filed with SWRCB

Recordation Number	Description
3600603	Sunrise Ranch Part c/o Life Development - formerly East Highlands Orange Co.
3600604	East Highlands Ranch Inc. - formerly East Highlands Orange Company, formerly Saratoga Development Company
3600605	East Highlands Ranch Inc. - formerly East Highlands Orange Company, formerly Saratoga Development Company
3600606	East Highlands Ranch Inc. - formerly East Highlands Orange Company, formerly Saratoga Development Company
3600607	East Highlands Ranch Inc. - formerly East Highlands Orange Company, formerly Saratoga Development Company
3600607-	East Highlands Ranch Inc. - formerly East Highlands Orange Company, formerly Saratoga Development Company
3600628	Redlands Trap/Skeet - formerly Holiday Rock Co.
3600643	East Valley Water District - formerly Cameron Rancho Mutual Water Company, well filled and capped in 1969, formerly East San Bernardino Valley County Water District
3600644	Holmes Ice and Cold Storage Co., Inc. - formerly Ice Products, Inc.
3600645	Holmes Ice and Cold Storage Co., Inc. - formerly Ice Products, Inc.
3600680	East Valley Water District - formerly North Fork Water Company, formerly East San Bernardino Valley County Water District
3600681	North Fork Water Company - 1996 verified amount corrected during 1998 verification
3600723	San Bernardino, City of - see also Southern California Edison Company 3690723
3600739	San Bernardino, City of - includes gross Lytle Creek diversions--see tbl 4 for verified diversions from Lytle Creek
3600748	Redlands, City of - well rehabilitated 1994, formerly Mentone Acres Mutual Water Company
3600749	Redlands, City of - formerly Mentone Acres Mutual Water Company
3600756	Redlands, City of - formerly Mission Mutual Water Co.
3600757	Manigold Farms - formerly Mission Mutual Water Co., formerly Redlands, City of
3600765	North Fork Water Company - formerly Mutual Well Company (of Highland)
3600855	East Valley Water District - formerly East San Bernardino County Water District
3600864	East Valley Water District - formerly East San Bernardino County Water District
3600865	La Bonte, Jim - formerly Peyton, Mrs. A.L.
3600918	Redlands, City of - formerly Redland Heights Water Co.
3600925	East Valley Water District - formerly Norton Village LTD., formerly East San Bernardino Valley County Water District
3600926	East Valley Water District - formerly State of California Patton Hospital, formerly East San Bernardino Valley County Water District
3600927	East Valley Water District - formerly State of California Patton Hospital, formerly City of San Bernardino, ESBCWD includes 3690927 production
3600928	East Valley Water District - formerly State of California Patton Hospital, formerly East San Bernardino Valley County Water District
3600930	East Valley Water District - formerly State of California Patton Hospital, formerly East San Bernardino Valley County Water District

Historic Footnotes to Western San Bernardino Watermaster
Volume 1 - Verified Extraction by Non-Plaintiffs who have filed with SWRCB

Recordation Number	Description
3600935	Tri City Concrete - formerly Tri City Baseline
3600970	East Valley Water District - formerly East San Bernardino County Water District
3600971	East Valley Water District - formerly East San Bernardino County Water District
3600981	Reynolds, Bill - formerly Hicks, John/Louise
3601014	Mountain View Power Company - formerly Southern California Edison, formerly Thermo Ecotek Corp.
3601015	Mountain View Power Company - formerly Southern California Edison, 1997 amount corrected during 1998 verification, formerly Thermo Ecotek Corp.
3601046	Ramirez, J.J. - formerly Stowe Water Co.
3601046-	Ramirez, J.J. - formerly Stowe Water Co.
3601069	East Valley Water District - formerly Southern California Water Company
3601084	Souza, John - formerly Namihias, M.D., Ivan/Shirley
3601085	Rialto, City of - formerly Rialto Mutual Land and Water Co.
3601093	Somers, R. - formerly Peyton, A.L. or Irene A.
3601102	Majestic Management - formerly Mascart Water Co.
3601130	San Bernardino County Flood Control (NC 2004) - formally Loma Linda, City of - formerly Valle Vista Ranch Co.
3601131	Frink Ranch - now Ramirez Brothers Recordation no. 3601728
3601171	San Bernardino County (nc 2004) - formally Ramirez, J.J. - formerly Calagonia Groves; formerly Crim, W. Roscoe
3601172	K. Inv./Trutanic/Y Un Well - formerly Carl's Ranch, formerly Atello Ranch, formerly Crim Well, formerly Hunter/Crim/Zarubica
3601173	Sojka, Donald R. - formerly Land Capitol Corp & Donald Sojka
3601184	East Valley Water District - formerly Corwin Well Company, formerly East San Bernardino Valley County Water District
3601297	City of Redlands Well #17 noted as demolished and filled in 2010
3601280	Yahiku, Paul - formerly Jacinto Farming Inc.
3601302	Redlands, City of - commencing 1974 includes gross Mill Creek diversions--see Table no. 5 for verified diversions
3601308	Redlands, City of - formerly Mentone Domestic Water Company, Inc.
3601316	San Bernardino, City of - formerly Inter City Mutual Water Co.
3601352	General American Life Insurance Company - after 1988 includes water pumped by city of Redlands from this well - formerly Stanley Brown Co.- formerly Christensen, Jack O.
3601384	Loma Linda, City of - formerly Court St. Water Co.
3601388	Loma Linda, City of - formerly Court St. Water Co.
3601420	Cemex Construction Materials Inc., formerly Tri City Rock, Tri City Concrete, Livingston-Graham, Pharris Sand and Gravel, Southwest Materials

Historic Footnotes to Western San Bernardino Watermaster
Volume 1 - Verified Extraction by Non-Plaintiffs who have filed with SWRCB

Recordation Number	Description
3601498	Muscoy Mutual Water Company no. 1 - well renovated 1979
3601582	East Valley Water District - formerly Sunnyside Mutual Water Company, formerly East San Bernardino Valley County Water District
3601584	East Valley Water District - formerly East San Bernardino County Water District
3601585	Bear Valley Mutual Water Company - formerly Lugonia Water Company, formerly City of Redlands
3601586	Redlands, City of - formerly Bear Valley Mutual Water Company
3601588	San Bernardino, City of - formerly Southern California Water Co.
3601628	Cogbill, Clinton L. - formerly Frances L. Cram
3601632	Deer Park LLC (NC 2004) - formally Max Cardey/Clock Canyon
3601636	Redlands, City of - production included in amount reported by Stanley Brown Co., recordation no. 3601352 subsequent to 1968
3601639	East Valley Water District - formerly East Highlands Ranch, East Highlands Orange Company, Saratoga Development
3601640	Sunrise Ranch Part c/o Life Development - formerly east Highlands Orange Co.
3601641	Redlands Unified School District - formerly Paine, Robert T., trustee
3601643	East Valley Water District - formerly North Fork Water Company, formerly East San Bernardino Valley County Water District
3601645	Hinckley, Horace P. - Formerly East Colton Avenue Water Company
3601649	Ramirez, Carlos - formerly E.R. Dunlop, formerly Hoover Well
3601649-	Ramirez, Carlos - formerly E.R. Dunlop, formerly Hoover Well Transferred to J.J. Ramirez in 2010
3601653	East Valley Water District - formerly East San Bernardino County Water District
3601654	East Valley Water District - formerly East San Bernardino County Water District
3601655	East Valley Water District - formerly East San Bernardino County Water District
3601656	East Valley Water District - formerly East San Bernardino County Water District
3601657	East Valley Water District - formerly East San Bernardino County Water District
3601658	East Valley Water District - formerly East San Bernardino County Water District
3601659	East Valley Water District - formerly East San Bernardino County Water District
3601660	East Valley Water District - formerly East San Bernardino County Water District
3601661	East Valley Water District - formerly East San Bernardino County Water District
3601662	East Valley Water District - formerly East San Bernardino County Water District
3601663	East Valley Water District - formerly East San Bernardino County Water District

Historic Footnotes to Western San Bernardino Watermaster
Volume 1 - Verified Extraction by Non-Plaintiffs who have filed with SWRCB

Recordation Number	Description
3601664	East Valley Water District - formerly East San Bernardino County Water District
3601665	East Valley Water District - formerly East San Bernardino County Water District
3601666	East Valley Water District - formerly East San Bernardino County Water District
3601667	East Valley Water District - formerly East San Bernardino County Water District
3601668	East Valley Water District - formerly East San Bernardino County Water District
3601669	East Valley Water District - formerly East San Bernardino County Water District
3601670	East Valley Water District - formerly East San Bernardino County Water District
3601671	East Valley Water District - formerly East San Bernardino County Water District
3601672	East Valley Water District - formerly East San Bernardino County Water District
3601673	East Valley Water District - formerly East San Bernardino County Water District
3601674	East Valley Water District - formerly East San Bernardino County Water District
3601675	East Valley Water District - formerly East San Bernardino County Water District
3601676	East Valley Water District - formerly East San Bernardino County Water District
3601677	East Valley Water District - formerly East San Bernardino County Water District
3601678	East Valley Water District - well destroyed prior to base period, formerly East San Bernardino County Water District
3601679	East Valley Water District - formerly East San Bernardino County Water District
3601718	Rialto, City of - includes gross Lytle Creek diversions--see table no. 4 for verified diversions from Lytle Creek
3601728	Ramirez Brothers - formerly Frink Ranch recordation no. 3601131
3601748	Barton Development - formerly Marigold Farms Company
3601748-	Barton Development - formerly Marigold Farms Company
3601781	East Valley Water District - formerly East San Bernardino County Water District
3601810	Campus Crusade for Christ - formerly Del Rosa Mutual Water Company. Formerly Warner Hodgdon, then Arrowhead Water and Power
3601811	Campus Crusade for Christ - formerly Del Rosa Mutual Water Company. Formerly Warner Hodgdon, then Arrowhead Water and Power
3601839	McCalla, Robert - formerly Duda, Walter and Betty
3601843	San Bernardino, City of - formerly San Bernardino Water Utilities Cor
3601844	San Bernardino, City of - formerly San Bernardino Water Utilities Cor
3601845	San Bernardino, City of - formerly San Bernardino Water Utilities Cor
3601878	San Bernardino, City of - formerly Southern California Water Co.

Historic Footnotes to Western San Bernardino Watermaster
Volume 1 - Verified Extraction by Non-Plaintiffs who have filed with SWRCB

Recordation Number	
3601879	San Bernardino, City of - formerly Southern California Water Co.
3601880	San Bernardino, City of - formerly Southern California Water Co.
3601884	East Valley Water District - formerly East San Bernardino County Water District
3601929	Rialto, City of - formerly Ranceria Water Co. Tobin, well rehabilitated 1985
3601969	Sunrise Ranch Part c/o Life Development - formerly east Highlands Orange Co.
3601978	East Valley Water District - formerly East San Bernardino County Water District
3601979	Campus Crusade for Christ - formerly East Valley Water District, formerly Warner Hodgdon, then Arrowhead Water and Power
3601979	Arrowhead Water and Power(nc 2003) - formerly Campus Crsade for Christ
3601987	East Valley Water District - formerly Southern California Water Company
3601989	Loma Linda, City of - formerly San Bernardino County Service Area No. 2
3602010	Loma Linda, City of - formerly San Bernardino County Service Area No. 2
3602011	Loma Linda, City of - formerly San Bernardino County Service Area No. 2
3602015	Loma Linda, City of - formerly San Bernardino County Service Area No. 2
3602016	Loma Linda, City of - formerly San Bernardino County Service Area No. 2
3602020	F.A.R. Well - formerly Jacinto, Frank Jr.
3602034	East Valley Water District - formerly East San Bernardino County Water District
3602057	Loma Linda, City of - formerly San Bernardino County Service Area no. 2
3602058	Loma Linda, City of - formerly San Bernardino County Service Area no. 2
3602060	San Bernardino, City of - formerly Johansson, Rune, formerly Bennett, formerly South San Bernardino County Water District
3602065	Redlands, City of - formerly Beverly Associates recordation no. 3602732
3602066	San Bernardino, City of - formerly Van Loon Mutual Water Co.
3602067	San Bernardino, City of - formerly Van Loon Mutual Water Co.
3602074	Tilden, M. William - formerly mullins, James C., Jr., executor
3602075	Tilden, M. William - formerly mullins, James C., Jr., executor
3602079	Barno, John - formerly Inland Farming
3602106	Redlands, City of - formerly Church Street Mutual Well Co.
3602113	East Valley Water District - formerly East San Bernardino County Water District
3602122	San Bernardino, City of - formerly South San Bernardino County Water District

Historic Footnotes to Western San Bernardino Watermaster
Volume 1 - Verified Extraction by Non-Plaintiffs who have filed with SWRCB

Recordation Number	
3602123	San Bernardino, City of - formerly South San Bernardino County Water District
3602124	San Bernardino, City of - formerly South San Bernardino County Water District
3602125	San Bernardino, City of - formerly South San Bernardino County Water District
3602126	San Bernardino, City of - formerly South San Bernardino County Water District
3602127	Golden Bear Forest Products - formerly Big Bear Timber Company
3602128	San Bernardino, City of - formerly Gifford Park Mutual Water Co.
3602174	East Valley Water District - formerly Meyer, Ernest, formerly East San Bernardino County Water District; includes 3692174 production
3602188	ESRI - formerly Rancho Ladera
3602241	Carter, James E. M.D. - formerly Valepena Acres
3602252	San Bernardino, City of - formerly Gifford Park Mutual Water Co.
3602260	East Valley Water District - formerly Southern California Water Company
3602264	City of San Bernardino 23rd Street well noted as des
3602274	East Valley Water District - formerly East San Bernardino County Water District
3602280	Mentone Citrus Groves - formerly Indust. Acres c/o Citrust Investment
3602285	San Bernardino, City of - former Homart Development Co.
3602337	East Valley Water District - formerly East San Bernardino County Water District
3602338	East Valley Water District - formerly East San Bernardino County Water District
3602346	Redlands, City of - formerly Colton Avenue Water Co.
3602370	East Valley Water District - formerly Del Rosa Mutual Water Company, formerly East San Bernardino County Water District
3602417	East Valley Water District - formerly Southern California Water Company
3602474	East Highlands Ranch Inc. - formerly East Highlands Orange Company, formerly Saratoga Development Company
3602498	Colton, City of - well drilled in 1972
3602499	J.G. Golfing Enterprises, Inc. - formerly Leonard, William E., formerly San Bernardino Investors
3602521	San Bernardino, City of - formerly Inter City Mutual Water Co. Non-filed no. 72 prior to 1972
3602525	L.P.R. Ice Company - formerly L.P.R.Ranch non-filed no. 80 prior to 1972
3602529	Blue Goose Growers Inc. - formerly Redlands Associates non-filer # 100 prior to 1972
3602530	Blue Goose Growers Inc. - formerly Redlands Associates non-filer # 101 prior to 1972
3602531	Blue Banner Company - formerly Redlands Associates non-filer # 102 prior to 1972

Historic Footnotes to Western San Bernardino Watermaster
Volume 1 - Verified Extraction by Non-Plaintiffs who have filed with SWRCB

Recordation Number	Description
3602549	Pharohs Lost Kingdom - prior to 1973 see non-filed extractions table no. 2 Daniels, Don - formerly Daniels and Best Ranch
3602550	Daniels and Best Ranch - prior to 1973, see non-filed extractions Table #2 under Harold Daniels
3602560	East Valley Water District - formerly Southern California Water Company; well drilled 1973 extractions; verified during 1974 verification
3602563	East Valley Water District - well drilled 1972 extractions verified during 1974 verification; formerly E.S.B.C.W.D.
3602564	East Valley Water District - formerly East San Bernardino County Water District
3602571	East Valley Water District - formerly Cliffside Ranch; prior to 1974 see non-filed extractions table N. 2 Cliffside Ranch; formerly E.S.B.C.W.D.
3602574	Victoria Farms Mutual Water Company - well drilled 1972 State Well number corrected during 1983 verification
3602596	Loma Linda, City of -well drilled 1974
3602653	Redlands, City of - formerly Menton Domestic Water Company, Inc., prior to 1975 see non-filed extractions table no. 2
3602654	Redlands, City of - formerly Menton Domestic Water Company, Inc., prior to 1975 see non-filed extractions table no. 2
3602657	Yucaipa Valley Water District - formerly Y.V.C.W.D., formerly Triple Falls Mut. Wtr. Co. non-filed no. 136 prior to 1975
3602658	Yucaipa Valley Water District - formerly Y.V.C.W.D., formerly Triple Falls Mut. Wtr. Co. non-filed no. 135 prior to 1975
3602659	Yucaipa Valley Water District - formerly Y.V.C.W.D., formerly Triple Falls Mut. Wtr. Co. non-filed no. 134 prior to 1975
3602664	Storkson, William F. - original verification done during the 1975 verification
3602712	San Bernardino, City of - formerly Ellena, John B.; prior to 1977 see non-filed extractions table no. 2 Ellena, John B. California State University Well, file reopened in 2010
3602727	Fontana Union Water Company - formerly Fontana Union Water Company Recordation no. 3600566; well renovated 1977
3602759	Loma Linda, City of -well drilled 1979
3602760	Loma Linda, City of -well drilled 1980
3602766	West San Bernardino County Water District - well drilled 1979
3602781	Loma Linda University - well drilled 1980
3602791	Redlands, City of - well drilled 1980
3602792	Redlands, City of - well drilled 1981
3602793	Colton, City of - well drilled in 1981
3602799	East Valley Water District - well drilled 1981; formerly East San Bernardino County Water District
3602821	San Bernardino, City of - well drilled 1983, extractions verified during the 1986 verification
3602844	San Bernardino, City of - well drilled 1985, extractions verified during the 1986 verification
3602846	J.G. Golfing Enterprises, Inc. - formerly City of Riverside recordation no. 3601478

Historic Footnotes to Western San Bernardino Watermaster
Volume 1 - Verified Extraction by Non-Plaintiffs who have filed with SWRCB

Recordation Number	Description
3602848	Rialto, City of - well drilled 1985
3602855	Loma Linda University - well drilled 1986
3602895	Redlands, City of - well drilled 1986
3602896	Redlands, City of - well drilled 1986
3602897	West San Bernardino County Water District - well drilled 1987
3602917	Brookside Plaza - Well drilled in 1988
3603027	San Bernardino, City of - well drilled 1989
3603030	Rialto, City of - well drilled 1986, extractions commenced 1989
3603045	Redlands, City of - well drilled 1989
3603054	West San Bernardino County Water District - well drilled 1988
3603055	West San Bernardino County Water District - well drilled 1988
3603057	Loma Linda, City of - well drilled 1988
3603058	Loma Linda, City of - well drilled 1988
3603116	San Bernardino Valley MWD - well drilled 1989, formerly Big Bear Municipal Water District
3603141	San Bernardino Valley MWD - well drilled 1990
3603206	San Bernardino, City of - well drilled 1991
3603207	San Bernardino, City of - well drilled 1991
3603208	San Bernardino, City of - well drilled 1991
3603247	East Valley Water District - well drilled 1991
3603262	Holliday Trucking - well drilled 1991
3603471	San Bernardino, City of - well drilled 1992. extractions verified during 1993 verification
3603472	San Bernardino, City of - well drilled 1992. extractions verified during 1993 verification
3603523	Loma Linda, City of - well drilled 1992
3603538	Rialto, City of - well drilled 1993
3603539	Yucaipa Valley Water District - well drilled 1993
3603554	Barton Development - Well 3601748- refilled under 3603554 in 1993
3603579	San Bernardino, City of - well drilled 1994
3603580	San Bernardino, City of - well drilled 1994

Historic Footnotes to Western San Bernardino Watermaster
Volume 1 - Verified Extraction by Non-Plaintiffs who have filed with SWRCB

Recordation Number	
3603581	San Bernardino, City of - well drilled 1994
3603582	San Bernardino, City of - well drilled 1994
3603583	East Valley Water District - well drilled 1994
3603646	Inland Valley Development Agency - formerly Norton Air Force Base; Inland Valley Development Agency non-filed 0000086 prior to 1997
3603647	Inland Valley Development Agency - formerly Norton Air Force Base; Inland Valley Development Agency non-filed 0000087 prior to 1997
3603648	Inland Valley Development Agency - formerly Norton Air Force Base; Inland Valley Development Agency non-filed 0000089 prior to 1997
3603649	Inland Valley Development Agency - formerly Norton Air Force Base; Inland Valley Development Agency non-filed 0000090 prior to 1997
3603650	Inland Valley Development Agency - Well drilled 1997
3603653	Cemex Construction Materials Inc., well drilled in 1987, formerly Pharris Sand and Gravel, Southwest Materials
3603655	Redlands, City of - well drilled 1996
3603656	Redlands, City of - well drilled 1996
3603688	San Bernardino, City of - well first used 1998
3603689	San Bernardino, City of - well first used 1998
3603690	San Bernardino, City of - well first used 1998
3603691	San Bernardino, City of - well first used 1998
3603692	San Bernardino, City of - well first used 1998
3603693	San Bernardino, City of - well first used 1998
3603694	San Bernardino, City of - well first used 1998
3603695	Cal Mat Company - Extractions first verified in 1999
3603696	Cal Mat Company - Extractions first verified in 1999
3603697	Cal Mat Company - Extractions first verified in 1999
3603698	Payne,Larry (Owners #1) - Extraction first verified in 1999
3603699	Payne,Larry (Owners #2) - Extraction first verified in 1999
3603700	Payne,Larry (Owners #3) - Extraction first verified in 1999
3603704	Colton, City of (#26) - Extraction first verified in 1999
3603719	Loma Linda, City of (Mtn. View #3)- extractions first verified 1999
3603720	Loma Linda, City of (Richardson #4)- extractions first verified 2000
3603721	Loma Linda, City of (Mtn. View #4) - extractions first verified 2000
3603734	East Valley Water District (Plant 147) - extractions first verified in 2001

Historic Footnotes to Western San Bernardino Watermaster
Volume 1 - Verified Extraction by Non-Plaintiffs who have filed with SWRCB

Recordation Number	Description
3603760	Redlands, City of (Well 39) - extractions first verified in 2001
3603761	Redlands, City of (California Street Irrigation) - extractions first verified in 2001
3603762	Redlands, City of (Airport 2) - extractions first verified in 2001
3603766	Redlands, City of (North Orange #1) - Extraction first verified in 2003
3603767	Redlands, City of (North Orange #2) - Extraction first verified in 2003
3603769	West Valley Water District (Well #5A) - Extractions first verified in 2001
3603774	East Valley Water District (146A- 7938 Church Street)- Extraction first verified in 2003
3603776	Loma Linda, City of (Mtn. View #5) - Extraction first verified in 2003
3603777	West Valley Water District (Well #4A) - Extractions first verified in 2004
3603778	West Valley Water District (Well #8A) - Extractions first verified in 2004
3603786	San Bernardino, City of (EPA 108) - Extractions first verified in 2004
3603787	San Bernardino, City of (EPA 109) - Extractions first verified in 2004
3603788	San Bernardino, City of (EPA 110) - Extractions first verified in 2004
3603789	San Bernardino, City of (EPA 111) - Extractions first verified in 2004
3603790	San Bernardino, City of (EPA 112) - Extractions first verified in 2004
3603791	San Bernardino, City of (Kenwood 2) - Extractions first verified in 2004
3603792	San Bernardino, City of (Cajon 4) - Extractions first verified in 2004
3603795	Mountain View Power Company (MVL Mid-Aquifer #1) - Extractions first verified in 2005
3603796	Mountain View Power Company (MVL Mid-Aquifer #2) - Extractions first verified in 2005
3603900	San Bernardino County Flood Control (Domestic #3 - 7 Oaks Dam) - Extraction first verified in 2001
3603902	West Valley Water District (Well 1A) - Extractions first verified in 2007
3603904	East Valley Water District (Pl 132-5) - Extractions first verified in 2007
3603914	Colton, City of (Well #27), Extractions first verified in 2004
3603915	Colton, City of (Well #28), Extractions first verified in 2004
3603917	San Bernardino, City of (EPA 108S) - Extractions first verified in 2007
3603919	Calvary Chapel School (School Irrigation) - Extraction first verified in 2007
3603926	East Valley Water District (Well 151-Highland) - Extraction first verified in 2008
3603927	Loma Linda, City of (Richardson #6) - Extractions first verified in 2009
3603930	California State University, San Bernardino (Irrigation Well 1) - Extractions first verified in 2007

Historic Footnotes to Western San Bernardino Watermaster
Volume 1 - Verified Extraction by Non-Plaintiffs who have filed with SWRCB

Recordation Number	
3603932	San Bernardino County - Facility Management, County Hospital - Gilbert Street, was non-filer 0000019
3603933	San Bernardino County - Facility Management, Glen Helen #1A (2), was non-filer 0000177 Filing responsibility transfer to San Bernardino County - Regional Parks in 2010
3603934	San Bernardino County - Facility Management, Glen Helen #3, was non-filer 0000117
3603935	San Bernardino County - Facility Management, Glen Helen #4, was non-filer 0000118
3603936	San Bernardino County - Facility Management, Glen Helen #5, was non-filer 0000179
3603937	San Bernardino County - Facility Management, Glen Helen #6, was non-filer 0000180
3603938	Campus Crusade for Christ, West Twin Creek, Arrowhead Water and Power, was non-filer 0000155
3603943	Redland, City of, Weatherwax #2 - Extractions first verified in 2005
3603944	San Bernardino Valley Municipal Water District, De-Watering #1 - Extractions first verified in 2005
3603945	San Bernardino Valley Municipal Water District, De-Watering #2 - Extractions first verified in 2005
3603949	Montecito Memorial Park, Montecito #2 - older well, never reported, on common meter with 3600119
3604011	Mountain View Power Company (Aux #2a) - Extractions first verified in 2004, FC in 2005
3604012	Baseline Gardens Mutual Water Company (Well #4) - well drilled but never put into service
3690723	Southern California Edison Company - see also San Bernardino, City of 3600723
3690927	San Bernardino, City of (Patton 6) - shared extraction - see California Dept of Mental Health 3600927
3692174	East Valley Water District (PL 105) - shared extraction - Meyer

HISTORICAL FOOTNOTES - VERIFIED EXTRACTIONS
BY NON-PLAINTIFFS WHO HAVE NOT FILED WITH THE
STATE WATER RESOURCES CONTROL BOARD

Historic Footnotes to Western San Bernardino Watermaster
Volume 1 - Verified Extraction by Non-Plaintiffs who have not filed with SWRCB

Non Filer Number	
001	San Bernardino County - formerly Aerospace
017	Cliffside Ranch - commencing with 1978, filed by EVWD under recordation number 3602571 in Table 1
019	San Bernardino County - formerly County Hospital, became filer 3603932 in 2010
022	Daniels Harold - commencing in 1973, filed by Daniels and Best Ranch under recordation number 3602550 in Table 1
027	Texaco Gas Stations - formerly Douglas Gas Station
028	Saratoga Development Company - formerly East Highlands Orange Company then to East Highlands Ranch
029	East Highland Orange Company - commencing in 1980, filed by East Highlands Ranch Inc under recordation number 3602474 in Table 1
053	Quality Farms - formerly Rozema Chicken Ranch
054	Ellena, John B. - commencing in 1977, filed by the City of San Bernardino under recordation number 3602712, then transferred to CSUSB
059	East Valley Water District - was Hacienda Trailer Park
072	Inter City Mutual Water Company - commencing in 1997, filed by the City of San Bernardino under recordation number 3602521 in Table 1
076	East Valley Water District - was Lankershim Mutual Water Company
080	L.P.R. Ranch - commencing in 1972, filed L.P.R. Ice Company under recordation number 3602525 in Table 1
082	Baseline Laundry - formally Meeks and Daley
083	Mentone Domestic Water Company - commencing in 1978, filed by the City of Redlands under recordation number 3602653 in Table 1
086	Inland Valley Development Agency, see Table 1 commencing 1997
087	Inland Valley Development Agency, see Table 1 commencing 1997
088	Inland Valley Development Agency, formerly Norton Air Force Base
089	Inland Valley Development Agency, see Table 1 commencing 1997
090	Inland Valley Development Agency, see Table 1 commencing 1997
091	Inland Valley Development Agency, formerly Norton Air Force Base
092	Inland Valley Development Agency, formerly Norton Air Force Base
093	Inland Valley Development Agency, formerly Norton Air Force Base
094	Inland Valley Development Agency, formerly Norton Air Force Base
097	Pierson - Well destroyed
100	Redlands Associates - commencing in 1972, filed by Blue Goose Growers Inc. under recordation number 3602529 in Table 1
101	Redlands Associates - commencing in 1972, filed by Blue Goose Growers Inc. under recordation number 3602530 in Table 2
102	Redlands Associates - commencing in 1980, filed by Blue Goose Growers Inc. under recordation number 3602531 in Table 3
103	Redlands, City of - commencing in 1974, see Table #5, Mill Creek verification of extractions, Mill Creek Ranger Station terminated May 1979
104	Redlands Water Company - commencing in 1974, see Table #6, Santa Ana River verification of Extractions
117	San Bernardino County Glen Helen 3, Became filer 3603934 in 2010

Historic Footnotes to Western San Bernardino Watermaster
Volume 1 - Verified Extraction by Non-Plaintiffs who have not filed with SWRCB

Non Filer Number	
118	San Bernardino County Glen Helen 4, Became filer 3603935 in 2010
122	Seley - original verification done during the 1993 verification
126	Smith Meat Packing Plant - well destroyed
127	Stanley, Silas - 1982 verified amount corrected during 1983 verification
134	Triple Falls Mutual Water Company - commencing in 1975, file by Yucaipa Valley Water District under recordation number 3602659 in Table 1
135	Triple Falls Mutual Water Company - commencing in 1975, file by Yucaipa Valley Water District under recordation number 3602658 in Table 1
136	Triple Falls Mutual Water Company - commencing in 1975, file by Yucaipa Valley Water District under recordation number 3602657 in Table 1
139	University of Redlands - Formerly Karahalois
144	Victoria Seventh Day Adventist - formerly Ed Vanleuven
145	Mt. View Child Care Center - formerly Vanleuven Nursing Home
155	Arrowhead Power and Water - Formerly Campus Crusade for Christ, West Twin Creek Water Company, Warner Hodgdon
160	San Manuel Indian Reservation - formerly York
161	San Manuel Indian Reservation - formerly York
162	San Manuel Indian Reservation - formerly York
163	Patterson, Roy H. - formerly Dr. G. Roberts
175	Daniels Don - commencing in 1973, filed by Daniels and Best Ranch under recordation number 3602549 in Table 1
176	Mentone Domestic Water Company - commencing in 1975, filed by the City of Redlands under recordation number 3602654 in Table 2
177	San Bernardino County - Glen Helen 1A, original verification done during the 1973 verification, became filer 3603936 in 2010
178	Kuhn, Richard J - well drilled in 1976
179	San Bernardino, County of - Glen Helen #5, became filer 3603936 in 2010
180	San Bernardino, County of - Glen Helen #6, became filer 3603937 in 2010
181	Unknown - Foisty Street

TABLE NO. 1

EXTRACTIONS BY OWNERS (NON-PLAINTIFFS) WHICH
HAVE RECORDATION FILINGS WITH THE
STATE WATER RESOURCES CONTROL BOARD

WESTERN - SAN BERNARDINO WATERMASTER
TABLE 1

VERIFIED EXTRACTIONS - FILED
SAN BERNARDINO BASIN AREA

RECRD TN NUMBER	STATE WELL NUMBER	WELL LOCAL TYPE DESIGNATION	FC	-----BASE YEARS-----							-----CALENDAR YEAR EXTRACTIONS-----				
				1959	1960	1961	1962	1963	AVG	2008	2009	2010	2011	2012	AVG
7TH AVE WELL															
3601121	01S/02W-31F	W 1	<input checked="" type="checkbox"/>	230	342	514	161	271	304		0	0	0	0	0
TOTALS FOR 7TH AVE WELL														304	
ARMSTRONG, DOUGLAS															
3600076	01S/03W-17G	W 2	<input checked="" type="checkbox"/>	286	342				126		0	0	0	0	0
TOTALS FOR ARMSTRONG, DOUGLAS														126	
ARROWHEAD COUNTRY CLUB															
3601925	01N/04W-23E	W 1	<input type="checkbox"/>	600	607	650	650	650	631		531	472	396	385	433
TOTALS FOR ARROWHEAD COUNTRY CLUB														631	
ARROYO VERDE MUTUAL WATER COMPANY															
3602068	01S/04W-01A02S	W	<input checked="" type="checkbox"/>	166	186	162	168	141	165		0	0	0	0	0
3602069	01S/04W-01A	W	<input checked="" type="checkbox"/>						0		0	0	0	0	0
TOTALS FOR ARROYO VERDE MUTUAL WATER COMPANY														165	
ATCHISON TOPEKA & SANTA FE RAILWAY															
3600178	01S/04W-08F02S	W 3	<input checked="" type="checkbox"/>	158	127	113	110	69	115		0	0	0	0	0
3600179	01S/04W-08F	W 4	<input checked="" type="checkbox"/>	158	127	113	110	69	115		0	0	0	0	0
TOTALS FOR ATCHISON TOPEKA & SANTA FE RAILWAY														231	
B M I FUNDS															
3600107	01S/03W-21P01S	W COLTON 1	<input checked="" type="checkbox"/>	343	323	165	165	165	199		0	0	0	0	0
TOTALS FOR B M I FUNDS														199	
BARNO, JOHN															
3602079	01S/03W-03F	W 1	<input checked="" type="checkbox"/>					34	7		0	0	0	0	0
TOTALS FOR BARNO, JOHN														7	
BARTON DEVELOPMENT															
3601748	01S/03W-18H01S	W CALIF	<input checked="" type="checkbox"/>	1,133	1,622	1,145	300	475	935		0	0	0	0	0
3601748-	01S/03W-19A01S	W CALIF	<input checked="" type="checkbox"/>					0	0		0	0	0	0	0

WESTERN - SAN BERNARDINO WATERMASTER

TABLE 1

VERIFIED EXTRACTIIONS - FILED
SAN BERNARDINO BASIN AREA

RECRD TN NUMBER	STATE WELL NUMBER	WELL LOCAL TYPE DESIGNATION	FC	-----BASE YEARS-----							-----CALENDAR YEAR EXTRACTIIONS-----							
				1959	1960	1961	1962	1963	1963	1963	1963	1963	1963	2008	2009	2010	2011	2012
TOTALS FOR BARTON DEVELOPMENT				1,133	1,622	1,145	300	475	935	0	0	0	0	0	0	0	0	0
BARTON DEVELOPMENT C/O LUCKY FARMS																		
3600418	01S/03W-19G	W LUGONIA	<input type="checkbox"/>	182	173	116	66	57	119	256	280	259	252	250	259	259		
3603554	01S/03W-19A01S	W CALIF ST	<input type="checkbox"/>						0	379	215	345	336	194	294	294		
TOTALS FOR BARTON DEVELOPMENT C/O LUCKY FARMS				182	173	116	66	57	119	635	495	604	588	444	444	553	553	
BASE LINE WELL COMPANY																		
3600456	01N/03W-33R02S	W 1	<input checked="" type="checkbox"/>	0	0	0	0	0	0	0	0	0	0	0	0	0	0	
TOTALS FOR BASE LINE WELL COMPANY				0	0	0	0	0	0	0	0	0	0	0	0	0	0	0
BASELINE GARDENS MUTUAL WATER COMPANY																		
3600457	01N/04W-35J02S	W 1 STANDBY	<input checked="" type="checkbox"/>	28	28	28	28	28	28	28	0	0	0	0	0	0	0	
3600458	01N/04W-36M01S	W PS & B 2	<input type="checkbox"/>	275	275	275	275	275	275	275	0	0	0	0	0	0	0	
3602528	01N/04W-35R01S	W #3-7251 BARTON ST	<input type="checkbox"/>						0	424	336	217	0	0	195	195		
3604012	01N/04W-35R	W WELL #4	<input type="checkbox"/>						0	0	0	0	0	0	0	0	0	
TOTALS FOR BASELINE GARDENS MUTUAL WATER COMPANY				303	303	303	303	303	303	424	336	217	0	0	195	195		
BEAR VALLEY MUTUAL WATER COMPANY																		
3600021	01N/02W-26H	W SANTA A1	<input type="checkbox"/>	687	556	465	555	532	559	182	0	0	0	0	0	0	36	
3600022	01N/02W-26H	W SA #2	<input checked="" type="checkbox"/>	531	522	351	472	458	467	0	0	0	0	0	0	0	0	
3600023	01S/03W-24C	W JUDSON1	<input type="checkbox"/>	1,780	1,845	2,434	1,726	1,444	1,846	0	0	0	0	0	0	0	0	
3600024	01S/02W-19D	W WABASH 2	<input checked="" type="checkbox"/>	0	219	163	32	8	84	0	0	0	0	0	0	0	0	
3600025	01N/03W-29R01S	W PALM AV3	<input checked="" type="checkbox"/>	0	0	170	0	0	34	0	0	0	0	0	0	0	0	
3600027	01N/02W-10N	D	<input checked="" type="checkbox"/>	266	170	196	180	106	184	0	0	0	0	0	0	0	0	
3600028	01S/02W-04N	D SANTA ANA RIVER M	<input type="checkbox"/>	19,622	15,927	11,418	13,528	10,836	14,266	13,519	10,368	17,524	16,862	15,560	14,767	14,767		
3601585	01S/03W-23A03S	W SBDNO AV 1 NELSON	<input type="checkbox"/>	0	0	1,012	974	882	574	0	0	0	0	0	0	0	0	
TOTALS FOR BEAR VALLEY MUTUAL WATER COMPANY				22,886	19,239	16,209	17,467	14,266	18,013	13,701	10,368	17,524	16,862	15,560	14,803	14,803		
BELL, EUGENE																		
3600449	01S/03W-20A	W CALVARY CHAPEL	<input type="checkbox"/>	115	88	30	85	167	97	108	139	73	20	1	68	68		
TOTALS FOR BELL, EUGENE				115	88	30	85	167	97	108	139	73	20	1	68	68		

WESTERN - SAN BERNARDINO WATERMASTER

TABLE 1

VERIFIED EXTRACTIONS - FILED
SAN BERNARDINO BASIN AREA

RECRD TN NUMBER	STATE WELL NUMBER	WELL LOCAL TYPE DESIGNATION	FC	-----BASE YEARS-----							AVG	-----CALENDAR YEAR EXTRACTIONS-----																									
				1959	1960	1961	1962	1963	1963	1963		2008	2009	2010	2011	2012	AVG																				
BERMAN, BUD																																					
3602007	01S/04W-02K	W 2	<input checked="" type="checkbox"/>				28	32		12		5	0	0	0	0	0	0	0	0	0	0	0	1													
TOTALS FOR BERMAN, BUD																	28	32		12		5	0	0	0	0	0	0	0	0	0	0	1				
BLUE BANNER COMPANY																																					
3602531	01S/02W-09L03S	W TUNNEL DIV	<input type="checkbox"/>							0		100	100	100	100	100	100	100	100	100	100	100	50	90													
TOTALS FOR BLUE BANNER COMPANY																			0		100	100	100	100	100	100	100	100	100	100	100	50	90	90			
BLUE GOOSE GROWERS INC																																					
3602529	01S/02W-09P02S	W GRNSPOT 6	<input checked="" type="checkbox"/>							0		0	0	0	0	0	0	0	0	0	0	0	0	0													
3602530	01S/02W-09L02S	W BLOCK 11	<input checked="" type="checkbox"/>							0		0	0	0	0	0	0	0	0	0	0	0	0	0													
TOTALS FOR BLUE GOOSE GROWERS INC																			0		0	0	0	0	0	0	0	0	0	0	0	0	0	0			
BRISTOL RANCH																																					
3601631	01N/03W-34C02S	W 1	<input checked="" type="checkbox"/>	90	100	160	108	108		113		0	0	0	0	0	0	0	0	0	0	0	0	0													
TOTALS FOR BRISTOL RANCH														90	100	160	108	108		113		113		0	0	0	0	0	0	0	0	0	0	0	0	0	0
BROOKSIDE DAIRY INC																																					
3600036	01S/03W-33D	W 1	<input checked="" type="checkbox"/>	302	302	312	312	313		308		0	0	0	0	0	0	0	0	0	0	0	0	0													
TOTALS FOR BROOKSIDE DAIRY INC														302	302	312	312	313		308		308		0	0	0	0	0	0	0	0	0	0	0	0	0	
BROOKSIDE PLAZA																																					
3602917	01S/03W-33D01S	W STATER BROS PLAZA	<input type="checkbox"/>							0		14	14	14	13	7	13	13	12	12	12	12	12	12													
TOTALS FOR BROOKSIDE PLAZA																			0		14	14	13	7	13	13	12	12	12	12	12	12	12	12	12		
BUOYE WELL																																					
3602062	01S/02W-29N	W 1	<input checked="" type="checkbox"/>	0	0	146	160	177		97		0	0	0	0	0	0	0	0	0	0	0	0	0													
TOTALS FOR BUOYE WELL														0	0	146	160	177		97		97		0	0	0	0	0	0	0	0	0	0	0	0	0	
CALIF DEPT OF MENTAL HEALTH- PLANT OPERATIONS																																					
3600923	01N/03W-32C01S	W PATTON 1	<input checked="" type="checkbox"/>	211	286	257	218	212		237		0	0	0	0	0	0	0	0	0	0	0	0	0													
3600924	01N/03W-29M01S	W PATTON 2	<input checked="" type="checkbox"/>	175	223	146	156	143		169		0	0	0	0	0	0	0	0	0	0	0	0	0													
3600924-	01N/03W-29M	W 2A	<input type="checkbox"/>							0		155	25	1	5	11	39	39	39	39	39	39	39	39													
3600929	01N/03W-31K02S	W PATTON 8	<input checked="" type="checkbox"/>	41				0		8		0	0	0	0	0	0	0	0	0	0	0	0														

WESTERN - SAN BERNARDINO WATERMASTER
TABLE 1

VERIFIED EXTRACTIONS - FILED
SAN BERNARDINO BASIN AREA

RECRD TN NUMBER	STATE WELL NUMBER	WELL LOCAL TYPE DESIGNATION	FC	-----BASE YEARS-----							-----CALENDAR YEAR EXTRACTIONS-----						
				1959	1960	1961	1962	1963	AVG	2008	2009	2010	2011	2012	AVG		
3600931	01N/03W-29N01S	W PATTON10	<input type="checkbox"/>	520	227	282	303	307	328	0	0	0	0	0	0	0	
3601930	01N/03W-32C02S	W PATTON11	<input checked="" type="checkbox"/>	340	400	400	326	295	272	0	0	0	0	0	0	0	
3602381	01N/03W-29M	W 14	<input type="checkbox"/>						0	43	28	0	0	0	0	14	
TOTALS FOR CALIF DEPT OF MENTAL HEALTH- PLANT OPERAT				947	1,076	1,085	1,003	957	1,014	198	53	1	5	11	54		
CALIFORNIA STATE UNIVERSITY, SAN BERNARDINO																	
3602712	01N/04W-08P01S	W ELLENA BROS.	<input type="checkbox"/>						0	0	0	0	0	0	0	0	
3603930	01N/04W-17A01S	W IRRIGATION WELL 1	<input type="checkbox"/>						0	208	185	162	165	165	185	181	
TOTALS FOR CALIFORNIA STATE UNIVERSITY, SAN BERNARDI									0	208	185	162	165	165	185	181	
CALVARY CHAPEL SCHOOL																	
3603919	01S/03W-20A03S	W SCHOOL IRRIGATION	<input type="checkbox"/>						0	10	10	10	10	85	85	40	
TOTALS FOR CALVARY CHAPEL SCHOOL									0	10	10	10	10	85	85	40	
CAMPUS CRUSADE FOR CHRIST																	
3601811	01N/04W-14A	D EAST TWIN	<input type="checkbox"/>	400	300	302	272	211	297	3	0	0	0	0	0	1	
3601979	01N/04W-14A	D EAST TWIN	<input checked="" type="checkbox"/>	146	146	146	146	146	146	0	0	0	0	0	0	0	
3603938	01N/04W-14C	D WEST TWIN CRK	<input type="checkbox"/>	200	200	150	150	50	150	40	40	40	40	40	40	40	
TOTALS FOR CAMPUS CRUSADE FOR CHRIST				746	646	598	568	407	593	43	40	40	40	40	40	41	
CANYON RANCH																	
3600160	01S/03W-32G01S	W GUNTER	<input type="checkbox"/>	200	200	200	200	200	200	0	0	0	0	0	0	0	
TOTALS FOR CANYON RANCH				200	200	200	200	200	200	0	0	0	0	0	0	0	0
CARDIFF FARMS MUTUAL WATER COMPANY																	
3600973	01S/04W-12D	W 1	<input checked="" type="checkbox"/>	445	391	432	339	384	398	0	0	0	0	0	0	0	
3601619	01S/04W-12D	W 2	<input checked="" type="checkbox"/>	73	64	70	64	62	67	0	0	0	0	0	0	0	
TOTALS FOR CARDIFF FARMS MUTUAL WATER COMPANY				518	455	502	403	446	465	0	0	0	0	0	0	0	
CARTER, JAMES																	
3602241	01S/03W-20F03S	W ALMOND	<input checked="" type="checkbox"/>	25	25	25	27	8	22	0	0	0	0	0	0	0	
TOTALS FOR CARTER, JAMES				25	25	25	27	8	22	0	0	0	0	0	0	0	

WESTERN - SAN BERNARDINO WATERMASTER

TABLE 1

VERIFIED EXTRACTIONS - FILED
SAN BERNARDINO BASIN AREA

RECRD TN NUMBER	STATE WELL NUMBER	WELL LOCAL TYPE DESIGNATION	FC	-----BASE YEARS-----							-----CALENDAR YEAR EXTRACTIONS-----						
				1959	1960	1961	1962	1963	AVG	2008	2009	2010	2011	2012	AVG		
CEMEX CONSTRUCTION MATERIALS PACIFIC, LLC																	
3601420	01S/03W-09E	W ALABAMA 2	<input type="checkbox"/>	221	225	220	293	295	251	184	174	174	174	184	178		
3603653	01S/03W-10J	W ORANGE STREET	<input type="checkbox"/>						0	127	79	12	0	0	44		
TOTALS FOR CEMEX CONSTRUCTION MATERIALS PACIFIC, LL				221	225	220	293	295	251	311	253	186	174	184	222		
CHARLES, J. J.																	
3600815	01S/03W-06L	W	<input checked="" type="checkbox"/>	0	0	0	0	0	0	0	0	0	0	0	0		
TOTALS FOR CHARLES, J. J.				0	0	0	0	0	0	0	0	0	0	0	0		
CITY CREEK WATER COMPANY																	
3600681	01N/03W-27M	D CITY CREEK	<input checked="" type="checkbox"/>	123	51	7	64	30	55	0	0	0	0	0	0		
TOTALS FOR CITY CREEK WATER COMPANY				123	51	7	64	30	55	0	0	0	0	0	0		
COGBILL, CLINTON L.																	
3601628	01S/02W-09Q	W 2	<input type="checkbox"/>	312	296	325	181	91	241	50	50	50	50	50	50		
TOTALS FOR COGBILL, CLINTON L.				312	296	325	181	91	241	50	50	50	50	50	50		
COLTON, CITY OF																	
3601250	01S/04W-08F10S	W 4	<input checked="" type="checkbox"/>	326	132	102	133	121	163	0	0	0	0	0	0		
3601251	01S/04W-08R05S	W 5	<input checked="" type="checkbox"/>	0	101	233	578	227	228	0	0	0	0	0	0		
3601252	01S/04W-05R	W 6	<input checked="" type="checkbox"/>	463	733	129	154	62	308	0	0	0	0	0	0		
3601253	01S/04W-08Q01S	W 7	<input type="checkbox"/>	376	526	364	339	189	359	0	0	0	0	0	0		
3601254	01S/04W-08F08S	W 8	<input type="checkbox"/>	111	172	257	378	651	314	0	0	0	0	0	0		
3601256	01S/04W-09N	W PLUNGE12	<input checked="" type="checkbox"/>	114	79	77	13	11	59	0	0	0	0	0	0		
3601257	01S/04W-08F07S	W 13	<input type="checkbox"/>	786	519	726	861	919	762	804	677	781	876	656	759		
3601258	01S/04W-08R	W 14	<input checked="" type="checkbox"/>	10	4	163	228	210	123	0	0	0	0	0	0		
3601260	01S/04W-08F01S	W 16	<input type="checkbox"/>	628	1,066	967	689	595	789	449	0	287	656	836	446		
3601262	01S/04W-08C02S	W BARNHL 18	<input checked="" type="checkbox"/>	0	274	287	370	282	243	0	0	0	0	0	0		
3602405	01S/04W-08C04S	W 19	<input type="checkbox"/>						0	997	1,103	554	897	884	887		
3602498	01S/04W-08R07S	W NO 6B	<input checked="" type="checkbox"/>						0	0	0	0	0	0	0		
3602793	01S/04W-08F15S	W WELL 21	<input type="checkbox"/>						0	1,797	1,816	1,032	1,438	1,879	1,592		
3603704	01S/04W-08J02S	W 26	<input type="checkbox"/>						0	551	609	468	735	648	602		
3603914	01S/04W-08J03S	W #27	<input type="checkbox"/>						0	1,698	1,733	1,159	181	1,021	1,158		

WESTERN - SAN BERNARDINO WATERMASTER
TABLE 1

VERIFIED EXTRACTIIONS - FILED
SAN BERNARDINO BASIN AREA

RECRD TN NUMBER	STATE WELL NUMBER	WELL LOCAL TYPE DESIGNATION	FC	-----BASE YEARS-----					-----CALENDAR YEAR EXTRACTIIONS-----								
				1959	1960	1961	1962	1963	AVG	2008	2009	2010	2011	2012	AVG		
3603915	01S/04W-08F17S	W #28	<input type="checkbox"/>	2,814	3,606	3,305	3,743	3,267	3,347	0	621	396	459	0	298	355	
TOTALS FOR COLTON, CITY OF											6,917	6,334	4,740	4,783	6,222	5,799	
CONEJO RANCHOS MUTUAL WATER COMPANY																	
3601186	01N/04W-36F03S	W 1	<input checked="" type="checkbox"/>	0	0	0	0	0	0	0	0	0	0	0	0	0	
TOTALS FOR CONEJO RANCHOS MUTUAL WATER COMPANY																	
CRAFTON WATER COMPANY																	
3600272	01S/02W-29N	W 5TH AVE, # 1	<input type="checkbox"/>	623	750	854	483	477	637	684	530	99	10	14	267		
3600313	01S/02W-29N01S	W NYE	<input checked="" type="checkbox"/>	164	199	294	156	167	196	0	0	0	0	0	0	0	
3602186	01S/02W-21L02S	W 2-GARNET/ZANJA	<input type="checkbox"/>		57	262	181	100	933	684	530	99	10	14	267		
TOTALS FOR CRAFTON WATER COMPANY				787	949	1,205	901	825									
GRAM-PATTERSON WELL																	
3600188	01S/02W-16C	W CRAMPAT2	<input type="checkbox"/>	413	257	361	277	294	320	531	596	415	415	534	498		
TOTALS FOR GRAM-PATTERSON WELL				413	257	361	277	294	320	531	596	415	415	534	498		
DANGERMOND, JACK																	
3602188	01S/02W-29L	W RANCHO LADERA-ES	<input type="checkbox"/>	162	148	331	206	313	232	215	333	0	0	0	110		
TOTALS FOR DANGERMOND, JACK				162	148	331	206	313	232	215	333	0	0	0	110		
DANIELS RANCH																	
3602550	01S/03W-17R04S	W ALABAMA ST	<input checked="" type="checkbox"/>						0	0	0	0	0	0	0	0	
TOTALS FOR DANIELS RANCH									0	0	0	0	0	0	0	0	
DEER PARK LLC																	
3601632	02S/03W-05A02S	W CLOCK CYN	<input type="checkbox"/>	104	85	105	88	87	94	0	0	0	0	0	0	0	
TOTALS FOR DEER PARK LLC				104	85	105	88	87	94	0	0	0	0	0	0	0	0
DEL ROSA MUTUAL WATER COMPANY																	
3601809	01N/04W-26H	W GOLDNAV1	<input checked="" type="checkbox"/>	94	100	561	529	284	314	0	0	0	0	0	0	0	
3601810	01N/04W-23E	W PRKSDS 2	<input checked="" type="checkbox"/>	231	200	9	0	0	88	0	0	0	0	0	0	0	
TOTALS FOR DEL ROSA MUTUAL WATER COMPANY				325	300	570	529	284	402	0	0	0	0	0	0	0	0

WESTERN - SAN BERNARDINO WATERMASTER
TABLE 1

VERIFIED EXTRACTIONS - FILED
SAN BERNARDINO BASIN AREA

RECRD TN NUMBER	STATE WELL NUMBER	WELL LOCAL TYPE DESIGNATION	FC	-----BASE YEARS-----							-----CALENDAR YEAR EXTRACTIONS-----						
				1959	1960	1961	1962	1963	AVG	2008	2009	2010	2011	2012	AVG		
DEVORE WATER COMPANY																	
3602382	02N/05W-28D	W 1	<input checked="" type="checkbox"/>	0	0	0	0	0	0	0	0	0	0	0	0		
3602383	02N/05W-28C02S	W 2A	<input type="checkbox"/>	35	57	80	15	32	44	118	137	62	71	131	104		
3602384	02N/05W-28C03S	W 3	<input type="checkbox"/>				5	17	4	93	111	69	0	121	79		
3602385	02N/05W-20H	W MIDDLEMAN FALLS C	<input type="checkbox"/>	2	2	2	3	3	2	9	8	8	8	9	11		
3602386	02N/05W-21E	W LETHIN SP	<input type="checkbox"/>	9	7	6	11	9	8	46	31	53	66	50	49		
3602387	02N/05W-22E	D E KIMBARK	<input type="checkbox"/>	35	27	22	42	31	31	68	48	61	75	35	57		
3602388	02N/05W-21G	W KIMBARK	<input type="checkbox"/>	45	36	30	56	44	42	241	171	292	337	155	239		
3602389	02N/05W-22N	D HOPPER	<input checked="" type="checkbox"/>	0	0	0	0	0	0	0	0	0	0	0	0		
3602390	02N/05W-28B	D SANTA FE	<input checked="" type="checkbox"/>	0	0	0	0	0	0	0	0	0	0	0	0		
3602391	02N/05W-28D	D CASADY	<input checked="" type="checkbox"/>	0	0	0	0	0	0	0	0	0	0	0	0		
3602428	02N/05W-33E01S	W 4	<input type="checkbox"/>						0	31	36	25	22	32	29		
TOTALS FOR DEVORE WATER COMPANY				126	129	140	132	136	133	606	542	570	580	535	567		
DUCKWORTH, JOHN E.																	
3600765	01N/03W-33C01S	W 113	<input type="checkbox"/>	252	243	353	250	244	268	1	0	0	0	0	0		
TOTALS FOR DUCKWORTH, JOHN E.				252	243	353	250	244	268	1	0	0	0	0	0		
EAST BARTON WATER COMPANY																	
3600608	01S/03W-28E01S	W BARTON	<input checked="" type="checkbox"/>	168	127	135	274	145	170	0	0	0	0	0	0		
TOTALS FOR EAST BARTON WATER COMPANY				168	127	135	274	145	170	0	0	0	0	0	0		
EAST HIGHLAND RANCH																	
3600598	01S/03W-02L	W NEW 1	<input checked="" type="checkbox"/>	1,116	1,071	1,166	1,111	1,071	1,107	0	0	0	0	0	0		
3600604	01S/02W-07B	W RANNEY	<input checked="" type="checkbox"/>	315	325	0	67	0	141	0	0	0	0	0	0		
3600605	01N/03W-35G	D PLUNGE CK	<input type="checkbox"/>	757	430	399	828	662	615	0	0	0	0	0	0		
3600606	01N/03W-35K	D ELDER GULCH	<input type="checkbox"/>	135	135	135	135	135	135	0	0	0	0	0	0		
3600607	01S/03W-02L01S	W SMALL	<input checked="" type="checkbox"/>	955	900	990	945	875	933	0	0	0	0	0	0		
3600607-	01S/03W-02L02S	W WELL 3	<input checked="" type="checkbox"/>						0	0	0	0	0	0	0		
3602474	01N/03W-25Q	D PLUNGE/BOX SPRING	<input checked="" type="checkbox"/>						0	0	0	0	0	0	0		
TOTALS FOR EAST HIGHLAND RANCH				3,278	2,861	2,690	3,086	2,743	2,932	0	0	0	0	0	0		

WESTERN - SAN BERNARDINO WATERMASTER
TABLE 1

VERIFIED EXTRACTIONS - FILED
SAN BERNARDINO BASIN AREA

RECRD TN NUMBER	STATE WELL NUMBER	WELL LOCAL TYPE DESIGNATION	FC	-----BASE YEARS-----							-----CALENDAR YEAR EXTRACTIONS-----						
				1959	1960	1961	1962	1963	AVG	2008	2009	2010	2011	2012	AVG		
EAST PIONEER MUTUAL WELL COMPANY																	
3602224	01S/03W-13P	W	<input checked="" type="checkbox"/>	776	692	876	403	431	636								
TOTALS FOR EAST PIONEER MUTUAL WELL COMPANY																	
				776	692	876	403	431	636								
EAST VALLEY WATER DISTRICT																	
3600058	01S/03W-03F02S	W	<input checked="" type="checkbox"/>	178	160	130	124	28	124								
3600183	01S/04W-02A	W	<input checked="" type="checkbox"/>	75	70	69	28	28	54								
3600220	01S/03W-01H01S	W	<input type="checkbox"/>	753	874	303	371	310	522	425	445	624	503	600	519		
3600221	01N/03W-30J	W	<input checked="" type="checkbox"/>	413	339	339	415	498	401								
3600269	01N/03W-31L01S	W	<input checked="" type="checkbox"/>	40	33	62	53	4	38								
3600275	01N/03W-32B	W	<input checked="" type="checkbox"/>	126	126	159	170	0	116								
3600374	01N/03W-33M01S	W	<input checked="" type="checkbox"/>	81	105	186	45	102	104								
3600375	01S/03W-05D	W	<input checked="" type="checkbox"/>	170	198	234	155	195	190								
3600376	01S/03W-05D03S	W	<input type="checkbox"/>	238	174	240	379	281	262								
3600377	01N/03W-27N08S	W	<input checked="" type="checkbox"/>	103	11	0	1	0	23								
3600378	01N/03W-27N02S	W	<input checked="" type="checkbox"/>	278	330	201	196	136	228								
3600444	01N/03W-30H01S	W	<input type="checkbox"/>	115	174	302	383	204	236								
3600466	01S/03W-04C	W	<input checked="" type="checkbox"/>	318	248	316	225	244	270								
3600545	01N/03W-30J	W	<input checked="" type="checkbox"/>	208	174	141	174	3	140								
3600643	01N/04W-25K01S	W	<input checked="" type="checkbox"/>	21	14	12	10	11	11								
3600680	01S/03W-02J02S	W	<input type="checkbox"/>	789	573	715	533	593	641	1,482	500	0	0	0	396		
3600855	01N/03W-28PO1S	W	<input type="checkbox"/>						0								
3600864	01N/03W-19F	W	<input checked="" type="checkbox"/>	1					0								
3600925	01S/04W-01Q01S	W	<input checked="" type="checkbox"/>	384	258	244	292	151	266								
3600926	01S/04W-01F02S	W	<input checked="" type="checkbox"/>	368	441	512	441	490	450								
3600927	01N/03W-31B01S	W	<input checked="" type="checkbox"/>	399	401	259	301	242	320								
3600928	01N/03W-31L02S	W	<input checked="" type="checkbox"/>	0	114	229	200	152	139								
3600930	01N/03W-31L03S	W	<input checked="" type="checkbox"/>	206	133	114	214	110	155								
3600970	01N/03W-19G	W	<input checked="" type="checkbox"/>	20	20	15	10	10	15								
3600971	01N/03W-19F	W	<input checked="" type="checkbox"/>	49	49	49	49	49	49								
3601069	01N/03W-33M02S	W	<input checked="" type="checkbox"/>	86	28	61	148	144	93								
3601184	01N/03W-33F01S	W	<input type="checkbox"/>	229	485	573	575	497	472								

WESTERN - SAN BERNARDINO WATERMASTER
 TABLE 1
 VERIFIED EXTRACTIONS - FILED
 SAN BERNARDINO BASIN AREA

RECRD TN NUMBER	STATE WELL NUMBER	WELL LOCAL TYPE DESIGNATION	FC	-----BASE YEARS-----											-----CALENDAR YEAR EXTRACTIONS-----								
				1959	1960	1961	1962	1963	AVG	2008	2009	2010	2011	2012	AVG								
3601582	01S/04W-02R	W PL 119	✓	209	161	154	153	153	166	0	0	0	0	0	0	0	0	0	0	0	0	0	0
3601584	01N/03W-33H01S	W PL 47	✓	84	77	75	54	44	67	0	0	0	0	0	0	0	0	0	0	0	0	0	0
3601639	01S/03W-03R02S	W PL 146 / 2		841	944	1,116	1,095	1,111	1,021	218	184	308	178	336	178	245	0	0	0	0	0	0	0
3601643	01S/03W-03R01S	W PL 121	✓	0	0	1,411	1,286	1,064	752	0	0	0	0	0	0	0	0	0	0	0	0	0	0
3601653	01N/04W-36K04S	W PL 1	✓	0	0	0	0	0	0	0	0	0	0	0	0	0	0	0	0	0	0	0	0
3601654	01N/04W-36K	W PL 1A / FISHER	✓	10	0	0	0	0	2	0	0	0	0	0	0	0	0	0	0	0	0	0	0
3601655	01N/04W-36K05S	W PL 2	✓	0	0	0	0	0	0	0	0	0	0	0	0	0	0	0	0	0	0	0	0
3601656	01N/04W-36Q01S	W PL 6	✓	0	0	2	28	0	6	0	0	0	0	0	0	0	0	0	0	0	0	0	0
3601657	01S/04W-01B04S	W PL 7	✓	0	60	21	17	67	33	0	0	0	0	0	0	0	0	0	0	0	0	0	0
3601658	01N/04W-36R10S	W PL 8	✓	0	0	0	0	0	0	0	0	0	0	0	0	0	0	0	0	0	0	0	0
3601659	01S/03W-06H01S	W PL 9	✓	0	0	0	0	0	0	0	0	0	0	0	0	0	0	0	0	0	0	0	0
3601660	01S/03W-06H04S	W PL 9A		260	572	803	543	771	590	1,224	737	934	813	683	878	0	0	0	0	0	0	0	0
3601661	01S/04W-01J08S	W PL 10	✓	0	0	0	0	0	0	0	0	0	0	0	0	0	0	0	0	0	0	0	0
3601662	01S/04W-02Q05S	W PL 11	✓	739	556	541	407	487	546	0	0	0	0	0	0	0	0	0	0	0	0	0	0
3601663	01S/04W-02Q04S	W PL 12		257	284	279	265	204	258	0	0	0	0	0	0	0	0	0	0	0	0	0	0
3601664	01S/04W-02N01S	W PL 13	✓	0	0	0	0	0	0	0	0	0	0	0	0	0	0	0	0	0	0	0	0
3601665	01S/04W-01K04S	W PL 14		254	423	382	153	33	249	0	0	0	0	0	0	0	0	0	0	0	0	0	0
3601666	01N/04W-36F08S	W PL 16	✓	0	0	0	0	0	0	0	0	0	0	0	0	0	0	0	0	0	0	0	0
3601667	01S/03W-06A05S	W PL 21	✓	0	0	0	0	0	0	0	0	0	0	0	0	0	0	0	0	0	0	0	0
3601668	01S/04W-01E02S	W PL 22	✓	68	92	82	104	217	113	0	0	0	0	0	0	0	0	0	0	0	0	0	0
3601669	01N/04W-36H06S	W PL 23	✓	0	0	0	0	0	0	0	0	0	0	0	0	0	0	0	0	0	0	0	0
3601670	01N/04W-26A10S	W PL 24	✓	252	261	264	332	168	255	0	0	0	0	0	0	0	0	0	0	0	0	0	0
3601671	01N/04W-26A02S	W PL 24A		671	830	833	1,042	817	839	415	330	416	1,063	784	602	0	0	0	0	0	0	0	0
3601672	01N/04W-25B	W PL 25	✓	0	0	0	0	0	0	0	0	0	0	0	0	0	0	0	0	0	0	0	0
3601673	01N/04W-25C02S	W PL 25A		656	602	920	865	1,059	820	250	128	333	646	790	429	0	0	0	0	0	0	0	0
3601674	01N/04W-25G01S	W PL 26	✓	0	0	0	0	0	0	0	0	0	0	0	0	0	0	0	0	0	0	0	0
3601675	01N/04W-25A01S	W PL 27		913	824	809	538	456	708	805	510	211	1	0	305	0	0	0	0	0	0	0	0
3601676	01S/04W-12B05S	W PL 28	✓	125	145	174	238	264	189	0	0	0	0	0	0	0	0	0	0	0	0	0	0
3601677	01S/03W-05A02S	W PL 31	✓	0	0	0	0	0	0	0	0	0	0	0	0	0	0	0	0	0	0	0	0
3601678	01S/03W-05B04S	W PL 32	✓	0	0	0	0	0	0	0	0	0	0	0	0	0	0	0	0	0	0	0	0
3601679	01S/03W-05N05S	W PL 38	✓	0	0	0	0	0	0	0	0	0	0	0	0	0	0	0	0	0	0	0	0
3601781	01S/03W-06K01S	W PL 35/BASELINE MUT	✓	0	0	0	0	0	0	0	0	0	0	0	0	0	0	0	0	0	0	0	0

WESTERN - SAN BERNARDINO WATERMASTER
TABLE 1

VERIFIED EXTRACTIONS - FILED
SAN BERNARDINO BASIN AREA

RECRD TN NUMBER	STATE WELL NUMBER	WELL LOCAL TYPE DESIGNATION	FC	-----BASE YEARS-----										-----CALENDAR YEAR EXTRACTIONS-----				
				1959	1960	1961	1962	1963	AVG	2008	2009	2010	2011	2012	AVG			
3601884	01N/03W-31C02S	W PL 30	<input checked="" type="checkbox"/>	116	116	116	116	90	111	0	0	0	0	0	0	0	0	0
3601978	01S/03W-04N01S	W PL 40	<input type="checkbox"/>	1	3	6	6	5	4	0	0	0	0	0	0	0	0	0
3601987	01S/03W-04G02S	W PL 136 / DUNKIRK 1	<input type="checkbox"/>	16	115	200	204	332	173	0	0	0	0	0	0	0	0	0
3602034	01S/04W-01Q08S	W PL 12A	<input type="checkbox"/>				252	1,021	255	210	2	1	1	1	1	1	1	43
3602113	01N/03W-30N01S	W PL 41	<input type="checkbox"/>	273	216	254	159	241	229	0	0	0	0	0	0	0	0	0
3602174	01S/04W-02A05S	W PL 105 / MYERS	<input checked="" type="checkbox"/>	172	172	172	172	172	172	0	0	0	0	0	0	0	0	0
3602260	01S/03W-05D06S	W PL 132 / CULL#3	<input checked="" type="checkbox"/>						0	0	0	0	0	0	0	0	0	0
3602274	01N/03W-30J05S	W PL 39	<input type="checkbox"/>						0	921	1,084	937	1,086	896	896	985	985	
3602337	01N/04W-26A03S	W PL 24B	<input type="checkbox"/>						0	1,818	1,355	398	46	1,683	1,060	1,060	1,060	
3602338	01S/03W-04N03S	W PL 40A	<input type="checkbox"/>						0	0	23	1,009	441	499	394	394	394	
3602370	01N/04W-25C04S	W PL 107	<input type="checkbox"/>						0	499	1,342	1,399	926	954	1,024	1,024	1,024	
3602417	01S/03W-05D07S	W PL 132 / CULL #4	<input checked="" type="checkbox"/>						0	0	0	0	0	0	0	0	0	0
3602560	01S/03W-04G03S	W PL 136 / DUNKIRK#2	<input type="checkbox"/>						0	0	0	0	0	0	0	0	0	0
3602563	01S/04W-02Q10S	W PL 11A	<input type="checkbox"/>						0	1,546	1,911	1,629	1,288	1,028	1,480	1,480	1,480	
3602564	01S/04W-12B07S	W PL 28A	<input type="checkbox"/>						0	2,560	2,491	2,429	1,623	1,445	2,110	2,110	2,110	
3602571	01S/03W-03F02S	W PL 122	<input checked="" type="checkbox"/>						0	0	0	0	0	0	0	0	0	0
3602799	01S/02W-07F01S	W PL 125	<input type="checkbox"/>						0	1,134	965	845	1,412	1,447	1,161	1,161	1,161	
3603247	01S/03W-06P18S	W PL 141	<input type="checkbox"/>						0	1,653	808	1,056	1,535	1,668	1,344	1,344	1,344	
3603583	01S/03W-02N02S	W PLANT 143	<input type="checkbox"/>						0	617	895	981	620	966	816	816	816	
3603734	01S/03W-02P06S	W PLANT 147	<input type="checkbox"/>						0	1,768	1,539	1,738	2,004	1,717	1,753	1,753	1,753	
3603774	01S/03W-03R04S	W 146A - 7938 CHURCH	<input type="checkbox"/>						0	1,010	880	228	168	871	631	631	631	
3603904	01S/03W-05D09S	W 132-5	<input type="checkbox"/>						0	2,032	1,544	835	1,479	924	1,363	1,363	1,363	
3603926	01S/03W-06L06S	W WELL 151-HIGHLAND	<input type="checkbox"/>						0	0	1,748	1,809	2,417	2,404	1,676	1,676	1,676	
3692174	01S/04W-02A	W PL 105	<input checked="" type="checkbox"/>						0	0	0	0	0	0	0	0	0	0
TOTALS FOR EAST VALLEY WATER DISTRICT				11,544	11,992	14,081	13,523	13,257	12,879	20,587	19,421	18,120	18,408	19,538	19,215	19,215	19,215	
EASTWOOD FARMS COMMUNITY WATER USERS																		
3602130	01S/04W-01P01S	W 1	<input checked="" type="checkbox"/>	99	115	165	105	125	122	0	0	0	0	0	0	0	0	0
3602131	01S/04W-01P02S	W 2	<input checked="" type="checkbox"/>	101	115	165	105	125	122	0	0	0	0	0	0	0	0	0
TOTALS FOR EASTWOOD FARMS COMMUNITY WATER USERS				200	230	330	210	250	244	0	0	0	0	0	0	0	0	0

WESTERN - SAN BERNARDINO WATERMASTER
TABLE 1

VERIFIED EXTRACTIONS - FILED
SAN BERNARDINO BASIN AREA

RECRD TN NUMBER	STATE WELL NUMBER	WELL LOCAL TYPE DESIGNATION	FC	-----BASE YEARS-----							-----CALENDAR YEAR EXTRACTIONS-----															
				1959	1960	1961	1962	1963	AVG	2008	2009	2010	2011	2012	AVG											
ELTINGE & GRAZIADIO																										
3600766	01S/03W-29A01S	W COLTAMA	<input checked="" type="checkbox"/>	122	81	64	49	32	70	0	0	0	0	0	0	0	0	0								
TOTALS FOR ELTINGE & GRAZIADIO														122	81	64	49	32	70	0	0	0	0	0	0	0
FAIRVIEW WATER COMPANY																										
3600554	01S/03W-17R	W FAIRVVW 1	<input type="checkbox"/>	1,395	875	825	780	575	890	266	286	102	80	71	161											
TOTALS FOR FAIRVIEW WATER COMPANY														1,395	875	825	780	575	890	266	286	102	80	71	161	
FAR WELL																										
3602020	01S/02W-20K	W F A R	<input type="checkbox"/>				272	264	107	74	70	29	0	0	0	0	35									
TOTALS FOR FAR WELL																	272	264	107	74	70	29	0	0	35	
FONTANA UNION WATER COMPANY																										
3600561	01N/05W-23K01S	W FU 1	<input checked="" type="checkbox"/>	1,393	1,396	1,765	746	726	1,205	0	0	0	0	0	0	0	0									
3600562	01N/05W-22F02S	W FU 3	<input type="checkbox"/>	1,095	880	994	588	714	854	1,361	1,018	653	1,303	1,747	1,216											
3600563	01N/05W-22C02S	W FU 4	<input type="checkbox"/>	938	625	371	231	195	472	1,501	1,274	922	1,976	2,272	1,589											
3600566	01N/05W-15Q02S	W FU 8	<input checked="" type="checkbox"/>				0	0	0	0	0	0	0	0	0	0	0									
3600569	01N/05W-22A01S	W FU 13	<input type="checkbox"/>	1,783	1,876	1,539	272	47	1,103	2,512	2,161	1,360	1,585	2,586	2,041											
3600579	01N/05W-22F03S	W FU 24	<input type="checkbox"/>	0	0	0	0	0	0	624	715	950	871	1,308	894											
3600580	01N/05W-22F01S	W FU 25	<input type="checkbox"/>	1,631	1,329	942	855	881	1,128	222	0	0	0	0	44											
3600581	01N/05W-07H01S	W FU 26	<input type="checkbox"/>	319	0	0	105	0	85	385	57	855	1,001	903	640											
3600582	01N/05W-06G01S	W FU 27	<input type="checkbox"/>	652	204	58	306	42	252	419	121	170	255	1	193											
3600585	01N/05W-16K01S	W FU 32	<input type="checkbox"/>	1,051	6	0	0	0	211	852	778	1,135	1,435	1,352	1,110											
3600586	01N/05W-06K02S	W FU 33	<input type="checkbox"/>	307	355	299	418	174	311	1,482	1,559	1,028	553	1,382	1,201											
3600588	02N/06W-26L02S	W MILLER NARROWS #	<input checked="" type="checkbox"/>	0	0	0	0	0	0	0	0	0	0	0	0	0	0									
3600590	02N/06W-26L01S	W MIL NAR 2	<input checked="" type="checkbox"/>	2,185	3,145	3,006	2,421	3,162	2,784	0	0	0	0	0	0	0	0									
3600591	01N/05W-06E	W BLAND FTF	<input checked="" type="checkbox"/>	8,487	5,833	4,321	8,732	6,145	6,704	0	0	0	0	0	0	0	0									
3602727	01N/05W-15Q02S	W FU 8	<input type="checkbox"/>						0	1,165	106	1	595	1,054	584											
TOTALS FOR FONTANA UNION WATER COMPANY														19,841	15,649	13,295	14,674	12,086	15,109	10,523	7,789	7,074	9,574	12,605	9,513	
FRIEDEMANN, ERNEST C.																										
3600747	01N/03W-31P02S	W WELL 1	<input checked="" type="checkbox"/>	90	85	75	50	50	70	0	0	0	0	0	0	0	0									

WESTERN - SAN BERNARDINO WATERMASTER

TABLE 1

VERIFIED EXTRACTIIONS - FILED
SAN BERNARDINO BASIN AREA

RECRD TN NUMBER	STATE WELL NUMBER	WELL LOCAL TYPE DESIGNATION	FC	-----BASE YEARS-----											-----CALENDAR YEAR EXTRACTIIONS-----			
				1959	1960	1961	1962	1963	AVG	2008	2009	2010	2011	2012	AVG			
TOTALS FOR FRIEDEMANN, ERNEST C.				90	85	75	50	50	70	0	0	0	0	0	0	0	0	0
FRINK RANCH																		
3601131	01S/03W-30K	W 1	<input checked="" type="checkbox"/>	0	0	0	0	0	0	0	0	0	0	0	0	0	0	
TOTALS FOR FRINK RANCH				0	0	0	0	0	0	0	0	0	0	0	0	0	0	
GAY GROVE																		
3601126	01S/02W-30H	W 1	<input type="checkbox"/>	200	200	260	250	200	222	40	55	39	39	32	38	41		
TOTALS FOR GAY GROVE				200	200	260	250	200	222	40	55	39	39	32	38	41		
GENERAL AMERICAN LIFE																		
36001352	01S/03W-19N	W LANGFORD	<input type="checkbox"/>	507	493	300	285	280	373	62	62	62	62	62	62	62		
TOTALS FOR GENERAL AMERICAN LIFE				507	493	300	285	280	373	62	62	62	62	62	62	62		
GLADYSTA WELL & WATER COMPANY																		
3600182	01S/03W-20H01S	W 1	<input checked="" type="checkbox"/>	527	486				203	0	0	0	0	0	0	0		
3600182-	01S/03W-20H02S	W	<input type="checkbox"/>	609	517	507	507	507	327	51	65	88	99	143	89			
TOTALS FOR GLADYSTA WELL & WATER COMPANY				527	486	609	517	507	529	51	65	88	99	143	89			
GOLDEN BEAR FOREST PRODUCTS																		
3602127	01S/03W-15A01S	W 1	<input checked="" type="checkbox"/>	30	30	33	33	33	32	0	0	0	0	0	0	0		
TOTALS FOR GOLDEN BEAR FOREST PRODUCTS				30	30	33	33	33	32	0	0	0	0	0	0			
GRANT WATER COMPANY																		
3600075	01S/03W-28C01S	W GRANT	<input checked="" type="checkbox"/>	429	424	483	436	363	427	0	0	0	0	0	0	0		
TOTALS FOR GRANT WATER COMPANY				429	424	483	436	363	427	0	0	0	0	0	0			
GREENSPOT MUTUAL WELL COMPANY																		
3600266	01S/02W-16C01S	W GRNSPTMU	<input type="checkbox"/>	142	149	121	105	76	119	215	311	141	138	188	199			
TOTALS FOR GREENSPOT MUTUAL WELL COMPANY				142	149	121	105	76	119	215	311	141	138	188	199			
GREENSPOT VILLAGE & MARKET PLACE LLC																		
3600026	01S/03W-04J01S	W PL 102	<input type="checkbox"/>	1,711	1,467	2,031	1,017	760	1,397	0	0	0	0	0	0			

WESTERN - SAN BERNARDINO WATERMASTER

TABLE 1

VERIFIED EXTRACTIONS - FILED
SAN BERNARDINO BASIN AREA

RECRD TN NUMBER	STATE WELL NUMBER	WELL LOCAL TYPE DESIGNATION	FC	-----BASE YEARS-----							-----CALENDAR YEAR EXTRACTIONS-----					
				1959	1960	1961	1962	1963	AVG	2008	2009	2010	2011	2012	AVG	
TOTALS FOR GREENSPOT VILLAGE & MARKET PLACE LLC				1,711	1,467	2,031	1,017	760	1,397	0	0	0	0	0	0	0
GUERTH, WILLIAM H.																
3600856	01N/03W-27M	D CITY CREEK	<input checked="" type="checkbox"/>	1,585	695	922	1,230	860	1,058	0	0	0	0	0	0	
TOTALS FOR GUERTH, WILLIAM H.				1,585	695	922	1,230	860	1,058	0	0	0	0	0	0	
HAPPE MUTUAL WELL COMPANY																
3600238	01S/02W-29M01S	W 1	<input type="checkbox"/>	526	592	649	358	500	525	24	97	71	79	63	67	
TOTALS FOR HAPPE MUTUAL WELL COMPANY				526	592	649	358	500	525	24	97	71	79	63	67	
HEAD, JOE T.																
3600226	01S/02W-21L01S	W 1	<input checked="" type="checkbox"/>	0	0	0	0	0	0	0	0	0	0	0	0	
TOTALS FOR HEAD, JOE T.				0	0	0	0	0	0	0	0	0	0	0	0	
HIGHLAND ACRES RANCH																
3600323	01S/02W-06M	W ELEC 1	<input checked="" type="checkbox"/>	250	160	350	400	400	312	0	0	0	0	0	0	
TOTALS FOR HIGHLAND ACRES RANCH				250	160	350	400	400	312	0	0	0	0	0	0	
HIGHLAND WELL COMPANY																
3600184	01N/03W-28N01S	W HWC 1	<input checked="" type="checkbox"/>	278	263	265	232	184	244	0	0	0	0	0	0	
TOTALS FOR HIGHLAND WELL COMPANY				278	263	265	232	184	244	0	0	0	0	0	0	
HINCKLEY, HORACE P.																
3600240	01S/02W-30B	W SOUTH WELL	<input checked="" type="checkbox"/>	401	325	337	230	176	294	0	0	0	0	0	0	
3601645	01S/02W-30B	W 1	<input checked="" type="checkbox"/>	417	310	275	232	215	290	0	0	0	0	0	0	
TOTALS FOR HINCKLEY, HORACE P.				818	635	612	462	391	584	0	0	0	0	0	0	
HOLIDAY TRUCKING																
3603262	01N/04W-31M03S	W SB #1	<input type="checkbox"/>						0	59	61	59	60	60	60	
TOTALS FOR HOLIDAY TRUCKING									0	59	61	59	60	60	60	
HOLMES ICE & COLD STORAGE																
3600644	01S/04W-09B03S	W 2	<input checked="" type="checkbox"/>	591	405	410	345	344	419	0	0	0	0	0	0	
3600645	01S/04W-09B01S	W	<input checked="" type="checkbox"/>	0	0	0	0	0	0	0	0	0	0	0	0	

WESTERN - SAN BERNARDINO WATERMASTER

TABLE 1

VERIFIED EXTRACTIONS - FILED
SAN BERNARDINO BASIN AREA

RECRD TN NUMBER	STATE WELL NUMBER	WELL LOCAL TYPE DESIGNATION	FC	-----BASE YEARS-----							-----CALENDAR YEAR EXTRACTIONS-----					
				1959	1960	1961	1962	1963	AVG	2008	2009	2010	2011	2012	AVG	
TOTALS FOR HOLMES ICE & COLD STORAGE				591	405	410	345	344	419	0	0	0	0	0	0	0
HOOVER WELL																
3601649	01S/03W-28M	W HOOVER	<input checked="" type="checkbox"/>	100	100	100			60	0	0	0	0	0	0	
TOTALS FOR HOOVER WELL				100	100	100			60	0	0	0	0	0	0	
INLAND VALLEY DEVELOPMENT AGENCY																
3603646	01S/03W-07D	W NORTON #2A	<input type="checkbox"/>						0	0	0	0	0	0	0	
3603647	01S/04W-12C01S	W NORTON #3	<input type="checkbox"/>						0	0	0	0	0	0	0	
3603648	01S/04W-12F	W NORTON #5	<input type="checkbox"/>						0	0	0	0	0	0	0	
3603650	01S/03W-18C	W NORTON GOLF COU	<input type="checkbox"/>						0	75	0	0	0	0	15	
TOTALS FOR INLAND VALLEY DEVELOPMENT AGENCY									0	75	0	0	0	0	15	
IOWA STREET WELL																
3601932	01S/03W-29B01S	W	<input checked="" type="checkbox"/>	62	62	21	10	7	32	0	0	0	0	0	0	
TOTALS FOR IOWA STREET WELL				62	62	21	10	7	32	0	0	0	0	0	0	
J. G. GOLFING ENTERPRISES																
3602499	01S/04W-22A01S	W PAYNE H 25	<input type="checkbox"/>						0	206	251	304	196	192	230	
3602846	01S/04W-22A01S	W THORN 10 & 11	<input type="checkbox"/>						0	469	319	282	394	439	381	
TOTALS FOR J. G. GOLFING ENTERPRISES									0	675	570	586	590	631	610	
JACINTO FARMING, LARRY																
3603967	01S/02W-20G	W SAPPHIRE	<input type="checkbox"/>						0	-	-	-	-	1	0	
TOTALS FOR JACINTO FARMING, LARRY									0	-	-	-	-	1	0	
JEWEL WATER COMPANY																
3600091	01S/03W-20R	W 1	<input checked="" type="checkbox"/>	504	408	356	293	258	364	0	0	0	0	0	0	
TOTALS FOR JEWEL WATER COMPANY				504	408	356	293	258	364	0	0	0	0	0	0	
JUDSON MUTUAL WATER COMPANY																
3601647	01S/03W-23A03S	W 1	<input checked="" type="checkbox"/>	403	356	348	367	363	367	0	0	0	0	0	0	
TOTALS FOR JUDSON MUTUAL WATER COMPANY				403	356	348	367	363	367	0	0	0	0	0	0	

WESTERN - SAN BERNARDINO WATERMASTER

TABLE 1

VERIFIED EXTRACTIONS - FILED
SAN BERNARDINO BASIN AREA

RECRD TN NUMBER	STATE WELL NUMBER	WELL LOCAL TYPE DESIGNATION	FC	-----BASE YEARS-----							AVG	-----CALENDAR YEAR EXTRACTIONS-----			
				1959	1960	1961	1962	1963	1963	1963		2008	2009	2010	2011
K INV/ EVCA/ Y UN WELL															
3601172	01S/03W-20C	W	<input checked="" type="checkbox"/>	380	350	415	362	358	358	373	0	0	0	0	0
TOTALS FOR K INV/ EVCA/ Y UN WELL				380	350	415	362	358	358	373	0	0	0	0	0
KANSAS STREET MUTUAL WATER COMPANY															
3601092	01S/03W-28D01S	W KANSAS	<input type="checkbox"/>	376	327	378	328	353	352	352	0	0	0	0	0
TOTALS FOR KANSAS STREET MUTUAL WATER COMPANY				376	327	378	328	353	352	352	0	0	0	0	0
KING STREET MUTUAL WELL COMPANY															
3600530	01S/02W-30G01S	W 1	<input checked="" type="checkbox"/>	408	371	358	281		284	0	0	0	0	0	
3600530-	01S/02W-30G02S	W 2	<input type="checkbox"/>					372	74	5	5	5	5	5	
TOTALS FOR KING STREET MUTUAL WELL COMPANY				408	371	358	281	372	358	5	5	5	5	5	
KOCH, GEORGE J.															
3601451	01S/02W-32G01S	W 1	<input checked="" type="checkbox"/>				0	0	0	0	0	0	0	0	
TOTALS FOR KOCH, GEORGE J.							0	0	0	0	0	0	0	0	
L P R ICE COMPANY WELL															
3602525	01S/03W-13C	W LPR ICE CO	<input checked="" type="checkbox"/>						0	0	0	0	0	0	
TOTALS FOR L P R ICE COMPANY WELL									0	0	0	0	0	0	
LA BONTE, JIM															
3600865	01N/04W-24H	W MULTOWN2	<input type="checkbox"/>	5	5	5	5	5	5	5	4	4	4	4	
TOTALS FOR LA BONTE, JIM				5	5	5	5	5	5	5	4	4	4	4	
LA ROSSE, CHARLES H															
3600708	01S/03W-29B	W GOODWIN	<input checked="" type="checkbox"/>	38	21	35	18	14	25	0	0	0	0	0	
TOTALS FOR LA ROSSE, CHARLES H				38	21	35	18	14	25	0	0	0	0	0	
LAKESIDE AVENUE MUTUAL WELL COMPANY															
3602119	01S/03W-33C01S	W REDLANDS	<input checked="" type="checkbox"/>	79	48	58	51	20	51	0	0	0	0	0	
TOTALS FOR LAKESIDE AVENUE MUTUAL WELL COMPANY				79	48	58	51	20	51	0	0	0	0	0	

WESTERN - SAN BERNARDINO WATERMASTER
TABLE 1

VERIFIED EXTRACTIIONS - FILED
SAN BERNARDINO BASIN AREA

RECRD TN NUMBER	STATE WELL NUMBER	WELL LOCAL TYPE DESIGNATION	FC	1959	1960	1961	1962	1963	AVG	2008	2009	2010	2011	2012	AVG	
				-----BASE YEARS-----					-----CALENDAR YEAR EXTRACTIIONS-----							
LANDMARK LAND COMPANY																
3600187	01S/02W-09Q01S	W 1, SOLANO WELL #1	<input checked="" type="checkbox"/>	212	143	147	88	43	127	0	0	0	0	0	0	
TOTALS FOR LANDMARK LAND COMPANY				212	143	147	88	43	127	0	0	0	0	0	0	0
LANGSTON-NEWBY DEVELOPMENT COMPANY																
3600218	01N/04W-24A	W 1	<input checked="" type="checkbox"/>	50	50	50	50	50	50	0	0	0	0	0	0	
TOTALS FOR LANGSTON-NEWBY DEVELOPMENT COMPANY				50	50	50	50	50	50	0	0	0	0	0	0	0
LOMA LINDA UNIVERSITY																
3601910	01S/03W-30L	W PUFFER	<input checked="" type="checkbox"/>	112	129	129	97	87	111	0	0	0	0	0	0	
3602008	01S/04W-26A	W 1	<input checked="" type="checkbox"/>	146	98	177	203	209	167	0	0	0	0	0	0	
3602009	01S/04W-25G01S	W 3	<input checked="" type="checkbox"/>	195	364	407	304	78	270	0	0	0	0	0	0	
3602012	01S/04W-25C01S	W 6	<input checked="" type="checkbox"/>	323	369	376	463	347	376	0	0	0	0	0	0	
3602013	01S/04W-24N	W 7	<input checked="" type="checkbox"/>	149	70	27	13	69	66	0	0	0	0	0	0	
3602014	01S/04W-26J01S	W 8	<input checked="" type="checkbox"/>	86	86	86	86	111	91	0	0	0	0	0	0	
3602017	01S/04W-25E01S	W 2	<input checked="" type="checkbox"/>					0	0	0	0	0	0	0	0	
3602249	01S/04W-25D05S	W ANDERSON	<input checked="" type="checkbox"/>					0	0	0	0	0	0	0	0	
3602781	01S/04W-25D06S	W ANDERSON II	<input type="checkbox"/>					0	0	92	89	138	67	64	90	
3602855	01S/04W-25D07S	W ANDERSON III	<input type="checkbox"/>					0	0	1,308	1,270	1,155	1,276	1,353	1,272	
TOTALS FOR LOMA LINDA UNIVERSITY				1,011	1,116	1,202	1,166	901	1,079	1,400	1,359	1,293	1,343	1,417	1,362	
LOMA LINDA, CITY OF																
3601384	01S/04W-25C	W 1	<input checked="" type="checkbox"/>	0	0	0	20	73	19	0	0	0	0	0	0	
3601388	01S/04W-25C	W COURT ST	<input checked="" type="checkbox"/>	111	114	147	140	98	122	0	0	0	0	0	0	
3601989	01S/04W-24R01S	W GOLCONDA	<input checked="" type="checkbox"/>	44	40	37	32	42	39	0	0	0	0	0	0	
3602010	01S/04W-25H02S	W VAN LEUVEN	<input checked="" type="checkbox"/>	123	160	100	105	131	124	0	0	0	0	0	0	
3602011	01S/04W-25B02S	W DART	<input checked="" type="checkbox"/>	61	150	166	232	219	166	0	0	0	0	0	0	
3602015	01S/04W-25B	W NIES	<input checked="" type="checkbox"/>	1,077	772	760	615	627	770	0	0	0	0	0	0	
3602016	01S/04W-25G	W ROBINSON	<input checked="" type="checkbox"/>	57	161	228	157	59	132	0	0	0	0	0	0	
3602057	01S/04W-25C	W MITTLEID	<input checked="" type="checkbox"/>	335	420	524	400	16	339	0	0	0	0	0	0	
3602058	01S/04W-25F	W CROOKS	<input checked="" type="checkbox"/>	19	23	29	28	25	25	0	0	0	0	0	0	
3602596	01S/04W-24R07S	W NEW GOLCONDA	<input checked="" type="checkbox"/>						0	0	0	0	0	0	0	
3602759	01S/04W-24A01S	W MT VIEW 1	<input checked="" type="checkbox"/>						0	0	0	0	0	0	0	

WESTERN - SAN BERNARDINO WATERMASTER
TABLE 1

VERIFIED EXTRACTIONS - FILED
SAN BERNARDINO BASIN AREA

RECRD TN NUMBER	STATE WELL NUMBER	WELL LOCAL TYPE DESIGNATION	FC	-----BASE YEARS-----							-----CALENDAR YEAR EXTRACTIONS-----											
				1959	1960	1961	1962	1963	AVG	2008	2009	2010	2011	2012	AVG							
3602760	01S/04W-24B01S	W MT VIEW 2	<input checked="" type="checkbox"/>						0	0	0	0	0	0	0	0	0	0	0	0	0	0
3603057	01S/04W-24C01S	W RICHARDSON #1	<input type="checkbox"/>						0	422	323	56	0	0	0	160						
3603058	01S/04W-24C02S	W RICHARDSON #2	<input checked="" type="checkbox"/>						0	0	0	0	0	0	0	0						
3603523	01S/04W-24P04S	W RICHARDSON #3	<input type="checkbox"/>						0	1,503	1,546	1,046	978	951	1,205							
3603719	01S/04W-24A05S	W MTN. VIEW #3	<input type="checkbox"/>						0	1,732	2,265	2,200	442	795	1,487							
3603720	01S/04W-24F11S	W RICHARDSON #4	<input type="checkbox"/>						0	464	446	51	0	0	192							
3603721	01S/04W-24R08S	W MTN. VIEW #4	<input type="checkbox"/>						0	0	0	0	0	0	0							
3603776	01S/04W-24B03S	W MTN. VIEW #5	<input type="checkbox"/>						0	592	44	138	0	0	155							
3603927	01S/04W-24L07S	W RICHARDSON #6	<input type="checkbox"/>						0	-	0	1,372	1,989	1,188	910							
3603955	01S/04W-24B05S	W RICHARDSON #5	<input type="checkbox"/>						0	-	-	-	1,252	1,305	511							
3603956	01S/04W-24B04S	W MTN. VIEW #6	<input type="checkbox"/>						0	-	-	-	740	1,537	455							
TOTALS FOR LOMA LINDA, CITY OF				1,827	1,840	1,991	1,729	1,290	1,735	4,713	4,624	4,863	5,401	5,776	5,075							
LULY, LUCIAN L																						
3601376	01N/04W-14C	D WATERMAN	<input checked="" type="checkbox"/>						0	0	0	0	0	0	0							
3601377	01N/04W-14C	D WATERMAN	<input checked="" type="checkbox"/>						0	0	0	0	0	0	0							
3601378	01N/04W-14C	D WATERMAN	<input checked="" type="checkbox"/>						0	0	0	0	0	0	0							
TOTALS FOR LULY, LUCIAN L				0	0	0	0	0	0	0	0	0	0	0	0							
MAJESTIC MANAGEMENT																						
3601102	01S/03W-21E	W 2 / MASCART	<input checked="" type="checkbox"/>	395	302	468	381	367	383	0	0	0	0	0	0							
TOTALS FOR MAJESTIC MANAGEMENT				395	302	468	381	367	383	0	0	0	0	0	0	0						
MARIGOLD FARMS COMPANY																						
3600757	01S/03W-19L	W 2, MISSION #2	<input type="checkbox"/>	374	272	367	433	322	354	250	250	250	289	225	253							
3601749	01S/03W-19B01S	W JAP	<input checked="" type="checkbox"/>	91	364	180	600	64	260	0	0	0	0	0	0							
TOTALS FOR MARIGOLD FARMS COMPANY				465	636	547	1,033	386	613	250	250	250	289	225	253							
MAYBELL, N O																						
3600291	01S/04W-12N	W	<input checked="" type="checkbox"/>	26	26	12	12	12	18	0	0	0	0	0	0							
TOTALS FOR MAYBELL, N O				26	26	12	12	12	18	0	0	0	0	0	0	0						

WESTERN - SAN BERNARDINO WATERMASTER
TABLE 1

VERIFIED EXTRACTIIONS - FILED
SAN BERNARDINO BASIN AREA

RECRD TN NUMBER	STATE WELL NUMBER	WELL LOCAL TYPE DESIGNATION	FC	-----BASE YEARS-----							-----CALENDAR YEAR EXTRACTIIONS-----				
				1959	1960	1961	1962	1963	AVG	2008	2009	2010	2011	2012	AVG
MCCALLA, ROBERT															
3601839	01S/03W-10D01S	W 1	<input checked="" type="checkbox"/>	5	13	37	21	22	20	0	0	0	0	0	0
TOTALS FOR MCCALLA, ROBERT														0	
MEADOWBROOK DAIRY															
3600030	01S/04W-23D	W IRRIG 2	<input checked="" type="checkbox"/>	443	343	295	288	421	358	0	0	0	0	0	0
3600037	01S/04W-23D	W DOMESTC 1	<input checked="" type="checkbox"/>	49	45	45	43	41	45	0	0	0	0	0	0
TOTALS FOR MEADOWBROOK DAIRY														0	
MENTONE CITRUS GROWERS															
3600139	01S/02W-18R01S	W 1-PRH RANCH	<input type="checkbox"/>	714	873	637	409	306	588	148	153	117	114	71	121
3602280	01S/02W-18Q	W #2	<input type="checkbox"/>						0	518	587	531	802	871	662
TOTALS FOR MENTONE CITRUS GROWERS														782	
MEYER, CHARLES R															
3600760	01N/05W-01R	W 1	<input checked="" type="checkbox"/>	42	42	55	51	53	49	0	0	0	0	0	0
TOTALS FOR MEYER, CHARLES R														0	
MILLER MUTUAL WELL COMPANY															
3600630	01N/03W-32D	W	<input checked="" type="checkbox"/>	20	8	0	0	0	6	0	0	0	0	0	0
3600630-	01N/03W-32D	W	<input type="checkbox"/>			41	58	53	30	5	5	5	5	5	5
TOTALS FOR MILLER MUTUAL WELL COMPANY														5	
MONTE LLC															
3600493	01S/03W-29K	W 2 NEW WELL	<input checked="" type="checkbox"/>	205	225	250	220	247	229	0	0	0	0	0	0
3600494	01S/03W-29K	W 1 OLD WELL	<input type="checkbox"/>	283	309	322	305	268	297	65	59	53	63	65	61
TOTALS FOR MONTE LLC														61	
MONTECITO MEMORIAL PARK															
3600119	01S/04W-26F01S	W 1	<input type="checkbox"/>	104	109	110	77	71	94	270	270	223	130	155	210
3603949	01S/04W-26F	W MONTECITO #2	<input type="checkbox"/>						0	-	0	223	138	177	108
TOTALS FOR MONTECITO MEMORIAL PARK														317	

WESTERN - SAN BERNARDINO WATERMASTER
TABLE 1

VERIFIED EXTRACTIONS - FILED
SAN BERNARDINO BASIN AREA

RECRD TN NUMBER	STATE WELL NUMBER	WELL LOCAL TYPE DESIGNATION	FC	-----BASE YEARS-----							-----CALENDAR YEAR EXTRACTIONS-----				
				1959	1960	1961	1962	1963	AVG	2008	2009	2010	2011	2012	AVG
MOUNT VERNON WATER CO.															
3600319	01N/04W-31A01S	W 1	<input type="checkbox"/>	1,020	748	1,030	624	508	786	927	1,132	167	685	799	742
TOTALS FOR MOUNT VERNON WATER CO.														742	
MOUNTAIN VIEW POWER CO.															
3600651	01S/03W-28L	W	<input checked="" type="checkbox"/>	58	35	64	47	49	51	0	0	0	0	0	0
3601012	01S/04W-08R	W STM PL 1	<input checked="" type="checkbox"/>	2	2	2	2	2	2	0	0	0	0	0	0
3601013	01S/04W-08R	W STM PL 2	<input checked="" type="checkbox"/>	0	0	0	0	0	0	0	0	0	0	0	0
3601014	01S/03W-18N03S	W MTN. VIEW STPM 66	<input type="checkbox"/>	266	182	312	307	110	235	389	103	260	256	403	282
3601015	01S/03W-18N02S	W MT VIEW STMP2 #67	<input type="checkbox"/>	266	239	362	368	583	364	89	257	131	64	10	110
3601016	01S/04W-22G01S	W THORN 1	<input checked="" type="checkbox"/>	818	761	685	2	0	453	0	0	0	0	0	0
3603795	01S/03W-18N06S	W MVL MID-AQUIFER #1	<input type="checkbox"/>						0	1,031	972	1,172	1,225	1,864	1,253
3603796	01S/03W-18M01S	W MVL MID-AQUIFER #2	<input type="checkbox"/>						0	1,073	935	838	449	356	730
3604011	01S/03W-18N04S	W AUX 2A	<input checked="" type="checkbox"/>						0	0	0	0	0	0	0
TOTALS FOR MOUNTAIN VIEW POWER CO.														2,375	
MT. VIEW CEMETERY															
3600742	01N/04W-26N	W 1	<input checked="" type="checkbox"/>	17	15	12	13	4	12	0	0	0	0	0	0
3600742-	01N/04W-26N	W MT VIEW #2 (#3 WES	<input type="checkbox"/>						0	104	109	123	151	114	120
3600743	01N/04W-26M	W MT VIEW #1 (#2 SHED	<input type="checkbox"/>	211	170	133	237	137	178	141	126	119	111	161	132
TOTALS FOR MT. VIEW CEMETERY														252	
MUSCOY MUTUAL WATER COMPANY NO. 1															
3601497	01N/05W-23H01S	W MUSCOY 1	<input type="checkbox"/>	648	624	676	621	562	626	460	1,203	379	318	375	547
3601498	01N/05W-24D01S	W LACY #5	<input type="checkbox"/>	0					0	375	317	450	308	308	352
3601499	01N/05W-23A01S	W MUSCOY 2	<input type="checkbox"/>	648	623	676	621	561	626	463	80	314	413	393	333
3601500	01N/05W-23A02S	W MUSCOY 3	<input type="checkbox"/>	647	623	676	621	561	626	463	87	322	416	453	348
3602345	01N/05W-24E01S	W MUSCOY 4	<input type="checkbox"/>						0	203	40	161	236	222	172
TOTALS FOR MUSCOY MUTUAL WATER COMPANY NO. 1														1,752	
NATIONAL ORANGE SHOW															
3601924	01S/04W-15D	W	<input type="checkbox"/>	135	135	135	135	135	135	20	50	1	50	62	37

WESTERN - SAN BERNARDINO WATERMASTER

TABLE 1

VERIFIED EXTRACTIIONS - FILED
SAN BERNARDINO BASIN AREA

RECRD TN NUMBER	STATE WELL NUMBER	WELL LOCAL TYPE DESIGNATION	FC	-----BASE YEARS-----							-----CALENDAR YEAR EXTRACTIIONS-----						
				1959	1960	1961	1962	1963	AVG	2008	2009	2010	2011	2012	AVG		
TOTALS FOR NATIONAL ORANGE SHOW				135	135	135	135	135	135	135	20	50	1	50	62	37	
NEALEY MUTUAL WATER COMPANY																	
3601381	01N/05W-07C	D	<input checked="" type="checkbox"/>	0	0	0	0	0	0	0	0	0	0	0	0	0	
TOTALS FOR NEALEY MUTUAL WATER COMPANY				0	0	0	0	0	0	0	0	0	0	0	0	0	
NEW ENGLAND WATER COMPANY																	
3602320-	01S/03W-16L	W	<input type="checkbox"/>							0	229	250	200	195	360	247	
TOTALS FOR NEW ENGLAND WATER COMPANY									0	229	250	200	195	360	247		
NICKERSON WATER COMPANY																	
3600123	01S/03W-20R01S	W 1	<input checked="" type="checkbox"/>	212	220	348	297	250	265	265	0	0	0	0	0	0	
TOTALS FOR NICKERSON WATER COMPANY				212	220	348	297	250	265	265	0	0	0	0	0	0	0
NICKERSON WATER COMPANY NO 2																	
3600124	01S/03W-21M01S	W 2	<input checked="" type="checkbox"/>	466	331	490	424	290	400	400	0	0	0	0	0	0	
TOTALS FOR NICKERSON WATER COMPANY NO 2				466	331	490	424	290	400	400	0	0	0	0	0	0	0
NORTH FORK WATER COMPANY																	
3600678	01S/02W-08C01S	W 1	<input checked="" type="checkbox"/>	310	291	285	266	277	286	286	0	0	0	0	0	0	
3600679	01S/02W-08C02S	W N FORK #2	<input checked="" type="checkbox"/>	163	142	131	136	119	138	138	0	0	0	0	0	0	
3601644	01S/03W-01A	W PLUNGE CK	<input checked="" type="checkbox"/>	3	10	0	62	0	15	15	0	0	0	0	0	0	
TOTALS FOR NORTH FORK WATER COMPANY				476	443	416	464	396	439	439	0	0	0	0	0	0	0
NORTHBRAE WATER COMPANY																	
3600296	01S/03W-15R01S	W 1	<input checked="" type="checkbox"/>	394	530	608	395	466	479	479	0	0	0	0	0	0	
TOTALS FOR NORTHBRAE WATER COMPANY				394	530	608	395	466	479	479	0	0	0	0	0	0	0
NORTHSIDE WATER COMPANY																	
3600933	01S/03W-23F	W 1	<input checked="" type="checkbox"/>	398	402	491	385	333	402	402	0	0	0	0	0	0	
TOTALS FOR NORTHSIDE WATER COMPANY				398	402	491	385	333	402	402	0	0	0	0	0	0	0
PAYNE, LARRY																	
3603698	02N/05W-27L	W OWNERS #1	<input type="checkbox"/>						0	40	1	1	1	1	9		

WESTERN - SAN BERNARDINO WATERMASTER
TABLE 1

VERIFIED EXTRACTIONS - FILED
SAN BERNARDINO BASIN AREA

RECRD TN NUMBER	STATE WELL NUMBER	WELL LOCAL TYPE DESIGNATION	FC	-----BASE YEARS-----							AVG	-----CALENDAR YEAR EXTRACTIONS-----						
				1959	1960	1961	1962	1963	1963	2008		2009	2010	2011	2012	AVG		
3603699	02N/05W-27L02S	W OWNERS #2	<input type="checkbox"/>							0	0	0	1	1	1	1	1	
3603700	02N/05W-27L03S	W OWNERS #3	<input type="checkbox"/>							0	0	0	0	0	0	0	0	
TOTALS FOR PAYNE, LARRY										0	40	2	2	2	2	2	10	
PENN WELL COMPANY																		
3601099	01S/03W-22F	W 1	<input checked="" type="checkbox"/>	0	0	0	0	0	0	0	0	0	0	0	0	0	0	
3601405	01S/03W-22F	W 2	<input checked="" type="checkbox"/>	539	447	504	550	440	440	496	0	0	0	0	0	0	0	
TOTALS FOR PENN WELL COMPANY				539	447	504	550	440	440	496	0	0	0	0	0	0	0	0
PHARAOHS LOST KINDGOM																		
3602549	01S/03W-19J07S	W CALIF ST	<input type="checkbox"/>							0	50	50	50	50	33	30	43	
TOTALS FOR PHARAOHS LOST KINDGOM										0	50	50	50	50	33	30	43	
PHARAOH-POWERLL WATER CO																		
3600415	01S/03W-29J01S	W	<input type="checkbox"/>	326	350	365	371	322	322	347	199	241	182	169	218	202	202	
TOTALS FOR PHARAOH-POWERLL WATER CO				326	350	365	371	322	322	347	199	241	182	169	218	218	202	
PIONEER MUTUAL WATER CO																		
3600642	01S/03W-14P01S	W SBDNO 1	<input type="checkbox"/>	314	222	288	316	275	275	283	30	20	21	22	24	23	23	
TOTALS FOR PIONEER MUTUAL WATER CO				314	222	288	316	275	275	283	30	20	21	22	24	24	23	
RAMIREZ, J. J.																		
3600484	01S/03W-16F	W BUCKEYE2	<input type="checkbox"/>	246	220	352	224	259	260	260	0	0	0	0	0	0	0	
3600525	01S/03W-17H01S	W ALABAMA	<input checked="" type="checkbox"/>	214	263	231	369	336	283	283	0	0	0	0	0	0	0	
3600527	01S/03W-16A	W MIDAS	<input type="checkbox"/>	133	133	133	133	133	133	133	125	119	98	96	95	107	107	
3601046	01S/03W-21A	W STOWE	<input checked="" type="checkbox"/>						0	0	0	0	0	0	0	0	0	
3601046-	01S/03W-21A	W STOWE	<input checked="" type="checkbox"/>	630	598	622	560	667	615	615	0	0	0	0	0	0	0	
3601649-	01S/03W-28M	W HOOVER	<input type="checkbox"/>				25	85	22	22	0	0	0	0	0	0	0	
3601728	01S/03W-30K	W FRINK'S #1	<input type="checkbox"/>	61	61	65	62	64	63	63	0	0	0	0	0	0	0	
TOTALS FOR RAMIREZ, J. J.				1,284	1,275	1,403	1,373	1,544	1,376	1,376	125	119	98	96	95	107	107	
RANCHO CITRUS AMIGOS																		
3601753	01S/03W-29D	W PARK AVE 1	<input checked="" type="checkbox"/>	80	80	80	80	80	80	80	0	0	0	0	0	0	0	

WESTERN - SAN BERNARDINO WATERMASTER
TABLE 1

VERIFIED EXTRACTIIONS - FILED
SAN BERNARDINO BASIN AREA

RECRD TN NUMBER	STATE WELL TYPE DESIGNATION	WELL LOCAL TYPE DESIGNATION	FC	-----BASE YEARS-----							-----CALENDAR YEAR EXTRACTIIONS-----																
				1959	1960	1961	1962	1963	AVG	2008	2009	2010	2011	2012	AVG												
TOTALS FOR RANCHO CITRUS AMIGOS														80	80	80	80	80	80	80	0	0	0	0	0	0	0
RAUGHT MUTUAL WELL COMPANY																											
3602193	01S/03W-14R01S	W RAUGHT	<input type="checkbox"/>	504	550	552	506	520	526	526	204	248	215	239	255	232											
TOTALS FOR RAUGHT MUTUAL WELL COMPANY														504	550	552	506	520	526	204	248	215	239	255	232		
REDLANDS COUNTRY CLUB																											
3600049	01S/03W-25N01S	W MORRISON	<input checked="" type="checkbox"/>	174	96				54		0	0	0	0	0	0											
3600049-	01S/03W-25N02S	W MORRISON/HOBBS	<input checked="" type="checkbox"/>			696	692	532	384		0	0	0	0	0	0											
TOTALS FOR REDLANDS COUNTRY CLUB														174	96	696	692	532	438	0	0	0	0	0	0		
REDLANDS FARMING																											
3600523	01S/03W-32G03S	W HNTSCHKE	<input checked="" type="checkbox"/>	298	222	101	109	103	167		0	0	0	0	0	0											
3600526	01S/03W-21G01S	W LUGONIA	<input checked="" type="checkbox"/>	475	425	343	326	360	386		0	0	0	0	0	0											
TOTALS FOR REDLANDS FARMING														773	647	444	435	463	552	0	0	0	0	0	0		
REDLANDS TRAP/SKEET																											
3600628	01S/03W-15G	W	<input checked="" type="checkbox"/>	145	235	235	2	2	124		0	0	0	0	0	0											
TOTALS FOR REDLANDS TRAP/SKEET														145	235	235	2	2	124	0	0	0	0	0	0		
REDLANDS UNIFIED SCHOOL DISTRICT																											
3601641	01S/02W-30C01S	W OPAL ST	<input type="checkbox"/>	470	462	484	410	470	459		140	201	98	59	109	121											
TOTALS FOR REDLANDS UNIFIED SCHOOL DISTRICT														470	462	484	410	470	459	140	201	98	59	109	121		
REDLANDS, CITY OF																											
3600005	01S/03W-35H08S	W LUETCKE	<input checked="" type="checkbox"/>	741	493	543	448	391	523		0	0	0	0	0	0											
3600006	01S/02W-19G01S	W E. LUGONIA #5	<input type="checkbox"/>	261	131	94	12	0	100		0	0	0	0	0	0											
3600019	01S/03W-23A05S	W GR REES 1	<input type="checkbox"/>	531	288	342	320	461	388		0	258	1,114	1,759	1,633	953											
3600038	01S/02W-17N	D DRY CREEK DIVERSI	<input checked="" type="checkbox"/>						0		0	0	0	0	0	0											
3600053	01S/03W-31A02S	W 1, BRYN MAWR	<input type="checkbox"/>	585	470	583	296	249	437		0	0	0	0	0	0											
3600054	01S/03W-31A03S	W 2, BRYN MAWR MUT	<input checked="" type="checkbox"/>	306	330	375	295	0	261		0	0	0	0	0	0											
3600055	01S/03W-31A06S	W 3, BRYN MAWR MUTU	<input checked="" type="checkbox"/>	306	330	375	0	249	252		0	0	0	0	0	0											
3600085	01S/03W-28J01S	W NY ST 1	<input checked="" type="checkbox"/>	190	186	180	180	180	183		0	0	0	0	0	0											

WESTERN - SAN BERNARDINO WATERMASTER
TABLE 1

VERIFIED EXTRACTIONS - FILED
SAN BERNARDINO BASIN AREA

RECRD TN NUMBER	STATE WELL NUMBER	WELL LOCAL TYPE DESIGNATION	FC	-----BASE YEARS-----											-----CALENDAR YEAR EXTRACTIONS-----				
				1959	1960	1961	1962	1963	AVG	2008	2009	2010	2011	2012	AVG				
3600510	01S/03W-21K01S	W LUGO #1	<input checked="" type="checkbox"/>	414	346	324	300	239	325	0	0	0	0	0	0	0	0	0	0
3600748	01S/03W-24A01S	W MENTONE ACRES #1-	<input type="checkbox"/>	455	495	505	475	121	410	0	0	973	91	73	75	242			
3600749	01S/03W-13P01S	W MENTONE ACRES #2-	<input type="checkbox"/>	885	960	975	940	917	935	0	0	0	155	1,743	1,357	814			
3600756	01S/03W-19L01S	W MISSION #1	<input type="checkbox"/>	715	510	675	660	560	624	0	0	0	0	0	0	0			
3600918	02S/03W-01D01S	W 1, REDLANDS HEIGH	<input type="checkbox"/>	604	567	554	459	480	533	364	373	321	381	401	368				
3601281	01S/02W-21M01S	W MAGUET #1	<input type="checkbox"/>	133	123	195	75	61	117	0	0	0	0	0	0				
3601282	01S/01W-08H01S	W MILL CREEK #1	<input type="checkbox"/>	1,296	916	839	955	1,132	1,028	0	0	0	0	0	0				
3601283	01S/02W-22C02S	W EAST LUGONIA #2	<input type="checkbox"/>	225	186	114	41	7	115	0	0	0	0	0	0				
3601284	01S/02W-21E01S	W MAGUET #2	<input type="checkbox"/>	162	83	157	67	77	109	0	0	0	0	0	24	5			
3601285	01S/01W-10L01S	W MILL CREEK #2	<input type="checkbox"/>	1,548	939	814	1,123	1,076	1,100	2,096	1,399	2,537	2,403	2,349	2,157				
3601286	01S/02W-21E02S	W MAGUET #3	<input checked="" type="checkbox"/>	0	3	0	0	0	1	0	0	0	0	0	0				
3601287	01S/02W-21B02S	W EAST LUGONIA #3	<input type="checkbox"/>	319	333	293	358	267	314	8	83	167	52	18	66				
3601288	01S/01W-11Q01S	W MILL CREEK #4	<input type="checkbox"/>	855	817	903	671	745	798	775	816	128	0	387	421				
3601289	01S/03W-35E	W 4R	<input checked="" type="checkbox"/>	0	0	0	0	0	0	0	0	0	0	0	0				
3601290	01S/02W-21D01S	W EAST LUGONIA #6	<input type="checkbox"/>	243	209	169	141	138	180	0	33	16	0	0	10				
3601291	01S/03W-35G08S	W 10	<input type="checkbox"/>	196	487	664	131	101	316	0	0	0	0	0	0				
3601292	01S/03W-35G07S	W 11	<input type="checkbox"/>	772	1,077	737	117	103	561	69	75	94	108	136	96				
3601293	01S/03W-35H02S	W 12	<input checked="" type="checkbox"/>	2	0	0	0	0	0	0	0	0	0	0	0				
3601294	01S/03W-35G09S	W 13	<input type="checkbox"/>	189	646	682	362	453	466	0	0	0	0	0	0				
3601295	01S/03W-35H04S	W 14	<input type="checkbox"/>	915	1,128	871	184	83	636	0	0	0	0	0	0				
3601296	01S/03W-35H03S	W 16	<input type="checkbox"/>	545	343	587	491	1,686	730	694	1,141	473	22	0	466				
3601297	01S/03W-35G11S	W 17	<input checked="" type="checkbox"/>	249	434	507	171	0	272	0	0	0	0	0	0				
3601298	01S/03W-21H01S	W 32	<input type="checkbox"/>	322	557	1,136	800	1,095	782	0	0	0	0	0	0				
3601299	01S/04W-24K01S	W 34	<input type="checkbox"/>	246	124	1,607	853	133	593	0	0	0	0	0	0				
3601300	01S/03W-27E02S	W 40	<input checked="" type="checkbox"/>	1,278	902	1,113	1,446	1,099	1,168	0	0	0	0	0	0				
3601301	01S/03W-28H01S	W 41	<input type="checkbox"/>	1,443	1,623	1,808	1,226	1,063	1,433	465	448	404	443	366	425				
3601302	01S/02W-14H	D COOLIE HAT - MILL C	<input type="checkbox"/>	7,047	6,913	3,615	8,973	4,451	6,200	12,332	7,785	10,076	13,492	10,679	10,873				
3601308	01S/02W-19K01S	W AGATE 1	<input type="checkbox"/>	772	750	738	487	470	643	0	0	50	139	0	38				
3601586	01S/03W-15F01S	W ORANGE STREET	<input type="checkbox"/>	0	0	2,177	1,354	1,488	1,004	567	694	1,065	1,406	1,600	1,066				
3601636	01S/04W-24R	W LANGFORD	<input checked="" type="checkbox"/>	216	230	65	58	51	124	0	0	0	0	0	0				
3601637	01S/03W-30D	W	<input checked="" type="checkbox"/>	0	0	0	0	0	0	0	0	0	0	0	0				
3602031	01S/03W-21H06S	W 30-A	<input type="checkbox"/>	506	1,181	1,429	699	492	861	207	257	360	616	304	349				

WESTERN - SAN BERNARDINO WATERMASTER
TABLE 1

VERIFIED EXTRACTIONS - FILED
SAN BERNARDINO BASIN AREA

RECRD TN NUMBER	STATE WELL NUMBER	WELL LOCAL TYPE DESIGNATION	FC	-----BASE YEARS-----							-----CALENDAR YEAR EXTRACTIONS-----						
				1959	1960	1961	1962	1963	AVG	2008	2009	2010	2011	2012	AVG		
3602032	01S/03W-22A02S	W 35	<input type="checkbox"/>	1959	1960	1961	1962	1963	AVG	2008	2009	2010	2011	2012	AVG		
3602036	01S/03W-21H07S	W 31-A	<input type="checkbox"/>			50	273	140	93	0	0	0	0	0	0		
3602065	01S/03W-32J02S	W LEE WELL	<input checked="" type="checkbox"/>	114	97	114	676	1,244	384	0	0	0	0	106	21		
3602065-	01S/03W-32J02S	W LEE WELL	<input type="checkbox"/>				88	80	99	0	0	0	0	0	0		
3602082	02S/03W-03K01S	W 36 (CEMETERY)	<input type="checkbox"/>					215	43	216	189	180	181	177	189		
3602106	01S/03W-22A01S	W	<input checked="" type="checkbox"/>	323	292				123	0	0	0	0	0	0		
3602109	01S/03W-31B01S	W 4, BRYN MAWR	<input type="checkbox"/>	0	0	0	708	554	252	0	0	0	0	0	0		
3602211	01S/03W-26C01S	W 37 SYLVAN PARK	<input type="checkbox"/>						0	0	0	0	0	0	0		
3602346	01S/03W-28K01S	W NEW YORK ST. WEL	<input type="checkbox"/>						0	1,217	1,009	1,000	945	843	1,003		
3602351	01S/02W-13A01S	W MILL CREEK 0-A	<input type="checkbox"/>						0	1	0	0	0	0	0		
3602653	01S/02W-19J01S	W 2	<input checked="" type="checkbox"/>						0	0	0	0	0	0	0		
3602654	01S/02W-19J02S	W CRAFTON	<input type="checkbox"/>						0	421	514	342	144	392	363		
3602791	01S/02W-20B01S	W EAST LUGONIA #4	<input type="checkbox"/>						0	0	0	88	0	0	18		
3602792	01S/02W-19A01S	W AGATE #2	<input type="checkbox"/>						0	1,551	1,910	1,199	83	278	1,004		
3602895	01S/03W-13H02S	W AIRPORT #1	<input type="checkbox"/>						0	1,369	1,285	1,426	1,367	1,695	1,428		
3602896	01S/02W-20D01S	W MADEIRA	<input type="checkbox"/>						0	667	626	555	555	32	487		
3603045	01S/01W-09J01S	W MILL CK #2A	<input type="checkbox"/>						0	0	256	9	0	0	53		
3603655	01S/03W-29Q01S	W #38	<input type="checkbox"/>						0	1,701	1,646	1,897	2,037	1,809	1,818		
3603656	01S/03W-14E01S	W CHURCH STREET	<input type="checkbox"/>						0	172	253	204	679	1,115	485		
3603760	01S/03W-29Q02S	W WELL 39	<input type="checkbox"/>						0	302	1,086	935	999	1,082	881		
3603761	01S/03W-18R	W CALIF. ST. IRRIGATIO	<input type="checkbox"/>						0	588	654	501	509	627	576		
3603762	01S/03W-13M	W AIRPORT 2	<input type="checkbox"/>						0	754	888	346	102	248	468		
3603766	01S/03W-10K01S	W NORTH ORANGE #1	<input type="checkbox"/>						0	2,232	1,823	1,208	614	2,043	1,584		
3603767	01S/03W-10K02S	W NORTH ORANGE #2	<input type="checkbox"/>						0	2,741	1,760	1,987	1,024	2,087	1,920		
3603943	01S/03W-15N	W WEATHERWAX #2	<input type="checkbox"/>						0	32	33	32	32	55	37		
TOTALS FOR REDLANDS, CITY OF				25,909	25,499	26,909	26,913	22,351	25,516	32,354	28,267	28,960	31,908	31,918	30,681		
REES & PERRICONE RANCH																	
3602171	01S/02W-18M	W 1	<input checked="" type="checkbox"/>					0	0	0	0	0	0	0	0		
TOTALS FOR REES & PERRICONE RANCH								0	0	0	0	0	0	0	0		

WESTERN - SAN BERNARDINO WATERMASTER
TABLE 1

VERIFIED EXTRACTIONS - FILED
SAN BERNARDINO BASIN AREA

RECRD TN NUMBER	STATE WELL NUMBER	WELL LOCAL TYPE DESIGNATION	FC	-----BASE YEARS-----							AVG	-----CALENDAR YEAR EXTRACTIONS-----															
				1959	1960	1961	1962	1963	1963	1963		2008	2009	2010	2011	2012	AVG										
REES-REES RANCHES INC																											
3600018	01S/02W-29P	W GRREES 2	<input type="checkbox"/>	10	163	452	88	330	330	209	0	0	0	0	0	0	0	0									
TOTALS FOR REES-REES RANCHES INC														10	163	452	88	330	209	0	0	0	0	0	0	0	
REYNOLDS, BILL																											
3600981	01S/02W-21H01S	W	<input checked="" type="checkbox"/>	3	3	3	3	3	3	3	0	0	0	0	0	0	0	0									
TOTALS FOR REYNOLDS, BILL														3	3	3	3	3	3	0	0	0	0	0	0	0	0
RIALTO, CITY OF																											
3601085	01N/04W-31N02S	W CITY 4 / #1	<input checked="" type="checkbox"/>	585	775	875	575	470	470	656	0	0	0	0	0	0	0	0									
3601263	01N/05W-23Q01S	W CITY #1	<input type="checkbox"/>	1,035	169	334	481	0	404	404	241	1	0	0	0	0	0	48									
3601718	01N/05W-22M	D FILTER	<input type="checkbox"/>	624	626	625	587	624	617	617	1,165	1,123	1,210	1,171	1,311	1,196	1,196	1,196									
3601929	01S/04W-06C04S	W CITY #6	<input type="checkbox"/>	374	52	0	458	0	177	155	2,565	1,961	2,102	1,336	842	1,761	1,761	1,761									
3602080	01N/05W-23Q02S	W CITY #2	<input type="checkbox"/>					773	0	0	147	23	33	0	24	45	45	45									
3602848	01N/05W-36B01S	W CITY #3	<input type="checkbox"/>						0	0	0	0	0	0	0	0	0	0									
3603030	01S/04W-06B01S	W CITY #5	<input type="checkbox"/>						0	0	2,427	2,605	1,980	870	932	1,763	1,763	1,763									
3603538	01S/04W-06H04S	W CITY #4A	<input type="checkbox"/>						0	0	2,427	2,605	1,980	870	932	1,763	1,763	1,763									
TOTALS FOR RIALTO, CITY OF														2,618	1,622	1,834	2,101	1,867	2,008	6,545	5,713	5,325	3,377	3,109	4,814	4,814	
RIEDMAN, FRED M																											
3601629	01S/03W-03P	W 1	<input checked="" type="checkbox"/>	230	230	230	230	15	187	187	0	0	0	0	0	0	0	0									
TOTALS FOR RIEDMAN, FRED M														230	230	230	230	15	187	0	0	0	0	0	0	0	0
RIVAS, RAMON																											
3600016	01S/04W-24J	W REES 4	<input checked="" type="checkbox"/>	30	43	0	0	0	15	15	0	0	0	0	0	0	0	0									
TOTALS FOR RIVAS, RAMON														30	43	0	0	0	15	0	0	0	0	0	0	0	0
RIVENDELL LAND COMPANY																											
3601751	01S/03W-21E	W ALABAMA/CHRISTINA	<input type="checkbox"/>	1,302	1,403	700	865	793	1,013	1,013	0	0	0	0	0	0	0	0									
TOTALS FOR RIVENDELL LAND COMPANY														1,302	1,403	700	865	793	1,013	0	0	0	0	0	0	0	0
ROBBINS, H W																											
3602170	01S/02W-31M	W	<input type="checkbox"/>					18	4	4	5	5	5	5	5	5	5	5									

WESTERN - SAN BERNARDINO WATERMASTER
TABLE 1

VERIFIED EXTRACTIIONS - FILED
SAN BERNARDINO BASIN AREA

RECRD TN NUMBER	STATE WELL NUMBER	WELL LOCAL TYPE DESIGNATION	FC	-----BASE YEARS-----					AVG	-----CALENDAR YEAR EXTRACTIIONS-----																										
				1959	1960	1961	1962	1963		18	4	2008	2009	2010	2011	2012	AVG																			
TOTALS FOR ROBBINS, H W														5	5	5	5	5	5	5	5	5	5	5	5	5	5									
SAN BERNARDINO AVE WATER CO.																																				
3600125	01S/03W-14P	W 1	<input type="checkbox"/>	371	303	394	352	298	344	344	0	0	0	0	0	0	0	0	0	0	0	0	0													
TOTALS FOR SAN BERNARDINO AVE WATER CO.														371	303	394	352	298	344	0	0	0	0	0	0	0	0	0	0	0	0	0	0	0		
SAN BERNARDINO COUNTY - FACILITY MANAGEMENT																																				
3600468	01S/03W-30Q	W BAHR 1	<input checked="" type="checkbox"/>	511	245	243	378	179	311	311	0	0	0	0	0	0	0	0	0	0	0	0	0	0												
3601171	01S/03W-20F	W 1/CRIM	<input checked="" type="checkbox"/>	389	343	435	413	396	395	395	0	0	0	0	0	0	0	0	0	0	0	0	0	0												
3603932	01N/04W-35L06S	W COUNTY HOSP-GIBE	<input type="checkbox"/>	200	200	200	200	200	200	200	118	0	4	0	0	0	0	0	0	0	0	0	0	24												
3603934	02N/05W-33F	W GLEN HELEN 3	<input type="checkbox"/>	428	330	410	308	207	337	337	265	808	206	34	193	301																				
3603935	02N/05W-33G01S	W GLEN HELEN 4	<input type="checkbox"/>	208	285	399	256	179	265	265	16	18	274	362	111	156																				
3603936	02N/05W-33D01S	W GLEN HELEN #5	<input type="checkbox"/>						0	0	2	0	290	314	115	144																				
3603937	02N/05W-33G02S	W GLEN HELEN #6	<input type="checkbox"/>						0	0	626	354	266	148	447	368																				
TOTALS FOR SAN BERNARDINO COUNTY - FACILITY MANAGEM														1,736	1,403	1,687	1,555	1,161	1,508	1,027	1,180	1,040	858	866	994											
SAN BERNARDINO COUNTY - REGIONAL PARKS																																				
3603933	01N/05W-04B	W GLEN HELEN 1A (2)	<input type="checkbox"/>						0	0	34	40	39	4	39	31																				
TOTALS FOR SAN BERNARDINO COUNTY - REGIONAL PARKS																			0	34	40	39	4	39	31											
SAN BERNARDINO COUNTY FLOOD CONTROL																																				
3601130	01S/03W-32D	W NICK'S WELL	<input type="checkbox"/>	389	401	501	464	290	409	409	149	190	189	0	0	106																				
3603900	01S/02W-04N	W DOMESTIC WELL NO.	<input type="checkbox"/>						0	0	4	4	4	10	4	5																				
TOTALS FOR SAN BERNARDINO COUNTY FLOOD CONTROL														389	401	501	464	290	409	153	194	193	10	4	10	4	4	111								
SAN BERNARDINO VALLEY M.W.D.																																				
3603116	01S/03W-13Q01S	W SB AVE #1/BIG BEAR	<input type="checkbox"/>						0	0	761	462	291	618	875	601																				
3603141	01S/04W-04E01S	W 9TH ST.	<input checked="" type="checkbox"/>						0	0	0	0	0	0	0	0																				
3603174	01S/04W-04F02S	W PERRIS ST	<input type="checkbox"/>						0	0	0	0	0	0	0	0																				
3603944	01S/04W-22C06S	W DE-WATERING #1	<input type="checkbox"/>						0	0	0	290	0	0	0	58																				
3603945	01S/04W-22F01S	W DE-WATERING #2	<input type="checkbox"/>						0	0	0	0	0	0	0	0																				
3603964	01S/04W-05F02S	W 9TH STREET NORTH	<input type="checkbox"/>						0	0	-	-	-	-	1,565	313																				
3603965	01S/04W-05F01S	W 9TH STREET SOUTH	<input type="checkbox"/>						0	0	-	-	-	-	1,350	270																				

WESTERN - SAN BERNARDINO WATERMASTER

TABLE 1

VERIFIED EXTRACTS - FILED
SAN BERNARDINO BASIN AREA

RECRD TN NUMBER	STATE WELL NUMBER	WELL LOCAL TYPE DESIGNATION	FC	-----BASE YEARS-----							AVG	-----CALENDAR YEAR EXTRACTS-----						
				1959	1960	1961	1962	1963	1963	1963		2008	2009	2010	2011	2012	AVG	
TOTALS FOR SAN BERNARDINO VALLEY M.W.D.																		
SAN BERNARDINO, CITY OF																		
3600034	01S/04W-16H	W SMITH 1	<input checked="" type="checkbox"/>	90	85	76	79	79	66	0	0	0	0	0	0	0	0	0
3600035	01S/04W-15M01S	W	<input checked="" type="checkbox"/>	85	80	82	12	52	52	0	0	0	0	0	0	0	0	0
3600222	01S/04W-11Q01S	W MCFARLAND JOHNS	<input checked="" type="checkbox"/>	195	210			81	81	0	0	0	0	0	0	0	0	0
3600320	01N/05W-22M	D MT VERNON	<input type="checkbox"/>	730	730	730	730	730	730	0	0	0	0	0	0	0	0	0
3600709	02N/05W-19Q01S	W VINCENT	<input checked="" type="checkbox"/>	0	0	0	0	0	0	0	0	0	0	0	0	0	0	0
3600710	02N/05W-19K01S	W CAJON CYN	<input type="checkbox"/>	0	0	0	0	0	0	495	255	375	447	220	358			
3600711	01N/04W-07F01S	W DEVIL CANYON #2	<input type="checkbox"/>	867	726	705	617	295	642	1,040	964	1,525	1,318	665	1,102			
3600712	01N/04W-08M01S	W DEVIL CANYON #1	<input type="checkbox"/>	141	1	0	0	0	28	659	1,192	1,053	1,070	892	973			
3600713	01N/05W-36R01S	W LYTLE CREEK # 3-1	<input type="checkbox"/>	378	85	314	199	360	267	0	0	0	0	0	0	0	0	
3600714	01N/04W-16E01S	W NEWMARK #1	<input type="checkbox"/>	163	643	624	531	571	506	495	223	132	257	253	272			
3600715	01N/04W-16E02S	W NEWMARK #2	<input type="checkbox"/>	0	205	233	1,188	623	450	808	415	188	383	741	507			
3600716	01N/04W-16E03S	W NEWMARK #3	<input type="checkbox"/>	964	919	1,093	576	839	878	1,588	1,312	1,154	1,545	1,504	1,421			
3600717	01N/04W-32D03S	W 19TH ST #1	<input type="checkbox"/>	146	221	30	46	163	121	348	0	0	0	0	70			
3600718	01N/04W-32D04S	W 19TH ST #2	<input type="checkbox"/>	365	40	96	0	0	100	289	1,171	1,085	786	617	790			
3600719	01N/04W-27G01S	W 30TH ST.	<input type="checkbox"/>	1,173	1,086	922	998	1,005	1,037	1,810	1,478	1,176	272	136	974			
3600720	01N/04W-27M02S	W 27TH ST. & ACACIA	<input type="checkbox"/>	0	134	481	293	212	224	512	261	152	229	435	318			
3600721	01N/04W-27M01S	W 25TH & N. "E" ST.	<input type="checkbox"/>	0	194	407	313	395	262	0	0	0	0	0	0	0	0	
3600722	01S/04W-03D01S	W 11TH & E ST (ACACIA)	<input checked="" type="checkbox"/>	0	0	0	0	0	0	0	0	0	0	0	0	0	0	
3600723	01S/04W-10F01S	W HANFORD 1	<input checked="" type="checkbox"/>	146	489	345	0	0	196	0	0	0	0	0	0	0	0	
3600724	01S/04W-10F05S	W HANFORD 2	<input checked="" type="checkbox"/>	0	0	0	0	0	0	0	0	0	0	0	0	0	0	
3600725	01N/04W-34G01S	W 17 ST/SIERRA WAY #	<input type="checkbox"/>	1,102	1,155	1,245	405	538	889	0	0	0	0	0	0	0	0	
3600726	01N/04W-34G03S	W 16TH ST & SIERRA W	<input type="checkbox"/>	354	305	91	12	29	158	1,554	2,382	2,002	2,162	2,487	2,117			
3600727	01N/04W-26E02S	W LYNWOOD	<input type="checkbox"/>	1,238	927	1,475	1,365	1,180	1,237	1,460	1,071	1,049	302	244	825			
3600728	01N/04W-27A01S	W WATERMAN AVE.	<input type="checkbox"/>	1,265	1,724	2,214	1,404	1,122	1,546	1,293	1,163	1,247	1,563	1,570	1,367			
3600729	01N/04W-35M03S	W GILBERT ST.	<input type="checkbox"/>	1,348	940	1,573	2,522	2,574	1,791	1,012	78	88	36	222	287			
3600730	01S/04W-02K01S	W ANTIL #3	<input checked="" type="checkbox"/>	0	0	0	0	0	0	0	0	0	0	0	0	0	0	
3600731	01S/04W-02K02S	W ANTIL #5	<input type="checkbox"/>	750	684	1,295	642	750	824	0	0	0	0	0	0	0	0	
3600732	01S/04W-02K05S	W ANTIL #2	<input checked="" type="checkbox"/>	0	0	0	0	0	0	0	0	0	0	0	0	0	0	
3600733	01S/04W-02K04S	W ANTIL #1	<input checked="" type="checkbox"/>	0	0	0	0	0	0	0	0	0	0	0	0	0	0	

WESTERN - SAN BERNARDINO WATERMASTER
TABLE 1

VERIFIED EXTRACTS - FILED
SAN BERNARDINO BASIN AREA

RECRD TN NUMBER	STATE WELL NUMBER	WELL LOCAL TYPE DESIGNATION	FC	-----BASE YEARS-----											-----CALENDAR YEAR EXTRACTS-----						
				1959	1960	1961	1962	1963	AVG	2008	2009	2010	2011	2012	AVG						
3600734	01S/04W-02K03S	W ANTL #4	<input type="checkbox"/>	1,052	458	411	478	367	367	553	0	0	0	0	0	0	0	0	0	0	0
3600735	01S/04W-09P01S	W BIRCH ST.	<input checked="" type="checkbox"/>	0	0	0	0	0	0	0	0	0	0	0	0	0	0	0	0	0	0
3600736	01S/04W-09J01S	W SOUTH G ST	<input checked="" type="checkbox"/>	127	83	103	254	153	144	144	0	0	0	0	0	0	0	0	0	0	0
3600737	01S/04W-10N06S	W MILL & D	<input type="checkbox"/>	66	143	271	32	158	134	134	429	377	397	502	398	421	0	0	0	0	0
3600738	01N/04W-06J	D DEVIL CYN DIVERSIO	<input type="checkbox"/>	1,117	768	549	836	592	772	772	0	0	0	0	0	0	0	0	0	0	0
3600739	01N/05W-06E	D LYTLE CK DIV.	<input type="checkbox"/>	1,069	994	1,286	1,403	1,279	1,206	1,206	0	0	0	0	0	0	0	0	0	0	0
3601114	01N/04W-35C01S	W PERRIS HILL 2	<input checked="" type="checkbox"/>	12	358	353	0	0	145	145	0	0	0	0	0	0	0	0	0	0	0
3601115	01N/04W-26P03S	W PERRIS HILL 5	<input type="checkbox"/>	33	342	519	899	832	525	525	1	1	1	0	0	0	0	0	0	0	1
3601116	01N/04W-35C02S	W PERRIS HILL 3	<input checked="" type="checkbox"/>	0	0	0	0	0	0	0	0	0	0	0	0	0	0	0	0	0	0
3601117	01N/04W-35C03S	W PERRIS HILL 4	<input type="checkbox"/>	1,559	1,464	811	386	408	926	926	0	1	1	0	1	0	0	0	0	0	1
3601316	01S/04W-23N	W INTERCITY MUTUAL 0	<input type="checkbox"/>	238	238	238	238	238	238	238	0	0	0	0	0	0	0	0	0	0	0
3601588	01N/04W-31H	W STATE 1	<input type="checkbox"/>	68	75	74	64	72	71	71	0	0	0	0	0	0	0	0	0	0	0
3601626	01S/04W-10D	W CITYLOTS	<input checked="" type="checkbox"/>	26	23	28	27	24	26	26	0	0	0	0	0	0	0	0	0	0	0
3601843	01N/05W-03H01S	W CAJON NO 1	<input type="checkbox"/>	179	13	8	19	6	45	45	0	0	0	0	0	0	0	0	0	0	0
3601844	01N/05W-03H02S	W CAJON NO 2	<input type="checkbox"/>	856	807	630	748	742	757	757	1,094	1,160	1,366	1,673	1,443	1,347	0	0	0	0	0
3601845	01N/04W-30M01S	W MALLORY NO. 3	<input type="checkbox"/>	5	19	28	33	33	24	24	337	593	356	903	667	571	0	0	0	0	0
3601878	01N/04W-29E01S	W DARBY	<input type="checkbox"/>	181	123	86	17	146	111	111	0	0	0	0	0	0	0	0	0	0	0
3601879	01N/04W-29E	W GARDENA	<input type="checkbox"/>	205	182	182	136	103	162	162	0	0	0	0	0	0	0	0	0	0	0
3601880	01N/04W-29F01S	W COLIMA	<input checked="" type="checkbox"/>	227	141	193	221	118	180	180	0	0	0	0	0	0	0	0	0	0	0
3602060	01S/04W-24P	W JOHANSSON, RUNE	<input checked="" type="checkbox"/>	111	71	125	60	79	89	89	0	0	0	0	0	0	0	0	0	0	0
3602066	01S/04W-02B	W 1, VAN LOON/BELVAN	<input type="checkbox"/>	33	49	25	26	25	32	32	0	0	0	0	0	0	0	0	0	0	0
3602067	01N/04W-35K	W 2-GILBERT/CANYON	<input type="checkbox"/>	120	110	74	177	164	129	129	0	0	0	0	0	0	0	0	0	0	0
3602081	01N/04W-27B01S	W 31ST ST. & MT VIEW	<input type="checkbox"/>					1,019	204	204	298	361	141	240	205	249	0	0	0	0	0
3602122	01S/04W-23R03S	W ROSEWOOD	<input checked="" type="checkbox"/>	111	154	114	2	0	76	76	0	0	0	0	0	0	0	0	0	0	0
3602123	01S/04W-14J	W NORMAN RD	<input type="checkbox"/>	485	443	526	50	58	312	312	0	0	0	0	0	0	0	0	0	0	0
3602124	01S/04W-14J	W CENTRAL AVE	<input checked="" type="checkbox"/>	179	159	158	151	80	145	145	0	0	0	0	0	0	0	0	0	0	0
3602125	01S/04W-24F04S	W GOULD #1 OLD	<input checked="" type="checkbox"/>	150	167	226	144	91	156	156	0	0	0	0	0	0	0	0	0	0	0
3602126	01S/04W-24F	W GOULD #2 NEW	<input checked="" type="checkbox"/>			0	105	84	38	38	0	0	0	0	0	0	0	0	0	0	0
3602128	01S/04W-14A	W GIFFORD PK/ #1	<input checked="" type="checkbox"/>	50	50	50	50	51	50	50	0	0	0	0	0	0	0	0	0	0	0
3602205	01N/04W-06H01S	W DEVIL CANYON #4	<input type="checkbox"/>						0	0	28	13	4	5	3	11	0	0	0	0	0
3602206	01N/04W-06H02S	W DEVIL CANYON #3	<input type="checkbox"/>						0	0	141	56	9	0	1	41	0	0	0	0	0
3602252	01S/04W-14B03S	W 2	<input checked="" type="checkbox"/>						0	0	0	0	0	0	0	0	0	0	0	0	0

WESTERN - SAN BERNARDINO WATERMASTER
TABLE 1

VERIFIED EXTRACTIONS - FILED
SAN BERNARDINO BASIN AREA

RECRD TN NUMBER	STATE WELL NUMBER	WELL LOCAL TYPE DESIGNATION	FC	-----BASE YEARS-----							-----CALENDAR YEAR EXTRACTIONS-----							
				1959	1960	1961	1962	1963	AVG	2008	2009	2010	2011	2012	AVG			
3602264	01N/04W-27N01S	W 23RD ST.	<input checked="" type="checkbox"/>						0	0	0	0	0	0	0	0	0	0
3602265	01S/04W-03J05S	W 7TH ST.	<input type="checkbox"/>						0	140	226	79	165	216	165			
3602285	01S/04W-15D05S	W 15D5	<input checked="" type="checkbox"/>	8	8	8	8	1	7	0	0	0	0	0	0	0	0	0
3602399	01N/04W-16E04S	W NEWMARK #4	<input type="checkbox"/>						0	1,554	366	901	1,527	1,573	1,184			
3602400	01N/04W-32N01S	W BASELINE & CALIFOR	<input type="checkbox"/>						0	339	347	160	172	102	224			
3602401	01N/04W-27A02S	W LEROY	<input type="checkbox"/>						0	822	883	335	579	612	646			
3602422	01S/04W-02K08S	W ANTIL 6	<input type="checkbox"/>						0	0	81	5	27	0	23			
3602426	02N/05W-19Q01S	D VINCENT (CAJON CR	<input type="checkbox"/>	1,604	770	966	2,141	960	1,288	498	403	521	724	546	538			
3602521	01S/04W-23N04S	W NO 2	<input checked="" type="checkbox"/>						0	0	0	0	0	0	0	0	0	
3602821	01N/05W-03A02S	W CAJON #3	<input type="checkbox"/>						0	954	823	578	696	946	799			
3602844	01N/04W-08M02S	W DEVIL CANYON #5	<input type="checkbox"/>						0	272	458	282	148	210	274			
3603027	01N/05W-36J01S	W LYTLE CK #2	<input type="checkbox"/>						0	652	659	500	737	622	634			
3603206	01S/04W-04D02S	W OLIVE/GARNER	<input type="checkbox"/>						0	1,306	1,194	1,225	1,739	1,113	1,315			
3603207	01S/04W-04B04S	W 10TH & J ST	<input type="checkbox"/>						0	1,620	2,075	1,797	2,507	1,723	1,944			
3603208	01N/04W-34G04	W 17TH ST. & SIERRA #2	<input type="checkbox"/>						0	282	76	279	17	16	134			
3603471	02N/05W-19R04S	W KENWOOD #1	<input type="checkbox"/>						0	1,166	1,132	1,423	1,770	1,400	1,378			
3603472	01N/04W-14P03S	W 40TH & VALENCIA	<input type="checkbox"/>						0	67	21	217	141	181	125			
3603579	01N/04W-06A02S	W DEVIL CYN #7	<input type="checkbox"/>						0	92	66	67	77	81	77			
3603580	01N/04W-06A01S	W DEVIL CYN #6	<input type="checkbox"/>						0	194	182	176	201	196	190			
3603581	01S/04W-22C05S	W CENTURY	<input type="checkbox"/>						0	950	830	895	541	355	714			
3603582	01S/04W-15P05S	W CHANDLER	<input type="checkbox"/>						0	800	857	633	754	1,133	835			
3603649	01S/03W-07A06S	W IVDA 11 (NORTON #11	<input type="checkbox"/>						0	70	101	61	59	84	75			
3603688	01S/04W-03D04S	W EPA #1	<input type="checkbox"/>						0	1,986	1,526	2,003	2,328	2,269	2,022			
3603689	01S/04W-03C03S	W EPA #2	<input type="checkbox"/>						0	2,165	2,260	2,243	2,337	2,680	2,337			
3603690	01S/04W-03C04S	W EPA #3	<input type="checkbox"/>						0	3,412	3,198	3,069	3,112	2,563	3,071			
3603691	01S/04W-03B03S	W EPA #4	<input type="checkbox"/>						0	2,107	2,201	1,918	2,011	1,874	2,022			
3603692	01S/04W-03A04S	W EPA #5	<input type="checkbox"/>						0	2,379	2,430	1,227	204	1,083	1,465			
3603693	01N/04W-16M03S	W EPA #6	<input type="checkbox"/>						0	529	593	438	513	551	525			
3603694	01N/04W-16M04S	W EPA #7	<input type="checkbox"/>						0	2,074	2,130	1,917	884	1,799	1,761			
3603786	01N/04W-33R	W EPA 108	<input type="checkbox"/>						0	2,362	2,399	1,882	2,070	2,256	2,194			
3603787	01N/04W-33P	W EPA 109	<input type="checkbox"/>						0	1,997	1,751	1,431	1,402	1,430	1,602			
3603788	01N/04W-33N	W EPA 110	<input type="checkbox"/>						0	2,493	2,253	1,683	1,464	1,649	1,908			

WESTERN - SAN BERNARDINO WATERMASTER
TABLE 1

VERIFIED EXTRACTIONS - FILED
SAN BERNARDINO BASIN AREA

RECRD TN NUMBER	STATE WELL NUMBER	WELL LOCAL TYPE DESIGNATION	FC	-----BASE YEARS-----							AVG	-----CALENDAR YEAR EXTRACTIONS-----						
				1959	1960	1961	1962	1963	1963	1963		2008	2009	2010	2011	2012	AVG	
3603789	01N/04W-32R	W EPA 111	<input type="checkbox"/>								0	2,284	2,129	2,497	2,469	2,206	2,317	
3603790	01N/04W32Q	W EPA 112	<input type="checkbox"/>								0	2,472	2,177	1,698	1,329	1,665	1,868	
3603791	02N/05W-19R05S	W KENWOOD 2	<input type="checkbox"/>								0	1,850	1,419	1,369	1,608	1,362	1,522	
3603792	01N/05W-03A03S	W CAJON 4	<input type="checkbox"/>								0	1,558	1,348	1,283	1,397	2,285	1,574	
3603917	01N/04W-33R03S	W EPA 108S	<input type="checkbox"/>								0	924	925	891	929	765	887	
3603960	01S/04W-15P06S	W ORANGE SHOW RDP	<input type="checkbox"/>								0	255	20	1	0	0	55	
3690927	01N/03W-31B01S	W PATTON 6	<input checked="" type="checkbox"/>								0	0	0	0	0	0	0	
TOTALS FOR SAN BERNARDINO, CITY OF				21,371	19,795	22,073	20,637	19,269	20,629	58,316	54,066	49,185	50,331	50,250	52,430			
SECHREST, RALPH F.																		
3600483	01S/02W-31F	W GPHRRCH1	<input checked="" type="checkbox"/>	87	71	192	906	141	279	0	0	0	0	0	0	0		
TOTALS FOR SECHREST, RALPH F.				87	71	192	906	141	279	0	0	0	0	0	0	0		
SELBY DR & MRS																		
3600017	01S/02W-29P	W GRREES 3	<input type="checkbox"/>	137	64	278	171	76	145	0	0	0	0	0	0	0		
TOTALS FOR SELBY DR & MRS				137	64	278	171	76	145	0	0	0	0	0	0	0		
SMITH TRACT WELL COMPANY																		
3600001	01S/03W-21R02S	W 11	<input checked="" type="checkbox"/>	270	177	56	0	101	0	0	0	0	0	0	0	0		
3600001-	01S/03W-21R01S	W	<input checked="" type="checkbox"/>				127	25	0	0	0	0	0	0	0	0		
TOTALS FOR SMITH TRACT WELL COMPANY				270	177	56	0	127	126	0	0	0	0	0	0	0		
SOJKA, DONALD R.																		
3601173	01S/03W-32K	W	<input checked="" type="checkbox"/>	91	82	99	86	84	88	0	0	0	0	0	0	0		
TOTALS FOR SOJKA, DONALD R.				91	82	99	86	84	88	0	0	0	0	0	0	0		
SOLANO WELL NO 3																		
3602003	01S/02W-16C	W 3	<input type="checkbox"/>				202	179	76	64	74	62	48	76	65			
TOTALS FOR SOLANO WELL NO 3							202	179	76	64	74	62	48	76	65			
SOMERS, R.																		
3601093	01N/04W-24H	D SPRING	<input checked="" type="checkbox"/>	1	1	1	1	1	1	0	0	0	0	0	0	0		
TOTALS FOR SOMERS, R.				1	1	1	1	1	1	0	0	0	0	0	0	0		

WESTERN - SAN BERNARDINO WATERMASTER
TABLE 1

VERIFIED EXTRACTIIONS - FILED
SAN BERNARDINO BASIN AREA

RECRD TN NUMBER	STATE WELL NUMBER	WELL LOCAL TYPE DESIGNATION	FC	-----BASE YEARS-----							AVG	-----CALENDAR YEAR EXTRACTIIONS-----														
				1959	1960	1961	1962	1963	1963	1963		2008	2009	2010	2011	2012	AVG									
SOUTHERN CALIFORNIA EDISON																										
3690723	01S/04W-10F01S	W HANFORD1	<input checked="" type="checkbox"/>					883	883	883	883	353														
TOTALS FOR SOUTHERN CALIFORNIA EDISON																										
SOUZA, JOHN																										
3601084	01S/02W-20K	W	<input checked="" type="checkbox"/>	7	7	9	10	9	9	8	8	8														
TOTALS FOR SOUZA, JOHN																										
SPRING PACIFIC PROPERTY LLC																										
3601750	01S/03W-18L	W ACQUIL/MARIGOLD	<input checked="" type="checkbox"/>	390	1,072	610	930	1,392	1,392	879	879															
TOTALS FOR SPRING PACIFIC PROPERTY LLC																										
STORKSON, DAVID D.																										
3600083	01N/05W-06P	W 1	<input type="checkbox"/>	35	30	20	40	35	32	32	65	57	64	30	59	55										
36002664	01N/05W-06M01S	W SPRING NO 1	<input type="checkbox"/>						0	35	31	28	26	30	30											
TOTALS FOR STORKSON, DAVID D.																										
SUNRISE RANCH PARTNERSHIP																										
36000599	01S/02W-13F	W 1	<input checked="" type="checkbox"/>	444	397	452	381	381	411	411	0	0	0	0	0	0										
3600600	01S/02W-14L	W SUNRISE 2	<input checked="" type="checkbox"/>	240	226	253	238	159	223	223	0	0	0	0	0	0										
3600601	01S/02W-14F	W SUN 3A	<input checked="" type="checkbox"/>	321	317	313	301	230	296	296	0	0	0	0	0	0										
3600602	01S/02W-15P	W SUNRISE 4	<input checked="" type="checkbox"/>	294	230	234	254	238	250	250	0	0	0	0	0	0										
3600603	01S/02W-15G	W SUNRISE 5	<input checked="" type="checkbox"/>	238	214	230	222	206	222	222	0	0	0	0	0	0										
3601640	01S/02W-14N	W SUN 6	<input checked="" type="checkbox"/>	320	309	294	317	381	324	324	0	0	0	0	0	0										
3601969	01S/02W-14L	W SUNRISE 7	<input checked="" type="checkbox"/>			343	324	397	213	213	0	0	0	0	0	0										
TOTALS FOR SUNRISE RANCH PARTNERSHIP																										
				1,857	1,693	2,119	2,037	1,992	1,940	1,940	0	0	0	0	0	0										
SYCAMORE HEIGHTS WATER COMPANY INC																										
3601837	01N/03W-34B	W HERCULES	<input checked="" type="checkbox"/>	210			0	0	42	42	0	0	0	0	0	0										
3601838	01N/03W-34A	W WALKISHA	<input checked="" type="checkbox"/>	210	52	52	52	52	84	84	0	0	0	0	0	0										
TOTALS FOR SYCAMORE HEIGHTS WATER COMPANY INC																										
				420	52	52	52	52	126	126	0	0	0	0	0	0	0									
TENNESSEE MUTUAL WELL COMPANY																										
3601161	01S/03W-16L	W PIONEER 1	<input type="checkbox"/>	537	501	622	516	476	530	530	208	212	173	178	178	190										

WESTERN - SAN BERNARDINO WATERMASTER

TABLE 1

VERIFIED EXTRACTIONS - FILED
SAN BERNARDINO BASIN AREA

RECRD TN NUMBER	STATE WELL TYPE DESIGNATION	WELL LOCAL COMPANY	FC	-----BASE YEARS-----							-----CALENDAR YEAR EXTRACTIONS-----													
				1959	1960	1961	1962	1963	AVG	2008	2009	2010	2011	2012	AVG									
TOTALS FOR TENNESSEE MUTUAL WELL COMPANY													537	501	622	516	476	530	208	212	173	178	178	190
TENNESSEE WATER COMPANY																								
3600474	01S/03W-16L	W 1	<input type="checkbox"/>	530	530	540	540	550	538	309	303	226	192	211	248									
TOTALS FOR TENNESSEE WATER COMPANY													530	530	540	540	550	538	309	303	226	192	211	248
TERRACE WATER COMPANY																								
3601684	01S/04W-08F06S	W LARGE 1	<input checked="" type="checkbox"/>	0	191	263	280		147	0	0	0	0	0	0									
3601684-	01S/04W-08F12S	W #1 SMALL, 50 HP SUB	<input type="checkbox"/>					455	91	255	399	268	392	252	313									
3601685	01S/04W-08F14S	W SMALL 2	<input checked="" type="checkbox"/>	66	0	0	0	0	13	0	0	0	0	0	0									
3601686	01S/04W-08F14S	W #2 LARGE WELL, 100	<input type="checkbox"/>	1,252	730	814	732	444	794	558	389	433	314	499	439									
TOTALS FOR TERRACE WATER COMPANY													1,318	921	1,077	1,012	899	1,045	813	788	701	706	751	752
TILDEN, M WILLIAM																								
3602074	01N/03W-34B02S	W IRRIG 1	<input checked="" type="checkbox"/>	112	112	112	112	112	112	0	0	0	0	0	0									
3602075	01N/03W-34B01S	W DOM 2	<input checked="" type="checkbox"/>	36	36	36	36	36	36	0	0	0	0	0	0									
TOTALS FOR TILDEN, M WILLIAM													148	148	148	148	148	148	0	0	0	0	0	0
TRAMMELL CROW COMPANY																								
3600524	01S/03W-17L01S	W NEVADA ST	<input checked="" type="checkbox"/>	991	876	572	429	772	728	0	0	0	0	0	0									
TOTALS FOR TRAMMELL CROW COMPANY													991	876	572	429	772	728	0	0	0	0	0	0
TRI-CITY CONCRETE																								
3600935	01N/04W-31N	W WILSON 2	<input checked="" type="checkbox"/>	10	10	10	10	10	10	0	0	0	0	0	0									
3601309	01S/04W-05M	W PLANT	<input checked="" type="checkbox"/>	125	125	125	125	126	125	0	0	0	0	0	0									
TOTALS FOR TRI-CITY CONCRETE													135	135	135	135	136	135	0	0	0	0	0	0
TRI-CITY MUTUAL WATER COMPANY																								
3601823	01S/04W-23K	W	<input checked="" type="checkbox"/>	53	20	0	0	0	15	0	0	0	0	0	0									
TOTALS FOR TRI-CITY MUTUAL WATER COMPANY													53	20	0	0	0	15	0	0	0	0	0	0
TROJAN GROVES																								
3600451	01S/03W-15M	W	<input type="checkbox"/>	962	700	940	784	816	840	1	1	0	1	1	1									

WESTERN - SAN BERNARDINO WATERMASTER

TABLE 1

VERIFIED EXTRACTIONS - FILED
SAN BERNARDINO BASIN AREA

RECRD TN NUMBER	STATE WELL NUMBER	WELL LOCAL TYPE DESIGNATION	FC	-----BASE YEARS-----							AVG	-----CALENDAR YEAR EXTRACTIONS-----					
				1959	1960	1961	1962	1963	1963	1963		2008	2009	2010	2011	2012	AVG
TOTALS FOR TROJAN GROVES				962	700	940	784	816	840	840	1	1	0	0	1	1	1
UNGER, V. E.																	
3601168	01S/04W-26F	W	<input checked="" type="checkbox"/>						0	0	0	0	0	0	0	0	
TOTALS FOR UNGER, V. E.									0	0	0	0	0	0	0	0	
VICTORIA FARMS MUTUAL WATER CO																	
3602112	01S/04W-13R01S	W	<input checked="" type="checkbox"/>	335	288	320	275	266	297	0	0	0	0	0	0	0	
3602247	01S/04W-13R03S	W 2	<input checked="" type="checkbox"/>						0	0	0	0	0	0	0	0	
3602574	01S/04W-13R04S	W NO. 3	<input checked="" type="checkbox"/>						0	0	0	0	0	0	0	0	
3602714	01S/04W-13R01S	W NO 1	<input checked="" type="checkbox"/>						0	0	0	0	0	0	0	0	
TOTALS FOR VICTORIA FARMS MUTUAL WATER CO				335	288	320	275	266	297	0	0	0	0	0	0	0	
VICTORIA GUERNSEY																	
3600399	01S/04W-02D	W 1	<input checked="" type="checkbox"/>	163	248	200	160	223	199	0	0	0	0	0	0	0	
TOTALS FOR VICTORIA GUERNSEY				163	248	200	160	223	199	0	0	0	0	0	0	0	
VILLAGE LAKES																	
3600241	01S/03W-03Q	W 1-HOME	<input type="checkbox"/>	220	194	179	190	224	201	85	85	85	85	85	85	85	
TOTALS FOR VILLAGE LAKES				220	194	179	190	224	201	85	85	85	85	85	85	85	
VULCAN - CAL MAT																	
3603695	01N/05W-25Q	W HIGHLAND PLANT	<input type="checkbox"/>						0	863	0	0	0	0	0	173	
3603696	01N/05W-02N	W CAJON CK AREA D	<input type="checkbox"/>						0	27	28	27	27	27	27	27	
3603697	01N/05W-14A	W CAJON CK PLNG. "M"	<input type="checkbox"/>						0	196	196	103	107	92	139	139	
TOTALS FOR VULCAN - CAL MAT									0	1,086	224	130	134	119	339	339	
WARMINGTON, ROBERT P.																	
3600270	01S/03W-20P	W RDLNDS 1	<input checked="" type="checkbox"/>	300	248	288	153	139	226	0	0	0	0	0	0	0	
TOTALS FOR WARMINGTON, ROBERT P.				300	248	288	153	139	226	0	0	0	0	0	0	0	
WEATHERWAX, W. G.																	
3600652	01S/03W-15N01S	W REDLANDS	<input checked="" type="checkbox"/>	0	0	0	0	0	0	0	0	0	0	0	0	0	

WESTERN - SAN BERNARDINO WATERMASTER
TABLE 1

VERIFIED EXTRACTIONS - FILED
SAN BERNARDINO BASIN AREA

RECRD TN NUMBER	STATE WELL NUMBER	WELL LOCAL TYPE DESIGNATION	FC	-----BASE YEARS-----							AVG	-----CALENDAR YEAR EXTRACTIONS-----					
				1959	1960	1961	1962	1963	1963	1963		2008	2009	2010	2011	2012	AVG
TOTALS FOR WEATHERWAX, W. G.																	
				0	0	0	0	0	0	0	0	0	0	0	0	0	0
WESSON, ROBERT CRAIG																	
3601642	01S/02W-30B02S	W KING ST	<input type="checkbox"/>	133	147	180	120	116	139	139	139	8	8	4	14	14	10
TOTALS FOR WESSON, ROBERT CRAIG																	
				133	147	180	120	116	139	139	8	8	4	14	14	10	
WEST VALLEY WATER DIST																	
3600302	01N/05W-26A01S	W #03 / LOWER 2	<input checked="" type="checkbox"/>	158	259	160	0	0	115	0	0	0	0	0	0	0	0
3600303	01N/05W-26B01S	W LOWER 4	<input checked="" type="checkbox"/>	0	0	0	0	0	0	0	0	0	0	0	0	0	0
3600304	01N/05W-26A03S	W #04 / LOWER 5	<input checked="" type="checkbox"/>	816	671	611	540	804	688	0	0	0	0	0	0	0	0
3600305	01N/05W-25E01S	W #05 / LOWER 6	<input checked="" type="checkbox"/>	922	990	1,124	471	573	816	0	0	0	0	0	0	0	0
3600306	01N/05W-23P02S	W UPPER 2	<input checked="" type="checkbox"/>						0	0	0	0	0	0	0	0	0
3600307	01N/05W-23P04S	W #01 / UPPER 4	<input checked="" type="checkbox"/>	1,057	1,152	399	72	435	623	623	0	0	0	0	0	0	0
3600312	01N/05W-22M	D LYTLE CREEK	<input type="checkbox"/>	4,258	2,709	2,424	4,392	4,097	3,576	3,576	3,369	3,189	3,322	3,381	2,954	3,243	0
36000996	01N/05W-36J03S	W #08 / LORD 1	<input checked="" type="checkbox"/>	839	1,355	1,048	1,552	1,366	1,232	0	0	0	0	0	0	0	0
3600997	01N/05W-36H04S	W #07 / LORD #7	<input type="checkbox"/>	230	85	0	0	0	63	63	1,631	1,203	125	8	98	613	0
3600998	01N/05W-25E02S	W #06 / FERG 1	<input checked="" type="checkbox"/>	1,228	639	356	8	0	446	446	0	0	0	0	0	0	0
3600999	01S/04W-06J01S	W DIXON 1	<input checked="" type="checkbox"/>	531	70	435	70	9	223	223	0	0	0	0	0	0	0
3601000	01S/04W-06J02S	W #12 / DIXON 2	<input checked="" type="checkbox"/>	312	0	0	0	0	62	62	0	0	0	0	0	0	0
3601002	01N/04W-31P03S	W #09 / RAYNOR 1	<input checked="" type="checkbox"/>	338	540	554	221	148	360	360	0	0	0	0	0	0	0
3601003	01S/04W-06H02S	W #13 / RAYNOR 4	<input checked="" type="checkbox"/>	1,283	929	1,264	794	1,434	1,141	1,141	0	0	0	0	0	0	0
3601725	01N/05W-25E	D	<input checked="" type="checkbox"/>						0	0	0	0	0	0	0	0	0
3601848	01S/04W-05E05S	W #15 9TH & PENNSYLV	<input type="checkbox"/>	1,612	2,655	3,145	1,951	1,965	2,266	2,266	764	801	156	969	1,012	740	0
3601944	01N/05W-23Q01S	W #02 / LOWER 7	<input type="checkbox"/>	0	36	2,067	1,260	1,006	874	874	1,905	1,707	1,522	677	2,151	1,592	0
3602766	01S/04W-06H03S	W #30 WASHINGTON/BS	<input type="checkbox"/>						0	0	930	459	616	366	669	608	0
3602897	01N/05W-23P	W #34 GOLF COURSE	<input checked="" type="checkbox"/>						0	0	0	0	0	0	0	0	0
3603054	01N/05W-25E03S	W #35 GOLF COURSE	<input checked="" type="checkbox"/>						0	0	0	0	0	0	0	0	0
3603055	01N/05W-36H05S	W #36 LORD RANCH	<input type="checkbox"/>						0	0	0	0	0	0	0	0	0
3603769	01N/05W-25E	W #05A SYCAMORE VAL	<input type="checkbox"/>						0	0	1,319	1,024	405	312	134	639	0
3603777	01N/05W-26A06S	W #04A	<input type="checkbox"/>						0	0	1,338	1,020	766	1,694	1,571	1,278	0
3603778	01N/05W-36R06S	W #08A	<input type="checkbox"/>						0	0	1,659	2,548	692	44	5	990	0
3603902	01N/05W-23P07S	W #01A	<input type="checkbox"/>						0	0	839	765	382	246	43	455	0

WESTERN - SAN BERNARDINO WATERMASTER

TABLE 1

VERIFIED EXTRACTIONS - FILED
SAN BERNARDINO BASIN AREA

RECRD TN NUMBER	STATE WELL NUMBER	WELL LOCAL TYPE DESIGNATION	FC	-----BASE YEARS-----							-----CALENDAR YEAR EXTRACTIONS-----				
				1959	1960	1961	1962	1963	AVG	2008	2009	2010	2011	2012	AVG
TOTALS FOR WEST VALLEY WATER DIST				13,584	12,090	13,587	11,331	11,837	12,486	13,754	12,716	7,986	7,697	8,637	10,158
WILEY, RUTH NORWOOD															
3600052	01S/04W-36J	W 1	<input checked="" type="checkbox"/>					52	10	0	0	0	0	0	
TOTALS FOR WILEY, RUTH NORWOOD								52	10	0	0	0	0	0	
WILLIAMS WELL CORPORATION LTD															
3600828	01S/03W-16J	W -	<input type="checkbox"/>	721	684	765	706	595	694	394	363	421	388	460	
TOTALS FOR WILLIAMS WELL CORPORATION LTD				721	684	765	706	595	694	394	363	421	388	460	405
WOEHR MUTUAL WATER COMPANY															
36600817	01S/03W-29H	W	<input checked="" type="checkbox"/>	374	465	625	488	423	475	0	0	0	0	0	
TOTALS FOR WOEHR MUTUAL WATER COMPANY				374	465	625	488	423	475	0	0	0	0	0	0
YUHAIPAI VALLEY WATER DISTRICT															
3601280	01S/03W-29D	W SOUTH 1	<input checked="" type="checkbox"/>	50	95	51	51	51	60	0	0	0	0	0	
TOTALS FOR YUHAIPAI VALLEY WATER DISTRICT				50	95	51	51	51	60	0	0	0	0	0	0
YUCAIPA VALLEY WATER DISTRICT															
3602657	01S/01W-20D01S	W WELL NO 31	<input checked="" type="checkbox"/>						0	0	0	0	0	0	
3602658	01S/01W-20D03S	W WELL NO 32	<input checked="" type="checkbox"/>						0	0	0	0	0	0	
3602659	01S/01W-19B02S	W WELL NO 33	<input checked="" type="checkbox"/>						0	0	0	0	0	0	
3603539	01S/02W-24C01S	W YVWD 51/MILL CREEK	<input type="checkbox"/>						0	161	99	166	97	129	
TOTALS FOR YUCAIPA VALLEY WATER DISTRICT									0	161	99	166	97	129	

WESTERN - SAN BERNARDINO WATERMASTER

TABLE 1

VERIFIED EXTRACTIONS - FILED
SAN BERNARDINO BASIN AREA

RECRD TN NUMBER	STATE WELL NUMBER	WELL LOCAL TYPE DESIGNATION	FC	1959	1960	1961	1962	1963	AVG	2008	2009	2010	2011	2012	AVG
				-----BASE YEARS-----					-----CALENDAR YEAR EXTRACTIONS-----						
TOTAL VERIFIED PRODUCTION ALL FACILITIES 629 WELLS				177,350	162,142	167,784	161,557	144,712	162,709	188,254	168,673	159,525	163,889	173,867	170,842
TOTAL VERIFIED PRODUCTION ALL FACILITIES 25 ACRE-FEET PER YEAR OR LARGER										188,164	168,599	159,454	163,775	173,763	170,751

TABLE NO. 2

EXTRACTIONS BY OWNERS (NON-PLAINTIFFS) WHICH
HAVE NOT FILED WITH THE
STATE WATER RESOURCES CONTROL BOARD

WESTERN - SAN BERNARDINO WATERMASTER
TABLE 2

VERIFIED EXTRACTIONS - NON-FILED
SAN BERNARDINO BASIN AREA

RECRD TN NUMBER	STATE WELL NUMBER	WELL LOCAL TYPE DESIGNATION	FC	-----BASE YEARS-----										-----CALENDAR YEAR EXTRACTIONS-----															
				1959	1960	1961	1962	1963	AVG	2008	2009	2010	2011	2012	AVG														
AHMANSON RANCH																													
0000002	01S/04W-27H	W	<input checked="" type="checkbox"/>	200	200	200	200	200	200	200	200	200	200	200	200	0	0	0	0	0	0	0	0						
TOTALS FOR AHMANSON RANCH				200	200	200	200	200	200	200	200	200	200	200	200	200	0	0	0	0	0	0	0	0					
ANDERSON, W.D.																													
0000003	01N/04W-25R	W	<input checked="" type="checkbox"/>	0	0	0	0	0	0	0	0	0	0	0	0	0	0	0	0	0	0	0	0						
TOTALS FOR ANDERSON, W.D.				0	0	0	0	0	0	0	0	0	0	0	0	0	0	0	0	0	0	0	0	0					
ARNOLD RANCH																													
0000004	01N/03W-34H	W	<input checked="" type="checkbox"/>	230	230	230	230	230	230	230	230	230	230	230	230	0	0	0	0	0	0	0	0	0					
TOTALS FOR ARNOLD RANCH				230	230	230	230	230	230	230	230	230	230	230	230	230	0	0	0	0	0	0	0	0	0				
BALCOM,																													
0000005	01S/04W-11M	W	<input checked="" type="checkbox"/>	1	1	1	1	1	1	1	1	1	1	1	1	0	0	0	0	0	0	0	0	0					
TOTALS FOR BALCOM,				1	1	1	1	1	1	1	1	1	1	1	1	1	0	0	0	0	0	0	0	0	0				
BALDWIN,																													
0000006	01N/03W-34K	W	<input checked="" type="checkbox"/>	1	1	1	1	1	1	1	1	1	1	1	1	0	0	0	0	0	0	0	0	0					
TOTALS FOR BALDWIN,				1	1	1	1	1	1	1	1	1	1	1	1	1	0	0	0	0	0	0	0	0	0				
BARRIER,																													
0000007	01S/04W-22B	W	<input checked="" type="checkbox"/>	3	3	3	3	3	3	3	3	3	3	3	3	0	0	0	0	0	0	0	0	0					
TOTALS FOR BARRIER,				3	3	3	3	3	3	3	3	3	3	3	3	3	0	0	0	0	0	0	0	0	0				
BASELINE LAUNDRY																													
0000008	01N/03W-31Q	W	<input checked="" type="checkbox"/>	50	50	50	50	50	50	50	50	50	50	50	50	0	0	0	0	0	0	0	0	0					
0000082	01N/03W-31Q	W	<input checked="" type="checkbox"/>												0	0	0	0	0	0	0	0	0	0					
TOTALS FOR BASELINE LAUNDRY				50	50	50	50	50	50	50	50	50	50	50	50	50	0	0	0	0	0	0	0	0	0				
BATCHELOR,																													
0000009	01N/04W-14R	W	<input type="checkbox"/>	1	1	1	1	1	1	1	1	1	1	1	1	1	1	1	1	1	1	1	1	1					
0000010	01N/04W-14R	D	<input checked="" type="checkbox"/>	1	1	1	1	1	1	1	1	1	1	1	1	1	1	1	1	1	1	1	1	1					
TOTALS FOR BATCHELOR,				2	2	2	2	2	2	2	2	2	2	2	2	2	2	2	2	2	2	2	2	2	2				

WESTERN - SAN BERNARDINO WATERMASTER

TABLE 2

VERIFIED EXTRACTIONS - NON-FILED
SAN BERNARDINO BASIN AREA

RECRD TN NUMBER	STATE WELL NUMBER	WELL LOCAL TYPE DESIGNATION	FC	-----BASE YEARS-----							-----CALENDAR YEAR EXTRACTIONS-----					
				1959	1960	1961	1962	1963	AVG	2008	2009	2010	2011	2012	AVG	
BERMAN, BUD																
0000011	01S/04W-02K	W OLD WELL	<input checked="" type="checkbox"/>	120	110	130	0	0	0	72	0	0	0	0	0	
0000012	01S/04W-02J	W	<input checked="" type="checkbox"/>	84	84	84	84	84	84	84	0	0	0	0	0	
TOTALS FOR BERMAN, BUD				204	194	214	84	84	84	156	0	0	0	0	0	0
BLISS,																
0000013	01S/02W-22E	W	<input checked="" type="checkbox"/>	2	2	2	2	2	2	2	0	0	0	0	0	
TOTALS FOR BLISS,				2	2	2	2	2	2	2	0	0	0	0	0	0
BOUCHER,																
0000014	01N/04W-14J	W	<input checked="" type="checkbox"/>	1	1	1	1	1	1	1	1	1	1	1	0	
TOTALS FOR BOUCHER,				1	1	1	1	1	1	1	1	1	1	1	0	1
BREAK, ALLEN ESTATE																
0000015	01S/03W-31A	W	<input type="checkbox"/>	760	608	760	608	608	608	669	1	1	1	1	1	
TOTALS FOR BREAK, ALLEN ESTATE				760	608	760	608	608	608	669	1	1	1	1	1	1
CARPENTER,																
0000016	01S/04W-22B	W	<input checked="" type="checkbox"/>	4	4	4	4	4	4	4	0	0	0	0	0	
TOTALS FOR CARPENTER,				4	4	4	4	4	4	4	0	0	0	0	0	0
CLIFFSIDE RANCH																
0000017	01S/03W-03F	W	<input checked="" type="checkbox"/>	171	174	181	150	186	172	172	0	0	0	0	0	
TOTALS FOR CLIFFSIDE RANCH				171	174	181	150	186	172	172	0	0	0	0	0	0
COOK CANYON																
0000018	01N/03W-27R	D	<input type="checkbox"/>	35	35	35	35	35	35	35	0	0	0	0	0	
TOTALS FOR COOK CANYON				35	35	35	35	35	35	35	0	0	0	0	0	0
CRYSTAL SPRINGS																
0000020	02S/02W-06D	W	<input type="checkbox"/>	1	1	1	1	1	1	1	1	1	1	1	1	
TOTALS FOR CRYSTAL SPRINGS				1	1	1	1	1	1	1	1	1	1	1	1	1

WESTERN - SAN BERNARDINO WATERMASTER
TABLE 2

VERIFIED EXTRACTIONS - NON-FILED
SAN BERNARDINO BASIN AREA

RECRD TN NUMBER	STATE WELL NUMBER	WELL LOCAL TYPE DESIGNATION	FC	-----BASE YEARS-----											-----CALENDAR YEAR EXTRACTIONS-----			
				1959	1960	1961	1962	1963	AVG	2008	2009	2010	2011	2012	AVG			
DANGERMOND, JACK																		
0000078	01S/02W-28M	W LA TOURETTE	<input checked="" type="checkbox"/>	30	30	30	30	30	30	30	30	30	0	0	0	0	0	
0000079	01S/02W-28M	D SPRING DIV.	<input type="checkbox"/>	1	1	1	1	1	1	1	1	1	1	1	1	1	1	
TOTALS FOR DANGERMOND, JACK				31	31	31	31	31	31	31	31	31	1	1	1	1	1	1
DANIELS, DON																		
0000175	01S/03W-19J	W	<input checked="" type="checkbox"/>										0	0	0	0	0	
TOTALS FOR DANIELS, DON													0	0	0	0	0	
DANIELS, HAROLD																		
0000022	01S/03W-17R	W RANCH	<input checked="" type="checkbox"/>					500					100	0	0	0	0	
0000023	01S/03W-17C03S	W DOMESTIC WELL	<input checked="" type="checkbox"/>	2	2	2	2	2	2	2	2	2	2	0	0	0	0	
TOTALS FOR DANIELS, HAROLD				2	2	2	2	502	2	2	2	2	102	0	0	0	0	
DILLSON MUTUAL WATER COMPANY																		
0000025	01N/04W-24C	W DILLSON AVE	<input checked="" type="checkbox"/>	18	18	18	18	18	18	18	18	18	18	0	0	0	0	
0000026	01N/04W-13P	W HARRISON CYN	<input checked="" type="checkbox"/>	18	18	18	18	18	18	18	18	18	18	0	0	0	0	
0000173	01N/04W-24C	W CISCO WELL	<input type="checkbox"/>										0	0	0	0	0	
TOTALS FOR DILLSON MUTUAL WATER COMPANY				36	36	36	36	36	36	36	36	36	36	0	0	0	0	
DONGLO DAIRY																		
0000021	01S/04W-11F	W	<input checked="" type="checkbox"/>	35	35	35	35	35	35	35	35	35	35	0	0	0	0	
TOTALS FOR DONGLO DAIRY				35	35	35	35	35	35	35	35	35	35	0	0	0	0	
EAST HIGHLAND RANCH																		
0000028	01S/02W-06Q	D TUNNEL DIVERSION	<input type="checkbox"/>	1	1	1	1	1	1	1	1	1	1	0	0	0	0	
TOTALS FOR EAST HIGHLAND RANCH				1	1	1	1	1	1	1	1	1	1	0	0	0	0	
EAST HIGHLANDS ORANGE COMPANY																		
0000029	01N/03W-35B	D BOX SPRING	<input checked="" type="checkbox"/>	53	28	40	47	46	47	46	46	43	43	0	0	0	0	
TOTALS FOR EAST HIGHLANDS ORANGE COMPANY				53	28	40	47	46	47	46	43	43	0	0	0	0	0	
EAST VALLEY WATER DISTRICT																		
0000030	01N/03W-30C	W PLANT NO 36	<input checked="" type="checkbox"/>	0	0	0	0	0	0	0	0	0	0	0	0	0	0	

WESTERN - SAN BERNARDINO WATERMASTER

TABLE 2

VERIFIED EXTRACTIONS - NON-FILED
SAN BERNARDINO BASIN AREA

RECRD TN NUMBER	STATE WELL NUMBER	WELL LOCAL TYPE DESIGNATION	FC	-----BASE YEARS-----											-----CALENDAR YEAR EXTRACTIONS-----								
				1959	1960	1961	1962	1963	AVG	2008	2009	2010	2011	2012	AVG								
0000032	01S/03W-04P	W PLANT NO 43	<input checked="" type="checkbox"/>	24	24	29	30	20	25	0	0	0	0	0	0	0	0	0	0	0	0	0	
0000033	01S/03W-05R	W PLANT NO 44	<input checked="" type="checkbox"/>	50	51	56	38	34	46	0	0	0	0	0	0	0	0	0	0	0	0	0	
0000034	01N/03W-31A	W PLANT NO 45	<input checked="" type="checkbox"/>	216	110	75	0	0	80	0	0	0	0	0	0	0	0	0	0	0	0	0	
0000035	01S/03W-05Q	W PLANT NO 46	<input checked="" type="checkbox"/>	11	9	12	6	3	8	0	0	0	0	0	0	0	0	0	0	0	0	0	
0000036	01N/04W-36H	W PLANT NO 52	<input checked="" type="checkbox"/>	35	1	0	0	0	7	0	0	0	0	0	0	0	0	0	0	0	0	0	
0000037	01S/03W-06Q	W PLANT NO 69	<input checked="" type="checkbox"/>	0	0	0	0	0	0	0	0	0	0	0	0	0	0	0	0	0	0	0	
0000038	01N/03W-31D	W PLANT NO 70	<input checked="" type="checkbox"/>	39	55	2	2	0	20	0	0	0	0	0	0	0	0	0	0	0	0	0	
0000039	01S/03W-06E	W PLANT NO 71	<input checked="" type="checkbox"/>	35	35	35	0	0	21	0	0	0	0	0	0	0	0	0	0	0	0	0	
0000040	01S/03W-06B	W PLANT NO 72	<input checked="" type="checkbox"/>	10	10	10	10	10	10	0	0	0	0	0	0	0	0	0	0	0	0	0	
0000041	01S/03W-06C	W PLANT NO 74	<input checked="" type="checkbox"/>						0	0	0	0	0	0	0	0	0	0	0	0	0	0	
0000042	01S/04W-02L	W PLANT NO 75	<input checked="" type="checkbox"/>	20	20	20	20	20	20	0	0	0	0	0	0	0	0	0	0	0	0	0	
0000043	01S/03W-06P	W PLANT NO 78	<input checked="" type="checkbox"/>	4	4	4	4	4	3	0	0	0	0	0	0	0	0	0	0	0	0	0	
0000044	01S/03W-05Q	W PLANT NO 80	<input checked="" type="checkbox"/>	1	1	1	1	1	1	0	0	0	0	0	0	0	0	0	0	0	0	0	
0000045	01S/03W-06M	W PLANT NO 81	<input checked="" type="checkbox"/>	572	690	848	560	668	668	0	0	0	0	0	0	0	0	0	0	0	0	0	
0000046	01S/03W-06Q	W PLANT NO 83	<input checked="" type="checkbox"/>	27	21	23	25	27	25	0	0	0	0	0	0	0	0	0	0	0	0	0	
0000047	01S/03W-03N	W PLANT NO 84	<input checked="" type="checkbox"/>	10	10	10	10	10	10	0	0	0	0	0	0	0	0	0	0	0	0	0	
0000048	01N/04W-25D	W PLANT NO 85	<input checked="" type="checkbox"/>	11	11	11	11	11	11	0	0	0	0	0	0	0	0	0	0	0	0	0	
0000049	01S/03W-03N	W PLANT NO 93	<input checked="" type="checkbox"/>	5	5	5	5	5	3	0	0	0	0	0	0	0	0	0	0	0	0	0	
0000050	01S/03W-05J	W PLANT NO 95	<input checked="" type="checkbox"/>	2	2				1	0	0	0	0	0	0	0	0	0	0	0	0	0	
0000051	01S/04W-01D	W PLANT NO 96	<input checked="" type="checkbox"/>	20	20	20	20	20	20	0	0	0	0	0	0	0	0	0	0	0	0	0	
0000052	01S/03W-06N	W PLANT NO 97	<input checked="" type="checkbox"/>	150	99	137	373	190	190	0	0	0	0	0	0	0	0	0	0	0	0	0	
0000059	01S/03W-04Q	W PLANT NO 106	<input checked="" type="checkbox"/>	20	20	20	20	20	20	0	0	0	0	0	0	0	0	0	0	0	0	0	
0000076	01S/03W-06L	W LANKERSHIM A	<input checked="" type="checkbox"/>	100	100	100	100	100	100	0	0	0	0	0	0	0	0	0	0	0	0	0	
0000077	01S/03W-06F	W MCKINLEY ST.	<input checked="" type="checkbox"/>	50	50	50	50	50	50	0	0	0	0	0	0	0	0	0	0	0	0	0	
TOTALS FOR EAST VALLEY WATER DISTRICT				1,412	1,348	1,468	1,280	1,184	1,338	0	0	0	0	0	0	0	0	0	0	0	0	0	
ELLENA, JOHN B.																							
0000054	01N/04W-08N	W	<input checked="" type="checkbox"/>	585	585	585	585	585	585	0	0	0	0	0	0	0	0	0	0	0	0	0	
TOTALS FOR ELLENA, JOHN B.				585	585	585	585	585	585	0	0	0	0	0	0	0	0	0	0	0	0	0	0
ELLGOOD,																							
0000055	01S/02W-24C	W	<input type="checkbox"/>	5	5	5	5	5	5	0	0	0	0	0	0	0	0	0	0	0	0	0	

WESTERN - SAN BERNARDINO WATERMASTER
TABLE 2

VERIFIED EXTRACTIONS - NON-FILED
SAN BERNARDINO BASIN AREA

RECRD TN NUMBER	STATE WELL NUMBER	WELL LOCAL TYPE DESIGNATION	FC	-----BASE YEARS-----							-----CALENDAR YEAR EXTRACTIONS-----							
				1959	1960	1961	1962	1963	AVG	2008	2009	2010	2011	2012	AVG			
TOTALS FOR FALLOW,				5	5	5	5	5	5	5	5	0	0	0	0	0	0	
FALLOW,																		
0000056	01S/02W-22E	W	<input type="checkbox"/>	6	5	28	5	5	5	10	5	5	5	5	5	5	5	
TOTALS FOR FALLOW,				6	5	28	5	5	10	5	5	5	5	5	5	5	5	
FINCH,																		
0000057	01S/02W-29C	W	<input checked="" type="checkbox"/>						0	0	0	0	0	0	0	0	0	
TOTALS FOR FINCH,									0	0	0	0	0	0	0	0	0	
GOLCONDA WATER COMPANY																		
0000058	01S/04W-13E	W	<input checked="" type="checkbox"/>	96	96	96	96	96	96	96	0	0	0	0	0	0	0	
TOTALS FOR GOLCONDA WATER COMPANY				96	96	96	96	96	96	96	0	0	0	0	0	0	0	0
GREENSPOT MUTUAL WATER CO. TUNNEL																		
0000166	01S/02W-22C	D	<input type="checkbox"/>						0	0	50	50	50	50	50	50	50	
TOTALS FOR GREENSPOT MUTUAL WATER CO. TUNNEL									0	0	50	50	50	50	50	50	50	
HAGAR,																		
0000060	01S/02W-16L	W	<input checked="" type="checkbox"/>	1	1	1	1	1	1	1	0	0	0	0	0	0	0	
TOTALS FOR HAGAR,				1	1	1	1	1	1	1	0	0	0	0	0	0	0	0
HARDISON,																		
0000061	01N/04W-13Q	W	<input type="checkbox"/>	1	1	1	1	1	1	1	1	1	1	1	0	1	1	
TOTALS FOR HARDISON,				1	1	1	1	1	1	1	1	1	1	1	1	0	1	1
HARRISON CANYON																		
0000063	01N/04W-13N	W	<input checked="" type="checkbox"/>	1	1	1	1	1	1	1	0	0	0	0	0	0	0	
0000064	01N/04W-13N	W	<input type="checkbox"/>	1	1	1	1	1	1	1	0	0	0	0	0	1	0	
TOTALS FOR HARRISON CANYON				2	2	2	2	2	2	2	0	0	0	0	0	1	1	0
HARRISON,																		
0000062	01S/03W-04J01S	W	<input checked="" type="checkbox"/>	1	1	1	1	1	1	1	0	0	0	0	0	0	0	

WESTERN - SAN BERNARDINO WATERMASTER
TABLE 2

VERIFIED EXTRACTIONS - NON-FILED
SAN BERNARDINO BASIN AREA

RECRD TN NUMBER	STATE WELL NUMBER	WELL LOCAL TYPE DESIGNATION	FC	-----BASE YEARS-----								-----CALENDAR YEAR EXTRACTIONS-----					
				1959	1960	1961	1962	1963	AVG	2008	2009	2010	2011	2012	AVG		
TOTALS FOR HARRISON,				1	1	1	1	1	1	1	1	0	0	0	0	0	0
HAZAS,																	
0000065	01S/04W-11G	W	<input checked="" type="checkbox"/>	8	8	8	8	8	8	8	8	0	0	0	0	0	
TOTALS FOR HAZAS,				8	8	8	8	8	8	8	0	0	0	0	0	0	0
HELIPORT																	
0000066	01S/04W-15G	W	<input checked="" type="checkbox"/>	1	1	1	1	1	1	1	1	0	0	0	0	0	
TOTALS FOR HELIPORT				1	1	1	1	1	1	1	0	0	0	0	0	0	0
HILL,																	
0000067	01S/02W-31B	W	<input checked="" type="checkbox"/>									0	0	0	0	0	
TOTALS FOR HILL,												0	0	0	0	0	0
HOLDEN MUTUAL WATER COMPANY																	
0000068	01S/04W-14E	W	<input checked="" type="checkbox"/>	2	2	2	2	2	2	2	2	0	0	0	0	0	
0000069	01S/04W-14F	W	<input checked="" type="checkbox"/>	12	12	12	12	12	12	12	12	0	0	0	0	0	
TOTALS FOR HOLDEN MUTUAL WATER COMPANY				14	14	14	14	14	14	14	14	0	0	0	0	0	0
HORTON,																	
0000070	01S/03W-32J	W	<input type="checkbox"/>	385	300	420	364	357	364	357	365	248	315	267	222	356	
TOTALS FOR HORTON,				385	300	420	364	357	364	357	365	248	315	267	222	356	282
HUNTER,																	
0000071	01S/03W-03D	W	<input checked="" type="checkbox"/>	3	3	3	3	3	3	3	3	0	0	0	0	0	
TOTALS FOR HUNTER,				3	3	3	3	3	3	3	3	0	0	0	0	0	0
INLAND VALLEY DEVELOPMENT AGENCY																	
0000086	01S/04W-07D	W	<input checked="" type="checkbox"/>	688	619	640	699	623	699	623	654	0	0	0	0	0	
0000087	01S/04W-12C	W	<input checked="" type="checkbox"/>	473	425	440	480	429	480	429	449	0	0	0	0	0	
0000088	01S/04W-12D	W	<input checked="" type="checkbox"/>	860	773	800	874	780	874	780	817	0	0	0	0	0	
0000089	01S/04W-12F	W	<input checked="" type="checkbox"/>	1,721	1,546	1,599	1,747	1,559	1,747	1,559	1,634	0	0	0	0	0	
0000090	01S/03W-07A	W	<input checked="" type="checkbox"/>	946	850	879	961	857	961	857	899	0	0	0	0	0	
0000091	01S/04W-12Q	W	<input checked="" type="checkbox"/>	0	0	0	0	0	0	0	0	0	0	0	0	0	

WESTERN - SAN BERNARDINO WATERMASTER
TABLE 2

VERIFIED EXTRACTIONS - NON-FILED
SAN BERNARDINO BASIN AREA

RECRD TN NUMBER	STATE WELL NUMBER	WELL LOCAL TYPE DESIGNATION	FC	-----BASE YEARS-----							-----CALENDAR YEAR EXTRACTIONS-----					
				1959	1960	1961	1962	1963	AVG	2008	2009	2010	2011	2012	AVG	
0000092	01S/04W-12G	W LOCAL NO. 44	<input checked="" type="checkbox"/>	860	773	800	874	780	817	0	0	0	0	0	0	0
0000093	01S/03W-08E	W LOCAL NO.347	<input checked="" type="checkbox"/>	0	0	0	0	0	0	0	0	0	0	0	0	0
0000094	01S/03W-08M	W LOCAL NO.865	<input checked="" type="checkbox"/>	344	309	320	350	312	327	0	0	0	0	0	0	0
TOTALS FOR INLAND VALLEY DEVELOPMENT AGENCY				5,892	5,295	5,478	5,985	5,340	5,598	0	0	0	0	0	0	0
INTER CITY MUTUAL WATER COMPANY																
0000072	01S/04W-23P	W	<input checked="" type="checkbox"/>						0	0	0	0	0	0	0	0
TOTALS FOR INTER CITY MUTUAL WATER COMPANY				0	0	0	0	0	0	0	0	0	0	0	0	0
KING,																
0000073	01N/04W-14R	W	<input type="checkbox"/>	1	1	1	1	1	1	1	1	1	1	1	1	1
TOTALS FOR KING,				1	1	1	1	1	1	1	1	1	1	1	1	1
KOCH,																
0000074	01S/02W-32B	W	<input checked="" type="checkbox"/>						0	0	0	0	0	0	0	0
TOTALS FOR KOCH,				0	0	0	0	0	0	0	0	0	0	0	0	0
KRANTZ DAIRY																
0000075	01S/04W-11F	W	<input checked="" type="checkbox"/>	100	100	100	100	100	100	0	0	0	0	0	0	0
TOTALS FOR KRANTZ DAIRY				100	100	100	100	100	100	0	0	0	0	0	0	0
KUHN, RICHARD J.																
0000178	01S/03W-32G	W	<input type="checkbox"/>						0	0	0	0	0	0	0	0
TOTALS FOR KUHN, RICHARD J.				0	0	0	0	0	0	0	0	0	0	0	0	0
L. P. R. RANCH																
0000080	01S/03W-13C	W	<input checked="" type="checkbox"/>	485	660	610	610	351	351	0	0	0	0	0	0	0
TOTALS FOR L. P. R. RANCH				485	660	610	610	0	0	0	0	0	0	0	0	0
MARSHBURN,																
0000081	01S/03W-17G	W	<input type="checkbox"/>	380	300	290	290	194	194	100	100	100	100	100	100	100
TOTALS FOR MARSHBURN,				380	300	290	290	0	0	100	100	100	100	100	100	100

WESTERN - SAN BERNARDINO WATERMASTER
TABLE 2

VERIFIED EXTRACTIONS - NON-FILED
SAN BERNARDINO BASIN AREA

RECRD TN NUMBER	STATE WELL NUMBER	WELL LOCAL TYPE DESIGNATION	FC	-----BASE YEARS-----							-----CALENDAR YEAR EXTRACTIONS-----					
				1959	1960	1961	1962	1963	AVG	2008	2009	2010	2011	2012	AVG	
MCCALLA BROS.																
0000164	01S/03W-20Q	W	<input checked="" type="checkbox"/>	1	1	1	1	1	1	1	0	0	0	0	0	0
TOTALS FOR MCCALLA BROS.																
MENTONE DOMESTIC WATER COMPANY																
0000083	01S/02W-19J	W	<input checked="" type="checkbox"/>	25							5	0	0	0	0	0
0000176	01S/02W-19J	W 3 1971	<input checked="" type="checkbox"/>								0	0	0	0	0	0
TOTALS FOR MENTONE DOMESTIC WATER COMPANY																
MOORE, R. H.																
0000084	01S/04W-24K	W	<input checked="" type="checkbox"/>	46	42	89	78	77	77	66	66	0	0	0	0	0
TOTALS FOR MOORE, R. H.																
MT. VIEW CHILD CARE CENTER																
0000145	01S/04W-24J	W	<input checked="" type="checkbox"/>	2	2	2	2	2	2	2	2	0	0	0	0	0
TOTALS FOR MT. VIEW CHILD CARE CENTER																
NO NAME WELL																
0000085	01N/03W-32M	W	<input checked="" type="checkbox"/>	30	27	32	28	28	28	29	29	0	0	0	0	0
TOTALS FOR NO NAME WELL																
NORWOOD,																
0000095	01N/03W-34F	W	<input checked="" type="checkbox"/>	1	1	1	1	1	1	1	1	0	0	0	0	0
TOTALS FOR NORWOOD,																
PACIFIC HIGH SCHOOL																
0000096	01N/04W-35H	W	<input checked="" type="checkbox"/>	75	75	75	75	75	75	75	75	0	0	0	0	0
TOTALS FOR PACIFIC HIGH SCHOOL																
PATTERSON, ROY H.																
0000163	01N/03W-34Q	W	<input checked="" type="checkbox"/>								0	0	0	0	0	0
TOTALS FOR PATTERSON, ROY H.																

WESTERN - SAN BERNARDINO WATERMASTER
TABLE 2

VERIFIED EXTRACTIONS - NON-FILED
SAN BERNARDINO BASIN AREA

RECRD TN NUMBER	STATE WELL NUMBER	WELL LOCAL TYPE DESIGNATION	FC	-----BASE YEARS-----							-----CALENDAR YEAR EXTRACTIONS-----									
				1959	1960	1961	1962	1963	1963	AVG	2008	2009	2010	2011	2012	AVG				
PIERSON,																				
0000097	01N/04W-35N	W	<input checked="" type="checkbox"/>	80	80	80	80	80	80	80	80	64	0	0	0	0	0	0	0	
TOTALS FOR PIERSON,				80	80	80	80	80	80	80	64	0	0	0	0	0	0	0	0	0
QUALITY FARMS																				
0000053	01S/03W-04R	W NO. 102	<input checked="" type="checkbox"/>	123	123	123	123	123	123	123	123	123	0	0	0	0	0	0	0	
TOTALS FOR QUALITY FARMS				123	123	123	123	123	123	123	123	123	0	0	0	0	0	0	0	0
RAMSEY,																				
0000098	01S/02W-22F	D SPRING DIV	<input checked="" type="checkbox"/>	1	1	1	1	1	1	1	1	1	0	0	0	0	0	0	0	
TOTALS FOR RAMSEY,				1	1	1	1	1	1	1	1	1	0	0	0	0	0	0	0	0
REDLANDS ASSOCIATES																				
0000099	01S/02W-17B	W #0	<input checked="" type="checkbox"/>							13		3	0	0	0	0	0	0	0	
0000100	01S/02W-09P	W BLOCK NO. 6	<input checked="" type="checkbox"/>	200	162	200	169	166	166	179	179	179	0	0	0	0	0	0	0	
0000101	01S/02W-09L	W BLOCK NO. 11	<input checked="" type="checkbox"/>	145	119	146	123	122	122	131	131	131	0	0	0	0	0	0	0	
0000102	01S/02W-09L	D TUNNEL DIV.	<input checked="" type="checkbox"/>	144	97	92	122	110	110	113	113	113	0	0	0	0	0	0	0	
TOTALS FOR REDLANDS ASSOCIATES				489	378	438	414	411	411	426	426	426	0	0	0	0	0	0	0	0
REDLANDS WATER COMPANY																				
0000104	01S/02W-08A	D REDLANDS WATER C	<input type="checkbox"/>	544	599	301	754	581	581	556	556	556	625	654	629	739	529	529	635	
TOTALS FOR REDLANDS WATER COMPANY				544	599	301	754	581	581	556	556	556	625	654	629	739	529	529	635	635
REDLANDS, CITY OF																				
0000103	01S/02W-13B	D MILL CREEK DIV	<input checked="" type="checkbox"/>	10	10	10	10	10	10	10	10	10	0	0	0	0	0	0	0	
TOTALS FOR REDLANDS, CITY OF				10	10	10	10	10	10	10	10	10	0	0	0	0	0	0	0	0
REGINA GRAPE PRODUCTS																				
0000105	01N/05W-04M	W WELL NO. 1	<input checked="" type="checkbox"/>	60	60	60	60	60	60	60	60	60	0	0	0	0	0	0	0	
0000106	01N/05W-04N	W WELL NO. 2	<input checked="" type="checkbox"/>	24	24	24	24	24	24	24	24	24	0	0	0	0	0	0	0	
0000107	01N/05W-04N	W WELL NO. 3	<input checked="" type="checkbox"/>	27	27	27	27	27	27	27	27	27	0	0	0	0	0	0	0	
0000108	01N/05W-05C	D SPRING DIV.	<input checked="" type="checkbox"/>	29	29	29	29	29	29	29	29	29	0	0	0	0	0	0	0	
0000109	01N/05W-05R	W WELL NO. 4	<input checked="" type="checkbox"/>	33	33	33	33	33	33	33	33	33	0	0	0	0	0	0	0	
0000110	01N/05W-04N	W WELL NO. 5	<input checked="" type="checkbox"/>	24	24	24	24	24	24	24	24	24	0	0	0	0	0	0	0	

WESTERN - SAN BERNARDINO WATERMASTER
TABLE 2

VERIFIED EXTRACTIONS - NON-FILED
SAN BERNARDINO BASIN AREA

RECRD TN NUMBER	STATE WELL NUMBER	WELL LOCAL TYPE DESIGNATION	FC	-----BASE YEARS-----											-----CALENDAR YEAR EXTRACTIONS-----							
				1959	1960	1961	1962	1963	AVG	2008	2009	2010	2011	2012	AVG							
0000111	01N/05W-04N	W WELL NO. 6	<input checked="" type="checkbox"/>	33	33	33	33	33	33	33	33	33	33	33	0	0	0	0	0	0	0	
0000112	01N/05W-04N	W WELL NO. 7	<input checked="" type="checkbox"/>	20	20	20	20	20	20	20	20	20	20	20	0	0	0	0	0	0	0	
TOTALS FOR REGINA GRAPE PRODUCTS				250	250	250	250	250	250	250	250	250	250	250	0	0	0	0	0	0	0	
RIVAS,																						
0000113	01S/04W-24J	W	<input checked="" type="checkbox"/>	1	1	1	1	1	1	1	1	1	1	1	0	0	0	0	0	0	0	
TOTALS FOR RIVAS,				1	1	1	1	1	1	1	1	1	1	1	0	0	0	0	0	0	0	0
RULE,																						
0000114	01N/03W-34K	W SPRING	<input checked="" type="checkbox"/>	1	1	1	1	1	1	1	1	1	1	1	0	0	0	0	0	0	0	
TOTALS FOR RULE,				1	1	1	1	1	1	1	1	1	1	1	0	0	0	0	0	0	0	0
SAN BERNARDINO COUNTY - FACILITY MANAGEMENT																						
0000001	01S/04W-14A	W AEROSPACE	<input checked="" type="checkbox"/>	145	145	145	80	80	80	80	80	119	119	119	0	0	0	0	0	0	0	
TOTALS FOR SAN BERNARDINO COUNTY - FACILITY MANAGE				145	145	145	80	80	80	80	119	119	119	119	0	0	0	0	0	0	0	0
SAN BERNARDINO, CITY OF																						
0000015	01S/04W-21A	W SEWER PLANT 1	<input checked="" type="checkbox"/>	3	3	3	3	3	3	3	3	3	3	3	0	0	0	0	0	0	0	
0000016	01S/04W-22C	W SEWER PLANT 2	<input checked="" type="checkbox"/>	5	5	5	5	5	5	5	5	5	5	5	0	0	0	0	0	0	0	
TOTALS FOR SAN BERNARDINO, CITY OF				8	8	8	8	8	8	8	8	8	8	8	0	0	0	0	0	0	0	0
SAN MANUEL INDIAN RESERVATION																						
0000119	01N/03W-20N	W	<input type="checkbox"/>	6	6	6	6	6	6	6	6	6	6	6	0	0	0	0	0	0	0	
0000160	01N/03W-19R	W DOMESTIC	<input type="checkbox"/>	1	1	1	1	1	1	1	1	1	1	1	1	1	1	1	1	1	1	
0000161	01N/03W-19R	W	<input type="checkbox"/>	28	28	28	28	28	28	28	28	28	28	28	15	15	15	15	15	15	15	
0000162	01N/03W-19R	D YORK TUNNEL	<input type="checkbox"/>	30	26	20	30	28	28	30	28	27	27	27	0	0	0	0	0	0	0	
TOTALS FOR SAN MANUEL INDIAN RESERVATION				65	61	55	65	63	63	62	62	62	62	62	16	16	16	16	16	16	16	16
SANDY'S RESTAURANT																						
0000165	01S/03W-21M02S	W	<input checked="" type="checkbox"/>												0	0	0	0	0	0	0	
TOTALS FOR SANDY'S RESTAURANT															0	0	0	0	0	0	0	0
SANTINI,																						
0000120	01S/04W-14A	W	<input checked="" type="checkbox"/>	90	90	90	90	90	90	90	90	90	90	90	0	0	0	0	0	0	0	

WESTERN - SAN BERNARDINO WATERMASTER

TABLE 2

VERIFIED EXTRACTIONS - NON-FILED
SAN BERNARDINO BASIN AREA

RECRD TN NUMBER	STATE WELL NUMBER	WELL LOCAL TYPE DESIGNATION	FC	-----BASE YEARS-----							-----CALENDAR YEAR EXTRACTIONS-----															
				1959 90	1960 90	1961 90	1962 90	1963 90	AVG 90	2008	2009	2010	2011	2012	AVG											
TOTALS FOR SANTINI,														0	0	0	0	0	0	0	0	0	0	0	0	0
SATOSKI,																										
0000121	01N/04W-14J	W	<input type="checkbox"/>	1	1	1	1	1	1	1	1	1	1	1	1	1	1	1	1							
TOTALS FOR SATOSKI,														1	1	1	1	1	1	1	1	1	1	1	1	1
SELEY,																										
0000122	01N/03W-19Q	D TUNNEL DIV.	<input checked="" type="checkbox"/>	1	1	1	1	1	1	1	1	0	0	0	0	0	0	0	0							
TOTALS FOR SELEY,														1	1	1	1	1	1	0	0	0	0	0	0	0
SIX HOUSES																										
0000123	01S/04W-22A	W	<input checked="" type="checkbox"/>	6	6	6	6	6	6	6	6	0	0	0	0	0	0	0	0							
TOTALS FOR SIX HOUSES														6	6	6	6	6	6	0	0	0	0	0	0	0
SMITH MEAT PACKING PLANT																										
0000126	01S/04W-22M01S	W	<input checked="" type="checkbox"/>	3	3	3	3	3	3	3	3	0	0	0	0	0	0	0	0							
TOTALS FOR SMITH MEAT PACKING PLANT														3	3	3	3	3	3	0	0	0	0	0	0	0
SMITH,																										
0000124	01N/04W-14J	W	<input type="checkbox"/>	1	1	1	1	1	1	1	1	1	1	1	1	1	1	1	1							
0000125	01S/03W-02J	W	<input type="checkbox"/>	10	10	10	10	10	10	10	10	10	20	20	20	7	37	19								
TOTALS FOR SMITH,														11	11	11	11	11	11	11	21	21	21	8	38	20
STANLEY, SILAS																										
0000127	01S/02W-24H	W	<input checked="" type="checkbox"/>	2	2	2	2	2	2	2	2	0	0	0	0	0	0	0	0							
TOTALS FOR STANLEY, SILAS														2	2	2	2	2	2	0	0	0	0	0	0	0
STEWART, WILLARD																										
0000128	01S/03W-31D	W	<input checked="" type="checkbox"/>	53	53	53	53	53	53	53	53	0	0	0	0	0	0	0	0							
TOTALS FOR STEWART, WILLARD														53	53	53	53	53	53	0	0	0	0	0	0	0
STRAWBERRY PATCH																										
0000129	01S/03W-03N	W	<input checked="" type="checkbox"/>									0	0	0	0	0	0	0	0							
0000130	01S/03W-03N	W	<input checked="" type="checkbox"/>	1	1	1	1	1	1	1	1	0	0	0	0	0	0	0	0							

WESTERN - SAN BERNARDINO WATERMASTER
TABLE 2

VERIFIED EXTRACTIONS - NON-FILED
SAN BERNARDINO BASIN AREA

RECRD TN NUMBER	STATE WELL NUMBER	WELL LOCAL TYPE DESIGNATION	FC	-----BASE YEARS-----							-----CALENDAR YEAR EXTRACTIONS-----								
				1959	1960	1961	1962	1963	AVG	2008	2009	2010	2011	2012	AVG				
TOTALS FOR STRAWBERRY PATCH				1	1	1	1	1	1	1	1	0	0	0	0	0	0		
SUPERIOR ORCHARDS																			
0000131	01N/03W-29B	D TUNNEL DIV.	<input checked="" type="checkbox"/>	1	1	1	1	1	1	1	1	0	0	0	0	0	0		
TOTALS FOR SUPERIOR ORCHARDS				1	1	1	1	1	1	1	1	0	0	0	0	0	0	0	
TEXACO GAS STATION																			
0000027	01S/04W-24J	W	<input checked="" type="checkbox"/>									0	0	0	0	0	0		
TOTALS FOR TEXACO GAS STATION												0	0	0	0	0	0	0	
THOMPSON, RANDALL																			
00000132	01N/03W-28A	D SPRING DIV.	<input checked="" type="checkbox"/>	3	3	3	3	3	3	3	3	0	0	0	0	0	0	0	
TOTALS FOR THOMPSON, RANDALL				3	3	3	3	3	3	3	3	0	0	0	0	0	0	0	0
TRI-CITY MUTUAL WATER COMPANY																			
00000133	01S/04W-23N	W	<input checked="" type="checkbox"/>	0	0	0	0	0	0	0	0	0	0	0	0	0	0	0	
TOTALS FOR TRI-CITY MUTUAL WATER COMPANY				0	0	0	0	0	0	0	0	0	0	0	0	0	0	0	0
TRIPLE FALLS MUTUAL WATER COMPANY																			
00000134	01S/01W-19G	W	<input checked="" type="checkbox"/>									0	0	0	0	0	0	0	
00000135	01S/01W-20D	W	<input checked="" type="checkbox"/>	5	5	4	5	5	5	5	5	0	0	0	0	0	0	0	
00000136	01S/01W-20D	W	<input checked="" type="checkbox"/>	10	7	6	10	13	9	9	9	0	0	0	0	0	0	0	
TOTALS FOR TRIPLE FALLS MUTUAL WATER COMPANY				15	12	10	15	18	14	14	14	0	0	0	0	0	0	0	0
U. S. FOREST SERVICE																			
00000137	01N/04W-13Q	W MAINT. YARD	<input checked="" type="checkbox"/>	9	9	9	9	9	9	9	9	0	0	0	0	0	0	0	
00000138	01S/02W-13P	W MILL CREEK	<input checked="" type="checkbox"/>									0	0	0	0	0	0	0	
TOTALS FOR U. S. FOREST SERVICE				9	9	9	9	9	9	9	9	0	0	0	0	0	0	0	0
UNIVERSITY OF REDLANDS																			
00000139	01S/02W-17A	W PEPPER HOUSE	<input type="checkbox"/>									0	5	5	5	5	10	6	
TOTALS FOR UNIVERSITY OF REDLANDS												0	5	5	5	5	10	6	6

WESTERN - SAN BERNARDINO WATERMASTER
TABLE 2

VERIFIED EXTRACTIONS - NON-FILED
SAN BERNARDINO BASIN AREA

RECRD TN NUMBER	STATE WELL NUMBER	WELL LOCAL TYPE DESIGNATION	FC	-----BASE YEARS-----							-----CALENDAR YEAR EXTRACTIONS-----							
				1959	1960	1961	1962	1963	AVG	2008	2009	2010	2011	2012	AVG			
UNKNOWN	01S/04W-14F	W FOISTY STREET	<input checked="" type="checkbox"/>							0	0	0	0	0	0	0	0	
TOTALS FOR UNKNOWN										0	0	0	0	0	0	0	0	
VALENCIA AVE. MUTUAL WATER COMPANY																		
0000140	01N/04W-23K	W WATERMAN AVE	<input checked="" type="checkbox"/>	30	30	30	30	30	30	30	30	0	0	0	0	0	0	
TOTALS FOR VALENCIA AVE. MUTUAL WATER COMPANY				30	30	30	30	30	30	30	30	0	0	0	0	0	0	0
VALLEY FARMS MUTUAL WATER COMPANY																		
0000141	01S/04W-15R	W NO 1 WASHTN	<input checked="" type="checkbox"/>	90	90	90	90	90	90	90	90	0	0	0	0	0	0	
0000142	01S/04W-15Q	W NO 2 WELL	<input checked="" type="checkbox"/>	29	29	29	29	29	29	29	29	0	0	0	0	0	0	
TOTALS FOR VALLEY FARMS MUTUAL WATER COMPANY				119	119	119	119	119	119	119	119	0	0	0	0	0	0	0
VAN MEETER,																		
0000146	01S/03W-02P	W OLD WELL	<input checked="" type="checkbox"/>	3	3	0	0	0	0	0	1	0	0	0	0	0	0	
0000147	01S/03W-02P	W NEW WELL	<input checked="" type="checkbox"/>								0	0	0	0	0	0	0	
TOTALS FOR VAN MEETER,				3	3	0	0	0	0	1	0	0	0	0	0	0	0	0
VANLEUVEN, CLARENCE																		
0000143	01S/04W-24J	W	<input checked="" type="checkbox"/>	26	26	26	26	26	26	26	26	0	0	0	0	0	0	
TOTALS FOR VANLEUVEN, CLARENCE				26	26	26	26	26	26	26	26	0	0	0	0	0	0	0
VICTORIA SEVENTH DAY ADVENTIST																		
0000144	01S/04W-24J	W	<input type="checkbox"/>	15	15	15	15	15	15	15	15	10	10	10	10	10	10	
TOTALS FOR VICTORIA SEVENTH DAY ADVENTIST				15	15	15	15	15	15	15	15	10	10	10	10	10	10	10
WALLACE,																		
0000148	01N/04W-14J	W	<input checked="" type="checkbox"/>	1	1	1	1	1	1	1	1	1	1	1	1	0	1	
TOTALS FOR WALLACE,				1	1	1	1	1	1	1	1	1	1	1	1	1	0	1
WARD, FLOYD																		
0000149	01S/01W-18N	W WELL NO. 1	<input type="checkbox"/>				16	16	16	6	0	0	0	0	1	0	0	
0000150	01S/01W-18P	W WELL NO. 2	<input type="checkbox"/>				17	17	17	7	0	0	0	0	10	2	2	
0000151	01S/01W-18P	W WELL NO. 3	<input type="checkbox"/>	1	1	1	1	1	1	1	1	1	1	1	1	1	1	

WESTERN - SAN BERNARDINO WATERMASTER
TABLE 2

VERIFIED EXTRACTIONS - NON-FILED
SAN BERNARDINO BASIN AREA

RECRD TN NUMBER	STATE WELL NUMBER	WELL LOCAL TYPE DESIGNATION	FC	-----BASE YEARS-----										-----CALENDAR YEAR EXTRACTIONS-----						
				1959	1960	1961	1962	1963	AVG	2008	2009	2010	2011	2012	AVG					
0000152	01S/01W-18N	W WELL NO. 4	<input type="checkbox"/>				16	16				6	0	0	0	0	0	1	0	
0000153	01S/01W-18M	W WELL NO. 6	<input checked="" type="checkbox"/>				52	52				21	0	0	0	0	0	0	0	
0000154	01S/01W-18P	D LATERAL SPR S	<input checked="" type="checkbox"/>				1	1				0	0	0	0	0	0	0	0	
TOTALS FOR WARD, FLOYD				1	1	1	103	103				42	1	1	1	1	0	13	3	
WESTERN FRUIT GROWERS																				
0000156	01S/03W-24Q	W	<input checked="" type="checkbox"/>	147	220	177	0	0				109	0	0	0	0	0	0	0	
TOTALS FOR WESTERN FRUIT GROWERS				147	220	177	0	0				109	0	0	0	0	0	0	0	0
WIDEMEYER,																				
0000157	01N/03W-29H	D SPRING DIV.	<input checked="" type="checkbox"/>	1	1	1	1	1				1	0	0	0	0	0	0	0	
0000158	01N/03W-29H	W	<input checked="" type="checkbox"/>	5	5	5	5	5				5	0	0	0	0	0	0	0	
TOTALS FOR WIDEMEYER,				6	6	6	6	6				6	0	0	0	0	0	0	0	0
WILLIAMS DAIRY																				
0000159	01S/04W-11G	W	<input checked="" type="checkbox"/>	142	142	142	142	142				142	0	0	0	0	0	0	0	
TOTALS FOR WILLIAMS DAIRY				142	142	142	142	142				142	0	0	0	0	0	0	0	0
TOTALS FOR 165 WELLS				12,893	11,965	13,253	13,546	13,017				12,935	1,081	1,187	1,114	1,164	1,135	1,136	1,136	

TOTAL VERIFIED
PRODUCTION ALL
FACILITIES 25
ACRE-FEET PER
YEAR OR LARGER

1,023 1,119 1,046 1,111 1,073 1,074

TABLE NO. 3

SUMMARY OF EXTRACTIONS (FILED AND NON-FILED)
FROM SAN BERNARDINO BASIN AREA BY NON PLAINTIFFS
FOR USE WITHIN SAN BERNARDINO COUNTY

WESTERN - SAN BERNARDINO WATERMASTER
 TABLE 3 VERIFIED EXTRACTION SUMMARY
 VERIFIED EXTRACTIONS - FILED AND NON FILED

	-----BASE YEARS-----							-----CALENDAR YEAR EXTRACTIONS-----						
	1959	1960	1961	1962	1963	AVG	2008	2009	2010	2011	2012	AVG		
7TH AVE WELL	230	342	514	161	271	304	0	0	0	0	0	0		
AHMANSON RANCH	200	200	200	200	200	200	0	0	0	0	0	0		
ANDERSON, W.D.	0	0	0	0	0	0	0	0	0	0	0	0		
ARMSTRONG, DOUGLAS	286	342				126	0	0	0	0	0	0		
ARNOLD RANCH	230	230	230	230	230	230	0	0	0	0	0	0		
ARROWHEAD COUNTRY CLUB	600	607	650	650	650	631	531	472	396	385	433	443		
ARROYO VERDE MUTUAL WATER COMPANY	166	186	162	168	141	165	0	0	0	0	0	0		
ATCHISON TOPEKA & SANTA FE RAILWAY	316	254	226	220	138	231	0	0	0	0	0	0		
B M I FUNDS	343	323	165	165		199	0	0	0	0	0	0		
BBALCOM,	1	1	1	1	1	1	0	0	0	0	0	0		
BALDWIN,	1	1	1	1	1	1	0	0	0	0	0	0		
BARNO, JOHN					34	7	0	0	0	0	0	0		
BARRIER,	3	3	3	3	3	3	0	0	0	0	0	0		
BARTON DEVELOPMENT	1,133	1,622	1,145	300	475	935	0	0	0	0	0	0		
BARTON DEVELOPMENT C/O LUCKY FARMS	182	173	116	66	57	119	635	495	604	588	444	553		
BASE LINE WELL COMPANY	0	0	0	0	0	0	0	0	0	0	0	0		
BASELINE GARDENS MUTUAL WATER COMPANY	303	303	303	303	303	303	424	336	217	0	0	195		
BASELINE LAUNDRY	50	50	50	50	50	50	0	0	0	0	0	0		
BATCHELOR,	2	2	2	2	2	2	2	2	2	2	1	2		
BEAR VALLEY MUTUAL WATER COMPANY	22,886	19,239	16,209	17,467	14,266	18,013	13,701	10,368	17,524	16,862	15,560	14,803		
BELL, EUGENE	115	88	30	85	167	97	108	139	73	20	1	68		
BERMAN, BUD	204	194	214	112	116	168	5	0	0	0	0	1		
BLISS,	2	2	2	2	2	2	0	0	0	0	0	0		
BLUE BANNER COMPANY						0	100	100	100	100	50	90		
BLUE GOOSE GROWERS INC						0	0	0	0	0	0	0		
BOUCHER,	1	1	1	1	1	1	1	1	1	1	0	1		
BREAK, ALLEN ESTATE	760	608	760	608	608	669	1	1	1	1	1	1		
BRISTOL RANCH	90	100	160	108	108	113	0	0	0	0	0	0		

WESTERN - SAN BERNARDINO WATERMASTER
 TABLE 3 VERIFIED EXTRACTION SUMMARY
 VERIFIED EXTRACTIONS - FILED AND NON FILED

	-----BASE YEARS-----							-----CALENDAR YEAR EXTRACTIONS-----						
	1959	1960	1961	1962	1963	AVG	2008	2009	2010	2011	2012	AVG		
BROOKSIDE DAIRY INC	302	302	312	312	313	308	0	0	0	0	0	0		
BROOKSIDE PLAZA						0	14	14	13	7	13	12		
BUOYE WELL	0	0	146	160	177	97	0	0	0	0	0	0		
CALIF DEPT OF MENTAL HEALTH- PLANT OPERATIONS	947	1,076	1,085	1,003	957	1,014	198	53	1	5	11	54		
CALIFORNIA STATE UNIVERSITY, SAN BERNARDINO						0	208	185	162	165	185	181		
CALVARY CHAPEL SCHOOL						0	10	10	10	85	85	40		
CAMPUS CRUSADE FOR CHRIST	746	646	598	568	407	593	43	40	40	40	40	41		
CANYON RANCH	200	200	200	200	200	200	0	0	0	0	0	0		
CARDIFF FARMS MUTUAL WATER COMPANY	518	455	502	403	446	465	0	0	0	0	0	0		
CARPENTER,	4	4	4	4	4	4	0	0	0	0	0	0		
CARTER, JAMES	25	25	25	27	8	22	0	0	0	0	0	0		
CEMEX CONSTRUCTION MATERIALS PACIFIC, LLC	221	225	220	293	295	251	311	253	186	174	184	222		
CHARLES, J. J.	0	0	0	0	0	0	0	0	0	0	0	0		
CITY CREEK WATER COMPANY	123	51	7	64	30	55	0	0	0	0	0	0		
CLIFFSIDE RANCH	171	174	181	150	186	172	0	0	0	0	0	0		
COGBILL, CLINTON L.	312	296	325	181	91	241	50	50	50	50	50	50		
COLTON, CITY OF	2,814	3,606	3,305	3,743	3,267	3,347	6,917	6,334	4,740	4,783	6,222	5,799		
CONEJO RANCHOS MUTUAL WATER COMPANY	0	0	0	0	0	0	0	0	0	0	0	0		
COOK CANYON	35	35	35	35	35	35	0	0	0	0	0	0		
CRAFTON WATER COMPANY	787	949	1,205	901	825	933	684	530	99	10	14	267		
CRAM-PATTERSON WELL	413	257	361	277	294	320	531	596	415	415	534	498		
CRYSTAL SPRINGS	1	1	1	1	1	1	1	1	1	1	1	1		
DANGERMOND, JACK	193	179	362	237	344	263	216	334	1	1	1	111		
DANIELS RANCH						0	0	0	0	0	0	0		
DANIELS, DON						0	0	0	0	0	0	0		
DANIELS, HAROLD	2	2	2	2	502	102	0	0	0	0	0	0		
DEER PARK LLC	104	85	105	88	87	94	0	0	0	0	0	0		
DEL ROSA MUTUAL WATER COMPANY	325	300	570	529	284	402	0	0	0	0	0	0		

WESTERN - SAN BERNARDINO WATERMASTER
 TABLE 3 VERIFIED EXTRACTION SUMMARY
 VERIFIED EXTRACTIONS - FILED AND NON FILED

	-----BASE YEARS-----										-----CALENDAR YEAR EXTRACTIONS-----									
	1959	1960	1961	1962	1963	AVG	2008	2009	2010	2011	2012	AVG	2008	2009	2010	2011	2012	AVG		
DEVORE WATER COMPANY	126	129	140	132	136	133	606	542	570	580	535	567								
DILLSON MUTUAL WATER COMPANY	36	36	36	36	36	36	0	0	0	0	0	0	0	0	0	0	0	0		
DONGLO DAIRY	35	35	35	35	35	35	0	0	0	0	0	0	0	0	0	0	0	0		
DUCKWORTH, JOHN E.	252	243	353	250	244	268	1	0	0	0	0	0	0	0	0	0	0	0		
EAST BARTON WATER COMPANY	168	127	135	274	145	170	0	0	0	0	0	0	0	0	0	0	0	0		
EAST HIGHLAND RANCH	3,279	2,862	2,691	3,087	2,744	2,933	0	0	0	0	0	0	0	0	0	0	0	0		
EAST HIGHLANDS ORANGE COMPANY	53	28	40	47	46	43	0	0	0	0	0	0	0	0	0	0	0	0		
EAST PIONEER MUTUAL WELL COMPANY	776	692	876	403	431	636	0	0	0	0	0	0	0	0	0	0	0	0		
EAST VALLEY WATER DISTRICT	12,956	13,340	15,549	14,803	14,441	14,218	20,587	19,421	18,120	18,408	19,538	19,215								
EASTWOOD FARMS COMMUNITY WATER USERS	200	230	330	210	250	244	0	0	0	0	0	0	0	0	0	0	0	0		
ELLENA, JOHN B.	585	585	585	585	585	585	0	0	0	0	0	0	0	0	0	0	0	0		
ELLGOOD,	5	5	5	5	5	5	0	0	0	0	0	0	0	0	0	0	0	0		
ELTINGE & GRAZIADIO	122	81	64	49	32	70	0	0	0	0	0	0	0	0	0	0	0	0		
FAIRVIEW WATER COMPANY	1,395	875	825	780	575	890	266	286	102	80	71	161								
FAR WELL				272	264	107	74	70	29	0	0	35								
FARROW,	6	5	28	5	5	10	5	5	5	5	5	5								
FINCH,						0	0	0	0	0	0	0								
FONTANA UNION WATER COMPANY	19,841	15,649	13,295	14,674	12,086	15,109	10,523	7,789	7,074	9,574	12,605	9,513								
FRIEDEMANN, ERNEST C.	90	85	75	50	50	70	0	0	0	0	0	0	0	0	0	0	0	0		
FRINK RANCH	0	0	0	0	0	0	0	0	0	0	0	0	0	0	0	0	0	0		
GAY GROVE	200	200	260	250	200	222	40	55	39	32	38	41								
GENERAL AMERICAN LIFE	507	493	300	285	280	373	62	62	62	62	62	62								
GLADYSTA WELL & WATER COMPANY	527	486	609	517	507	529	51	65	88	99	143	89								
GOLCONDA WATER COMPANY	96	96	96	96	96	96	0	0	0	0	0	0	0	0	0	0	0	0		
GOLDEN BEAR FOREST PRODUCTS	30	30	33	33	33	32	0	0	0	0	0	0	0	0	0	0	0	0		
GRANT WATER COMPANY	429	424	483	436	363	427	0	0	0	0	0	0	0	0	0	0	0	0		
GREENSPOT MUTUAL WATER CO. TUNNEL						0	50	50	50	50	50	50								
GREENSPOT MUTUAL WELL COMPANY	142	149	121	105	76	119	215	311	141	138	188	199								

WESTERN - SAN BERNARDINO WATERMASTER
 TABLE 3 VERIFIED EXTRACTION SUMMARY
 VERIFIED EXTRACTIONS - FILED AND NON FILED

	-----BASE YEARS-----										-----CALENDAR YEAR EXTRACTIONS-----						
	1959	1960	1961	1962	1963	AVG	2008	2009	2010	2011	2012	AVG					
GREENSPOT VILLAGE & MARKET PLACE LLC	1,711	1,467	2,031	1,017	760	1,397	0	0	0	0	0	0					
GUERTH, WILLIAM H.	1,585	695	922	1,230	860	1,058	0	0	0	0	0	0					
HAGAR,	1	1	1	1	1	1	0	0	0	0	0	0					
HAPPE MUTUAL WELL COMPANY	526	592	649	358	500	525	24	97	71	79	63	67					
HARDISON,	1	1	1	1	1	1	1	1	1	0	1	1					
HARRISON CANYON	2	2	2	2	2	2	0	0	0	0	1	0					
HARRISON,	1	1	1	1	1	1	0	0	0	0	0	0					
HAZAS,	8	8	8	8	8	8	0	0	0	0	0	0					
HEAD, JOE T.	0	0	0	0	0	0	0	0	0	0	0	0					
HELIPORT	1	1	1	1	1	1	0	0	0	0	0	0					
HIGHLAND ACRES RANCH	250	160	350	400	400	312	0	0	0	0	0	0					
HIGHLAND WELL COMPANY	278	263	265	232	184	244	0	0	0	0	0	0					
HILL,	0	0	0	0	0	0	0	0	0	0	0	0					
HINCKLEY, HORACE P.	818	635	612	462	391	584	0	0	0	0	0	0					
HOLDEN MUTUAL WATER COMPANY	14	14	14	14	14	14	0	0	0	0	0	0					
HOLLIDAY TRUCKING	0	0	0	0	0	0	59	61	59	60	60	60					
HOLMES ICE & COLD STORAGE	591	405	410	345	344	419	0	0	0	0	0	0					
HOOVER WELL	100	100	100	60	60	60	0	0	0	0	0	0					
HORTON,	385	300	420	364	357	365	248	315	267	222	356	282					
HUNTER,	3	3	3	3	3	3	0	0	0	0	0	0					
INLAND VALLEY DEVELOPMENT AGENCY	5,892	5,295	5,478	5,985	5,340	5,598	75	0	0	0	0	15					
INTER CITY MUTUAL WATER COMPANY	0	0	0	0	0	0	0	0	0	0	0	0					
IOWA STREET WELL	62	62	21	10	7	32	0	0	0	0	0	0					
J. G. GOLFING ENTERPRISES	0	0	0	0	0	0	675	570	586	590	631	610					
JACINTO FARMING, LARRY	0	0	0	0	0	0	-	-	-	-	1	0					
JEWEL WATER COMPANY	504	408	356	293	258	364	0	0	0	0	0	0					
JUDSON MUTUAL WATER COMPANY	403	356	348	367	363	367	0	0	0	0	0	0					
K INV/ EVCA/ Y UN WELL	380	350	415	362	358	373	0	0	0	0	0	0					

WESTERN - SAN BERNARDINO WATERMASTER
 TABLE 3 VERIFIED EXTRACTION SUMMARY
 VERIFIED EXTRACTIONS - FILED AND NON FILED

	-----BASE YEARS-----										-----CALENDAR YEAR EXTRACTIONS-----				
	1959	1960	1961	1962	1963	AVG	2008	2009	2010	2011	2012	AVG			
KANSAS STREET MUTUAL WATER COMPANY	376	327	378	328	353	352	0	0	0	0	0	0			
KING STREET MUTUAL WELL COMPANY	408	371	358	281	372	358	5	5	5	5	5	5			
KING,	1	1	1	1	1	1	1	1	1	1	1	1			
KOCH,						0	0	0	0	0	0	0			
KOCH, GEORGE J.				0	0	0	0	0	0	0	0	0			
KRANTZ DAIRY	100	100	100	100	100	100	0	0	0	0	0	0			
KUJHN, RICHARD J.						0	0	0	0	0	0	0			
L P R ICE COMPANY WELL						0	0	0	0	0	0	0			
L. P. R. RANCH		485	660	610	351	351	0	0	0	0	0	0			
LA BONTE, JIM	5	5	5	5	5	5	4	4	4	4	4	4			
LA ROSSE, CHARLES H	38	21	35	18	14	25	0	0	0	0	0	0			
LAKESIDE AVENUE MUTUAL WELL COMPANY	79	48	58	51	20	51	0	0	0	0	0	0			
LANDMARK LAND COMPANY	212	143	147	88	43	127	0	0	0	0	0	0			
LANGSTON-NEWBY DEVELOPMENT COMPANY	50	50	50	50	50	50	0	0	0	0	0	0			
LOMA LINDA UNIVERSITY	1,011	1,116	1,202	1,166	901	1,079	1,400	1,359	1,293	1,343	1,417	1,362			
LOMA LINDA, CITY OF	1,827	1,840	1,991	1,729	1,290	1,735	4,713	4,624	4,863	5,401	5,776	5,075			
LULY, LUCIAN L		0	0	0	0	0	0	0	0	0	0	0			
MAJESTIC MANAGEMENT	395	302	468	381	367	383	0	0	0	0	0	0			
MARIGOLD FARMS COMPANY	465	636	547	1,033	386	613	250	250	250	289	225	253			
MARSHBURN,		380	300	290	194	194	100	100	100	100	100	100			
MAYBELL, N O	26	26	12	12	12	18	0	0	0	0	0	0			
MCCALLA BROS.		1	1	1	1	1	0	0	0	0	0	0			
MCCALLA, ROBERT	5	13	37	21	22	20	0	0	0	0	0	0			
MEADOWBROOK DAIRY	492	388	340	331	462	403	0	0	0	0	0	0			
MENTONE CITRUS GROWERS	714	873	637	409	306	588	666	740	648	916	942	782			
MENTONE DOMESTIC WATER COMPANY		25				5	0	0	0	0	0	0			
MEYER, CHARLES R	42	42	55	51	53	49	0	0	0	0	0	0			
MILLER MUTUAL WELL COMPANY	20	8	41	58	53	36	5	5	5	5	5	5			

WESTERN - SAN BERNARDINO WATERMASTER
 TABLE 3 VERIFIED EXTRACTION SUMMARY
 VERIFIED EXTRACTIONS - FILED AND NON FILED

	-----BASE YEARS-----										-----CALENDAR YEAR EXTRACTIONS-----									
	1959	1960	1961	1962	1963	AVG	2008	2009	2010	2011	2012	AVG	2008	2009	2010	2011	2012	AVG		
MONTE LLC	488	534	572	525	515	527	65	59	53	63	65	61	270	270	446	268	332	317		
MONTECITO MEMORIAL PARK	104	109	110	77	71	94	0	0	0	0	0	0	0	0	0	0	0	0		
MOORE, R. H.	46	42	89	78	77	66	0	0	0	0	0	0	0	0	0	0	0	0		
MOUNT VERNON WATER CO.	1,020	748	1,030	624	508	786	927	1,132	167	685	799	742	927	1,132	167	685	799	742		
MOUNTAIN VIEW POWER CO.	1,410	1,219	1,425	726	744	1,105	2,582	2,267	2,401	1,994	2,633	2,375	2,582	2,267	2,401	1,994	2,633	2,375		
MT. VIEW CEMETERY	228	185	145	250	141	190	245	235	242	262	275	252	245	235	242	262	275	252		
MT. VIEW CHILD CARE CENTER	2	2	2	2	2	2	0	0	0	0	0	0	0	0	0	0	0	0		
MUSCOY MUTUAL WATER COMPANY NO. 1	1,943	1,870	2,028	1,863	1,684	1,878	1,964	1,727	1,626	1,691	1,751	1,752	1,964	1,727	1,626	1,691	1,751	1,752		
NATIONAL ORANGE SHOW	135	135	135	135	135	135	20	50	1	50	62	37	20	50	1	50	62	37		
NEALEY MUTUAL WATER COMPANY	0	0	0	0	0	0	0	0	0	0	0	0	0	0	0	0	0	0		
NEW ENGLAND WATER COMPANY	212	220	348	297	250	265	0	229	250	200	195	247	0	229	250	200	195	247		
NICKERSON WATER COMPANY	466	331	490	424	290	400	0	0	0	0	0	0	0	0	0	0	0	0		
NICKERSON WATER COMPANY NO 2	30	27	32	28	28	29	0	0	0	0	0	0	0	0	0	0	0	0		
NO NAME WELL	476	443	416	464	396	439	0	0	0	0	0	0	0	0	0	0	0	0		
NORTH FORK WATER COMPANY	394	530	608	395	466	479	0	0	0	0	0	0	0	0	0	0	0	0		
NORTHBRAE WATER COMPANY	398	402	491	385	333	402	0	0	0	0	0	0	0	0	0	0	0	0		
NORTSIDE WATER COMPANY	1	1	1	1	1	1	0	0	0	0	0	0	0	0	0	0	0	0		
NORWOOD,	75	75	75	75	75	75	0	0	0	0	0	0	0	0	0	0	0	0		
PACIFIC HIGH SCHOOL							0	0	0	0	0	0	0	0	0	0	0	0		
PATTERSON, ROY H.							0	0	0	0	0	0	0	0	0	0	0	0		
PAYNE, LARRY							0	40	2	2	2	10	0	40	2	2	2	10		
PENN WELL COMPANY	539	447	504	550	440	496	0	0	0	0	0	0	0	0	0	0	0	0		
PHARAOHS LOST KINDGOM							0	50	50	33	30	43	0	50	50	33	30	43		
PHAROAH-POWELL WATER CO	326	350	365	371	322	347	199	241	182	169	218	202	199	241	182	169	218	202		
PIERSON,	80	80	80	80	80	64	0	0	0	0	0	0	0	0	0	0	0	0		
PIONEER MUTUAL WATER CO	314	222	288	316	275	283	30	20	21	22	24	23	30	20	21	22	24	23		
QUALITY FARMS	123	123	123	123	123	123	0	0	0	0	0	0	0	0	0	0	0	0		
RAMIREZ, J. J.	1,284	1,275	1,403	1,373	1,544	1,376	125	119	98	96	95	107	125	119	98	96	95	107		

WESTERN - SAN BERNARDINO WATERMASTER
 TABLE 3 VERIFIED EXTRACTION SUMMARY
 VERIFIED EXTRACTIONS - FILED AND NON FILED

	-----BASE YEARS-----							-----CALENDAR YEAR EXTRACTIONS-----						
	1959	1960	1961	1962	1963	AVG	2008	2009	2010	2011	2012	AVG		
RAMSEY,	1	1	1	1	1	1	0	0	0	0	0	0		
RANCHO CITRUS AMIGOS	80	80	80	80	80	80	0	0	0	0	0	0		
RAUGHT MUTUAL WELL COMPANY	504	550	552	506	520	526	204	248	215	239	255	232		
REDLANDS ASSOCIATES	489	378	438	414	411	426	0	0	0	0	0	0		
REDLANDS COUNTRY CLUB	174	96	696	692	532	438	0	0	0	0	0	0		
REDLANDS FARMING	773	647	444	435	463	552	0	0	0	0	0	0		
REDLANDS TRAP/SKEET	145	235	235	2	2	124	0	0	0	0	0	0		
REDLANDS UNIFIED SCHOOL DISTRICT	470	462	484	410	470	459	140	201	98	59	109	121		
REDLANDS WATER COMPANY	544	599	301	754	581	556	625	654	629	739	529	635		
REDLANDS, CITY OF	25,919	25,509	26,919	26,923	22,361	25,526	32,354	28,267	28,960	31,908	31,918	30,681		
REES & PERRICONE RANCH						0	0	0	0	0	0	0		
REES-REES RANCHES INC	10	163	452	88	330	209	0	0	0	0	0	0		
REGINA GRAPE PRODUCTS	250	250	250	250	250	250	0	0	0	0	0	0		
REYNOLDS, BILL	3	3	3	3	3	3	0	0	0	0	0	0		
RIALTO, CITY OF	2,618	1,622	1,834	2,101	1,867	2,008	6,545	5,713	5,325	3,377	3,109	4,814		
RIEDMAN, FRED M	230	230	230	230	15	187	0	0	0	0	0	0		
RIVAS,	1	1	1	1	1	1	0	0	0	0	0	0		
RIVAS, RAMON	30	43	0	0	0	15	0	0	0	0	0	0		
RIVENDELL LAND COMPANY	1,302	1,403	700	865	793	1,013	0	0	0	0	0	0		
ROBBINS, H W				18		4	5	5	5	5	5	5		
RULE,	1	1	1	1	1	1	0	0	0	0	0	0		
SAN BERNARDINO AVE WATER CO.	371	303	394	352	298	344	0	0	0	0	0	0		
SAN BERNARDINO COUNTY - FACILITY MANAGEMENT	1,881	1,548	1,832	1,635	1,241	1,627	1,027	1,180	1,040	858	866	994		
SAN BERNARDINO COUNTY - REGIONAL PARKS						0	34	40	39	4	39	31		
SAN BERNARDINO COUNTY FLOOD CONTROL	389	401	501	464	290	409	153	194	193	10	4	111		
SAN BERNARDINO VALLEY M.W.D.						0	761	752	291	618	3,790	1,242		
SAN BERNARDINO, CITY OF	21,379	19,803	22,081	20,645	19,277	20,637	58,316	54,066	49,185	50,331	50,250	52,430		
SAN MANUEL INDIAN RESERVATION	65	61	55	65	63	62	16	16	16	16	16	16		

WESTERN - SAN BERNARDINO WATERMASTER
 TABLE 3 VERIFIED EXTRACTION SUMMARY
 VERIFIED EXTRACTIONS - FILED AND NON FILED

	-----BASE YEARS-----							-----CALENDAR YEAR EXTRACTIONS-----						
	1959	1960	1961	1962	1963	AVG	2008	2009	2010	2011	2012	AVG		
SANDY'S RESTAURANT						0	0	0	0	0	0	0		
SANTINI,	90	90	90	90	90	90	0	0	0	0	0	0		
SATOSKI,	1	1	1	1	1	1	1	1	1	1	1	1		
SECHREST, RALPH F.	87	71	192	906	141	279	0	0	0	0	0	0		
SELBY DR & MRS	137	64	278	171	76	145	0	0	0	0	0	0		
SELEY,	1	1	1	1	1	1	0	0	0	0	0	0		
SIX HOUSES	6	6	6	6	6	6	0	0	0	0	0	0		
SMITH MEAT PACKING PLANT	3	3	3	3	3	3	0	0	0	0	0	0		
SMITH TRACT WELL COMPANY	270	177	56	0	127	126	0	0	0	0	0	0		
SMITH,	11	11	11	11	11	11	11	21	21	8	38	20		
SOJKA, DONALD R.	91	82	99	86	84	88	0	0	0	0	0	0		
SOLANO WELL NO 3				202	179	76	64	74	62	48	76	65		
SOMERS, R.	1	1	1	1	1	1	0	0	0	0	0	0		
SOUTHERN CALIFORNIA EDISON				883	883	353	0	0	0	0	0	0		
SOUZA, JOHN	7	7	9	10	9	8	0	0	0	0	0	0		
SPRING PACIFIC PROPERTY LLC	390	1,072	610	930	1,392	879	0	0	0	0	0	0		
STANLEY, SILAS	2	2	2	2	2	2	0	0	0	0	0	0		
STEWART, WILLARD	53	53	53	53	53	53	0	0	0	0	0	0		
STORKSON, DAVID D.	35	30	20	40	35	32	100	88	92	56	89	85		
STRAWBERRY PATCH	1	1	1	1	1	1	0	0	0	0	0	0		
SUNRISE RANCH PARTNERSHIP	1,857	1,693	2,119	2,037	1,992	1,940	0	0	0	0	0	0		
SUPERIOR ORCHARDS	1	1	1	1	1	1	0	0	0	0	0	0		
SYCAMORE HEIGHTS WATER COMPANY INC	420	52	52	52	52	126	0	0	0	0	0	0		
TENNESSEE MUTUAL WELL COMPANY	537	501	622	516	476	530	208	212	173	178	178	190		
TENNESSEE WATER COMPANY	530	530	540	540	550	538	309	303	226	192	211	248		
TERRACE WATER COMPANY	1,318	921	1,077	1,012	899	1,045	813	788	701	706	751	752		
TEXACO GAS STATION						0	0	0	0	0	0	0		
THOMPSON, RANDALL	3	3	3	3	3	3	0	0	0	0	0	0		

WESTERN - SAN BERNARDINO WATERMASTER
 TABLE 3 VERIFIED EXTRACTION SUMMARY
 VERIFIED EXTRACTIONS - FILED AND NON FILED

	-----BASE YEARS-----										-----CALENDAR YEAR EXTRACTIONS-----					
	1959	1960	1961	1962	1963	AVG	2008	2009	2010	2011	2012	AVG				
TILDEN, M WILLIAM	148	148	148	148	148	148	0	0	0	0	0	0				
TRAMMELL CROW COMPANY	991	876	572	429	772	728	0	0	0	0	0	0				
TRI-CITY CONCRETE	135	135	135	135	136	135	0	0	0	0	0	0				
TRI-CITY MUTUAL WATER COMPANY	53	20	0	0	0	15	0	0	0	0	0	0				
TRIPLE FALLS MUTUAL WATER COMPANY	15	12	10	15	18	14	0	0	0	0	0	0				
TROJAN GROVES	962	700	940	784	816	840	1	1	0	1	1	1				
U. S. FOREST SERVICE	9	9	9	9	9	9	0	0	0	0	0	0				
UNGER, V. E.						0	0	0	0	0	0	0				
UNIVERSITY OF REDLANDS						0	5	5	5	5	10	6				
UNKNOWN						0	0	0	0	0	0	0				
VALENCIA AVE. MUTUAL WATER COMPANY	30	30	30	30	30	30	0	0	0	0	0	0				
VALLEY FARMS MUTUAL WATER COMPANY	119	119	119	119	119	119	0	0	0	0	0	0				
VAN MEETER,	3	3	0	0	0	1	0	0	0	0	0	0				
VANLEUVEN, CLARENCE	26	26	26	26	26	26	0	0	0	0	0	0				
VICTORIA FARMS MUTUAL WATER CO	335	288	320	275	266	297	0	0	0	0	0	0				
VICTORIA GUERNSEY	163	248	200	160	223	199	0	0	0	0	0	0				
VICTORIA SEVENTH DAY ADVENTIST	15	15	15	15	15	15	10	10	10	10	10	10				
VILLAGE LAKES	220	194	179	190	224	201	85	85	85	85	85	85				
VULCAN - CAL MAT						0	1,086	224	130	134	119	339				
WALLACE,	1	1	1	1	1	1	1	1	1	1	0	1				
WARD, FLOYD	1	1	1	103	103	42	1	1	1	0	13	3				
WARMINGTON, ROBERT P.	300	248	288	153	139	226	0	0	0	0	0	0				
WEATHERWAX, W. G.	0	0	0	0	0	0	0	0	0	0	0	0				
WESSON, ROBERT CRAIG	133	147	180	120	116	139	8	8	4	14	14	10				
WEST VALLEY WATER DIST	13,584	12,090	13,587	11,331	11,837	12,486	13,754	12,716	7,986	7,697	8,637	10,158				
WESTERN FRUIT GROWERS	147	220	177	0	0	109	0	0	0	0	0	0				
WIDEMEYER,	6	6	6	6	6	6	0	0	0	0	0	0				
WILEY, RUTH NORWOOD						52	0	0	0	0	0	0				

WESTERN - SAN BERNARDINO WATERMASTER
 TABLE 3 VERIFIED EXTRACTION SUMMARY
 VERIFIED EXTRACTIONS - FILED AND NON FILED

	-----BASE YEARS-----										-----CALENDAR YEAR EXTRACTIONS-----				
	1959	1960	1961	1962	1963	AVG	2008	2009	2010	2011	2012	AVG			
WILLIAMS DAIRY	142	142	142	142	142	142	0	0	0	0	0	0			
WILLIAMS WELL CORPORATION LTD	721	684	765	706	595	694	394	363	421	388	460	405			
WOEHR MUTUAL WATER COMPANY	374	465	625	488	423	475	0	0	0	0	0	0			
YAHIKU, PAUL	50	95	51	51	51	60	0	0	0	0	0	0			
YUCAIPA VALLEY WATER DISTRICT						0	161	99	166	97	120	129			
TOTALS FOR 794 WELLS	190,243	174,107	181,037	175,103	157,729	175,644	189,335	169,860	160,639	165,053	175,002	171,978			

TOTAL VERIFIED
 PRODUCTION ALL
 FACILITIES 25
 G/ACRE-FEET PER
 YEAR OR LARGER

189,187 169,718 160,500 164,886 174,836 171,825

TABLE NO. 4

LYTLE CREEK VERIFICATION OF EXTRACTIONS FOR
CALENDAR YEARS 1959-1963 & 2008-2012

TABLE NO. 4

LYTLE CREEK
VERIFICATIONS OF EXTRACTIONS
FOR CALENDAR YEAR 1959

LINE NO.	LOCATION OF MEASUREMENT	JAN	FEB	MAR	APR	MAY	JUN	JUL	AUG	SEP	OCT	NOV	DEC	TOTAL	REMARKS
1	WEIR NO. 1	1,337	1,043	1,406	1,085	1,026	948	797	732	875	910	847	873	11,879	SEE NOTE 1
2	WEIR NO. 2	0	0	0	0	0	0	0	0	0	0	0	0	0	SEE NOTE 2
3	WEIR NO. 3	292	235	575	323	307	241	200	188	150	182	137	123	2,953	SEE NOTE 3
4	TOTAL OF WEIRS NOS. 1, 2 & 3	1,629	1,278	1,981	1,408	1,333	1,189	997	920	1,025	1,092	984	996	14,832	LINE 1 + 2 + 3
5	DEDUCT STREAM RETURN OVER 20' WEIR	8	3	0	0	0	0	0	0	0	0	0	0	0	SEE NOTE 4
6	TOTAL CALCULATED FLOW TO LOWER POWERHOUSE	1,621	1,275	1,981	1,408	1,333	1,189	997	920	1,025	1,092	984	996	14,821	LINE 4 - 5
7	ANNUAL PERCENT DIFFERENCE ----- X 100													-1.19 %	SEE NOTE 5
8	MEASURED FLOW TO LOWER POWERHOUSE	1,623	1,253	1,955	1,374	1,342	1,174	991	906	1,028	1,069	954	978	14,647	SEE NOTE 6
<u>DEDUCT MILLER NARROWS WELLS</u>															
9	WELL NO. 1 SDWR RECORDATION NO. 3600588	0	0	0	0	0	0	0	0	0	0	0	0	0	SEE NOTE 7
10	WELL NO. 2 SDWR RECORDATION NO. 3600590	0	0	0	0	141	333	341	340	268	266	259	237	2,185	SEE NOTE 7
11	TOTAL PUMPED WATER	0	0	0	0	141	333	341	340	268	266	259	237	2,185	LINE 9 + 10
12	STREAM FLOW DIVERTED FROM LYTLE CREEK	1,623	1,253	1,955	1,374	1,201	841	650	566	760	803	695	741	12,462	LINE 8 - 11
13	DEDUCT FLOW RETURNED TO STREAM BELOW LOWER POWERHOUSE	400	411	326	19	0	0	0	0	172	35	6	95	652	SEE NOTE 8
14	TOTAL STREAM DIVERSION AT LOWER POWERHOUSE	1,223	842	1,629	1,355	1,201	841	650	566	588	768	689	646	10,998	LINE 12 - 13
<u>BREED LINE CALCULATION</u>															
15	WEIR NO. 4	80	141	91	112	112	101	102	95	79	83	84	73	1,153	SEE NOTE 9
16	LESS WATER PUMPED BY FONTANA UNION WELL NO. 27 SDWR														
17	RECORDATION NO. 3600582	39	19	65	81	84	75	69	62	46	46	41	25	652	SEE NOTE 10
18	TOTAL STREAM DIVERSION AT FONTANA UNION INTAKE TO BREED LINE	41	122	26	31	28	26	33	33	33	37	43	48	501	LINE 15 - 16
19	TOTAL LYTLE CREEK STREAM DIVERSION AS VERIFIED	1,264	964	1,655	1,386	1,229	867	683	599	621	805	732	694	11,499	LINE 14 + 17

NOTES

- 1 WEIR NO. 1 MEASURES SOUTHERN CALIFORNIA EDISON CONDUIT NEAR FONTANA (USGS)
 - 2 WEIR NO. 2 MEASURES INFILTRATION LINE WATER TO FONTANA UNION INTAKE (USGS)
 - 3 WEIR NO. 3 MEASURES EITHER STREAM DIVERSION OR INFILTRATION WATER (USGS)
 - 4 20 FOOT WEIR MEASURES FLOW RETURNED TO STREAM AT INTAKE (FONTANA UNION)
 - 5 ANNUAL PERCENTAGE OF DIFFERENCE BETWEEN MEASURED & CALCULATED FLOW AT LOWER POWERHOUSE
 - 6 MEASURED FLOW AT LOWER POWERHOUSE (USGS) ASSUMED TO BE CORRECT
- NOTES
- 7 WATER EXTRACTED BY FONTANA UNION WATER COMPANY MILLER NARROWS WELLS AND DISCHARGED TO EDISON CONDUIT (FONTANA UNION).
 - 8 WATER RETURNED TO STREAM FROM AFTERBAY AT LOWER POWERHOUSE (FONTANA UNION)
 - 9 WEIR NO. 4 MEASURES FLOW TO BREED LINE AT INTAKE (USGS).
 - 10 FONTANA UNION WATER COMPANY WELL TO BREED LINE (FONTANA UNION)

TABLE NO. 4

LYTLE CREEK
VERIFICATIONS OF EXTRACTIONS
FOR CALENDAR YEAR 1960

LINE NO.	LOCATION OF MEASUREMENT	JAN	FEB	MAR	APR	MAY	JUN	JUL	AUG	SEP	OCT	NOV	DEC	TOTAL	REMARKS
1	WEIR NO. 1	989	1,007	956	772	855	591	497	456	432	520	666	704	8,445	SEE NOTE 1
2	WEIR NO. 2	0	0	0	0	0	0	0	0	0	0	0	0	0	SEE NOTE 2
3	WEIR NO. 3	118	125	141	113	136	146	152	135	125	112	78	145	1,526	SEE NOTE 3
4	TOTAL OF WEIRS NOS. 1, 2 & 3	1,107	1,132	1,097	885	991	737	649	591	557	632	744	849	9,971	LINE 1 + 2 + 3
5	DEDUCT STREAM RETURN OVER 20' WEIR	0	0	1	0	0	0	0	0	0	0	1	0	0	SEE NOTE 4
6	TOTAL CALCULATED FLOW TO LOWER POWERHOUSE	1,107	1,132	1,096	885	991	737	649	591	557	632	743	849	9,969	LINE 4 - 5
7	ANNUAL PERCENT DIFFERENCE ----- X 100													1.23 %	SEE NOTE 5
8	MEASURED FLOW TO LOWER POWERHOUSE	1,106	1,127	1,119	910	1,000	738	649	602	566	647	760	869	10,093	SEE NOTE 6
<u>DEDUCT MILLER NARROWS WELLS</u>															
9	WELL NO. 1 SDWR RECORDATION NO. 3600588	0	0	0	0	0	0	0	0	0	0	0	0	0	SEE NOTE 7
10	WELL NO. 2 SDWR RECORDATION NO. 3600590	186	213	280	244	302	293	302	299	291	302	159	274	3,145	SEE NOTE 7
11	TOTAL PUMPED WATER	186	213	280	244	302	293	302	299	291	302	159	274	3,145	LINE 9 + 10
12	STREAM FLOW DIVERTED FROM LYTLE CREEK	920	914	839	666	698	445	347	303	275	345	601	595	6,948	LINE 8 - 11
13	DEDUCT FLOW RETURNED TO STREAM BELOW LOWER POWERHOUSE	144	160	45	63	0	0	0	0	0	36	304	9	0	SEE NOTE 8
14	TOTAL STREAM DIVERSION AT LOWER POWERHOUSE	776	754	794	603	698	445	347	303	275	309	297	586	6,187	LINE 12 - 13
<u>BREED LINE CALCULATION</u>															
15	WEIR NO. 4	82	76	37	61	36	62	75	52	47	54	101	42	725	SEE NOTE 9
16	LESS WATER PUMPED BY FONTANA UNION WELL NO. 27 SDWR														
17	RECORDATION NO. 3600582	33	19	0	0	0	30	41	22	16	16	13	14	204	SEE NOTE 10
18	TOTAL LYTLE CREEK STREAM DIVERSION AS VERIFIED	49	57	37	61	36	32	34	30	31	38	88	28	521	LINE 15 - 16
19	MEASURED FLOW AT LOWER POWERHOUSE (USGS) ASSUMED TO BE CORRECT	825	811	831	664	734	477	381	333	306	347	385	614	6,708	LINE 14 + 17

NOTES

- 1 WEIR NO. 1 MEASURES SOUTHERN CALIFORNIA EDISON CONDUIT NEAR FONTANA (USGS)
 - 2 WEIR NO. 2 MEASURES INFILTRATION LINE WATER TO FONTANA UNION INTAKE (USGS)
 - 3 WEIR NO. 3 MEASURES EITHER STREAM DIVERSION OR INFILTRATION WATER (USGS)
 - 4 20 FOOT WEIR MEASURES FLOW RETURNED TO STREAM AT INTAKE (FONTANA UNION)
 - 5 ANNUAL PERCENTAGE OF DIFFERENCE BETWEEN MEASURED & CALCULATED FLOW AT LOWER POWERHOUSE
 - 6 MEASURED FLOW AT LOWER POWERHOUSE (USGS) ASSUMED TO BE CORRECT
- NOTES
- 7 WATER EXTRACTED BY FONTANA UNION WATER COMPANY MILLER NARROWS WELLS AND DISCHARGED TO EDISON CONDUIT (FONTANA UNION).
 - 8 WATER RETURNED TO STREAM FROM AFTERBAY AT LOWER POWERHOUSE (FONTANA UNION)
 - 9 WEIR NO. 4 MEASURES FLOW TO BREED LINE AT INTAKE (USGS).
 - 10 FONTANA UNION WATER COMPANY WELL TO BREED LINE (FONTANA UNION)

TABLE NO. 4

LYTLE CREEK
VERIFICATIONS OF EXTRACTIONS
FOR CALENDAR YEAR 1961

LINE NO.	LOCATION OF MEASUREMENT	JAN	FEB	MAR	APR	MAY	JUN	JUL	AUG	SEP	OCT	NOV	DEC	TOTAL	REMARKS
1	WEIR NO. 1	634	624	658	551	505	442	378	372	366	362	418	626	5,936	SEE NOTE 1
2	WEIR NO. 2	0	0	0	0	0	0	0	0	0	0	0	0	0	SEE NOTE 2
3	WEIR NO. 3	117	115	130	114	117	108	109	93	86	70	48	110	1,217	SEE NOTE 3
4	TOTAL OF WEIRS NOS. 1, 2 & 3	751	739	788	665	622	550	487	465	452	432	466	736	7,153	LINE 1 + 2 + 3
5	DEDUCT STREAM RETURN OVER 20' WEIR	2	0	0	0	0	0	0	0	0	0	0	3	3	SEE NOTE 4
6	TOTAL CALCULATED FLOW TO LOWER POWERHOUSE	749	739	788	665	622	550	487	465	452	432	466	733	7,148	LINE 4 - 5
7	ANNUAL PERCENT DIFFERENCE ----- X 100													2.52 %	SEE NOTE 5
8	MEASURED FLOW TO LOWER POWERHOUSE	752	762	813	700	637	544	488	480	472	431	469	785	7,333	SEE NOTE 6
	DEDUCT MILLER NARROWS WELLS														
9	WELL NO. 1 SDWR RECORDATION NO. 3600588	0	0	0	0	0	0	0	0	0	0	0	0	0	SEE NOTE 7
10	WELL NO. 2 SDWR RECORDATION NO. 3600590	220	231	265	253	262	253	262	259	250	261	233	257	3,006	SEE NOTE 7
11	TOTAL PUMPED WATER	220	231	265	253	262	253	262	259	250	261	233	257	3,006	LINE 9 + 10
12	STREAM FLOW DIVERTED FROM LYTLE CREEK	532	531	548	447	375	291	226	221	222	170	236	528	4,327	LINE 8 - 11
13	DEDUCT FLOW RETURNED TO STREAM BELOW LOWER POWERHOUSE	89	32	22	6	3	0	0	0	0	0	78	82	82	SEE NOTE 8
14	TOTAL STREAM DIVERSION AT LOWER POWERHOUSE	443	499	526	441	372	291	226	221	222	170	158	446	4,015	LINE 12 - 13
	BREED LINE CALCULATION														
15	WEIR NO. 4	65	35	31	32	35	32	32	33	31	32	45	68	471	SEE NOTE 9
16	LESS WATER PUMPED BY FONTANA UNION WELL NO. 27 SDWR														
17	RECORDATION NO. 3600582	13	1	1	3	4	6	8	6	3	4	3	6	58	SEE NOTE 10
	TOTAL STREAM DIVERSION AT FONTANA UNION INTAKE TO BREED LINE	52	34	30	29	31	26	24	27	28	28	42	62	413	LINE 15 - 16
18	TOTAL LYTLE CREEK STREAM DIVERSION AS VERIFIED	495	533	556	470	403	317	250	248	250	198	200	508	4,428	LINE 14 + 17

NOTES

- 1 WEIR NO. 1 MEASURES SOUTHERN CALIFORNIA EDISON CONDUIT NEAR FONTANA (USGS)
 - 2 WEIR NO. 2 MEASURES INFILTRATION LINE WATER TO FONTANA UNION INTAKE (USGS)
 - 3 WEIR NO. 3 MEASURES EITHER STREAM DIVERSION OR INFILTRATION WATER (USGS)
 - 4 20 FOOT WEIR MEASURES FLOW RETURNED TO STREAM AT INTAKE (FONTANA UNION)
 - 5 ANNUAL PERCENTAGE OF DIFFERENCE BETWEEN MEASURED & CALCULATED FLOW AT LOWER POWERHOUSE
 - 6 MEASURED FLOW AT LOWER POWERHOUSE (USGS) ASSUMED TO BE CORRECT
- NOTES
- 7 WATER EXTRACTED BY FONTANA UNION WATER COMPANY MILLER NARROWS WELLS AND DISCHARGED TO EDISON CONDUIT (FONTANA UNION).
 - 8 WATER RETURNED TO STREAM FROM AFTERBAY AT LOWER POWERHOUSE (FONTANA UNION)
 - 9 WEIR NO. 4 MEASURES FLOW TO BREED LINE AT INTAKE (USGS).
 - 10 FONTANA UNION WATER COMPANY WELL TO BREED LINE (FONTANA UNION)

TABLE NO. 4

LYTLE CREEK
VERIFICATIONS OF EXTRACTIONS
FOR CALENDAR YEAR 1962

LINE NO.	LOCATION OF MEASUREMENT	JAN	FEB	MAR	APR	MAY	JUN	JUL	AUG	SEP	OCT	NOV	DEC	TOTAL	REMARKS
1	WEIR NO. 1	698	721	1,448	1,359	966	847	738	636	738	1,289	1,327	1,254	12,021	SEE NOTE 1
2	WEIR NO. 2	0	196	403	0	0	0	0	0	0	0	0	0	599	SEE NOTE 2
3	WEIR NO. 3	177	335	526	477	327	290	238	230	208	196	183	174	3,361	SEE NOTE 3
4	TOTAL OF WEIRS NOS. 1, 2 & 3	875	1,252	2,377	1,836	1,293	1,137	976	866	946	1,485	1,510	1,428	15,981	LINE 1 + 2 + 3
5	DEDUCT STREAM RETURN OVER 20' WEIR	0	69	72	0	0	0	0	0	0	0	0	0	15,981	SEE NOTE 4
6	TOTAL CALCULATED FLOW TO LOWER POWERHOUSE	875	1,183	2,305	1,836	1,293	1,137	976	866	946	1,485	1,510	1,428	15,840	LINE 4 - 5
7	ANNUAL PERCENT DIFFERENCE ----- X 100													-0.96 %	SEE NOTE 5
8	MEASURED FLOW TO LOWER POWERHOUSE	894	1,187	2,386	1,827	1,291	1,113	978	845	904	1,450	1,454	1,361	15,690	SEE NOTE 6
<u>DEDUCT MILLER NARROWS WELLS</u>															
9	WELL NO. 1 SDWR RECORDATION NO. 3600588	0	0	0	0	0	0	0	0	0	0	0	0	0	SEE NOTE 7
10	WELL NO. 2 SDWR RECORDATION NO. 3600590	293	81	0	0	0	232	308	310	299	303	294	301	2,421	SEE NOTE 7
11	TOTAL PUMPED WATER	293	81	0	0	0	232	308	310	299	303	294	301	2,421	LINE 9 + 10
12	STREAM FLOW DIVERTED FROM LYTLE CREEK	601	1,106	2,386	1,827	1,291	881	670	535	605	1,147	1,160	1,060	13,269	LINE 8 - 11
13	DEDUCT FLOW RETURNED TO STREAM BELOW LOWER POWERHOUSE	49	515	809	616	20	0	0	0	0	31	0	0	13,269	SEE NOTE 8
14	TOTAL STREAM DIVERSION AT LOWER POWERHOUSE	552	591	1,577	1,211	1,271	881	670	535	605	1,116	1,160	1,060	11,229	LINE 12 - 13
<u>BREED LINE CALCULATION</u>															
15	WEIR NO. 4	41	143	40	101	81	77	77	73	65	59	43	32	832	SEE NOTE 9
16	LESS WATER PUMPED BY FONTANA UNION WELL NO. 27 SDWR														
17	RECORDATION NO. 3600582	2	8	3	59	42	40	38	34	28	33	18	1	306	SEE NOTE 10
18	TOTAL STREAM DIVERSION AT FONTANA UNION INTAKE TO BREED LINE	39	135	37	42	39	37	39	39	37	26	25	31	526	LINE 15 - 16
19	TOTAL LYTLE CREEK STREAM DIVERSION AS VERIFIED	591	726	1,614	1,253	1,310	918	709	574	642	1,142	1,185	1,091	11,755	LINE 14 + 17

NOTES

- 1 WEIR NO. 1 MEASURES SOUTHERN CALIFORNIA EDISON CONDUIT NEAR FONTANA (USGS)
 - 2 WEIR NO. 2 MEASURES INFILTRATION LINE WATER TO FONTANA UNION INTAKE (USGS)
 - 3 WEIR NO. 3 MEASURES EITHER STREAM DIVERSION OR INFILTRATION WATER (USGS)
 - 4 20 FOOT WEIR MEASURES FLOW RETURNED TO STREAM AT INTAKE (FONTANA UNION)
 - 5 ANNUAL PERCENTAGE OF DIFFERENCE BETWEEN MEASURED & CALCULATED FLOW AT LOWER POWERHOUSE
 - 6 MEASURED FLOW AT LOWER POWERHOUSE (USGS) ASSUMED TO BE CORRECT
- NOTES
- 7 WATER EXTRACTED BY FONTANA UNION WATER COMPANY MILLER NARROWS WELLS AND DISCHARGED TO EDISON CONDUIT (FONTANA UNION).
 - 8 WATER RETURNED TO STREAM FROM AFTERBAY AT LOWER POWERHOUSE (FONTANA UNION)
 - 9 WEIR NO. 4 MEASURES FLOW TO BREED LINE AT INTAKE (USGS).
 - 10 FONTANA UNION WATER COMPANY WELL TO BREED LINE (FONTANA UNION)

TABLE NO. 4

LYTLE CREEK
VERIFICATIONS OF EXTRACTIONS
FOR CALENDAR YEAR 1963

LINE NO.	LOCATION OF MEASUREMENT	JAN	FEB	MAR	APR	MAY	JUN	JUL	AUG	SEP	OCT	NOV	DEC	TOTAL	REMARKS
1	WEIR NO. 1	1,174	947	1,095	944	918	718	574	528	521	660	616	726	9,421	SEE NOTE 1
2	WEIR NO. 2	0	0	0	0	0	0	0	0	0	0	0	0	0	SEE NOTE 2
3	WEIR NO. 3	155	145	223	194	196	154	154	139	75	73	68	74	1,650	SEE NOTE 3
4	TOTAL OF WEIRS NOS. 1, 2 & 3	1,329	1,092	1,318	1,138	1,114	872	728	667	596	733	684	800	11,071	LINE 1 + 2 + 3
5	DEDUCT STREAM RETURN OVER 20' WEIR	0	0	0	0	0	0	0	0	0	0	4	0	0	SEE NOTE 4
6	TOTAL CALCULATED FLOW TO LOWER POWERHOUSE	1,329	1,092	1,318	1,138	1,114	872	728	667	596	733	680	800	11,067	LINE 4 - 5
7	ANNUAL PERCENT DIFFERENCE ----- X 100													0.49 %	SEE NOTE 5
8	MEASURED FLOW TO LOWER POWERHOUSE	1,246	1,038	1,273	1,121	1,109	881	742	688	615	803	725	881	11,122	SEE NOTE 6
<u>DEDUCT MILLER NARROWS WELLS</u>															
9	WELL NO. 1 SDWR RECORDATION NO. 3600588	0	0	0	0	0	0	0	0	0	0	0	0	0	SEE NOTE 7
10	WELL NO. 2 SDWR RECORDATION NO. 3600590	296	172	253	283	299	289	294	303	201	277	183	312	3,162	SEE NOTE 7
11	TOTAL PUMPED WATER	296	172	253	283	299	289	294	303	201	277	183	312	3,162	LINE 9 + 10
12	STREAM FLOW DIVERTED FROM LYTLE CREEK	950	866	1,020	838	810	592	448	385	414	526	542	569	7,960	LINE 8 - 11
13	DEDUCT FLOW RETURNED TO STREAM BELOW LOWER POWERHOUSE	11	100	51	64	10	0	16	0	219	36	112	2	0	SEE NOTE 8
14	TOTAL STREAM DIVERSION AT LOWER POWERHOUSE	939	766	969	774	800	592	432	385	195	490	430	567	7,339	LINE 12 - 13
<u>BREED LINE CALCULATION</u>															
15	WEIR NO. 4	32	64	42	41	31	29	37	42	85	51	68	42	564	SEE NOTE 9
16	LESS WATER PUMPED BY FONTANA UNION WELL NO. 27 SDWR	0	0	0	2	0	0	10	17	7	0	0	6	42	SEE NOTE 10
17	TOTAL STREAM DIVERSION AT FONTANA UNION INTAKE TO BREED LINE	32	64	42	39	31	29	27	25	78	51	68	36	522	LINE 15 - 16
18	TOTAL LYTLE CREEK STREAM DIVERSION AS VERIFIED	971	830	1,011	813	831	621	459	410	273	541	498	603	7,861	LINE 14 + 17

NOTES

- 1 WEIR NO. 1 MEASURES SOUTHERN CALIFORNIA EDISON CONDUIT NEAR FONTANA (USGS)
 - 2 WEIR NO. 2 MEASURES INFILTRATION LINE WATER TO FONTANA UNION INTAKE (USGS)
 - 3 WEIR NO. 3 MEASURES EITHER STREAM DIVERSION OR INFILTRATION WATER (USGS)
 - 4 20 FOOT WEIR MEASURES FLOW RETURNED TO STREAM AT INTAKE (FONTANA UNION)
 - 5 ANNUAL PERCENTAGE OF DIFFERENCE BETWEEN MEASURED & CALCULATED FLOW AT LOWER POWERHOUSE
 - 6 MEASURED FLOW AT LOWER POWERHOUSE (USGS) ASSUMED TO BE CORRECT
- NOTES
- 7 WATER EXTRACTED BY FONTANA UNION WATER COMPANY MILLER NARROWS WELLS AND DISCHARGED TO EDISON CONDUIT (FONTANA UNION).
 - 8 WATER RETURNED TO STREAM FROM AFTERBAY AT LOWER POWERHOUSE (FONTANA UNION)
 - 9 WEIR NO. 4 MEASURES FLOW TO BREED LINE AT INTAKE (USGS).
 - 10 FONTANA UNION WATER COMPANY WELL TO BREED LINE (FONTANA UNION)

TABLE NO. 4

LYTLE CREEK
VERIFICATIONS OF EXTRACTIONS
FOR CALENDAR YEAR 2008
In Acre Feet

LINE NO.	LOCATION OF MEASUREMENT	JAN	FEB	MAR	APR	MAY	JUN	JUL	AUG	SEP	OCT	NOV	DEC	TOTAL	REMARKS
1	WEIR NO. 1 [110609000]	434	910	1,040	996	852	732	533	568	582	823	753	774	8,997	SEE NOTE 1
2	WEIR NO. 2 [11062399]	17	270	208	9	0	0	0	0	0	0	0	0	0	SEE NOTE 2
2a	WEIR NO. 3 [11062400]	18	272	219	6	0	0	0	0	0	0	0	0	0	
2b	WEIR No. 2 and No. 3 [11062402]	35	542	427	15	0	0	0	0	0	0	0	0	0	Weir 2 & 3 combined
3	INFILTRATION LINE METER [11061000]	514	609	612	579	501	416	327	294	299	288	290	420	5,149	SEE NOTE 3
4	TOTAL OF WEIRS NOS. 1, 2 & 3 and INFILTRATION	983	2,061	2,079	1,590	1,353	1,148	860	862	881	1,111	1,043	1,194	15,165	LINE 1+2+3
5	DEDUCT STREAM RETURN OVER 20' WEIR [11062450]	110	85	38	0	0	0	0	0	0	0	0	0	233	SEE NOTE 4
6	TOTAL CALCULATED FLOW TO LOWER POWERHOUSE	873	1,976	2,041	1,590	1,353	1,148	860	862	881	1,111	1,043	1,194	14,932	LINE 4-5
7	ANNUAL PERCENT DIFFERENCE ----- X 100													-8.23 %	SEE NOTE 5
8	MEASURED FLOW TO LOWER POWERHOUSE [11062700]	848	1,980	1,940	1,370	1,180	984	819	718	778	1,090	1,020	1,070	13,797	SEE NOTE 6
DEDUCT MILLER NARROWS WELLS															
9	WELL NO. 1 RECORDATION NO. 3600588 [FC in 1981]														SEE NOTE 7
10	WELL NO. 2 RECORDATION NO. 3600590 [FC in 1986]														SEE NOTE 7
11	TOTAL PUMPED WATER														LINE 9+10
12	STREAM FLOW DIVERTED FROM LYTLE CRK TO LOWER POWERHOUSE	848	1,980	1,940	1,370	1,180	984	819	718	778	1,090	1,020	1,070	13,797	LINE 8-11
DEDUCT FLOW RETURNED TO STREAM BELOW LOWER POWERHOUSE															
13	RETURN FLOW FROM AFTERBAY [11062800]	617	691	101	45	109	25	73	86	61	24	27	154	2,013	SEE NOTE 8
14	RETURN FLOW FROM WSBICWD DIVISION BOX														SEE NOTE 11
15	TOTAL RETURN FLOW BELOW LOWER POWERHOUSE	617	691	101	45	109	25	73	86	61	24	27	154	2,013	LINE 13+14
16	NET STREAM FLOW DIVERSION AT LOWER POWERHOUSE	231	1,289	1,839	1,325	1,071	959	746	632	717	1,066	993	916	11,784	LINE 12-15
BREED LINE CALCULATION															
17	WEIR NO. 4														SEE NOTE 9
18	LESS WATER PUMPED BY FONTANA UNION WELL NO. 27														SEE NOTE 10
19	RECORDATION NO. 3600582 NET LYTLE CREEK STREAM FLOW AT FONTANA UNION INTAKE TO BREED LINE														LINE 17-18
20	TOTAL LYTLE CREEK STREAM FLOW DIVERSION AS VERIFIED	231	1,289	1,839	1,325	1,071	959	746	632	717	1,066	993	916	11,784	LINE 16+19
NOTES															
1	WEIR NO. 1 MEASURES SOUTHERN CALIFORNIA EDISON CONDUIT NEAR FONTANA (USGS)														7
2	WEIR NO. 2 MEASURES STREAM DIVERSION (USGS)														8
3	WEIR NO. 3 MEASURES STREAM DIVERSION (USGS)														9
4	20 FOOT WEIR MEASURES FLOW RETURNED TO STREAM AT INTAKE (USGS)														10
5	ANNUAL PERCENTAGE OF DIFFERENCE BETWEEN MEASURED & CALCULATED FLOW AT LOWER POWERHOUSE														11
6	MEASURED FLOW AT LOWER POWERHOUSE (USGS) ASSUMED TO BE CORRECT														

TABLE NO. 4

LYTLE CREEK
VERIFICATIONS OF EXTRACTIONS
FOR CALENDAR YEAR 2009
In Acre Feet

LINE NO.	LOCATION OF MEASUREMENT	JAN	FEB	MAR	APR	MAY	JUN	JUL	AUG	SEP	OCT	NOV	DEC	TOTAL	REMARKS
1	WEIR NO. 1 [11060900]	912	631	895	503	835	706	528	472	429	491	526	703	7,631	SEE NOTE 1
2	WEIR NO. 2 [11062399]										0	0	0	26	SEE NOTE 2
2a	WEIR NO. 3 [11062400]										0	0	0	27	
2b	WEIR NO. 2 and No. 3 [11062402]														Weir 2 & 3 combined
3	INFILTRATION LINE METER [11061000]	377	386	455	450	329	261	251	229	213	240	256	391	3,838	SEE NOTE 3
4	TOTAL OF WEIRS NOS. 1, 2 & 3 and INFILTRATION	1,289	1,192	1,562	1,172	1,164	967	779	701	642	731	782	1,147	12,128	LINE 1+2+3
5	DEDUCT STREAM RETURN OVER 20' WEIR [11062450]	0	2	0	0	0	0	0	0	0	0	0	0	2	SEE NOTE 4
6	TOTAL CALCULATED FLOW TO LOWER POWERHOUSE	1,289	1,190	1,562	1,172	1,164	967	779	701	642	731	782	1,147	12,126	LINE 4-5
7	ANNUAL PERCENT DIFFERENCE ----- X 100 LINE 8 - LINE 6													-3.41 %	SEE NOTE 5
8	MEASURED FLOW TO LOWER POWERHOUSE [11062700]	1,210	1,180	1,570	1,240	1,130	902	734	664	598	678	730	1,090	11,726	SEE NOTE 6
DEDUCT MILLER NARROWS WELLS															
WELL NO. 1 RECORDATION NO. 3600588 [FC in 1981]															
WELL NO. 2 RECORDATION NO. 3600590 [FC in 1986]															
TOTAL PUMPED WATER															
16	STREAM FLOW DIVERTED FROM LYTLE CRK TO LOWER POWERHOUSE	1,210	1,180	1,570	1,240	1,130	902	734	664	598	678	730	1,090	11,726	LINE 8-11
DEDUCT FLOW RETURNED TO STREAM BELOW LOWER POWERHOUSE															
RETURN FLOW FROM AFTERBAY [11062800]															
RETURN FLOW FROM WSBOWD DIVISION BOX															
16	TOTAL RETURN FLOW BELOW LOWER POWERHOUSE	440	528	373	72	33	20	0	24	28	33	48	196	1,795	SEE NOTE 8
16	NET STREAM FLOW DIVERSION AT LOWER POWERHOUSE	770	652	1,197	1,168	1,097	882	734	640	570	645	682	894	9,931	SEE NOTE 11 LINE 13+14 LINE 12-15
BREED LINE CALCULATION															
17	WEIR NO. 4														SEE NOTE 9
18	LESS WATER PUMPED BY FONTANA UNION WELL NO. 27														SEE NOTE 10
RECORDATION NO.: 3600582															
19	NET LYTLE CREEK STREAM FLOW AT FONTANA UNION INTAKE TO BREED LINE														LINE 17-18
20	TOTAL LYTLE CREEK STREAM FLOW DIVERSION AS VERIFIED	770	652	1,197	1,168	1,097	882	734	640	570	645	682	894	9,931	LINE 16+19
NOTES															
1	WEIR NO. 1 MEASURES SOUTHERN CALIFORNIA EDISON CONDUIT NEAR FONTANA (USGS)														7
2	WEIR NO. 2 MEASURES STREAM DIVERSION (USGS)														8
3	WEIR NO. 3 MEASURES STREAM DIVERSION (USGS)														9
4	20 FOOT WEIR MEASURES FLOW RETURNED TO STREAM AT INTAKE (USGS)														10
5	ANNUAL PERCENTAGE OF DIFFERENCE BETWEEN MEASURED & CALCULATED FLOW AT LOWER POWERHOUSE														11
6	MEASURED FLOW AT LOWER POWERHOUSE (USGS) ASSUMED TO BE CORRECT														

TABLE NO. 4
LYTLE CREEK
VERIFICATIONS OF EXTRACTIONS
FOR CALENDAR YEAR 2010
In Acre Feet

LINE NO.	LOCATION OF MEASUREMENT	JAN	FEB	MAR	APR	MAY	JUN	JUL	AUG	SEP	OCT	NOV	DEC	TOTAL	REMARKS
1	WEIR NO. 1 [110609000]	516	594	953	954	1,030	966	916	704	990	527	933	507	9,590	SEE NOTE 1
2	WEIR NO. 2 [11062399]	16	517	669	398	238	49	0	24	5	255	107	103	2,381	SEE NOTE 2
2a	WEIR NO. 3 [11062400]	17	536	702	441	263	56	0	28	8	288	121	106	2,566	
2b	WEIR No. 2 and No. 3 [11062402]													0	Weir 2 & 3 combined
3	INFILTRATION LINE METER [11061000]	428	485	473	443	460	413	259	331	326	418	335	497	4,868	SEE NOTE 3
4	TOTAL OF WEIRS NOS. 1, 2 & 3 and INFILTRATION	977	2,132	2,797	2,236	1,991	1,484	1,175	1,087	1,329	1,488	1,496	1,213	19,405	LINE 1+2+3
5	DEDUCT STREAM RETURN OVER 20' WEIR [11062450]	41	283	189	24	0	0	0	0	0	29	3	125	694	SEE NOTE 4
6	TOTAL CALCULATED FLOW TO LOWER POWERHOUSE	936	1,849	2,608	2,212	1,991	1,484	1,175	1,087	1,329	1,459	1,493	1,088	18,711	LINE 4-5
7	ANNUAL PERCENT DIFFERENCE ----- X 100													-6.40 %	SEE NOTE 5
8	MEASURED FLOW TO LOWER POWERHOUSE [11062700]	792	1,819	2,694	2,243	1,845	1,442	1,192	975	1,142	1,313	1,256	872	17,585	SEE NOTE 6
<u>DEDUCT MILLER NARROWS WELLS</u>															
WELL NO. 1 RECORDATION NO. 3600588 [FC in 1981]															
WELL NO. 2 RECORDATION NO. 3600590 [FC in 1986]															
TOTAL PUMPED WATER															
9	STREAM FLOW DIVERTED FROM LYTLE CRK TO LOWER POWERHOUSE	792	1,819	2,694	2,243	1,845	1,442	1,192	975	1,142	1,313	1,256	872	17,585	LINE 8-11
10	DUCT FLOW RETURNED TO STREAM BELOW LOWER POWERHOUSE	158	759	388	154	37	7	64	42	15	22	90	277	2,013	SEE NOTE 7
11	RETURN FLOW FROM AFTERBAY [11062800]	158	759	388	154	37	7	64	42	15	22	90	277	2,013	SEE NOTE 7
12	RETURN FLOW FROM WSBOWD DIVISION BOX														LINE 9+10
13	TOTAL RETURN FLOW BELOW LOWER POWERHOUSE	634	1,060	2,306	2,089	1,808	1,435	1,128	933	1,127	1,291	1,166	595	15,572	SEE NOTE 8
14	NET STREAM FLOW DIVERSION AT LOWER POWERHOUSE														SEE NOTE 11
15	BREED LINE CALCULATION														LINE 12-15
16	WEIR NO. 4														SEE NOTE 9
17	LESS WATER PUMPED BY FONTANA UNION WELL NO. 27														SEE NOTE 10
18	RECORDATION NO. 3600582														LINE 17-18
19	NET LYTLE CREEK STREAM FLOW AT FONTANA UNION INTAKE TO BREED LINE														LINE 16+19
20	TOTAL LYTLE CREEK STREAM FLOW DIVERSION AS VERIFIED	634	1,060	2,306	2,089	1,808	1,435	1,128	933	1,127	1,291	1,166	595	15,572	

Record discontinued. WEIR NO. 4 receives FUWC WELL NO. 27 production only.

NOTES

7 WATER EXTRACTED BY FONTANA UNION WATER COMPANY MILLER NARROWS WELLS AND DISCHARGED TO EDISON CONDUIT (FONTANA UNION)

8 WATER RETURNED TO STREAM FROM AFTERBAY AT LOWER POWERHOUSE FONTANA UNION (USGS)

9 WEIR NO. 4 MEASURES FLOW TO BREED LINE AT INTAKE (USGS)

10 FONTANA UNION WATER COMPANY WELL TO BREED LINE (FONTANA UNION)

11 WATER RETURNED TO STREAM FROM WEST SAN BERNARDINO COUNTY WATER DISTRICT DIVISION BOX (WEST VALLEY COUNTY WD)

TABLE NO. 4
 LYTLE CREEK
 VERIFICATIONS OF EXTRACTIONS
 FOR CALENDAR YEAR 2011
 In Acre Feet

LINE NO.	LOCATION OF MEASUREMENT	JAN	FEB	MAR	APR	MAY	JUN	JUL	AUG	SEP	OCT	NOV	DEC	TOTAL	REMARKS
1	LYTLE CREEK STREAM FLOW [11062000]	4,377	3,132	3,316	4,522	3,295	2,432	2,287	864	1,195	1,519	721	573	28,233	SEE NOTE 1
2	LYTLE CREEK STREAM FLOW, UPPER PH AND INFILTRATION[11062001]	5,488	4,403	5,008	6,240	4,975	3,973	3,824	2,366	2,372	1,976	2,033	1,504	44,162	SEE NOTE 2
3	LYTLE CREEK SURFACE DIVERSION WEIR NO. 2 AND NO. 3 [11062002]	0	751	1,543	2,083	1,940	1,561	2,146	1,763	1,325	1,670	361	0	15,143	SEE NOTE 3
4	NET FLOW TO LOWER POWERHOUSE	1,111	2,022	3,235	3,801	3,620	3,102	3,683	3,265	2,502	2,127	1,673	931	31,072	LINE 1+2+3
5	DEDUCT STREAM RETURN OVER 20' WEIR [11062450]	0	194	511	1,200	863	751	1,020	500	7	4	16	0	5,066	SEE NOTE 4
6	TOTAL CALCULATED FLOW TO LOWER POWERHOUSE	1,111	1,828	2,724	2,601	2,757	2,351	2,663	2,765	2,495	2,123	1,657	931	26,006	LINE 4-5
7	ANNUAL PERCENT DIFFERENCE ----- X 100													-5.09 %	SEE NOTE 5
8	MEASURED FLOW TO LOWER POWERHOUSE [11062700]	947	1,551	2,227	2,638	2,813	2,369	2,622	2,807	2,461	2,101	1,577	634	24,747	SEE NOTE 6
<u>DEDUCT MILLER NARROWS WELLS</u>															
WELL NO. 1 RECORDATION NO. 3600588 [FC in 1981]															
WELL NO. 2 RECORDATION NO. 3600590 [FC in 1986]															
TOTAL PUMPED WATER															
9	STREAM FLOW DIVERTED FROM LYTLE CRK TO LOWER POWERHOUSE	947	1,551	2,227	2,638	2,813	2,369	2,622	2,807	2,461	2,101	1,577	634	24,747	LINE 8-11
<u>DEDUCT FLOW RETURNED TO STREAM BELOW LOWER POWERHOUSE</u>															
10	RETURN FLOW FROM AFTERBAY [11062800]	680	431	475	255	55	34	115	67	33	207	189	108	2,649	SEE NOTE 8
11	RETURN FLOW FROM WSBCWD DIVISION BOX	680	431	475	255	55	34	115	67	33	207	189	108	2,649	SEE NOTE 11
12	TOTAL RETURN FLOW BELOW LOWER POWERHOUSE	267	1,120	1,752	2,383	2,758	2,335	2,507	2,740	2,428	1,894	1,388	526	22,098	LINE 13+14
13	NET STREAM FLOW DIVERSION AT LOWER POWERHOUSE														LINE 12-15
<u>BREED LINE CALCULATION</u>															
14	WEIR NO. 4														SEE NOTE 9
15	LESS WATER PUMPED BY FONTANA UNION WELL NO. 27														SEE NOTE 10
16	RECORDATION NO. 3600582														LINE 17-18
17	NET LYTLE CREEK STREAM FLOW AT FONTANA UNION INTAKE TO BREED LINE														LINE 16+19
18	TOTAL LYTLE CREEK STREAM FLOW DIVERSION AS VERIFIED	267	1,120	1,752	2,383	2,758	2,335	2,507	2,740	2,428	1,894	1,388	526	22,098	
<u>NOTES</u>															
19	MEASURED FLOW OF LYTLE CREEK (USGS)	7													
20	FLOW OF LYTLE CREEK PLUS UPPER POWERHOUSE PLUS INFILTRATION LINE (USGS)	8													
21	LYTLE CREEK SURFACE DIVERSION INCLUDES WEIR NO. 2 AND WEIR NO. 3 (USGS)	9													
22	20 FOOT WEIR MEASURES FLOW RETURNED TO STREAM AT INTAKE (USGS)	10													
23	ANNUAL PERCENTAGE OF DIFFERENCE BETWEEN MEASURED & CALCULATED FLOW AT LOWER POWERHOUSE	11													
24	MEASURED FLOW AT LOWER POWERHOUSE (USGS) ASSUMED TO BE CORRECT														

Record discontinued. WEIR NO. 4 receives FUWC WELL NO. 27 production only.

NOTES

7 WATER EXTRACTED BY FONTANA UNION WATER COMPANY MILLER NARROWS WELLS AND DISCHARGED TO EDISON CONDUIT (FONTANA UNION)

8 WATER RETURNED TO STREAM FROM AFTERBAY AT LOWER POWERHOUSE FONTANA UNION (USGS)

9 WEIR NO. 4 MEASURES FLOW TO BREED LINE AT INTAKE (USGS)

10 FONTANA UNION WATER COMPANY WELL TO BREED LINE (FONTANA UNION)

11 WATER RETURNED TO STREAM FROM WEST SAN BERNARDINO COUNTY WATER DISTRICT DIVISION BOX (WEST VALLEY COUNTY WD)

TABLE NO. 4
LYTLE CREEK
VERIFICATIONS OF EXTRACTIONS
FOR CALENDAR YEAR 2012
In Acre Feet

LINE NO.	LOCATION OF MEASUREMENT	JAN	FEB	MAR	APR	MAY	JUN	JUL	AUG	SEP	OCT	NOV	DEC	TOTAL	REMARKS
1	WEIR NO. 1 [11060900]	1,045	978	779	820	597	661	535	558	459	431	467	629	7,959	SEE NOTE 1
2	WEIR NO. 2 [11062399]	0	4	100	97	4	0	0	0	0	0	0	0	205	SEE NOTE 2
2a	WEIR NO. 3 [11062400]	0	3	88	50	1	0	0	0	0	0	0	0	142	SEE NOTE 3
2b	WEIR No. 2 and No. 3 [11062402]													0	Weir 2 & 3 combined during WY 2006
3	INFILTRATION LINE METER [11061000]	274	243	317	377	371	304	275	264	206	208	199	268	3,306	LINE 1+2+3
4	TOTAL OF WEIRS NOS. 1, 2 & 3 and INFILTRATION	1,319	1,228	1,284	1,344	973	965	810	822	665	639	666	897	11,612	SEE NOTE 4
5	DEDUCT STREAM RETURN OVER 20' WEIR [11062450]	0	0	0	0	0	0	0	0	0	0	0	0	0	SEE NOTE 4
6	TOTAL CALCULATED FLOW TO LOWER POWERHOUSE	1,319	1,228	1,284	1,344	973	965	810	822	665	639	666	897	11,612	LINE 4-5
7	ANNUAL PERCENT DIFFERENCE ----- X 100													-10.23 %	SEE NOTE 5
8	MEASURED FLOW TO LOWER POWERHOUSE [11062700]	1,230	1,139	1,184	1,155	774	954	760	740	597	570	594	837	10,534	SEE NOTE 6
DEDUCT MILLER NARROWS WELLS															
WELL NO. 1 RECORDATION NO. 3600588 [FC in 1981]															
WELL NO. 2 RECORDATION NO. 3600590 [FC in 1986]															
TOTAL PUMPED WATER															
9	STREAM FLOW DIVERTED FROM LYTLE CRK TO LOWER POWERHOUSE	1,230	1,139	1,184	1,155	774	954	760	740	597	570	594	837	10,534	SEE NOTE 7
DEDUCT FLOW RETURNED TO STREAM BELOW LOWER POWERHOUSE															
10	RETURN FLOW FROM AFTERBAY [11062800]	28	17	154	41	83	8	11	142	36	25	60	205	810	SEE NOTE 8
11	RETURN FLOW FROM WSBCWD DIVISION BOX	28	17	154	41	83	8	11	142	36	25	60	205	810	SEE NOTE 11
12	TOTAL RETURN FLOW BELOW LOWER POWERHOUSE	56	34	308	82	166	16	22	284	72	50	120	410	1,620	LINE 13+14
13	NET STREAM FLOW DIVERSION AT LOWER POWERHOUSE	1,202	1,122	1,030	1,114	691	946	749	598	561	545	534	632	9,724	LINE 12-15
BREED LINE CALCULATION															
14	WEIR NO. 4														SEE NOTE 9
15	LESS WATER PUMPED BY FONTANA UNION WELL NO. 27														SEE NOTE 10
16	RECORDATION NO. 3600582														SEE NOTE 10
17	NET LYTLE CREEK STREAM FLOW AT FONTANA UNION INTAKE TO BREED LINE														LINE 17-18
18	TOTAL LYTLE CREEK STREAM FLOW DIVERSION AS VERIFIED	1,202	1,122	1,030	1,114	691	946	749	598	561	545	534	632	9,724	LINE 16+19
NOTES															
1	WEIR NO. 1 MEASURES SOUTHERN CALIFORNIA EDISON CONDUIT NEAR FONTANA (USGS)														
2	WEIR NO. 2 MEASURES STREAM DIVERSION (USGS)														
3	WEIR NO. 3 MEASURES STREAM DIVERSION (USGS)														
4	20 FOOT WEIR MEASURES FLOW RETURNED TO STREAM AT INTAKE (USGS)														
5	ANNUAL PERCENTAGE OF DIFFERENCE BETWEEN MEASURED & CALCULATED FLOW AT LOWER POWERHOUSE														
6	MEASURED FLOW AT LOWER POWERHOUSE (USGS) ASSUMED TO BE CORRECT														
7	WATER EXTRACTED BY FONTANA UNION WATER COMPANY MILLER NARROWS WELLS AND DISCHARGED TO EDISON CONDUIT (FONTANA UNION).														
8	WATER RETURNED TO STREAM FROM AFTERBAY AT LOWER POWERHOUSE FONTANA UNION (USGS)														
9	WEIR NO. 4 MEASURES FLOW TO BREED LINE AT INTAKE (USGS).														
10	FONTANA UNION WATER COMPANY WELL TO BREED LINE (FONTANA UNION)														
11	WATER RETURNED TO STREAM FROM WEST SAN BERNARDINO COUNTY WATER DISTRICT DIVISION BOX (WEST VALLEY COUNTY WD)														

TABLE NO. 5

MILL CREEK VERIFICATION OF EXTRACTIONS FOR
CALENDAR YEARS 2008-2012

TABLE NO. 5

MILL CREEK
VERIFICATIONS OF EXTRACTIONS
FOR CALENDAR YEAR 2008

LINE NO.	LOCATION OF MEASUREMENT	JAN	FEB	MAR	APR	MAY	JUN	JUL	AUG	SEP	OCT	NOV	DEC	TOTAL	REMARKS
1	MILL CREEK NEAR YUCAIPA STREAMFLOW	340	583	834	1,020	948	968	791	687	546	672	493	533	8,415	SEE NOTE 1
2	MILL CREEK NEAR YUCAIPA POWER CANALS [11052500]							Station Discontinued							SEE NOTE 1
3	MILL CREEK NEAR YUCAIPA COMBINED FLOW	340	583	834	1,020	948	968	791	687	546	672	493	533	8,415	SEE NOTE 1
4	TOTAL FLOW AVAILABLE FOR DIVERSION							Station Discontinued							LINE 3
DIVERSIONS															
5	MILL CREEK NO. 2 & 3 POWERHOUSE AFTERBAY	0	0	0	0	0	0	0	0	0	0	0	0	0	SEE NOTE 2
	DIVERSION TO YUCAIPA: "Total Mill Creek Water " Ln 50x														
CITY OF REDLANDS TATE FILTER PLANT															
6	TATE FILTER PLANT [HTWTP Effluent]	301	259	384	909	779	988	910	777	619	766	607	457	7,756	SEE NOTE 3
7	LESS FILTER BACK & SURF WASH WATER RETURNED TO ZANJA														SEE NOTE 3
7A	RETURN TO MILL CREEK FROM TATE TREATMENT PLANT	61	0	13	0	15	0	6	0	9	1	1	5	111	
8	LESS GROUNDWATER RECHARGE IN CITY WELLS 10, 11 & 12	0	0	0	0	0	0	0	0	0	0	0	0	0	SEE NOTE 4
9	NET DIVERSION FROM AVAILABLE FLOW TO TATE	240	259	371	909	764	988	904	777	610	765	606	452	7,645	LINE 6-7A-8
BOULLIQUIN BOX															
10	TRANSFER OF MC WTR TO BEAR VALLEY HIGHLINE [Boullouin Box to Highline]	0	0	0	0	0	0	0	0	0	0	0	0	0	SEE NOTE 5
11	TRANSFER OF SAR WATER TO ZANJA [Boullouin Box to Zanja, Weir Records #1]	0	0	3	0	0	4	3	1	0	4	1	0	16	SEE NOTE 5
12	SAN BERN VALLEY MWD TATE PUMP STATION [Delivery line 60]	0	0	0	0	0	0	0	0	0	0	0	0	0	SEE NOTE 6
13	SAN BERN VALLEY MWD UNGER LANE TURNOUT [Unger Lane to Zanja-Crafton, SAR, Line 56]	0	0	0	0	0	0	0	0	0	0	0	0	0	SEE NOTE 6
CRAFTON WATER COMPANY CANAL															
14	INFLOW TO CRAFTON CANAL FROM ZANJA [SBVNMWD Zanja West]	0	1	92	319	267	267	184	215	205	191	157	31	1,929	SEE NOTE 7
15	LESS GROUNDWATER RECHARGE HILL WELL & KING ST. SHAFT	0	0	0	0	0	0	0	0	0	0	0	0	0	SEE NOTE 8
16	NET DIVERSION FROM AVAILABLE FLOW TO CRAFTON	0	1	92	319	267	267	184	215	205	191	157	31	1,929	LINE 14-15
17	TOTAL FLOW DIVERTED INCLUDING UPPER MILL CREEK WELLS	240	260	460	1,228	1,031	1,251	1,085	991	815	952	762	483	9,558	LINE 5+9+10-11 -12-13+16
DEDUCT UPPER MILL CREEK WELLS															
18	CITY OF REDLANDS MILL CREEK NO. 1 REC. NO. 3601282	0	0	0	0	0	0	0	0	0	0	0	0	0	SEE NOTE 9
19	CITY OF REDLANDS MILL CREEK NO. 2 REC. NO. 3601285	201	162	173	239	197	155	165	103	160	206	176	159	2,096	SEE NOTE 9
20	CITY OF REDLANDS MILL CREEK NO. 4 REC. NO. 3601288	107	90	65	33	0	0	109	71	115	96	89	89	775	SEE NOTE 9
21	CITY OF REDLANDS MILL CREEK NO.0-A REC. NO. 3602351	0	0	0	0	0	0	0	0	0	0	0	0	0	SEE NOTE 9
22	CITY OF REDLANDS MILL CREEK NO.2-A REC. NO. 3603045	0	0	0	0	0	0	0	0	0	0	0	0	0	SEE NOTE 9
23	TOTAL UPPER MILL CREEK WELL PRODUCTION	308	252	238	272	197	155	165	212	231	321	272	248	2,871	LINE 18+19 +20+21+22
24	TOTAL MILL CREEK STREAM DIVERSION AS VERIFIED	0	8	222	956	834	1,096	920	779	584	631	490	235	6,755	LINE 17-23

NOTES

- U.S.G.S. UNPUBLISHED RECORDS OF MILL CREEK FLOWS
- YUCAIPA PIPELINE TO YUCAIPA OPERATIONS RECORDS (SAN BERNARDINO VALLEY MUNICIPAL WATER DISTRICT Delivery Mill Creek)
- TATE FILTER PLANT OPERATIONS RECORDS (CITY OF REDLANDS)
- METERED RECHARGE IN WELLS NUMBER 10, 11 AND 12 (RECORDATION NUMBERS 3601291, 3601292 & 3601293 RESPECTIVELY, CITY OF REDLANDS)
- BOULLIQUIN BOX CONNECTS BEAR VALLEY HIGHLINE AND THE ZANJA (SAN BERNARDINO VALLEY MWD & BEAR VALLEY MUTUAL WATER COMPANY)
- SAN BERNARDINO VALLEY MUNICIPAL WATER DISTRICT COMPLETED THE TATE PUMP STATION.
- STATE WATER PROJECT OR SANTA ANA RIVER WATER CAN BE DELIVERED TO MILL CREEK FACILITIES. CRAFTON CANAL DIVERTS FROM THE ZANJA (SAN BERNARDINO VALLEY MUNICIPAL WATER DISTRICT Weir Records for Zanja West)
- GROUNDWATER RECHARGE IN HILL WELL AND KING STREET SHAFT (CRAFTON WATER COMPANY)
- METERED PRODUCTION FROM WELLS IN UPPER MILL CREEK. WELLS PUMP DIRECTLY INTO POWER CANALS. SURFACE DIVERSIONS AND WELL EXTRACTIONS ARE COMMINGLED (CITY OF REDLANDS)

TABLE NO. 5

MILL CREEK
VERIFICATIONS OF EXTRACTIONS
FOR CALENDAR YEAR 2009

LINE NO.	LOCATION OF MEASUREMENT	JAN	FEB	MAR	APR	MAY	JUN	JUL	AUG	SEP	OCT	NOV	DEC	TOTAL	REMARKS
1	MILL CREEK NEAR YUCAIPA STREAMFLOW	568	417	601	208	799	764	533	522	456	471	447	321	6,107	SEE NOTE 1
2	MILL CREEK NEAR YUCAIPA POWER CANALS [11052500]							Station Discontinued							SEE NOTE 1
3	MILL CREEK NEAR YUCAIPA COMBINED FLOW	568	417	601	208	799	764	533	522	456	471	447	321	6,107	SEE NOTE 1
4	TOTAL FLOW AVAILABLE FOR DIVERSION							Station Discontinued							LINE 3
DIVERSIONS															
5	MILL CREEK NO. 2 & 3 POWERHOUSE AFTERBAY													0	SEE NOTE 2
	DIVERSION TO YUCAIPA; "Total Mill Creek Water" Ln 50x														
CITY OF REDLANDS TATE FILTER PLANT															
6	TATE FILTER PLANT [HTWTP Effluent]	539	100	194	44	434	732	562	733	887	871	899	488	6,483	SEE NOTE 3
7	LESS FILTER BACK & SURF WASH WATER RETURNED TO ZANJA	9	0	6	23	11	0	10	60	0	0	0	0	119	SEE NOTE 3
7A	RETURN TO MILL CREEK FROM TATE TREATMENT PLANT	0	0	0	0	0	0	0	0	0	0	0	0	0	SEE NOTE 4
8	LESS GROUNDWATER RECHARGE IN CITY WELLS 10, 11 & 12	530	100	188	21	423	732	552	673	887	871	899	488	6,364	LINE 6-7A-8
	NET DIVERSION FROM AVAILABLE FLOW TO TATE														
BOULLIQUON BOX															
9	TRANSFER OF MC WTR TO BEAR VALLEY HIGHLINE [Boulliou Box to Highline]	0	0	0	0	0	0	0	0	0	0	0	0	0	SEE NOTE 5
10	TRANSFER OF SAR WATER TO ZANJA [Boulliou Box to Zanja, Weir Records #1]	0	0	0	0	0	0	0	0	0	0	365	15	380	SEE NOTE 5
11	SAN BERN VALLEY MWD TATE PUMP STATION [Delivery line 60 61x]	0	0	0	0	0	0	14	55	332	173	267	158	999	SEE NOTE 6
12	SAN BERN VALLEY MWD UNGER LANE TURNOUT [Unger Lane to Zanja-Crafton, SAR, Line 56]	0	0	102	62	60	81	260	135	164	173	74	25	1,136	SEE NOTE 6
CRAFTON WATER COMPANY CANAL															
13	INFLOW TO CRAFTON CANAL FROM ZANJA [SBV/MWD Zanja West]	43	16	101	69	195	0	208	222	254	233	160	74	1,575	SEE NOTE 7
14	LESS GROUNDWATER RECHARGE HILL WELL & KING ST. SHAFT	0	0	0	0	0	0	0	0	0	0	0	0	0	SEE NOTE 8
15	NET DIVERSION FROM AVAILABLE FLOW TO CRAFTON	43	16	101	69	195	0	208	222	254	233	160	74	1,575	LINE 14-15
16	TOTAL FLOW DIVERTED INCLUDING UPPER MILL CREEK WELLS	573	116	187	27	558	651	486	705	645	758	353	364	5,424	LINE 5+9+10-11 -12-13+16
DUCT UPPER MILL CREEK WELLS															
18	CITY OF REDLANDS MILL CREEK NO. 1 REC. NO. 3601282	0	0	0	0	0	0	0	0	0	0	0	0	0	SEE NOTE 9
19	CITY OF REDLANDS MILL CREEK NO. 2 REC. NO. 3601285	135	137	147	111	89	0	0	147	188	111	158	176	1,399	SEE NOTE 9
20	CITY OF REDLANDS MILL CREEK NO. 4 REC. NO. 3601288	81	67	38	18	72	75	92	43	125	56	64	84	816	SEE NOTE 9
21	CITY OF REDLANDS MILL CREEK NO. 0-A REC. NO. 3602351	0	0	0	0	0	0	0	0	0	0	0	0	0	SEE NOTE 9
22	CITY OF REDLANDS MILL CREEK NO. 2-A REC. NO. 3603045	0	0	0	0	28	125	103	0	0	0	0	0	256	SEE NOTE 9
23	TOTAL UPPER MILL CREEK WELL PRODUCTION	217	204	185	130	189	200	195	190	313	167	222	260	2,471	LINE 18+19 +20+21+22
24	TOTAL MILL CREEK STREAM DIVERSION AS VERIFIED	356	0	2	0	369	451	291	515	332	591	131	105	3,143	LINE 17-23

NOTES

- U.S.G.S. UNPUBLISHED RECORDS OF MILL CREEK FLOWS
- YUCAIPA PIPELINE TO YUCAIPA OPERATIONS RECORDS (SAN BERNARDINO VALLEY MUNICIPAL WATER DISTRICT Delivery Mill Creek)
- TATE FILTER PLANT OPERATIONS RECORDS (CITY OF REDLANDS)
- METERED RECHARGE IN WELLS NUMBER 10, 11 AND 12 (RECORDATION NUMBERS 3601291, 3601292 & 3601293 RESPECTIVELY, CITY OF REDLANDS)
- BOULLIQUON BOX CONNECTS BEAR VALLEY HIGHLINE AND THE ZANJA (SAN BERNARDINO VALLEY MWD & BEAR VALLEY MUTUAL WATER COMPANY)
- SAN BERNARDINO VALLEY MUNICIPAL WATER DISTRICT COMPLETED THE TATE PUMP STATION. STATE WATER PROJECT OF SANTA ANA RIVER WATER CAN BE DELIVERED TO MILL CREEK FACILITIES.
- CRAFTON CANAL DIVERTS FROM THE ZANJA (SAN BERNARDINO VALLEY MUNICIPAL WATER DISTRICT Weir Records for Zanja West)
- Return to Mill Creek from Tate Treatment Plant
- GROUNDWATER RECHARGE IN HILL WELL AND KING STREET SHAFT (CRAFTON WATER COMPANY)
- METERED PRODUCTION FROM WELLS IN UPPER MILL CREEK. WELLS PUMP DIRECTLY INTO POWER CANALS. SURFACE DIVERSIONS AND WELL EXTRACTIONS ARE COMMINGLED (CITY OF REDLANDS)

TABLE NO. 5

MILL CREEK
VERIFICATIONS OF EXTRACTIONS
FOR CALENDAR YEAR 2010

LINE NO.	LOCATION OF MEASUREMENT	JAN	FEB	MAR	APR	MAY	JUN	JUL	AUG	SEP	OCT	NOV	DEC	TOTAL	REMARKS
1	MILL CREEK NEAR YUCAIPA STREAMFLOW	199	493	437	852	707	1,160	1,240	1,030	847	803	650	418	8,836	SEE NOTE 1
2	MILL CREEK NEAR YUCAIPA POWER CANALS [11052500]														SEE NOTE 1
3	MILL CREEK NEAR YUCAIPA COMBINED FLOW														SEE NOTE 1
4	TOTAL FLOW AVAILABLE FOR DIVERSION	199	493	437	852	707	1,160	1,240	1,030	847	803	650	418	8,836	LINE 3
DIVERSIONS															
5	MILL CREEK NO. 2 & 3 POWERHOUSE AFTERBAY	0	0	0	0	0	0	0	0	0	0	0	0	0	SEE NOTE 2
	DIVERSION TO YUCAIPA: "Total Mill Creek Water " Ln 50x														
6	CITY OF REDLANDS TATE FILTER PLANT	211	98	0	332	360	886	1,135	1,068	1,057	931	688	238	7,004	SEE NOTE 3
7	TATE FILTER PLANT [HTWTP Effluent]														SEE NOTE 3
7A	LESS FILTER BACK & SURF WASH WATER RETURNED TO ZANJA	0	20	4	37	15	3	1	3	0	2	6	1	92	
8	RETURN TO MILL CREEK FROM TATE TREATMENT PLANT	0	0	0	0	0	0	0	0	0	0	0	0	0	
9	LESS GROUNDWATER RECHARGE IN CITY WELLS 10, 11 & 12	211	78	(4)	295	345	883	1,134	1,065	1,057	929	682	237	6,912	SEE NOTE 4
9	NET DIVERSION FROM AVAILABLE FLOW TO TATE														LINE 6-7A-8
BOULLIQUIN BOX															
10	TRANSFER OF MC WTR TO BEAR VALLEY HIGHLINE [BV Highline to Boulliquin Box]	0	0	0	0	0	0	0	0	0	0	0	0	0	SEE NOTE 5
11	TRANSFER OF SAR WATER TO ZANJA [Weir Records #1, Boulliquin Box to Zanja]	0	0	0	24	0	0	0	47	0	0	0	33	104	SEE NOTE 5
12	SAN BERN VALLEY MWD TATE PUMP STATION [Delivery line 60]	40	0	0	0	0	0	0	47	0	0	0	0	87	SEE NOTE 6
13	SAN BERN VALLEY MWD UNGER LANE TURNOUT [Unger Lane to Zanja-Crafton, SAR, Line 56]	0	0	40	0	53	35	0	46	106	0	0	0	280	SEE NOTE 6
CRAFTON WATER COMPANY CANAL															
14	INFLOW TO CRAFTON CANAL FROM ZANJA [SBVMWD Weir Record #1, Zanja West]	30	0	53	233	254	314	359	372	328	0	0	0	1,943	SEE NOTE 7
15	LESS GROUNDWATER RECHARGE HILL WELL & KING ST. SHAFT	0	0	0	0	0	0	0	0	0	0	0	0	0	SEE NOTE 8
16	NET DIVERSION FROM AVAILABLE FLOW TO CRAFTON	30	0	53	233	254	314	359	372	328	0	0	0	1,943	LINE 14-15
17	TOTAL FLOW DIVERTED INCLUDING UPPER MILL CREEK WELLS	201	78	9	504	546	1,162	1,493	1,297	1,279	929	682	204	8,384	LINE 5+9+10-11 -12-13+16
DEDUCT UPPER MILL CREEK WELLS															
18	CITY OF REDLANDS MILL CREEK NO. 1 REC. NO. 3601282	0	0	0	0	0	0	0	0	0	0	0	0	0	SEE NOTE 9
19	CITY OF REDLANDS MILL CREEK NO. 2 REC. NO. 3601285	135	137	147	111	89	0	0	147	188	111	158	176	1,399	SEE NOTE 9
20	CITY OF REDLANDS MILL CREEK NO. 4 REC. NO. 3601288	81	67	38	18	72	75	92	43	125	56	64	84	816	SEE NOTE 9
21	CITY OF REDLANDS MILL CREEK NO.0-A REC. NO. 3602351	0	0	0	0	0	0	0	0	0	0	0	0	0	SEE NOTE 9
22	CITY OF REDLANDS MILL CREEK NO.2-A REC. NO. 3603045	0	0	0	0	28	125	103	0	0	0	0	0	256	SEE NOTE 9
23	TOTAL UPPER MILL CREEK WELL PRODUCTION	217	204	185	130	189	200	195	190	313	167	222	260	2,471	LINE 18+19 +20+21+22
24	TOTAL MILL CREEK STREAM DIVERSION AS VERIFIED	0	0	0	374	357	962	1,298	1,107	966	762	460	0	6,286	LINE 17-23

NOTES

- U.S.G.S. UNPUBLISHED RECORDS OF MILL CREEK FLOWS
- YUCAIPA PIPELINE TO YUCAIPA OPERATIONS RECORDS (SAN BERNARDINO VALLEY MUNICIPAL WATER DISTRICT Delivery Mill Creek)
- TATE FILTER PLANT OPERATIONS RECORDS (CITY OF REDLANDS)
- METERED RECHARGE IN WELLS NUMBER 10, 11 AND 12 (RECORDATION NUMBERS 3601291, 3601292 & 3601293 RESPECTIVELY, CITY OF REDLANDS)
- BOULLIQUIN BOX CONNECTS BEAR VALLEY HIGHLINE AND THE ZANJA (SAN BERNARDINO VALLEY MWD & BEAR VALLEY MUTUAL WATER COMPANY)

NOTES

- SAN BERNARDINO VALLEY MUNICIPAL WATER DISTRICT COMPLETED THE TATE PUMP STATION. STATE WATER PROJECT OR SANTA ANA RIVER WATER CAN BE DELIVERED TO MILL CREEK FACILITIES.
- CRAFTON CANAL DIVERTS FROM THE ZANJA (SAN BERNARDINO VALLEY MUNICIPAL WATER DISTRICT Weir Records for Zanja West)
- Return to Mill Creek from Tate Treatment Plant
- METERED PRODUCTION FROM HILL WELL AND KING STREET SHAFT (CRAFTON WATER COMPANY) INTO POWER CANALS. SURFACE DIVERSIONS AND WELL EXTRACTIONS ARE COMMINGLED (CITY OF REDLANDS)

Watermaster estimate 07/20/11

TABLE NO. 5

MILL CREEK
VERIFICATIONS OF EXTRACTIONS
FOR CALENDAR YEAR 2011

LINE NO.	LOCATION OF MEASUREMENT	JAN	FEB	MAR	APR	MAY	JUN	JUL	AUG	SEP	OCT	NOV	DEC	TOTAL	REMARKS
1	MILL CREEK NEAR YUCAIPA STREAMFLOW	399	955	1,293	1,006	1,281	1,246	1,155	941	890	509	0	640	10,315	SEE NOTE 1
2	MILL CREEK NEAR YUCAIPA POWER CANALS [11052500]						Station Discontinued								SEE NOTE 1
3	MILL CREEK NEAR YUCAIPA COMBINED FLOW	399	955	1,293	1,006	1,281	1,246	1,155	941	890	509	0	640	10,315	SEE NOTE 1
4	TOTAL FLOW AVAILABLE FOR DIVERSION						Station Discontinued								LINE 3
DIVERSIONS															
5	MILL CREEK NO. 2 & 3 POWERHOUSE AFTERBAY	0	0	0	0	0	0	0	0	0	0	0	0	0	SEE NOTE 2
	DIVERSION TO YUCAIPA: "Total Mill Creek Water" Ln 50x														
CITY OF REDLANDS- TATE FILTER PLANT															
6	TATE FILTER PLANT [HTWTP Effluent]	0	170	749	685	1,062	993	1,025	660	837	464	303	554	7,502	SEE NOTE 3
7	LESS FILTER BACK & SURF WASH WATER RETURNED TO ZANJA	0	0	0	0	0	0	0	0	0	0	0	0	0	SEE NOTE 3
7A	RETURN TO MILL CREEK FROM TATE TREATMENT PLANT	0	0	0	0	0	0	0	0	0	0	0	0	0	
8	LESS GROUNDWATER RECHARGE IN CITY WELLS 10, 11 & 12	0	0	0	0	0	0	0	0	0	0	0	0	0	SEE NOTE 4
9	NET DIVERSION FROM AVAILABLE FLOW TO TATE	0	170	749	685	1,062	993	1,025	660	837	464	303	554	7,502	LINE 6-7A-8
BOULLIOUN BOX															
10	TRANSFER OF MC WTR TO BEAR VALLEY HIGHLINE [BV Highline to Boulloun Box]	0	0	0	0	0	0	0	0	0	0	0	0	0	SEE NOTE 5
11	TRANSFER OF SAR WATER TO ZANJA [Weir Records #1, Boulloun Box to Zanja]	0	0	0	0	0	0	0	0	0	0	0	0	0	SEE NOTE 5
12	SAN BERN VALLEY MWD TATE PUMP STATION [Delivery line 60]	0	0	0	0	0	0	53	133	117	0	0	0	303	SEE NOTE 6
13	SAN BERN VALLEY MWD UNGER LANE TURNOUT [Unger Lane to Zanja-Crafton, SAR, Line 56]	0	0	0	0	0	0	0	33	25	40	39	22	275	SEE NOTE 6
CRAFTON WATER COMPANY CANAL															
14	INFLOW TO CRAFTON CANAL FROM ZANJA [SBVMWD Weir Record #1, Zanja West]	16	46	0	106	358	341	440	429	388	264	61	253	2,702	SEE NOTE 7
15	LESS GROUNDWATER RECHARGE HILL WELL & KING ST. SHAFT	0	0	0	0	0	0	0	0	0	0	0	0	0	SEE NOTE 8
16	NET DIVERSION FROM AVAILABLE FLOW TO CRAFTON	16	46	0	106	358	341	440	429	388	264	61	253	2,702	LINE 14-15
17	TOTAL FLOW DIVERTED INCLUDING UPPER MILL CREEK WELLS	16	216	749	740	1,355	1,334	1,412	923	1,083	668	325	785	9,626	LINE 5+9+10-11 -12-13+16
DUCT UPPER MILL CREEK WELLS															
18	CITY OF REDLANDS MILL CREEK NO. 1 REC. NO. 3601282	0	0	0	0	0	0	0	0	0	0	0	0	0	SEE NOTE 9
19	CITY OF REDLANDS MILL CREEK NO. 2 REC. NO. 3601285	217	198	213	213	212	212	219	214	209	206	184	106	2,403	SEE NOTE 9
20	CITY OF REDLANDS MILL CREEK NO. 4 REC. NO. 3601288	0	0	0	0	0	0	0	0	0	0	0	0	0	SEE NOTE 9
21	CITY OF REDLANDS MILL CREEK NO.0-A REC. NO. 3602351	0	0	0	0	0	0	0	0	0	0	0	0	0	SEE NOTE 9
22	CITY OF REDLANDS MILL CREEK NO.2-A REC. NO. 3603045	0	0	0	0	0	0	0	0	0	0	0	0	0	SEE NOTE 9
23	TOTAL UPPER MILL CREEK WELL PRODUCTION	217	198	213	213	212	212	219	214	209	206	184	106	2,403	LINE 18-19 +20+21+22
24	TOTAL MILL CREEK STREAM DIVERSION AS VERIFIED	0	18	536	527	1,143	1,122	1,193	709	874	482	141	679	7,424	LINE 17-23

NOTES

- U.S.G.S. UNPUBLISHED RECORDS OF MILL CREEK FLOWS
- YUCAIPA PIPELINE TO YUCAIPA OPERATIONS RECORDS (SAN BERNARDINO VALLEY MUNICIPAL WATER DISTRICT Delivery Mill Creek)
- TATE FILTER PLANT OPERATIONS RECORDS (CITY OF REDLANDS)
- METERED RECHARGE IN WELLS NUMBER 10, 11 AND 12 (RECORDATION NUMBERS 3601291, 3601292 & 3601293 RESPECTIVELY, CITY OF REDLANDS)
- BOULLIOUN BOX CONNECTS BEAR VALLEY HIGHLINE AND THE ZANJA (SAN BERNARDINO VALLEY MWD & BEAR VALLEY MUTUAL WATER COMPANY)

NOTES

- SAN BERNARDINO VALLEY MUNICIPAL WATER DISTRICT COMPLETED THE TATE PUMP STATION.
- STATE WATER PROJECT OR SANTA ANA RIVER WATER CAN BE DELIVERED TO MILL CREEK FACILITIES.
- CRAFTON CANAL DIVERTS FROM THE ZANJA (SAN BERNARDINO VALLEY MUNICIPAL WATER DISTRICT Weir Records for Zanja West)
- Return to Mill Creek from Tate Treatment Plant
- GROUNDWATER RECHARGE IN HILL WELL AND KING STREET SHAFT (CRAFTON WATER COMPANY) METERED PRODUCTION FROM WELLS IN UPPER MILL CREEK. WELLS PUMP DIRECTLY INTO POWER CANALS. SURFACE DIVERSIONS AND WELL EXTRACTIONS ARE COMMINGLED

TABLE NO. 5

MILL CREEK
VERIFICATIONS OF EXTRACTIONS
FOR CALENDAR YEAR 2012

LINE NO.	LOCATION OF MEASUREMENT	JAN	FEB	MAR	APR	MAY	JUN	JUL	AUG	SEP	OCT	NOV	DEC	TOTAL	REMARKS
1	MILL CREEK NEAR YUCAIPA STREAMFLOW	273	619	655	652	639	485	549	158	413	580	536	532	6,091	SEE NOTE 1
2	MILL CREEK NEAR YUCAIPA POWER CANALS [111052500]							Station Discontinued							SEE NOTE 1
3	MILL CREEK NEAR YUCAIPA COMBINED FLOW	273	619	655	652	639	485	549	158	413	580	536	532	6,091	SEE NOTE 1
4	TOTAL FLOW AVAILABLE FOR DIVERSION							Station Discontinued							LINE 3
	<u>DIVERSIONS</u>														
5	MILL CREEK NO. 2 & 3 POWERHOUSE AFTERBAY	0	0	0	0	0	0	0	0	0	0	0	0	0	SEE NOTE 2
	UNDER DIVERSION TO YUCAIPA; "Total Mill Creek Water" Ln 50x														
	<u>CITY OF REDLANDS TATE FILTER PLANT</u>														
6	TATE FILTER PLANT [HTWTP Effluent]	147	733	654	538	620	951	841	634	697	845	703	634	7,997	SEE NOTE 3
7	LESS FILTER BACK & SURF WASH WATER RETURNED TO ZANJA	0	0	0	0	0	0	0	0	0	0	0	0	0	SEE NOTE 3
7A	RETURN TO MILL CREEK FROM TATE TREATMENT PLANT	0	0	0	0	0	0	0	0	0	0	0	0	0	
8	LESS GROUNDWATER RECHARGE IN CITY WELLS 10, 11 & 12	0	0	0	0	0	0	0	0	0	0	0	0	0	SEE NOTE 4
9	NET DIVERSION FROM AVAILABLE FLOW TO TATE	147	733	654	538	620	951	841	634	697	845	703	634	7,997	LINE 6-7A-8
	<u>BOULLIQUON BOX</u>														
10	TRANSFER OF MC WTR TO BEAR VALLEY HIGHLINE [BV Highline to Boulliou Box]	0	0	0	0	0	0	0	0	0	0	0	0	0	SEE NOTE 5
11	TRANSFER OF SAR WATER TO ZANJA [Weir Records #1, Boulliou Box to Zanja]	0	0	0	0	26	47	24	26	32	21	6	0	182	SEE NOTE 5
12	SAN BERN VALLEY MWD TATE PUMP STATION [Delivery line 60]	0	0	0	0	232	142	123	367	305	0	0	0	1,169	SEE NOTE 6
13	SAN BERN VALLEY MWD UNGER LANE TURNOUT [Unger Lane to Zanja-Crafton, SAR, Line 56]	0	0	0	2	67	186	243	366	225	277	218	57	1,641	SEE NOTE 6
	<u>CRAFTON WATER COMPANY CANAL</u>														
14	INFLOW TO CRAFTON CANAL FROM ZANJA [SBVMWD Weir Record #1, Zanja West]	233	167	63	189	297	358	421	464	400	403	303	92	3,390	SEE NOTE 7
15	LESS GROUNDWATER RECHARGE HILL WELL & KING ST. SHAFT	0	0	0	0	0	0	0	0	0	0	0	0	0	SEE NOTE 8
16	NET DIVERSION FROM AVAILABLE FLOW TO CRAFTON	233	167	63	189	297	358	421	464	400	403	303	92	3,390	LINE 14-15
17	TOTAL FLOW DIVERTED INCLUDING UPPER MILL CREEK WELLS	380	900	717	725	592	934	872	339	535	950	782	669	8,395	LINE 5+9+10-11 -12-13+16
	<u>DUCT UPPER MILL CREEK WELLS</u>														
18	CITY OF REDLANDS MILL CREEK NO. 1 REC. NO. 3601282	0	0	0	0	0	0	0	0	0	0	0	0	0	SEE NOTE 9
19	CITY OF REDLANDS MILL CREEK NO. 2 REC. NO. 3601285	212	198	235	212	198	50	177	212	212	219	209	215	2,349	SEE NOTE 9
20	CITY OF REDLANDS MILL CREEK NO. 4 REC. NO. 3601288	0	0	0	12	0	0	5	0	83	109	99	79	387	SEE NOTE 9
21	CITY OF REDLANDS MILL CREEK NO. 0-A REC. NO. 3602351	0	0	0	0	0	0	0	0	0	0	0	0	0	SEE NOTE 9
22	CITY OF REDLANDS MILL CREEK NO. 2-A REC. NO. 3603045	0	0	0	0	0	0	0	0	0	0	0	0	0	SEE NOTE 9
23	TOTAL UPPER MILL CREEK WELL PRODUCTION	212	198	235	224	198	50	182	212	295	328	308	294	2,736	LINE 18+19 +20+21+22
24	TOTAL MILL CREEK STREAM DIVERSION AS VERIFIED	168	702	482	501	394	884	690	127	240	622	474	375	5,659	LINE 17-23

NOTES

- 1 U.S.G.S. UNPUBLISHED RECORDS OF MILL CREEK FLOWS
- 2 YUCAIPA PIPELINE TO YUCAIPA OPERATIONS RECORDS (SAN BERNARDINO VALLEY MUNICIPAL WATER DISTRICT Delivery Mill Creek)
- 3 TATE FILTER PLANT OPERATIONS RECORDS (CITY OF REDLANDS)
- 4 METERED RECHARGE IN WELLS NUMBER 10, 11 AND 12 (RECORDATION NUMBERS 3601291, 3601292 & 3601293 RESPECTIVELY, CITY OF REDLANDS)
- 5 BOULLIQUON BOX CONNECTS BEAR VALLEY HIGHLINE AND THE ZANJA (SAN BERNARDINO VALLEY MWD & BEAR VALLEY MUTUAL WATER COMPANY)

NOTES

- 6 SAN BERNARDINO VALLEY MUNICIPAL WATER DISTRICT COMPLETED THE TATE PUMP STATION. STATE WATER PROJECT OR SANTA ANA RIVER WATER CAN BE DELIVERED TO MILL CREEK FACILITIES.
- 7 CRAFTON CANAL DIVERTS FROM THE ZANJA (SAN BERNARDINO VALLEY MUNICIPAL WATER DISTRICT Weir Records for Zanja West)
- 7A Return to Mill Creek from Tate Treatment Plant
- 8 GROUNDWATER RECHARGE IN HILL WELL AND KING STREET SHAFT (CRAFTON WATER COMPANY)
- 9 METERED PRODUCTION FROM WELLS IN UPPER MILL CREEK. WELLS PUMP DIRECTLY INTO POWER CANALS. SURFACE DIVERSIONS AND WELL EXTRACTIONS ARE COMMINGLED (CITY OF REDLANDS)

TABLE NO. 6

SANTA ANA RIVER VERIFICATION OF EXTRACTIONS FOR
CALENDAR YEARS 2008-2012

TABLE NO. 6

SANTA ANA RIVER
VERIFICATIONS OF EXTRACTIONS
FOR CALENDAR YEAR 2008

LINE NO.	LOCATION OF MEASUREMENT	JAN	FEB	MAR	APR	MAY	JUN	JUL	AUG	SEP	OCT	NOV	DEC	TOTAL	REMARKS
1	SANTA ANA RIVER NEAR MENTONE STREAMFLOW [11051500]	279	1,240	1,280	7,340	3,940	2,060	908	442	631	386	218	302	19,026	SEE NOTE 1
2	SANTA ANA RIVER NEAR MENTONE POWER CANALS [Ln 3 - Ln 1]	1,051	1,320	2,140	1,600	1,150	640	672	758	559	904	982	1,288	13,064	SEE NOTE 1
3	SANTA ANA RIVER NEAR MENTONE COMBINED FLOW [11051501]	1,330	2,560	3,420	8,940	5,090	2,700	1,580	1,200	1,190	1,290	1,200	1,590	32,090	SEE NOTE 1
4	REDLANDS WATER COMPANY REDLANDS TUNNEL [SBWVCD data]	36	42	79	83	1	162	46	34	28	31	26	57	625	SEE NOTE 2
5	TOTAL FLOW AVAILABLE FOR DIVERSION	1,366	2,602	3,499	9,023	5,091	2,862	1,626	1,234	1,218	1,321	1,226	1,647	32,715	LINE 3+4
DIVERSIONS															
EAST HIGHLAND CANAL															
6	EAST HIGHLAND WEIR (SBWVCD EDWARDS)	7	8	16	36	27	36	36	36	36	36	36	18	328	SEE NOTE 3
7	LESS SPREADING [from EVWD]							Not in Service							SEE NOTE 3
8	NET EAST HIGHLAND CANAL DIVERSIONS	7	8	16	36	27	36	36	36	36	36	36	18	328	LINE 6-7
NORTH FORK DIVERSION															
9	NORTH FORK WEIR [SBWVCD data]	308	0	130	441	473	460	482	475	436	474	463	402	4,544	SEE NOTE 3
10	LESS SPREADING FROM CANAL AT CITY CR. & SAND CYN. [from EVWD]	0	0	76	65	246	98	134	91	22	17	21	12	782	SEE NOTE 3
11	NET NORTH FORK DIVERSION	308	0	54	376	227	362	348	384	414	457	442	390	3,762	LINE 9-10
REDLANDS CANAL															
12	CORPS OF ENGINEERS & SO. CAL. EDISON CO. USE [estimated]	0	0	0	0	0	0	0	0	0	0	0	0	0	SEE NOTE 4
12A	SBWVWD DIVERSIONS AT MORTON CANYON CONNECTION	575	255	1,099	1,461	1,029	1,306	673	349	697	785	365	1,082	9,676	SEE NOTE 5
13	REDLANDS CANAL WEIR AT SANDBOX [SBWVWD Redlands Aqueduct Weir]	249	81	209	157	94	55	0	75	27	36	114	215	1,312	
14	LESS SPREADING MENTONE RES., JUDSON ST., & AIRPORT	326	174	890	1,304	935	1,251	673	274	670	749	251	867	8,364	LINE 12+12A +13-14
15	NET REDLANDS CANAL DIVERSION	79	42	4	0	89	325	378	324	369	366	286	286	2,548	SEE NOTE 6
16	BEAR VALLEY HIGHLINE [SBWVWD Bear Valley High Line inlet meter]	0	0	0	0	0	0	0	0	0	0	0	0	0	SEE NOTE 6
17	LESS SPREADING AT MILL CREEK	0	0	0	0	0	0	0	0	0	0	0	0	0	SEE NOTE 6
18	NET BEAR VALLEY HIGHLINE DIVERSION	79	42	4	0	89	325	378	324	369	366	286	286	2,548	LINE 16-17
SAN BERNARDINO VALLEY MWD GREENSPOT PIPELINE															
19	GREENSPOT METER STATION [SBWVWD delivery sum of lines 38-47]	0	0	0	0	0	0	0	0	0	0	0	0	0	SEE NOTE 6
20	LESS SPREADING AT MILL CREEK [SBWVWD delivery line 42]	0	0	0	0	0	0	0	0	0	0	0	0	0	SEE NOTE 6
21	NET GREENSPOT PIPELINE	720	224	964	1,716	1,278	1,974	1,435	1,018	1,489	1,608	1,015	1,561	15,002	LINE 8+11 +15+18+21
22	TOTAL NET DIVERSION FROM AVAILABLE FLOW	0	0	0	0	30	30	31	30	30	31	0	0	182	SEE NOTE 7
23	DEDUCT SANTA ANA WELLS	0	0	0	0	0	0	0	0	0	0	0	0	0	SEE NOTE 7
24	SANTA ANA WELL NO. 1 RECORDATION NO. 3600021 [SBWVCD data]	0	0	0	0	0	0	0	0	0	0	0	0	0	SEE NOTE 7
25	SANTA ANA WELL NO. 2 RECORDATION NO. 3600022	0	0	0	0	0	0	0	0	0	0	0	0	0	SEE NOTE 7
25	TOTAL PUMPED WATER	0	0	0	0	0	30	31	30	30	31	0	0	182	LINE 23+24
26	TOTAL SANTA ANA RIVER STREAM DIVERSION AS VERIFIED	720	224	964	1,716	1,248	1,944	1,404	988	1,459	1,577	1,015	1,561	14,820	LINE 22-25

NOTES

- U.S.G.S. RECORDS OF SANTA ANA RIVER FLOWS
- REDLANDS WATER COMPANY TUNNEL IS AN INFILTRATION GALLERY WHICH INTERFLDS SANTA ANA RIVER UNDERFLOW. DATA FROM SAN BERNARDINO VALLEY WATER CONSERVATION DISTRICT. FLOW SHOWN INCLUDES LINE NO. 12. OF THIS TABLE.
- EAST HIGHLAND CANAL AND NORTH FORK CANAL DIVERT WATER TO AGRICULTURAL USE MUNICIPAL USE AND LIMITED SPREADING. DATA FROM EAST VALLEY WATER DISTRICT. THE CORPS OF ENGINEERS AND SOUTHERN CALIFORNIA EDISON COMPANY DIVERT WATER FROM REDLANDS TUNNEL UPSTREAM OF THE TUNNELS CONFLUENCE WITH REDLANDS CANAL WHICH IS UPSTREAM OF THE REDLANDS CANAL WEIR.
- STARTING WITH 2008; COUNTY FILING ANNUAL EXTRACTION AMOUNTS; RECORDATION #3603900
- DATA FROM SAN BERNARDINO VALLEY MUNICIPAL WATER DISTRICT RECORDS OF OPERATIONS OF REDLANDS CANAL WEIR AND REDLANDS CANAL.
- DATA FROM SAN BERNARDINO VALLEY MUNICIPAL WATER DISTRICT RECORDS OF OPERATIONS OF BEAR VALLEY HIGHLINE. SAN BERNARDINO VALLEY MUNICIPAL WATER DISTRICT COMPLETED ITS GREENSPOT HIGHLINE PIPELINE IN 1985.
- SANTA ANA NO.1 AND NO. 2 WELLS ARE LOCATED IN UPPER SANTA ANA CANYON AND PUMPED DIRECTLY TO POWER CANALS. DIVERSION OF STREAMFLOW AND WELL EXTRACTIONS ARE COMMINGLED. DATA FROM SAN BERNARDINO VALLEY WATER CONSERVATION DISTRICT.

TABLE NO. 6

SANTA ANA RIVER
VERIFICATIONS OF EXTRACTIONS
FOR CALENDAR YEAR 2009

LINE NO.	LOCATION OF MEASUREMENT	JAN	FEB	MAR	APR	MAY	JUN	JUL	AUG	SEP	OCT	NOV	DEC	TOTAL	REMARKS
1	SANTA ANA RIVER NEAR MENTONE STREAMFLOW [11051500]	475	278	266	280	2,870	454	219	307	291	219	152	256	6,067	SEE NOTE 1
2	SANTA ANA RIVER NEAR MENTONE POWER CANALS [Ln 3 - Ln 1]	1,625	1,912	2,754	2,160	1,620	1,266	699	550	423	755	918	934	15,616	SEE NOTE 1
3	SANTA ANA RIVER NEAR MENTONE COMBINED FLOW [11051501]	2,100	2,190	3,020	2,440	4,490	1,720	918	857	714	974	1,070	1,190	21,683	SEE NOTE 1
4	REDLANDS WATER COMPANY REDLANDS TUNNEL [SBVWCD data]	89	59	78	76	83	84	41	25	21	21	22	53	630	SEE NOTE 2
5	TOTAL FLOW AVAILABLE FOR DIVERSION	2,189	2,249	3,098	2,516	4,573	1,804	959	882	735	995	1,092	1,243	22,313	LINE 3-4
DIVERSIONS															
EAST HIGHLAND CANAL															
6	EAST HIGHLAND WEIR [SBVWCD EDWARDS]	27	7	27	36	36	36	36	36	36	37	37	18	369	SEE NOTE 3
7	LESS SPREADING [from EVWVD]						Not in Service								SEE NOTE 3
8	NET EAST HIGHLAND CANAL DIVERSIONS	27	7	27	36	36	36	36	36	36	37	37	18	369	LINE 6-7
NORTH FORK DIVERSION															
9	NORTH FORK WEIR [SBVWCD data]	403	142	234	359	423	414	432	449	437	448	434	397	4,572	SEE NOTE 3
10	LESS SPREADING FROM CANAL AT CITY CR. & SAND CYN. [from EVWVD]	0	9	10	54	0	0	0	0	0	0	3	3	79	SEE NOTE 3
11	NET NORTH FORK DIVERSION	403	133	224	305	423	414	432	449	437	448	431	394	4,493	LINE 9-10
REDLANDS CANAL															
12	CORPS OF ENGINEERS & SO. CAL. EDISON CO. USE [estimated]	0	0	0	0	0	0	0	0	0	0	0	0	0	SEE NOTE 4
12A	SBVMWD DIVERSIONS AT MORTON CANYON CONNECTION	928	669	1,104	957	857	603	504	425	330	15	1,306	297	7,995	SEE NOTE 5
13	REDLANDS CANAL WEIR AT SANDBOX [SBVMWD Redlands Aqueduct Weir #2]	439	203	282	58	18	51	4	10	53	47	109	162	1,436	SEE NOTE 5
14	LESS SPREADING MENTONE RES., JUDSON ST., & AIRPORT	489	466	822	899	839	552	500	415	277	(32)	1,197	135	6,559	LINE 12+12A +13-14
15	NET REDLANDS CANAL DIVERSION	85	0	0	0	85	278	327	348	336	294	157	83	1,993	SEE NOTE 6
16	BEAR VALLEY HIGHLINE	85	0	0	0	85	278	327	348	336	294	157	83	1,993	SEE NOTE 6
17	BEAR VALLEY HIGHLINE [SBVMWD Bear Valley High Line inlet meter]	0	0	0	0	0	0	0	0	0	0	0	0	0	SEE NOTE 6
18	LESS SPREADING AT MILL CREEK	85	0	0	0	85	278	327	348	336	294	157	83	1,993	SEE NOTE 6
19	NET BEAR VALLEY HIGHLINE DIVERSION	0	0	0	0	0	0	0	0	0	0	0	0	0	LINE 16-17
SAN BERNARDINO VALLEY MWD GREENSPOT PIPELINE															
19	GREENSPOT METER STATION [SBVMWD delivery sum of lines 38-47 - Bear Valley Highline]	0	0	0	0	0	0	0	0	0	0	0	0	0	SEE NOTE 6
20	LESS SPREADING AT MILL CREEK [SBVMWD delivery line 42]	0	0	0	0	0	0	0	0	0	0	0	0	0	SEE NOTE 6
21	NET GREENSPOT PIPELINE	0	0	0	0	0	0	0	0	0	0	0	0	0	LINE 19-20
22	TOTAL NET DIVERSION FROM AVAILABLE FLOW	1,004	606	1,073	1,240	1,383	1,280	1,295	1,248	1,086	747	1,822	630	13,414	LINE 8+11 +15+18+21
DEDUCT SANTA ANA WELLS															
23	SANTA ANA WELL NO. 1 RECORDATION NO. 3600021 [SBVWCD data]	0	0	0	0	0	0	0	0	0	0	0	0	0	SEE NOTE 7
24	SANTA ANA WELL NO. 2 RECORDATION NO. 3600022	0	0	0	0	0	0	0	0	0	0	0	0	0	SEE NOTE 7
25	TOTAL PUMPED WATER	0	0	0	0	0	0	0	0	0	0	0	0	0	LINE 23+24
26	TOTAL SANTA ANA RIVER STREAM DIVERSION AS VERIFIED	1,004	606	1,073	1,240	1,383	1,280	1,295	1,248	1,086	747	1,822	630	13,414	LINE 22-25

NOTES

- U.S.G.S. RECORDS OF SANTA ANA RIVER FLOWS
- REDLANDS WATER COMPANY TUNNEL IS AN INFILTRATION GALLERY WHICH INTERCEPTS SANTA ANA RIVER UNDERFLOW. DATA FROM SAN BERNARDINO VALLEY WATER CONSERVATION DISTRICT. FLOW SHOWN INCLUDES LINE NO. 12. OF THIS TABLE.
- EAST HIGHLAND CANAL AND NORTH FORK CANAL DIVERT WATER TO AGRICULTURAL USE MUNICIPAL USE AND LIMITED SPREADING. DATA FROM EAST VALLEY WATER DISTRICT. THE CORPS OF ENGINEERS AND SOUTHERN CALIFORNIA EDISON COMPANY DIVERT WATER FROM REDLANDS TUNNEL UPSTREAM OF THE TUNNELS CONFLUENCE WITH REDLANDS CANAL WHICH IS UPSTREAM OF THE REDLANDS CANAL WEIR. **STARTING WITH 2008, COUNTY FILING ANNUAL EXTRACTION AMOUNTS, RECORDATION #3603900**
- DATA FROM SAN BERNARDINO VALLEY MUNICIPAL WATER DISTRICT RECORDS OF OPERATIONS OF REDLANDS CANAL WEIR AND REDLANDS CANAL.
- DATA FROM SAN BERNARDINO VALLEY MUNICIPAL WATER DISTRICT RECORDS OF OPERATIONS OF BEAR VALLEY HIGHLINE. SAN BERNARDINO VALLEY MUNICIPAL WATER DISTRICT COMPLETED ITS GREENSPOT HIGHLINE PIPELINE IN 1985.
- SANTA ANA NO. 1 AND NO. 2 WELLS ARE LOCATED IN UPPER SANTA ANA CANYON AND PUMPED DIRECTLY TO POWER CANALS. DIVERSION OF STREAMFLOW AND WELL EXTRACTIONS ARE COMMINGLED. DATA FROM SAN BERNARDINO VALLEY WATER CONSERVATION DISTRICT.

TABLE NO. 6

SANTA ANA RIVER
VERIFICATIONS OF EXTRACTIONS
FOR CALENDAR YEAR 2010

LINE NO.	LOCATION OF MEASUREMENT	JAN	FEB	MAR	APR	MAY	JUN	JUL	AUG	SEP	OCT	NOV	DEC	TOTAL	REMARKS
1	SANTA ANA RIVER NEAR MENTONE STREAMFLOW [11051500]	385	226	214	144	152	181	12,820	7,770	545	380	189	216	22,892	SEE NOTE 1
2	SANTA ANA RIVER NEAR MENTONE POWER CANALS [Ln 3 - Ln 1]	745	387	2,176	3,426	4,258	3,379	2,120	1,520	1,375	1,480	1,041	954	22,861	SEE NOTE 1
3	SANTA ANA RIVER NEAR MENTONE COMBINED FLOW [11051501]	1,100	613	2,390	3,570	4,410	3,560	14,640	9,290	1,920	1,860	1,230	1,170	45,753	SEE NOTE 1
4	REDLANDS WATER COMPANY REDLANDS TUNNEL [SBVMWD data]	81	55	51	51	45	44	24	96	41	20	40	85	633	SEE NOTE 2
5	TOTAL FLOW AVAILABLE FOR DIVERSION	1,181	668	2,441	3,621	4,455	3,604	14,664	9,386	1,961	1,880	1,270	1,255	46,386	LINE 3+4
DIVERSIONS															
EAST HIGHLAND CANAL															
6	EAST HIGHLAND WEIR [SBVMWD EDWARDS]	5	0	12	31	46	41	35	40	36	27	29	0	302	SEE NOTE 3
7	LESS SPREADING [from EVWVD]						Not in Service								SEE NOTE 3
8	NET EAST HIGHLAND CANAL DIVERSIONS	5	0	12	31	46	41	35	40	36	27	29	0	302	LINE 6-7
NORTH FORK DIVERSION															
9	NORTH FORK WEIR [SBVMWD data]	233	45	199	271	358	324	454	358	0	0	0	74	2,316	SEE NOTE 3
10	LESS SPREADING FROM CANAL AT CITY CR. & SAND CYN. [from EVWVD]	0	0	21	0	13	14	0	0	0	0	5	0	53	SEE NOTE 3
11	NET NORTH FORK DIVERSION	233	45	178	271	345	310	454	358	0	0	0	74	2,268	LINE 9-10
REDLANDS CANAL															
12	CORPS OF ENGINEERS & SO. CAL. EDISON CO. USE [estimated]	0	0	0	0	0	0	0	0	0	0	0	0	0	SEE NOTE 4
12A	SBVMWD DIVERSIONS AT MORTON CANYON CONNECTION	322	243	707	964	1,571	1,643	1,259	539	1,160	1,209	845	706	11,168	SEE NOTE 5
13	REDLANDS CANAL WEIR AT SANDBOX [SBVMWD Weir records #2; Redlands Aqueduct Weir]	0	0	0	0	0	0	0	0	0	0	0	0	0	SEE NOTE 5
14	LESS SPREADING MENTONE RES., JUDSON ST., & AIRPORT [Bear Valley records]	322	74	209	282	888	199	38	31	38	291	156	0	2,528	
15	NET REDLANDS CANAL DIVERSION	0	169	498	682	683	1,444	1,221	508	1,122	918	689	706	8,640	LINE 12+12A +13-14
BEAR VALLEY HIGHLINE															
16	BEAR VALLEY HIGHLINE [SBVMWD Bear Valley High Line inlet meter]	48	31	64	209	407	385	370	343	435	413	267	147	3,119	SEE NOTE 6
17	LESS SPREADING AT MILL CREEK	16	0	25	0	0	0	0	0	0	35	4	51	131	SEE NOTE 6
18	NET BEAR VALLEY HIGHLINE DIVERSION	32	31	39	209	407	385	370	343	435	378	263	96	2,988	LINE 16-17
SAN BERNARDINO VALLEY MWD GREENSPOT PIPELINE															
19	GREENSPOT METER STATION [SBVMWD delivery sum of lines 38-47]	0	0	0	0	0	0	0	0	0	0	0	0	0	SEE NOTE 6
20	LESS SPREADING AT MILL CREEK [SBVMWD delivery line 42]	0	0	0	0	0	0	0	0	0	0	0	0	0	SEE NOTE 6
21	NET GREENSPOT PIPELINE	0	0	0	0	0	0	0	0	0	0	0	0	0	LINE 19-20
22	TOTAL NET DIVERSION FROM AVAILABLE FLOW	270	245	727	1,193	1,481	2,180	2,080	1,249	1,593	1,323	981	876	14,198	LINE 8+11 +15+18+21
DEDUCT SANTA ANA WELLS															
23	SANTA ANA WELL NO. 1 RECORDATION NO. 3600021 [SBVMWD data]	0	0	0	0	0	0	0	0	0	0	0	0	0	SEE NOTE 7
24	SANTA ANA WELL NO. 2 RECORDATION NO. 3600022	0	0	0	0	0	0	0	0	0	0	0	0	0	SEE NOTE 7
25	TOTAL PUMPED WATER	0	0	0	0	0	0	0	0	0	0	0	0	0	LINE 23+24
26	TOTAL SANTA ANA RIVER STREAM DIVERSION AS VERIFIED	270	245	727	1,193	1,481	2,180	2,080	1,249	1,593	1,323	981	876	14,198	LINE 22-25

NOTES

- U.S.G.S. RECORDS OF SANTA ANA RIVER FLOWS
 - REDLANDS WATER COMPANY TUNNEL IS AN INFILTRATION GALLERY WHICH INTERCEPTS SANTA ANA RIVER UNDERFLOW. DATA FROM SAN BERNARDINO VALLEY WATER CONSERVATION DISTRICT. FLOW SHOWN INCLUDES LINE NO. 12. OF THIS TABLE.
 - EAST HIGHLAND CANAL AND NORTH FORK CANAL DIVERT WATER TO AGRICULTURAL USE MUNICIPAL USE AND LIMITED SPREADING. DATA FROM EAST VALLEY WATER DISTRICT. THE CORPS OF ENGINEERS AND SOUTHERN CALIFORNIA EDISON COMPANY DIVERT WATER FROM REDLANDS TUNNEL UPSTREAM OF THE TUNNELS CONFLUENCE WITH REDLANDS CANAL WHICH IS UPSTREAM OF THE REDLANDS CANAL WEIR.
 - STARTING WITH 2008, COUNTY FILING ANNUAL EXTRACTION AMOUNTS; RECORDATION #3603900
- NOTES
- DATA FROM SAN BERNARDINO VALLEY MUNICIPAL WATER DISTRICT RECORDS OF OPERATIONS OF REDLANDS CANAL WEIR AND REDLANDS CANAL
 - DATA FROM SAN BERNARDINO VALLEY MUNICIPAL WATER DISTRICT RECORDS OF OPERATIONS OF BEAR VALLEY HIGHLINE. SAN BERNARDINO VALLEY MUNICIPAL WATER DISTRICT COMPLETED ITS GREENSPOT HIGHLINE PIPELINE IN 1985.
 - SANTA ANA NO. 1 AND NO. 2 WELLS ARE LOCATED IN UPPER SANTA ANA CANYON AND PUMPED DIRECTLY TO POWER CANALS. DIVERSION OF STREAFLOW AND WELL EXTRACTIONS ARE COMMINGLED. DATA FROM SAN BERNARDINO VALLEY WATER CONSERVATION DISTRICT.

TABLE NO. 6

SANTA ANA RIVER
VERIFICATIONS OF EXTRACTIIONS
FOR CALENDAR YEAR 2011

LINE NO.	LOCATION OF MEASUREMENT	JAN	FEB	MAR	APR	MAY	JUN	JUL	AUG	SEP	OCT	NOV	DEC	TOTAL	REMARKS
1	SANTA ANA RIVER NEAR MENTONE STREAMFLOW [11051500]	166	6,506	24,954	24,571	9,947	1,712	1,337	1,026	740	869	168	230	72,226	SEE NOTE 1
2	SANTA ANA RIVER NEAR MENTONE POWER CANALS [Ln 3 - Ln 1]	0	0	0	0	1,105	3,638	2,757	2,070	1,874	1,624	2,000	1,930	16,998	SEE NOTE 1
3	SANTA ANA RIVER NEAR MENTONE COMBINED FLOW [11051501]	166	6,506	24,954	24,571	11,052	5,350	4,094	3,096	2,614	2,493	2,168	2,160	89,224	SEE NOTE 1
4	REDLANDS WATER COMPANY REDLANDS TUNNEL [SBVWCD data]													0	SEE NOTE 2
5	TOTAL FLOW AVAILABLE FOR DIVERSION	166	6,506	24,954	24,571	11,052	5,350	4,094	3,096	2,614	2,493	2,168	2,160	89,224	LINE 3+4
DIVERSIONS															
6	EAST HIGHLAND CANAL													390	SEE NOTE 3
7	EAST HIGHLAND WEIR (SBVWCD EDWARDS)													390	SEE NOTE 3
8	LESS SPREADING [from EYWD]													0	LINE 6-7
9	NET EAST HIGHLAND CANAL DIVERSIONS													390	
Annual diversion amount provided by SBVWCD Not in Service															
9	NORTH FORK DIVERSION													3,066	SEE NOTE 3
10	NORTH FORK WEIR [SBVWCD data]													80	SEE NOTE 3
11	LESS SPREADING FROM CANAL AT CITY CR. & SAND CYN. [from EYWD]													2,986	LINE 9-10
12	NET NORTH FORK DIVERSION													3,066	
Annual diversion amount provided by SBVWCD															
12	REDLANDS CANAL													0	SEE NOTE 4
13	CORPS OF ENGINEERS & SO. CAL. EDISON CO. USE Reported as 3603900													0	SEE NOTE 5
14	SBVWCD DIVERSIONS AT MORTON CANYON CONNECTION													11,812	SEE NOTE 5
15	REDLANDS CANAL WEIR AT SANDBOX [SBVWCD Weir records #2, Redlands Aqueduct Weir]	0	224	454	413	1,093	1,617	1,663	1,238	1,099	1,051	1,161	1,358	11,812	SEE NOTE 5
16	LESS SPREADING MENTONE RES., JUDSON ST., & AIRPORT [Bear Valley records]	0	224	454	413	295	379	233	125	162	105	311	320	3,021	
17	NET REDLANDS CANAL DIVERSION	0	0	0	441	798	1,238	1,430	1,113	937	946	850	1,038	8,791	LINE 12+12A +13-14
18	BEAR VALLEY HIGHLINE													1,825	SEE NOTE 6
19	BEAR VALLEY HIGHLINE [SBVWCD Bear Valley High Line inlet meter]	0	0	0	0	113	360	372	398	398	0	184	0	1,825	SEE NOTE 6
20	LESS SPREADING AT MILL CREEK	0	0	0	0	0	0	0	0	0	0	0	0	0	SEE NOTE 6
21	NET BEAR VALLEY HIGHLINE DIVERSION	0	0	0	0	113	360	372	398	398	0	184	0	1,825	LINE 16-17
SAN BERNARDINO VALLEY MWD GREENSPOT PIPELINE															
19	GREENSPOT METER STATION [SBVWCD delivery sum of lines 38-47]	0	0	0	0	0	0	0	0	0	0	0	0	0	SEE NOTE 6
20	LESS SPREADING AT MILL CREEK [SBVWCD delivery line 42]	0	0	0	0	0	0	0	0	0	0	0	0	0	SEE NOTE 6
21	NET GREENSPOT PIPELINE	0	0	0	0	0	0	0	0	0	0	0	0	0	LINE 19-20
22	TOTAL NET DIVERSION FROM AVAILABLE FLOW	0	0	0	441	911	1,598	1,802	1,511	1,335	946	1,034	1,038	13,992	LINE 8+11 +15+18+21
DEDUCT SANTA ANA WELLS															
23	SANTA ANA WELL NO. 1 RECORDATION NO. 3600021 [SBVWCD data]	0	0	0	0	0	0	0	0	0	0	0	0	0	SEE NOTE 7
24	SANTA ANA WELL NO. 2 RECORDATION NO. 3600022	0	0	0	0	0	0	0	0	0	0	0	0	0	SEE NOTE 7
25	TOTAL PUMPED WATER	0	0	0	0	0	0	0	0	0	0	0	0	0	LINE 23+24
26	TOTAL SANTA ANA RIVER STREAM DIVERSION AS VERIFIED	0	0	0	441	911	1,598	1,802	1,511	1,335	946	1,034	1,038	13,992	LINE 22-25

NOTES

- U.S.G.S. RECORDS OF SANTA ANA RIVER FLOWS
- REDLANDS WATER COMPANY TUNNEL IS AN INFILTRATION GALLERY WHICH INTERCEPTS SANTA ANA RIVER UNDERFLOW. DATA FROM SAN BERNARDINO VALLEY WATER CONSERVATION DISTRICT FLOW SHOWN INCLUDES LINE NO. 12 OF THIS TABLE
- EAST HIGHLAND CANAL AND NORTH FORK CANAL DIVERT WATER TO AGRICULTURAL USE MUNICIPAL USE AND LIMITED SPREADING. DATA FROM EAST VALLEY WATER DISTRICT.
- THE CORPS OF ENGINEERS AND SOUTHERN CALIFORNIA EDISON COMPANY DIVERT WATER FROM REDLANDS TUNNEL UPSTREAM OF THE TUNNELS CONFLUENCE WITH REDLANDS CANAL WHICH IS UPSTREAM OF THE REDLANDS CANAL WEIR. STARTING WITH 2008, COUNTY FILING ANNUAL EXTRACTION AMOUNTS; RECORDATION #3603900
- DATA FROM SAN BERNARDINO VALLEY MUNICIPAL WATER DISTRICT RECORDS OF OPERATIONS OF REDLANDS CANAL WEIR AND REDLANDS CANAL.
- DATA FROM SAN BERNARDINO VALLEY MUNICIPAL WATER DISTRICT RECORDS OF OPERATIONS OF BEAR VALLEY HIGHLINE SAN BERNARDINO VALLEY MUNICIPAL WATER DISTRICT COMPLETED ITS GREENSPOT HIGHLINE PIPELINE IN 1985.
- SANTA ANA NO.1 AND NO. 2 WELLS ARE LOCATED IN UPPER SANTA ANA CANYON AND PUMPED DIRECTLY TO POWER CANALS. DIVERSION OF STREAFLOW AND WELL EXTRACTIIONS ARE COMMINGLED. DATA FROM SAN BERNARDINO VALLEY WATER CONSERVATION DISTRICT.

TABLE NO. 6

SANTA ANA RIVER
VERIFICATIONS OF EXTRACTIONS
FOR CALENDAR YEAR 2012

LINE NO.	LOCATION OF MEASUREMENT	JAN	FEB	MAR	APR	MAY	JUN	JUL	AUG	SEP	OCT	NOV	DEC	TOTAL	REMARKS
1	SANTA ANA RIVER NEAR MENTONE STREAMFLOW [11051500]	236	277	944	4,005	716	766	780	935	1,016	365	141	159	10,340	SEE NOTE 1
2	SANTA ANA RIVER NEAR MENTONE POWER CANALS [Ln 3 - Ln 1]	1,871	1,778	1,858	2,372	1,660	866	415	412	390	893	836	1,304	14,655	SEE NOTE 1
3	SANTA ANA RIVER NEAR MENTONE COMBINED FLOW [11051501]	2,107	2,055	2,802	6,377	2,376	1,632	1,195	1,347	1,406	1,258	977	1,463	24,995	SEE NOTE 1
4	REDLANDS WATER COMPANY REDLANDS TUNNEL [SBVWCD data]	29	29	40	66	64	47	42	47	48	42	23	52	529	SEE NOTE 2
5	TOTAL FLOW AVAILABLE FOR DIVERSION	2,136	2,084	2,842	6,443	2,440	1,679	1,237	1,394	1,454	1,300	1,000	1,515	25,524	LINE 3+4
DIVERSIONS															
6	EAST HIGHLAND CANAL	50	30	18	27	36	43	36	32	47	43	31	25	418	SEE NOTE 3
7	LESS SPREADING [from EVWID]							Not in Service							SEE NOTE 3
8	NET EAST HIGHLAND CANAL DIVERSIONS	50	30	18	27	36	43	36	32	47	43	31	25	418	LINE 6-7
NORTH FORK DIVERSION															
9	NORTH FORK WEIR [SBVWCD data]	248	136	242	393	435	393	440	386	105	186	274	175	3,413	SEE NOTE 3
10	LESS SPREADING FROM CANAL AT CITY CR. & SAND CYN. [from EVWID]	0	4	44	0	0	0	2	2	0	0	26	7	85	SEE NOTE 3
11	NET NORTH FORK DIVERSION	248	132	198	393	435	393	438	384	105	186	248	168	3,328	LINE 9-10
REDLANDS CANAL															
12	CORPS OF ENGINEERS & SO. CAL. EDISON CO. USE Reported as 3603900	0	0	0	0	0	0	0	0	0	0	0	0	0	SEE NOTE 4
13	SBVWCD DIVERSIONS AT MORTON CANYON CONNECTION	1,283	1,304	1,062	1,301	854	625	204	128	193	401	402	506	8,263	SEE NOTE 5
14	REDLANDS CANAL WEIR AT SANDBOX [SBVWCD Weir records #2, Redlands Aqueduct Weir]	186	294	224	372	542	21	4	0	0	0	171	264	2,078	SEE NOTE 5
15	LESS SPREADING MENTONE RES., JUDSON ST., & AIRPORT [Bear Valley records]	1,097	1,010	838	929	312	604	200	128	193	401	231	242	6,185	LINE 12+12A +13-14
16	NET REDLANDS CANAL DIVERSION	271	259	202	213	369	357	369	274	254	364	266	190	3,388	SEE NOTE 6
17	BEAR VALLEY HIGHLINE	0	0	0	0	0	0	0	0	0	0	0	0	0	SEE NOTE 6
18	LESS SPREADING AT MILL CREEK	0	0	0	0	0	0	0	0	0	0	0	0	0	SEE NOTE 6
19	NET BEAR VALLEY HIGHLINE DIVERSION	271	259	202	213	369	357	369	274	254	364	266	190	3,388	LINE 16-17
SAN BERNARDINO VALLEY MWD GREENSPOT PIPELINE															
20	GREENSPOT METER STATION [SBVWCD Bear Valley High Line inlet meter]	0	0	0	0	0	0	0	0	0	0	0	0	0	SEE NOTE 6
21	LESS SPREADING AT MILL CREEK [SBVWCD delivery line 42]	0	0	0	0	0	0	0	0	0	0	0	0	0	SEE NOTE 6
22	NET GREENSPOT PIPELINE	0	0	0	0	0	0	0	0	0	0	0	0	0	LINE 19-20
23	TOTAL NET DIVERSION FROM AVAILABLE FLOW	1,666	1,431	1,256	1,562	1,152	1,397	1,043	818	599	994	776	625	13,319	LINE 8+11 +15+18+21
DEDUCT SANTA ANA WELLS															
24	SANTA ANA WELL NO. 1 RECORDATION NO. 3600021 [SBVWCD data]	0	0	0	0	0	0	0	0	0	0	0	0	0	SEE NOTE 7
25	SANTA ANA WELL NO. 2 RECORDATION NO. 3600022	0	0	0	0	0	0	0	0	0	0	0	0	0	SEE NOTE 7
26	TOTAL PUMPED WATER	0	0	0	0	0	0	0	0	0	0	0	0	0	LINE 23+24
27	TOTAL SANTA ANA RIVER STREAM DIVERSION AS VERIFIED	1,666	1,431	1,256	1,562	1,152	1,397	1,043	818	599	994	776	625	13,319	LINE 22-25

NOTES

- U.S.G.S. RECORDS OF SANTA ANA RIVER FLOWS
- REDLANDS WATER COMPANY TUNNEL IS AN INFILTRATION GALLERY WHICH INTERCEPTS SANTA ANA RIVER UNDERFLOW. DATA FROM SAN BERNARDINO VALLEY WATER CONSERVATION DISTRICT. FLOW SHOWN INCLUDES LINE NO. 12 OF THIS TABLE
- EAST HIGHLAND CANAL AND NORTH FORK CANAL DIVERT WATER TO AGRICULTURAL USE MUNICIPAL USE AND LIMITED SPREADING. DATA FROM EAST VALLEY WATER DISTRICT.
- THE CORPS OF ENGINEERS AND SOUTHERN CALIFORNIA EDISON COMPANY DIVERT WATER FROM REDLANDS TUNNEL UPSTREAM OF THE TUNNELS CONFLUENCE WITH REDLANDS CANAL WHICH IS UPSTREAM OF THE REDLANDS CANAL WEIR. STARTING WITH 2008. COUNTY FILING ANNUAL EXTRACTION AMOUNTS. RECORDATION #3603900
- DATA FROM SAN BERNARDINO VALLEY MUNICIPAL WATER DISTRICT RECORDS OF OPERATIONS OF REDLANDS CANAL WEIR AND REDLANDS CANAL.
- DATA FROM SAN BERNARDINO VALLEY MUNICIPAL WATER DISTRICT RECORDS OF OPERATIONS OF BEAR VALLEY HIGHLINE. SAN BERNARDINO VALLEY MUNICIPAL WATER DISTRICT COMPLETED ITS GREENSPOT HIGHLINE PIPELINE IN 1986.
- SANTA ANA NO. 1 AND NO. 2 WELLS ARE LOCATED IN UPPER SANTA ANA CANYON AND PUMPED DIRECTLY TO POWER CANALS. DIVERSION OF STREAFLOW AND WELL EXTRACTIONS ARE COMMINGLED. DATA FROM SAN BERNARDINO VALLEY WATER CONSERVATION DISTRICT.

TABLE NO. 7

SUMMARY OF REPORTED EXTRACTIONS FROM
LYTLE CREEK, MILL CREEK AND
SANTA ANA RIVER

TABLE NO. 7
SUMMARY OF REPORTED EXTRACTIONS FROM
LYTLE CREEK, MILL CREEK AND
SANTA ANA RIVER

	1959	1960	1961	1962	1963	1959-63 AVERAGE	2008	2009	2010	2011	2012	2008-12 AVERAGE
<u>FILED LYTLE CREEK DIVERSIONS</u>												
FONTANA UNION WATER COMPANY RECORDATION NO. 3600591 (Breed Line Infiltration- File Closed)	8,487	5,833	4,321	8,732	6,145	6,704						0
SAN BERNARDINO, CITY OF (FORMERLY MOUNT VERNON WATER COMPANY) RECORDATION NO. 3600320 (Mt. Vernon Diversion)	730	730	730	730	730	730	0	0	0	0	0	0
RIALTO, CITY OF RECORDATION NO. 3601718 (Filter Plant)	624	626	625	587	624	617	1,165	1,123	1,210	1,171	1,311	1,196
SAN BERNARDINO, CITY OF RECORDATION NO. 3600739 (Lytle Creek Diversion)	1,069	994	1,286	1,403	1,279	1,206	0	0	0	0	0	0
WEST VALLEY WATER DISTRICT RECORDATION NO. 3600312 (Lytle Creek Diversion)	4,258	2,709	2,424	4,392	4,097	3,576	3,369	3,189	3,322	3,381	2,954	3,243
TOTAL REPORTED DIVERSIONS	15,168	10,892	9,386	15,844	12,875	12,833	4,534	4,312	4,532	4,552	4,265	4,439
<u>FILED AND NON-FILED MILL CREEK DIVERSIONS</u>												
REDLANDS, CITY OF (1) RECORDATION NO. 3601302 (Mill Creek Cools Hat) NON-FILED 1S2W13B (Deliveries terminated in May 1979)	--	--	--	--	--	--	12,332	7,785	10,076	13,492	10,679	10,873
TOTAL REPORTED DIVERSIONS	--	--	--	--	--	--	12,332	7,785	10,076	13,492	10,679	10,873
<u>FILED AND NON-FILED SANTA ANA RIVER DIVERSIONS</u>												
BEAR VALLEY MUTUAL WATER COMPANY (2) RECORDATION NO. 3600028 (Santa Ana River Main Diversion)	--	--	--	--	--	--	13,519	10,368	17,524	16,862	15,560	14,767
REDLANDS WATER COMPANY (Redlands Tunnel) (3) NON-FILED 1S2W08A (rf #104)	--	--	--	--	--	--	625	654	629	739	529	635
TOTAL REPORTED DIVERSIONS	--	--	--	--	--	--	14,144	11,022	18,153	17,601	16,089	15,402

NOTES

1. PRIOR TO 1974 VERIFICATION, THE VERIFIED NET DIVERSIONS FROM MILL CREEK WERE SHOWN ON TABLES 1 AND 2 FOR FILERS AND NON-FILERS RESPECTIVELY. SEE TABLE 5 1974 TO DATE.
2. PRIOR TO 1974 VERIFICATION, THE VERIFIED NET DIVERSIONS FROM SANTA ANA RIVER WERE SHOWN ON TABLES 1 AND 2 FOR FILERS AND NON-FILERS RESPECTIVELY. SEE TABLE 6 1974 TO DATE.

NOTES

3. PRIOR TO 1974 VERIFICATION, THE VERIFIED PRODUCTION OF REDLANDS WATER COMPANY'S REDLANDS TUNNEL WAS SHOWN IN TABLE 2 SEE TABLE 6 1974 TO DATE.

TABLE NO. 8

SUMMARY OF PRODUCTION FROM SAN BERNARDINO
BASIN AREA AND CORRECTION FOR VERIFIED
DIVERSIONS OF MAJOR STREAMFLOWS

Table NO. 8
SUMMARY OF PRODUCTION FROM
SAN BERNARDINO BASIN AREA AND
CORRECTION FOR VERIFIED DIVERSIONS
OF MAJOR STREAM FLOWS

	1959	1960	1961	1962	1963	1959-63 Average	2008	2009	2010	2011	2012	2008-12 Average
TOTAL PRODUCTION FROM SAN BERNARDINO BASIN AREA EXCLUDING MINOR PRODUCTION (1)	190,215	174,242	181,397	175,104	157,665	175,725	189,187	169,718	160,500	164,886	174,836	171,825
TOTAL RECORDED STREAMFLOW DIVERSIONS												
LYTLE CREEK (2)	15,168	10,892	9,386	15,844	12,875	12,833	4,534	4,312	4,532	4,552	4,265	4,439
MILL CREEK (2)	--	--	--	--	--	--	12,332	7,785	10,076	13,492	10,679	10,873
SANTA ANA RIVER (2)	--	--	--	--	--	--	14,144	11,022	18,153	17,601	16,089	15,402
Sub-Total	15,168	10,892	9,386	15,844	12,875	12,833	31,010	23,119	32,761	35,645	31,033	30,714
BASIN TOTAL PRODUCTION LESS MAJOR STREAM DIVERSIONS	175,047	163,350	172,011	159,260	144,790	162,892	158,177	146,599	127,739	129,241	143,803	141,112
VERIFIED STREAMFLOW DIVERSIONS												
LYTLE CREEK (3)	11,499	6,708	4,428	11,755	7,861	8,450	11,784	9,931	15,572	22,098	9,724	13,822
MILL CREEK (4)	--	--	--	--	--	--	6,755	3,143	6,286	7,424	5,659	5,853
SANTA ANA RIVER (5)	--	--	--	--	--	--	14,820	13,414	14,198	13,992	13,319	13,949
Sub-Total	11,499	6,708	4,428	11,755	7,861	8,450	33,359	26,488	36,056	43,514	28,702	33,624
TOTAL VERIFIED PRODUCTION FROM SAN BERNARDINO BASIN AREA EXCLUDING MINOR PRODUCTION (6)	186,546	170,058	176,439	171,015	152,651	171,342	191,536	173,087	163,795	172,755	172,505	174,736
SWP Water BMMWD IN-LIEU DELIVERIES (7)							4,634	5,990	2,479	789	4,696	3,718
PLAINTIFF WATER PUMPED TO OCWD UNDER SBVMWD ADDITIONAL EXTRACTIONS												
TOTAL NON-PLAINTIFF EXTRACTIONS FROM SAN BERNARDINO BASIN AREA EXCLUDING MINOR PRODUCTION (8)	186,546	170,058	176,439	171,015	152,651	171,342	196,170	179,077	166,274	173,544	177,201	178,453

Notes

1. Total Filed and Non-Filed Production All Facilities 25 Acre-Feet Per Year Or Larger - See Table No. 3.
2. From Table No. 7 Summary of Reported Extractions From Lytle Creek, Mill Creek, and Santa Ana River.
3. From Table No. 4 Lytle Creek Verifications of Extractions.
4. From Table No. 5 Mill Creek Verifications of Extractions.
5. From Table No. 6 Santa Ana River Verifications of Extractions (Includes Redlands Water Company's Redlands Tunnel.
6. Total Verified Production All Facilities 25 Acre-Feet Per Year Or Larger.
7. SBVMWD In-Lieu Deliveries To Bear Valley Mutual Water Company - See Annual Report of Big Bear Watermaster.
8. Total Verified Production From San Bernardino Basin Area Excluding Minor Production +
SWP Water BMMWD In-Lieu Deliveries + Plaintiff Water Pumped To OCWD Under SBVMWD Additional Extractions.
9. Extracted under June 16, 1993 6th Amendment to December 22, 1981 agreements. (High Groundwater Mitigation)
10. Extracted under March 3, 1994 7th Amendment to December 22, 1981 agreements. (High Groundwater Mitigation)
11. Extracted under March 15, 1995 8th Amendment to December 22, 1981 agreements. (High Groundwater Mitigation)
12. Extracted under March 6, 1996 9th Amendment to December 22, 1981 agreements. (High Groundwater Mitigation)
13. Extracted under February 19, 1997 10th Amendment to December 22, 1981 agreements. (High Groundwater Mitigation)
14. Extracted under February 18, 1998 11th Amendment to December 22, 1981 agreements. (High Groundwater Mitigation)
15. Extracted under January 19, 1999 13th Amendment to December 22, 1981 agreements. (High Groundwater Mitigation)
16. Extracted under August 16, 2000 15th Amendment to December 22, 1981 agreements. (High Groundwater Mitigation)
17. Extracted under February 7, 2001 17th Amendment to December 22, 1981 agreements. (High Groundwater Mitigation)
18. Extracted under February 6, 2002 19th Amendment to December 22, 1981 agreements. (High Groundwater Mitigation)

PLATE NO. 1

SCHEMATIC DIAGRAM OF LYTLE CREEK
DIVERSION FACILITIES AND CONDUITS

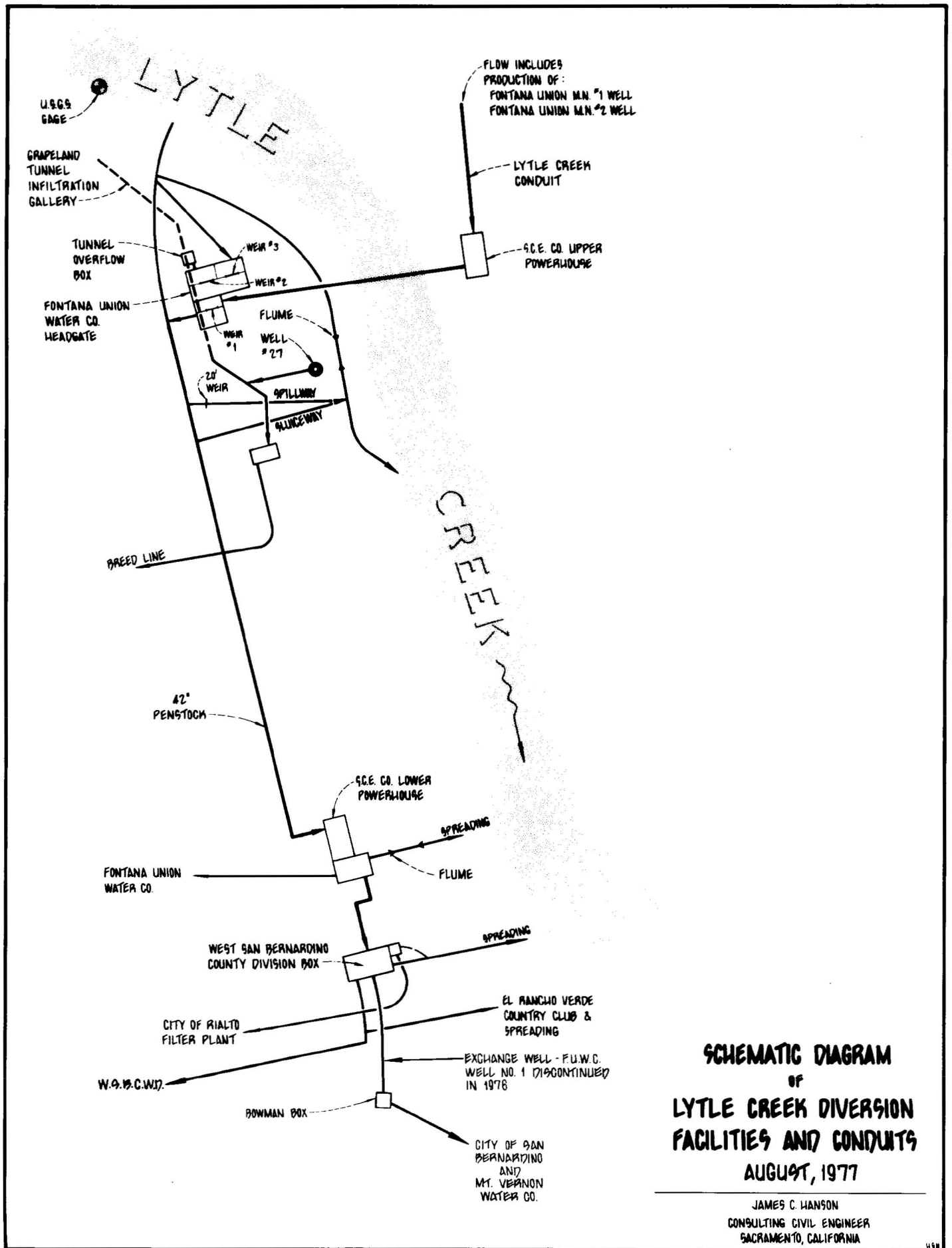
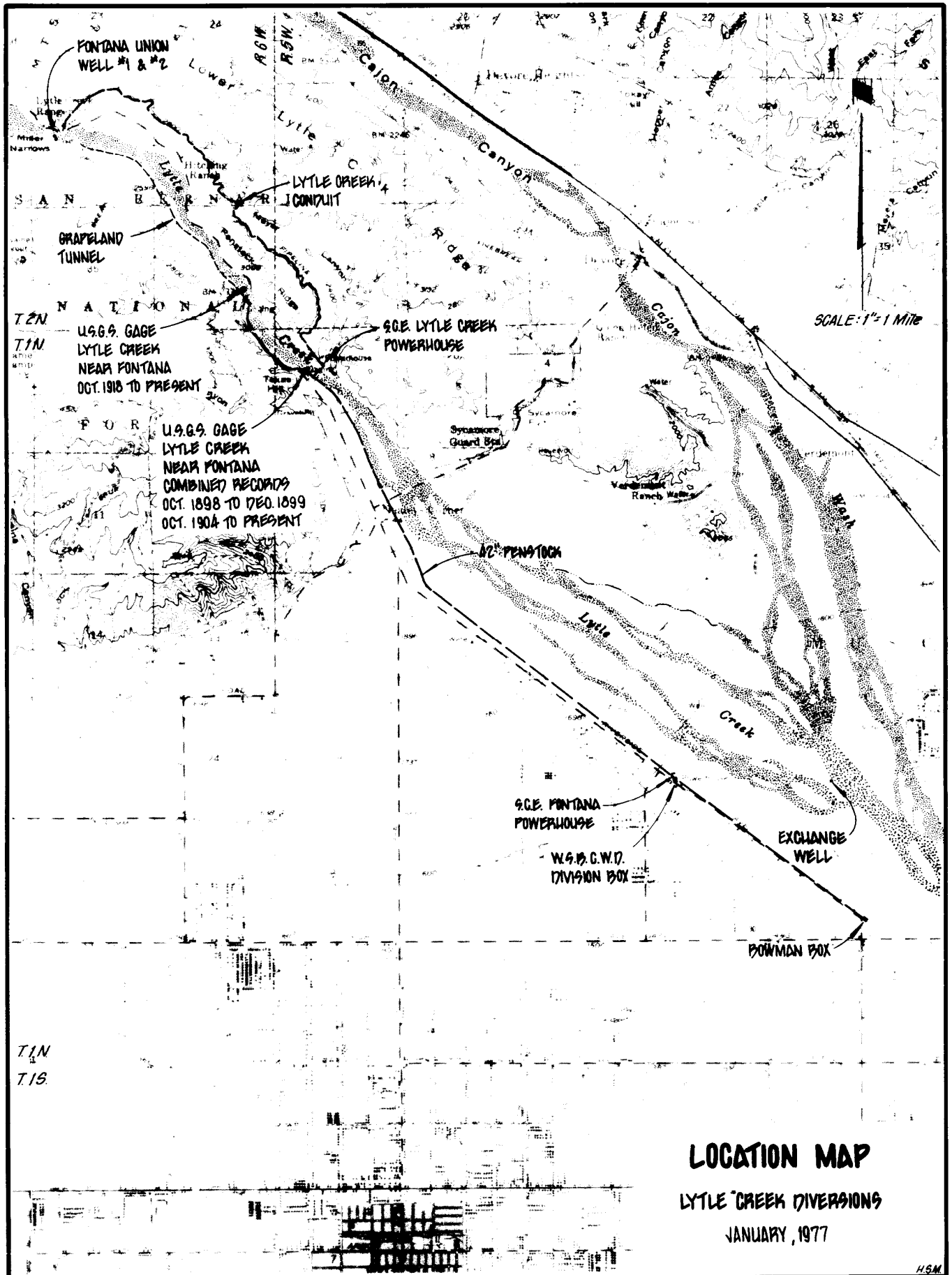


PLATE NO. 1A

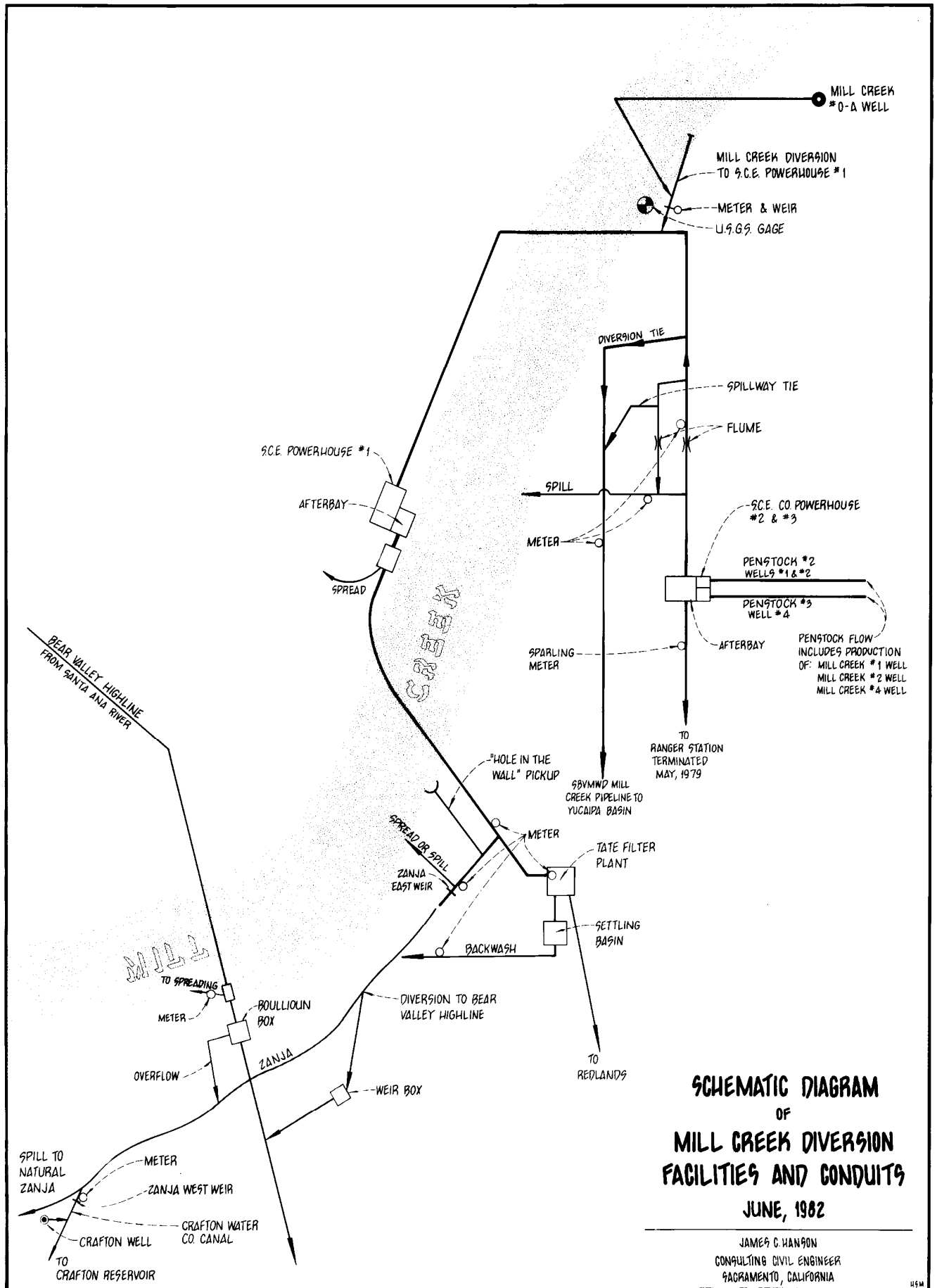
LOCATION MAP, LYTLE CREEK DIVERSIONS



LOCATION MAP
LYTLE CREEK DIVERSIONS
 JANUARY, 1977

PLATE NO. 2

SCHEMATIC DIAGRAM OF MILL CREEK
DIVERSION FACILITIES AND CONDUITS



**SCHEMATIC DIAGRAM
OF
MILL CREEK DIVERSION
FACILITIES AND CONDUITS
JUNE, 1982**

JAMES C. HANSON
CONSULTING CIVIL ENGINEER
SACRAMENTO, CALIFORNIA

PLATE NO. 3

SCHEMATIC DIAGRAM OF SANTA ANA RIVER
DIVERSION FACILITIES AND CONDUITS

PLATE NO. 3A

LOCATION MAP, SANTA ANA RIVER AND
MILL CREEK DIVERSIONS

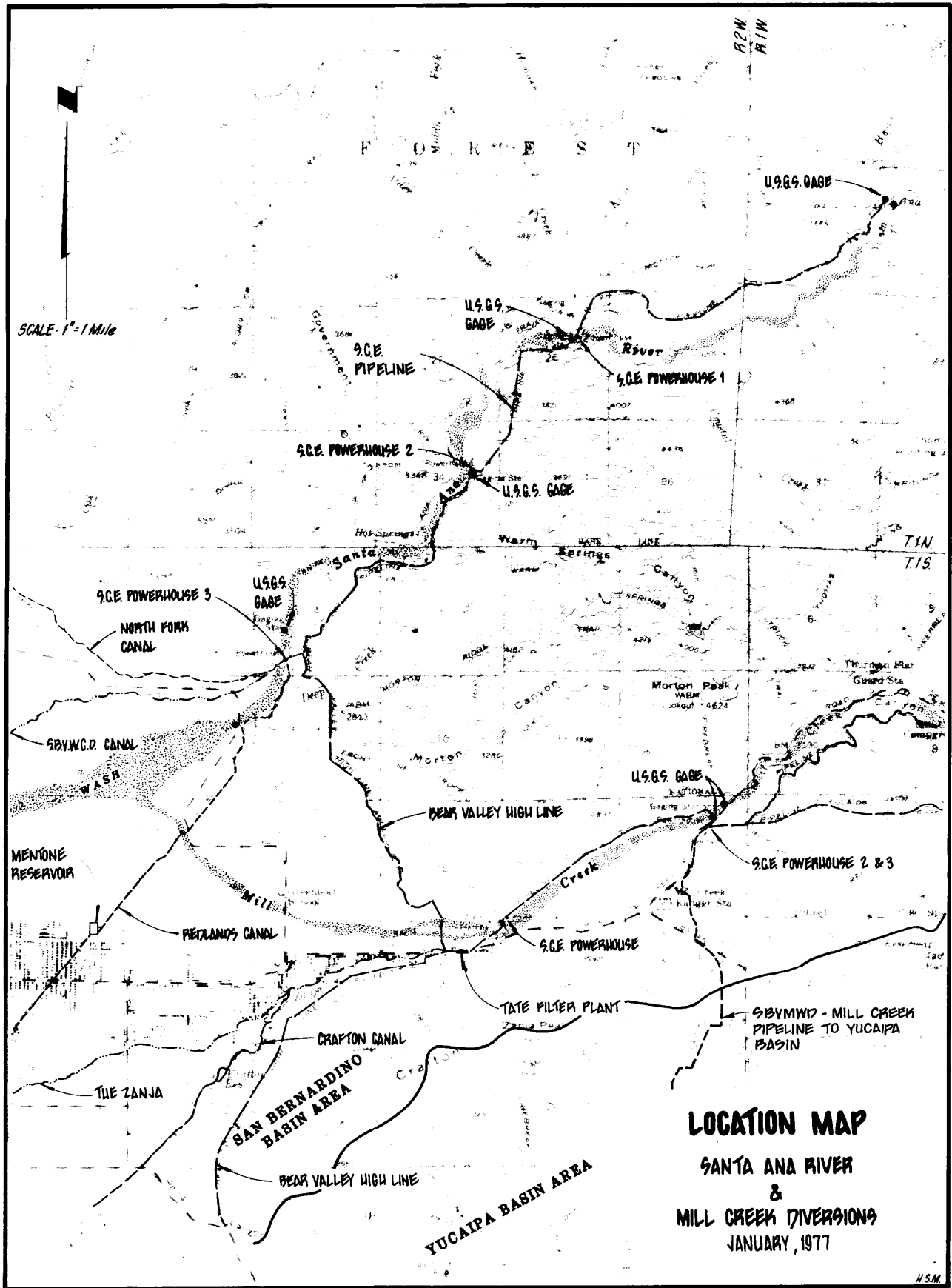
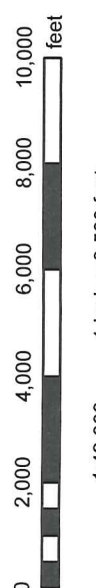
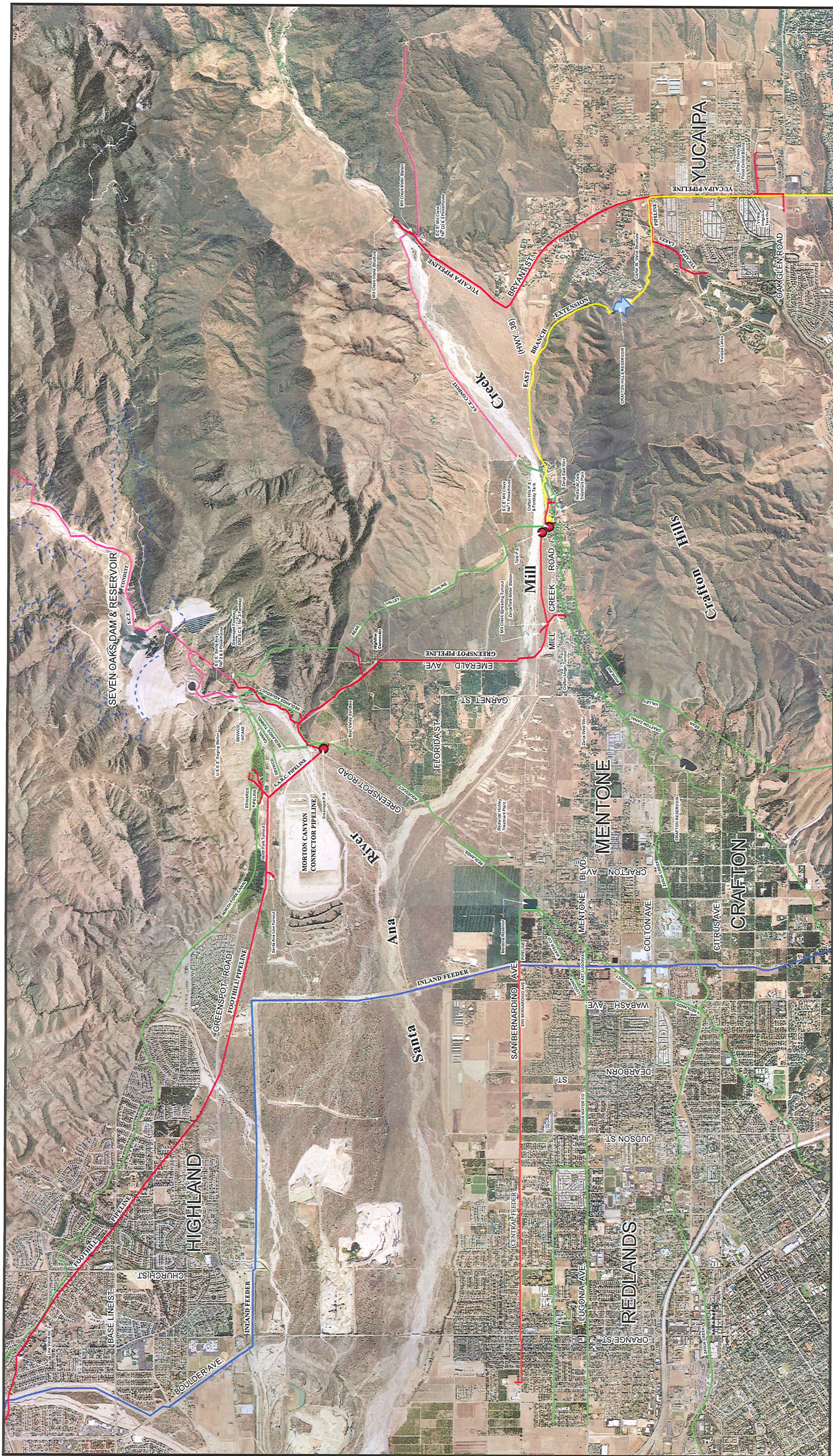


PLATE NO. 4

EAST END FACILITIES MAP



East End Facilities Map

- SBVMWD Facilities
- DWR Facilities
- MWDSC Facilities
- SCE Facilities
- Local Agency Facilities



**WESTERN - SAN BERNARDINO WATERMASTER
FOR
WESTERN MUNICIPAL WATER DISTRICT et al.
vs.
EAST SAN BERNARDINO COUNTY WATER DISTRICT et al.
CASE NO. 78426 - COUNTY OF RIVERSIDE**

VOLUME 1A - 2012

**VERIFIED EXTRACTIONS FROM THE
SAN BERNARDINO BASIN AREA
FOR
CALENDAR YEARS 1959-1963 & 2008-2012**

**By Plaintiffs - City of Riverside, The Gage Canal Co.,
Meeks & Daley Water Co., Agua Mansa Water Co.,
Riverside Highland Water Co.,
and Regents of University of California**

**ANNUAL ACCOUNTING
FOR INDIVIDUAL WELLS**

April 1, 2014

WATERMASTER

*Douglas D. Headrick
John V. Rossi*

REPORT OF WATERMASTER

Western Municipal Water District of Riverside County, et al.
Plaintiffs

vs.

East San Bernardino County Water District, et al.
Defendants

Superior Court of Riverside County

Case No. 78426

VOLUME 1A - 2012

VERIFIED EXTRACTIONS FROM
SAN BERNARDINO BASIN AREA

for

CALENDAR YEARS 1959-1963 AND 2008-2012

By Plaintiffs - City of Riverside, The Gage Canal Company,
Meeks & Daley Water Company, Agua Mansa Water Company,
Riverside Highland Water Company,
and Regents of University of California

ANNUAL ACCOUNTING

FOR INDIVIDUAL WELLS

April 1, 2014

WATERMASTER

Douglas D. Headrick
John V. Rossi

VOLUME 1A - 2012

TABLE OF CONTENTS

<u>CHAPTER I</u>	<u>PAGE</u>
PLAINTIFFS EXTRACTIONS FROM THE SAN BERNARDINO BASIN AREA FOR CALENDAR YEARS 1959-1963 AND 2008-2012	i
 <u>CHAPTER II</u>	
PLAINTIFFS EXTRACTIONS FROM THE SAN BERNARDINO BASIN AREA FOR CALENDAR YEARS 1959-1963 AND 2008-2012 AND DISTRIBUTION BY SERVICE AREA	iii
 MAP - SAN BERNARDINO BASIN AREA - PLAINTIFFS	 1
GRAPH - VERIFIED WATER PRODUCTION BY PLAINTIFFS IN THE SAN BERNARDINO BASIN AREA FOR CALENDAR YEARS 1959-63 and 1971 THROUGH PRESENT	 2
SAN BERNARDINO BASIN AREA, CROSS INDEX BY OWNER - PLAINTIFFS	 3
SAN BERNARDINO BASIN AREA, CROSS INDEX BY STATE WELL NUMBER - PLAINTIFFS	 8
SAN BERNARDINO BASIN AREA, CROSS INDEX BY RECORDATION NUMBER - PLAINTIFFS	 13
 <u>TABLE NO. 1</u>	
VERIFIED EXTRACTIONS BY OWNERS (PLAINTIFFS) WHICH HAVE FILINGS WITH THE WATERMASTER FOR SAN BERNARDINO BASIN AREA	 18
 <u>TABLE NO. 2</u>	
SUMMARY OF EXTRACTIONS (FILED AND NON-FILED BY ALL PLAINTIFFS) FOR SAN BERNARDINO BASIN AREA	 24

TABLE NO. 3

EXTRACTIONS BY PLAINTIFFS FROM THE SAN BERNARDINO
BASIN AREA FOR AVERAGE OF FIVE-YEAR PERIOD ENDING
WITH 1963 AND CALENDAR YEARS 1971 THROUGH CURRENT
YEAR CLASSIFIED ACCORDING TO SERVICE AREA 26

TABLE NO. 4

TOTAL EXTRACTIONS BY PLAINTIFFS FROM
SAN BERNARDINO BASIN AREA 37

TABLE NO. 5

EXTRACTIONS BY PLAINTIFFS FROM THE SAN BERNARDINO BASIN
AREA FOR DELIVERIES IN SAN BERNARDINO BASIN AREA 40

TABLE NO. 6

EXTRACTIONS BY PLAINTIFFS FROM THE SAN BERNARDINO
BASIN AREA FOR DELIVERIES IN COLTON AND RIVERSIDE
BASINS IN SAN BERNARDINO COUNTY 43

TABLE NO. 7

EXTRACTIONS BY PLAINTIFFS FROM THE SAN BERNARDINO
BASIN AREA FOR DELIVERIES OUTSIDE SAN BERNARDINO
VALLEY. 46

VOLUME 1A - 2012

CHAPTER I

PLAINTIFFS EXTRACTIONS FROM THE
SAN BERNARDINO BASIN AREA FOR
CALENDAR YEARS 1959-1963 AND 2008-2012

The provisions of Paragraph IV (B,3) of the Judgment in Case No. 78426 entered April 17, 1969, entitled "San Bernardino Basin Area Rights and Replenishment (Annual Adjusted Rights of Plaintiffs)" provides as follows:

VI(B,3) "In any five-year period, each Plaintiff shall have the right to extract from the San Bernardino Basin area for use in each service area designated in Table B-1 an amount of water equal to five times its adjusted right for such service area; provided, however, that extractions by each Plaintiff in any year in any service area shall not exceed such Plaintiff's adjusted right for that service area by more than 30 percent."

Compliance with this provision of the Judgment requires that an accounting of the total actual extractions of surface and groundwater by the Plaintiffs-City of Riverside, The Gage Canal Co., Meeks & Daley Water Co., Agua Mansa Water Co., Riverside Highland Water Co., and the Regents of the University of California-from the San Bernardino Basin Area be made annually. Included in this Volume 1A-2012 is the verified accounting of such extractions by the Plaintiffs for the Calendar years 2008 through 2012. The extractions for the five-year base period ending with 1963 are also included for comparison.

Three indexes are included which provide a cross index by owner's name, State Water Resources Control Board Well Recordation Number, and State Well Number. Each index shows, in addition, the local designation of each well, if the State has closed the file, which year that occurred, the last 5 years verified extractions and the average for those years.

The individual wells of each owner are listed in Table No. 1, showing the extractions from each well for each year in the five-year base period ending in 1963, the base period average, and the extractions for the years 2008-2012.

Table No. 2 summarizes, by owner, the total annual extractions for the base period and base period average, together with the annual extractions years 2008-2012 and that 5 year period. The total annual extractions for 2012 are 62,294 acre feet.

CHAPTER II

PLAINTIFFS EXTRACTIONS FROM THE SAN BERNARDINO BASIN AREA FOR CALENDAR YEARS 1959-1963 AND 2008-2012 AND DISTRIBUTION BY SERVICE AREA

Paragraph XVI of the Judgment states:

"The provisions of Paragraph 3 and 5 through 12 of this Judgment shall be in effect from and after January 1, 1971; and remaining provisions are in effect immediately."

Thus the annual accounting provisions which relate to extractions from the San Bernardino Basin Area by Plaintiffs were not effective until January 1, 1971.

Table No. 1 and 1A of Chapter I shows the extractions from individual wells owned by each Plaintiff for the five calendar year period ending with 1963, the annual average for said five-year period, and the extractions for the calendar years 2008 through 2012 and the annual average for that period. Table No. 2 described in Chapter I summarizes the total annual extractions for each Plaintiff during the five-year period 1959 through 1963, the annual average for the five-year period, and the 2008 through 2012 extractions and the annual average.

Table No. 3 shows total annual extractions and its distribution.

To facilitate the comparison of the total annual extractions as well as the portions thereof delivered within the San Bernardino Basin Area, the Colton Basin and Riverside Basin within San Bernardino County, and to areas outside San Bernardino Valley, four additional tables have been prepared which summarize the total annual extractions from the San Bernardino Basin Area for the period 1959 through 1963 and 1971 through the current year for each Plaintiff, as well as the portions thereof delivered to various service areas described above.

Table No. 4 lists the Total Extractions from the San Bernardino Basin Area for each Plaintiff annually for the period 1959 through 1963 and the five-year average and calendar years 1971 through the current year.

Similar listings were made for the same period which shows the deliveries within the San Bernardino Basin Area, the deliveries to Colton and Riverside Basins within San Bernardino County, and the deliveries to areas outside San Bernardino Valley. These listings are shown on Tables No. 5, 6, and 7 respectively.

ERRATA

Volume 1A, Bunker Hill Basin
Plaintiffs

During the 2012 Verification, July 2013, the following changes were made to the report.

No changes were made

During the 2011 Verification, July 2012, the following changes were made to the report.

The following 2 wells were **closed** during the year

3601219, Riverside City of, Raub 2, 01S/04W-23C02S, noted abandoned on 2011 filing
3601239, Riverside City of, Raub 3, 01S/04W-14P06S, noted abandoned on 2011 filing

During the 2010 Verification, July 2011, the following corrections were made to the report.

The following 2 new wells were **added** to the files this year

3603950, Meeks & Daley Mutual Water Company, Sperry Well, 01S/04W-21L05S. replaces #36 well which was abandoned.
3603951, Meeks & Daley Water Company, Raub #7 Lease, 01S/04W-23C06S, same as Riverside 3603929.

During the 2009 verification, November 2010, the following corrections were made to the report.

The following 3 new wells were **added** to the files this year

3603931, University of California Riverside, Cooley H Lease, 01S/04W-11D02S,
same well as 3601228 and 3603911
3603939, Meeks & Daley, Garner 6 Lease, 01S/04W-02P09S
same as City of Riverside 3603254
3603940, Meeks & Daley, Garner 7 Lease, 01S/04W-02Q11S
same as City of Riverside 3302794

The following **corrections or additions** were made during the year

3603930, City of Riverside, Raub #7, 01S/04W-23C06S full sw#
received from DWR 02/22/10








The following **back-filings/corrected filing** were made during the year

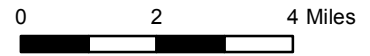
3602423, Riverside - Gage Canal, #6 domestic, corrected
filings from new pump test (with substantial drop in
water level - way off pump curve)
2008 corrected from 16 AF to 3 AF, -13 AF
2007 corrected from 27 AF to 5 AF, -23 AF
2006 corrected from 31 AF to 6 AF, -25 AF

3302794, City of Riverside, Garner 7, 01S/04W-02Q11S was
re-assigned to 3603948. Well was mis-assigned a
Riverside County "33" recordation number in 1996

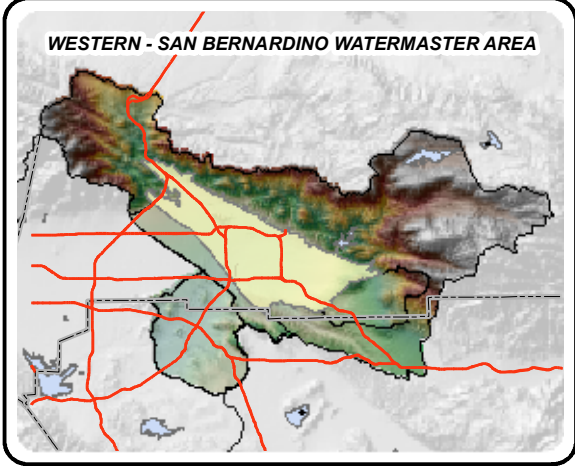
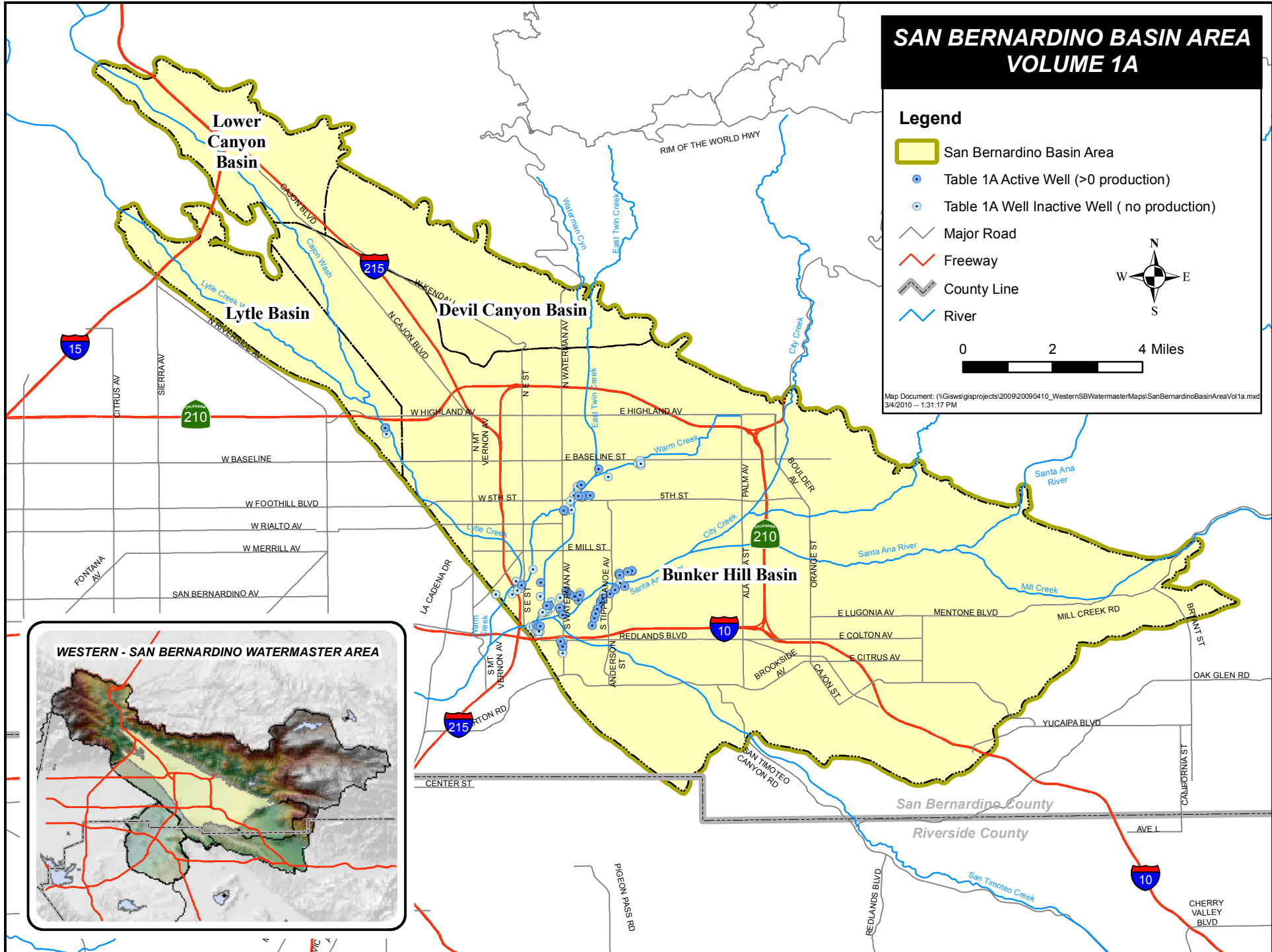
SAN BERNARDINO BASIN AREA VOLUME 1A

Legend

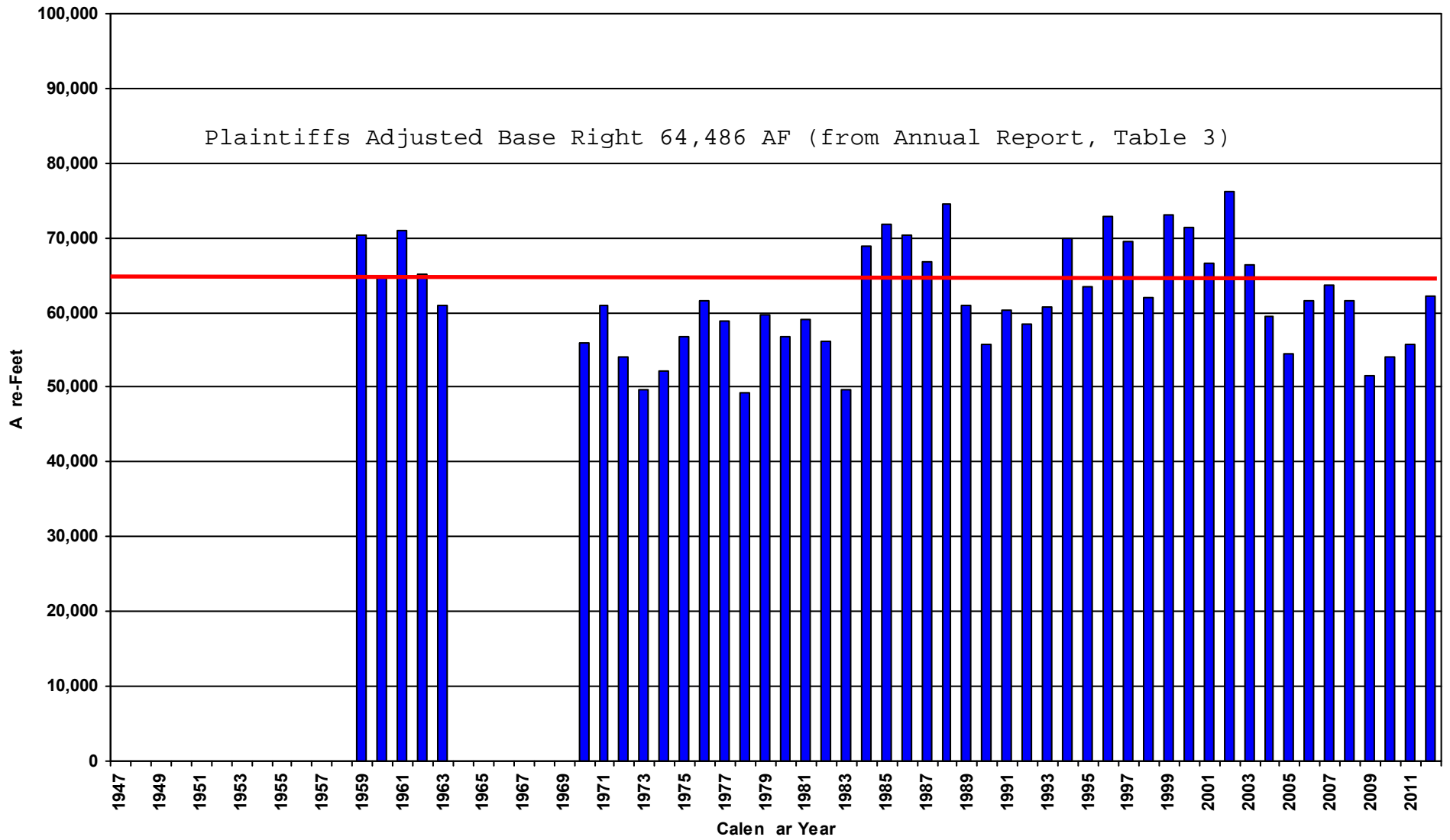
-  San Bernardino Basin Area
-  Table 1A Active Well (>0 production)
-  Table 1A Well Inactive Well (no production)
-  Major Road
-  Freeway
-  County Line
-  River



Map Document: (I:\GIS\sw\gis\projects\2009\20090410_WesternSBWatermasterMaps\SanBernardinoBasinAreaVol1a.mxd
3/4/2010 -- 1:31:17 PM



WESTERN - SAN BERNARDINO WATERMASTER
 Mana in A en Western M ni ipal Water Distri t
SAN BERNARDINO BASIN



SAN BERNARDINO BASIN AREA
CROSS INDEX BY OWNER
PLAINTIFFS

**WESTERN - SAN BERNARDINO WATERMASTER
VERIFIED PRODUCTION DATA
CROSS INDEX BY OWNER
SAN BERNARDINO BASIN**

OWNER	WELL TYPE	RECRDTN NUMBER	STATE NUMBER	WELL LOCAL DESIGNATION	YEAR CLOSED	-----CALENDAR YEAR EXTRACTIONS-----						AVG
						2008	2009	2010	2011	2012		
MEEKS & DALEY WATER COMPANY	W	3601511	01S/04W-15M02S	E STREET	1974	0	0	0	0	0	0	0
MEEKS & DALEY WATER COMPANY	W	3601512	01S/04W-15N05S	51	1967	0	0	0	0	0	0	0
MEEKS & DALEY WATER COMPANY	W	3601513	01S/04W-16R03S	54	1974	0	0	0	0	0	0	0
MEEKS & DALEY WATER COMPANY	D	3601514	01S/04W-16Q	WARM CRK	1974	0	0	0	0	0	0	0
MEEKS & DALEY WATER COMPANY	D	3601515	01S/04W-16Q	WORKMAN	1974	0	0	0	0	0	0	0
MEEKS & DALEY WATER COMPANY	W	3601737	01S/04W-16J09S	COBURN	2005	0	0	0	0	0	0	0
MEEKS & DALEY WATER COMPANY	W	3601887	01S/04W-15L03S	STATION 59		1,374	21	0	3	0	280	
MEEKS & DALEY WATER COMPANY	W	3602169	01S/04W-15M10S	NEW E ST	1991	0	0	0	0	0	0	0
MEEKS & DALEY WATER COMPANY	W	3602329	01S/04W-15E	STATION 66	1974	0	0	0	0	0	0	0
MEEKS & DALEY WATER COMPANY	W	3602863	01S/04W-22H02S	WARREN 4 LEASE		903	0	7	630	857	479	
MEEKS & DALEY WATER COMPANY	W	3602864	01S/04W-14N10S	RAUB #6 LEASE		1,226	1,222	1,298	1,841	2,082	1,534	
MEEKS & DALEY WATER COMPANY	W	3603214	01S/04W-16R04S	STATION 69	2006	0	0	0	0	0	0	0
MEEKS & DALEY WATER COMPANY	W	3603215	01S/04W-15M11S	STATION 91		694	12	0	7	0	143	
MEEKS & DALEY WATER COMPANY	W	3603903	01S/04W-22H04S	WARREN 1 LEASE		635	0	0	0	0	127	
MEEKS & DALEY WATER COMPANY	W	3603905	01S/04W-14N11S	RAUB 8 LEASE		0	1,257	1,870	1,553	366	1,009	
MEEKS & DALEY WATER COMPANY	W	3603906	01S/04W-14N09S	RAUB 5 LEASE		0	841	699	1,154	1,341	807	
MEEKS & DALEY WATER COMPANY	W	3603928	01S/04W-23A07S	TIPPECANOE			0	0	0	0	0	0
MEEKS & DALEY WATER COMPANY	W	3603939	01S/04W-02P09S	GARNER 6 LEASE			1,360	0	0	0	272	
MEEKS & DALEY WATER COMPANY	W	3603940	01S/04W-02Q11S	GARNER 7 LEASE			1,632	0	0	0	326	
MEEKS & DALEY WATER COMPANY	W	3603951	01S/04W-23C06S	RAUB #7 LEASE				2,864	1,939	2,471	1,455	
RIVERSIDE HIGHLAND WATER CO	W	3601522	01S/04W-22M07S	1	1985	0	0	0	0	0	0	0
RIVERSIDE HIGHLAND WATER CO	W	3601523	01S/04W-22L	FW #2		1	0	1	4	1	1	
RIVERSIDE HIGHLAND WATER CO	W	3601527	01S/04W-22P	FW #8	1962	0	0	0	0	0	0	0
RIVERSIDE HIGHLAND WATER CO	W	3601528	01S/04W-22N	FW #10	1962	0	0	0	0	0	0	0
RIVERSIDE HIGHLAND WATER CO	W	3601529	01S/04W-22P	FW #11	1962	0	0	0	0	0	0	0
RIVERSIDE HIGHLAND WATER CO	W	3601530	01S/04W-22L08S	FW #12	2003	0	0	0	0	0	0	0
RIVERSIDE HIGHLAND WATER CO	W	3601533	01S/04W-22L05S	FW #18		0	0	0	0	0	0	0
RIVERSIDE HIGHLAND WATER CO	W	3601535	01N/04W-31D02S	LC #1		0	0	0	0	0	0	0
RIVERSIDE HIGHLAND WATER CO	W	3601536	01N/04W-31E02S	LC #2	1962	0	0	0	0	0	0	0
RIVERSIDE HIGHLAND WATER CO	W	3601537	01S/04W-22N	FLOWING	1963	0	0	0	0	0	0	0
RIVERSIDE HIGHLAND WATER CO	W	3602254	01S/04W-22P05S	FW 24	1985	0	0	0	0	0	0	0
RIVERSIDE HIGHLAND WATER CO	W	3602840	01N/04W-31F01S	LC #8		0	0	0	0	0	0	0
RIVERSIDE HIGHLAND WATER CO	W	3603470	01N/04W-31E03S	LC #10		2,289	1,208	694	1,210	1,694	1,419	
RIVERSIDE HIGHLAND WATER CO	W	3603514	01S/04W-22L17S	FLOW #5		0	0	1	1	0	0	
RIVERSIDE HIGHLAND WATER CO	W	3603907	01S/04W-14N10S	RAUB 6 LEASE		0	0	0	0	0	0	
RIVERSIDE HIGHLAND WATER CO	W	3603908	01S/04W-14N11S	RAUB 8 LEASE		0	0	0	0	0	0	
RIVERSIDE HIGHLAND WATER CO	W	3603911	01S/04W-11D02S	COOLEY H LEASE		90	0	440	440	414	277	

**WESTERN - SAN BERNARDINO WATERMASTER
VERIFIED PRODUCTION DATA
CROSS INDEX BY OWNER
SAN BERNARDINO BASIN**

OWNER	WELL TYPE	RECRDTN NUMBER	STATE NUMBER	WELL LOCAL DESIGNATION	YEAR CLOSED	-----CALENDAR YEAR EXTRACTIONS-----					
						2008	2009	2010	2011	2012	AVG
RIVERSIDE HIGHLAND WATER CO	W	3603912	01S/04W-11D03S	COOLEY I LEASE		350	440	0	0	26	163
RIVERSIDE HIGHLAND WATER CO	W	3603913	01S/04W-11D06S	COOLEY J LEASE		0	0	0	0	0	0
RIVERSIDE, CITY OF	W	3601218	01S/04W-14P02S	RAUB 1	1977	0	0	0	0	0	0
RIVERSIDE, CITY OF	W	3601219	01S/04W-23C02S	RAUB 2	2011	331	0	0	0	0	66
RIVERSIDE, CITY OF	W	3601220	01S/04W-02P04S	COOLEY E	1977	0	0	0	0	0	0
RIVERSIDE, CITY OF	W	3601224	01S/04W-02P03S	COOLEY C	1977	0	0	0	0	0	0
RIVERSIDE, CITY OF	W	3601225	01S/04W-02P02S	COOLEY D	1977	0	0	0	0	0	0
RIVERSIDE, CITY OF	W	3601226	01S/04W-02L02S	COOLEY F	1977	0	0	0	0	0	0
RIVERSIDE, CITY OF	W	3601227	01S/04W-02N02S	COOLEY G	1977	0	0	0	0	0	0
RIVERSIDE, CITY OF	W	3601228	01S/04W-11D02S	COOLEY H		265	45	187	552	51	220
RIVERSIDE, CITY OF	W	3601229	01S/04W-11D03S	COOLEY I		1,449	135	1,279	1,289	1,329	1,096
RIVERSIDE, CITY OF	W	3601230	01S/04W-22H03S	WARREN 3		0	0	0	0	0	0
RIVERSIDE, CITY OF	W	3601231	01S/04W-22H01S	WARREN 2		0	0	0	0	0	0
RIVERSIDE, CITY OF	W	3601232	01S/04W-11D04S	COOLEY A	1977	0	0	0	0	0	0
RIVERSIDE, CITY OF	W	3601233	01S/04W-27A13S	STEWRT 21	1977	0	0	0	0	0	0
RIVERSIDE, CITY OF	W	3601234	01S/04W-27A19S	STEWRT 19	1977	0	0	0	0	0	0
RIVERSIDE, CITY OF	W	3601237	01S/04W-22B02S	BYRNE 1	1977	0	0	0	0	0	0
RIVERSIDE, CITY OF	W	3601238	01S/04W-23C03S	RAUB 4		1,180	1,126	835	1,800	1,294	1,247
RIVERSIDE, CITY OF	W	3601239	01S/04W-14P06S	RAUB 3	2011	680	273	0	0	0	191
RIVERSIDE, CITY OF	W	3601240	01S/04W-22H04S	WARREN 1		0	7	543	32	528	222
RIVERSIDE, CITY OF	W	3601241	01S/04W-27A07S	HUNT 8	1977	0	0	0	0	0	0
RIVERSIDE, CITY OF	W	3601242	01S/04W-27A08S	HUNT 9	1977	0	0	0	0	0	0
RIVERSIDE, CITY OF	W	3601243	01S/04W-22H02S	WARREN 4		0	5	301	64	0	74
RIVERSIDE, CITY OF	W	3601431	01S/04W-27H01S	STEWART 20	1992	0	0	0	0	0	0
RIVERSIDE, CITY OF	W	3601432	01S/04W-11D01S	COOLEY B	1977	0	0	0	0	0	0
RIVERSIDE, CITY OF	W	3601457	01S/04W-01B03S	MCCRARY 1	1977	0	0	0	0	0	0
RIVERSIDE, CITY OF	W	3601458	01S/04W-01B02S	MCCRARY 2	1977	0	0	0	0	0	0
RIVERSIDE, CITY OF	W	3601459	01S/04W-01B	MCCRARY 3	1977	0	0	0	0	0	0
RIVERSIDE, CITY OF	W	3601460	01S/04W-01B	MCCRARY 4	1977	0	0	0	0	0	0
RIVERSIDE, CITY OF	W	3601461	01S/04W-01B	MCCRARY 5	1977	0	0	0	0	0	0
RIVERSIDE, CITY OF	W	3601462	01S/04W-01E01S	POOLE		0	0	0	0	0	0
RIVERSIDE, CITY OF	W	3601463	01S/04W-02A03S	STILES		728	575	231	581	262	475
RIVERSIDE, CITY OF	W	3601464	01S/04W-02P06S	GARNER 1		338	102	52	53	55	120
RIVERSIDE, CITY OF	W	3601465	01S/04W-02Q03S	GARNER 2		0	0	0	0	0	0
RIVERSIDE, CITY OF	W	3601466	01S/04W-02Q07S	GARNER 3	1977	0	0	0	0	0	0
RIVERSIDE, CITY OF	W	3601467	01S/04W-02Q06S	GARNER 4		199	174	104	39	28	109
RIVERSIDE, CITY OF	W	3601468	01S/04W-02P01S	GARNER 5		1,502	1,240	364	1,896	1,864	1,373

**WESTERN - SAN BERNARDINO WATERMASTER
VERIFIED PRODUCTION DATA
CROSS INDEX BY OWNER
SAN BERNARDINO BASIN**

OWNER	WELL TYPE	RECRDTN NUMBER	STATE NUMBER	WELL LOCAL DESIGNATION	YEAR CLOSED	-----CALENDAR YEAR EXTRACTIONS-----					
						2008	2009	2010	2011	2012	AVG
RIVERSIDE, CITY OF	W	3601469	01S/04W-22A01S	PAINEHOT	1977	0	0	0	0	0	0
RIVERSIDE, CITY OF	W	3601470	01S/04W-22G15S	THORN 2	1974	0	0	0	0	0	0
RIVERSIDE, CITY OF	W	3601470-	01S/04W-22B07S	THORN 12		570	38	264	259	435	313
RIVERSIDE, CITY OF	W	3601471	01S/04W-22G14S	THORN 3		0	0	0	0	0	0
RIVERSIDE, CITY OF	W	3601472	01S/04W-22G11S	THORN 4	1977	0	0	0	0	0	0
RIVERSIDE, CITY OF	W	3601473	01S/04W-22G16S	THORN 5		0	0	0	0	0	0
RIVERSIDE, CITY OF	W	3601474	01S/04W-22G18S	THORN 6		0	0	0	0	0	0
RIVERSIDE, CITY OF	W	3601475	01S/04W-22G17S	THORN 7		0	0	0	0	0	0
RIVERSIDE, CITY OF	W	3601476	01S/04W-22G19S	THORN 8		0	0	0	0	0	0
RIVERSIDE, CITY OF	W	3601477	01S/04W-22B01S	THORN 9	1977	0	0	0	0	0	0
RIVERSIDE, CITY OF	W	3601478	01S/04W-22B03S	THORN 10		0	0	1	0	0	0
RIVERSIDE, CITY OF	W	3601479	01S/04W-22B05S	THORN 11		0	0	1	0	0	0
RIVERSIDE, CITY OF	W	3601489	01S/04W-02L01S	SCHEUER	2008	0	0	0	0	0	0
RIVERSIDE, CITY OF	W	3602484	01S/04W-14N09S	RAUB 5		1,933	43	727	3	123	566
RIVERSIDE, CITY OF	W	3602771	01S/04W-27A11S	HUNT 6		0	0	45	7	0	10
RIVERSIDE, CITY OF	W	3602772	01S/04W-27A09S	HUNT 10		0	0	0	0	0	0
RIVERSIDE, CITY OF	W	3602773	01S/04W-27A10S	HUNT 11		0	0	0	0	0	0
RIVERSIDE, CITY OF	W	3602778	01S/04W-14N10S	RAUB 6		956	0	1,191	88	46	456
RIVERSIDE, CITY OF	W	3603254	01S/04W-02P09S	GARNER 6		2,062	271	1,115	2,696	2,472	1,723
RIVERSIDE, CITY OF	W	3603555	01S/04W-14N11S	RAUB 8		1,389	0	50	336	992	553
RIVERSIDE, CITY OF	W	3603775	01S/04W-11D06S	COOLEY J		2,854	1,109	2,025	2,399	1,859	2,049
RIVERSIDE, CITY OF	W	3603923	01S/04W-02L10S	SCHEUER #2		1,799	1,784	1,306	1,473	1,840	1,640
RIVERSIDE, CITY OF	W	3603929	01S/04W-23C06S	RAUB #7			1,227	349	921	260	551
RIVERSIDE, CITY OF	W	3603948	01S/04W-02Q11S	GARNER 7		2,600	357	1,363	2,209	2,946	1,895
RIVERSIDE, CITY OF-GAGE CANAL	W	3600784	01S/04W-13L01S	6	1969	0	0	0	0	0	0
RIVERSIDE, CITY OF-GAGE CANAL	W	3600785	01S/04W-14R	17	1966	0	0	0	0	0	0
RIVERSIDE, CITY OF-GAGE CANAL	W	3600786	01S/04W-13L02S	GAGE 21	1996	0	0	0	0	0	0
RIVERSIDE, CITY OF-GAGE CANAL	W	3600787	01S/04W-23A02S	26-1		1,976	1,422	1,005	3,091	2,785	2,056
RIVERSIDE, CITY OF-GAGE CANAL	W	3600788	01S/04W-23H01S	27-1		2,647	3,658	2,616	13	2,057	2,198
RIVERSIDE, CITY OF-GAGE CANAL	W	3600789	01S/04W-23K01S	27-2		823	1,631	1,787	1,248	713	1,240
RIVERSIDE, CITY OF-GAGE CANAL	W	3600790	01S/04W-23K02S	29-1		1,242	1,444	1,197	746	1,272	1,180
RIVERSIDE, CITY OF-GAGE CANAL	W	3600791	01S/04W-13N01S	29-2		3,491	2,568	3,029	2,041	3,286	2,883
RIVERSIDE, CITY OF-GAGE CANAL	W	3600792	01S/04W-13N02S	29-3		2,167	1,816	1,885	2,417	2,320	2,121
RIVERSIDE, CITY OF-GAGE CANAL	W	3600793	01S/04W-13M02S	30-1		299	100	138	18	0	111
RIVERSIDE, CITY OF-GAGE CANAL	W	3600794	01S/04W-13F02S	31-1		579	666	654	131	0	406
RIVERSIDE, CITY OF-GAGE CANAL	W	3600795	01S/04W-13G02S	46-1	2008	0	0	0	0	0	0
RIVERSIDE, CITY OF-GAGE CANAL	W	3600796	01S/04W-23A05S	51-1		1,408	825	1,355	1,831	2,172	1,518

**WESTERN - SAN BERNARDINO WATERMASTER
 VERIFIED PRODUCTION DATA
 CROSS INDEX BY OWNER
 SAN BERNARDINO BASIN**

OWNER	WELL TYPE	RECRDTN NUMBER	STATE WELL NUMBER	LOCAL DESIGNATION	YEAR CLOSED	-----CALENDAR YEAR EXTRACTIONS-----					
						2008	2009	2010	2011	2012	AVG
RIVERSIDE, CITY OF-GAGE CANAL	W	3600797	01S/04W-13G03S	56-1		768	1,222	902	783	737	882
RIVERSIDE, CITY OF-GAGE CANAL	W	3600798	01S/04W-23G01S	COWLANE	1966	0	0	0	0	0	0
RIVERSIDE, CITY OF-GAGE CANAL	W	3602331	01S/04W-23G03S	66-1		2,872	2,615	2,035	899	2,185	2,121
RIVERSIDE, CITY OF-GAGE CANAL	W	3602423	01S/04W-13P	DOM 6 - HEADGATE		3	7	6	33	15	13
RIVERSIDE, CITY OF-GAGE CANAL	W	3603556	01S/04W-13L08S	92-3		1,511	2,599	2,282	2,604	2,484	2,296
RIVERSIDE, CITY OF-GAGE CANAL	W	3603557	01S/04W-13L07S	92-2		1,606	2,788	2,837	2,639	2,965	2,567
RIVERSIDE, CITY OF-GAGE CANAL	W	3603558	01S/04W-13N07S	92-1		3,376	2,986	2,622	3,524	3,430	3,188
RIVERSIDE, CITY OF-GAGE CANAL	W	3603728	01S/04W-23A06S	98-1		2,510	3,310	3,239	3,387	3,389	3,167
RIVERSIDE, CITY OF-GAGE CANAL	W	3603920	01S/04W-23A07S	TIPPECANOE LEASE		2,767	2,694	4,000	4,228	3,977	3,533
RIVERSIDE, CITY OF-GAGE CANAL	W	3603921	01S/04W-13G04S	46-1R		2,701	2,199	1,791	158	2,335	1,837
UNIVERSITY OF CALIFORNIA, REGENTS OF	W	3601222	01S/04W-27A11S	HUNT 6		74	0	0	0	0	15
UNIVERSITY OF CALIFORNIA, REGENTS OF	W	3601244	01S/04W-27A09S	HUNT 10		92	0	0	0	0	18
UNIVERSITY OF CALIFORNIA, REGENTS OF	W	3601245	01S/04W-27A10S	HUNT 11		76	0	0	0	0	15
UNIVERSITY OF CALIFORNIA, REGENTS OF	W	3603924	01S/04W-22H04S	WARREN #1 LEASE		241	83	55	536	536	290
UNIVERSITY OF CALIFORNIA, REGENTS OF	W	3603925	01S/04W-22H02S	WARREN #4 LEASE		53	88	161	0	0	60
UNIVERSITY OF CALIFORNIA, REGENTS OF	W	3603931	01S/04W-11D02S	COOLEY H LEASE			365	320	0	0	137
UNIVERSITY OF CALIFORNIA, REGENTS OF	W	3691241	01S/04W-27A07S	HUNT 8	1976	0	0	0	0	0	0
UNIVERSITY OF CALIFORNIA, REGENTS OF	W	3691242	01S/04W-27A08S	HUNT 9	1976	0	0	0	0	0	0
TOTALS FOR 129 WELLS						61,679	51,590	54,123	55,806	62,294	57,098

SAN BERNARDINO BASIN AREA
CROSS INDEX BY STATE WELL NUMBER
PLAINTIFFS

**WESTERN - SAN BERNARDINO WATERMASTER
VERIFIED PRODUCTION DATA
CROSS INDEX BY STATE WELL NUMBER
SAN BERNARDINO BASIN**

STATE WELL NUMBER	RECRDTN NUMBER	OWNER	WELL TYPE	LOCAL DESIGNATION	YEAR CLOSED	-----CALENDAR YEAR EXTRACTATIONS-----					
						2008	2009	2010	2011	2012	AVG
01N/04W-31D02S	3601535	RIVERSIDE HIGHLAND WATER CO	W	LC #1		0	0	0	0	0	0
01N/04W-31E02S	3601536	RIVERSIDE HIGHLAND WATER CO	W	LC #2	1962	0	0	0	0	0	0
01N/04W-31E03S	3603470	RIVERSIDE HIGHLAND WATER CO	W	LC #10		2,289	1,208	694	1,210	1,694	1,419
01N/04W-31F01S	3602840	RIVERSIDE HIGHLAND WATER CO	W	LC #8		0	0	0	0	0	0
01S/04W-01B	3601459	RIVERSIDE, CITY OF	W	MCCRARY 3	1977	0	0	0	0	0	0
01S/04W-01B	3601460	RIVERSIDE, CITY OF	W	MCCRARY 4	1977	0	0	0	0	0	0
01S/04W-01B	3601461	RIVERSIDE, CITY OF	W	MCCRARY 5	1977	0	0	0	0	0	0
01S/04W-01B02S	3601458	RIVERSIDE, CITY OF	W	MCCRARY 2	1977	0	0	0	0	0	0
01S/04W-01B03S	3601457	RIVERSIDE, CITY OF	W	MCCRARY 1	1977	0	0	0	0	0	0
01S/04W-01E01S	3601462	RIVERSIDE, CITY OF	W	POOLE		0	0	0	0	0	0
01S/04W-02A03S	3601463	RIVERSIDE, CITY OF	W	STILES		728	575	231	581	262	475
01S/04W-02L01S	3601489	RIVERSIDE, CITY OF	W	SCHEUER	2008	0	0	0	0	0	0
01S/04W-02L02S	3601226	RIVERSIDE, CITY OF	W	COOLEY F	1977	0	0	0	0	0	0
01S/04W-02L10S	3603923	RIVERSIDE, CITY OF	W	SCHEUER #2		1,799	1,784	1,306	1,473	1,840	1,640
01S/04W-02N02S	3601227	RIVERSIDE, CITY OF	W	COOLEY G	1977	0	0	0	0	0	0
01S/04W-02P01S	3601468	RIVERSIDE, CITY OF	W	GARNER 5		1,502	1,240	364	1,896	1,864	1,373
01S/04W-02P02S	3601225	RIVERSIDE, CITY OF	W	COOLEY D	1977	0	0	0	0	0	0
01S/04W-02P03S	3601224	RIVERSIDE, CITY OF	W	COOLEY C	1977	0	0	0	0	0	0
01S/04W-02P04S	3601220	RIVERSIDE, CITY OF	W	COOLEY E	1977	0	0	0	0	0	0
01S/04W-02P06S	3601464	RIVERSIDE, CITY OF	W	GARNER 1		338	102	52	53	55	120
01S/04W-02P09S	3603254	RIVERSIDE, CITY OF	W	GARNER 6		2,062	271	1,115	2,696	2,472	1,723
01S/04W-02P09S	3603939	MEEKS & DALEY WATER COMPANY	W	GARNER 6 LEASE			1,360	0	0	0	272
01S/04W-02Q03S	3601465	RIVERSIDE, CITY OF	W	GARNER 2		0	0	0	0	0	0
01S/04W-02Q06S	3601467	RIVERSIDE, CITY OF	W	GARNER 4		199	174	104	39	28	109
01S/04W-02Q07S	3601466	RIVERSIDE, CITY OF	W	GARNER 3	1977	0	0	0	0	0	0
01S/04W-02Q11S	3603940	MEEKS & DALEY WATER COMPANY	W	GARNER 7 LEASE			1,632	0	0	0	326
01S/04W-02Q11S	3603948	RIVERSIDE, CITY OF	W	GARNER 7		2,600	357	1,363	2,209	2,946	1,895
01S/04W-11D01S	3601432	RIVERSIDE, CITY OF	W	COOLEY B	1977	0	0	0	0	0	0
01S/04W-11D02S	3601228	RIVERSIDE, CITY OF	W	COOLEY H		265	45	187	552	51	220
01S/04W-11D02S	3603911	RIVERSIDE HIGHLAND WATER CO	W	COOLEY H LEASE		90	0	440	440	414	277
01S/04W-11D02S	3603931	UNIVERSITY OF CALIFORNIA, REGENTS OF	W	COOLEY H LEASE			365	320	0	0	137
01S/04W-11D03S	3601229	RIVERSIDE, CITY OF	W	COOLEY I		1,449	135	1,279	1,289	1,329	1,096
01S/04W-11D03S	3603912	RIVERSIDE HIGHLAND WATER CO	W	COOLEY I LEASE		350	440	0	0	26	163
01S/04W-11D04S	3601232	RIVERSIDE, CITY OF	W	COOLEY A	1977	0	0	0	0	0	0
01S/04W-11D06S	3603775	RIVERSIDE, CITY OF	W	COOLEY J		2,854	1,109	2,025	2,399	1,859	2,049
01S/04W-11D06S	3603913	RIVERSIDE HIGHLAND WATER CO	W	COOLEY J LEASE		0	0	0	0	0	0
01S/04W-13F02S	3600794	RIVERSIDE, CITY OF-GAGE CANAL	W	31-1		579	666	654	131	0	406

**WESTERN - SAN BERNARDINO WATERMASTER
VERIFIED PRODUCTION DATA
CROSS INDEX BY STATE WELL NUMBER
SAN BERNARDINO BASIN**

STATE WELL NUMBER	RECRDTN NUMBER	OWNER	WELL TYPE	LOCAL DESIGNATION	YEAR CLOSED	-----CALENDAR YEAR EXTRACTIONS-----					
						2008	2009	2010	2011	2012	AVG
01S/04W-13G02S	3600795	RIVERSIDE, CITY OF-GAGE CANAL	W	46-1	2008	0	0	0	0	0	0
01S/04W-13G03S	3600797	RIVERSIDE, CITY OF-GAGE CANAL	W	56-1		768	1,222	902	783	737	882
01S/04W-13G04S	3603921	RIVERSIDE, CITY OF-GAGE CANAL	W	46-1R		2,701	2,199	1,791	158	2,335	1,837
01S/04W-13L01S	3600784	RIVERSIDE, CITY OF-GAGE CANAL	W	6	1969	0	0	0	0	0	0
01S/04W-13L02S	3600786	RIVERSIDE, CITY OF-GAGE CANAL	W	GAGE 21	1996	0	0	0	0	0	0
01S/04W-13L07S	3603557	RIVERSIDE, CITY OF-GAGE CANAL	W	92-2		1,606	2,788	2,837	2,639	2,965	2,567
01S/04W-13L08S	3603556	RIVERSIDE, CITY OF-GAGE CANAL	W	92-3		1,511	2,599	2,282	2,604	2,484	2,296
01S/04W-13M02S	3600793	RIVERSIDE, CITY OF-GAGE CANAL	W	30-1		299	100	138	18	0	111
01S/04W-13N01S	3600791	RIVERSIDE, CITY OF-GAGE CANAL	W	29-2		3,491	2,568	3,029	2,041	3,286	2,883
01S/04W-13N02S	3600792	RIVERSIDE, CITY OF-GAGE CANAL	W	29-3		2,167	1,816	1,885	2,417	2,320	2,121
01S/04W-13N07S	3603558	RIVERSIDE, CITY OF-GAGE CANAL	W	92-1		3,376	2,986	2,622	3,524	3,430	3,188
01S/04W-13P	3602423	RIVERSIDE, CITY OF-GAGE CANAL	W	DOM 6 - HEADGATE		3	7	6	33	15	13
01S/04W-14N09S	3602484	RIVERSIDE, CITY OF	W	RAUB 5		1,933	43	727	3	123	566
01S/04W-14N09S	3603906	MEEKS & DALEY WATER COMPANY	W	RAUB 5 LEASE		0	841	699	1,154	1,341	807
01S/04W-14N10S	3602778	RIVERSIDE, CITY OF	W	RAUB 6		956	0	1,191	88	46	456
01S/04W-14N10S	3602864	MEEKS & DALEY WATER COMPANY	W	RAUB #6 LEASE		1,226	1,222	1,298	1,841	2,082	1,534
01S/04W-14N10S	3603907	RIVERSIDE HIGHLAND WATER CO	W	RAUB 6 LEASE		0	0	0	0	0	0
01S/04W-14N11S	3603555	RIVERSIDE, CITY OF	W	RAUB 8		1,389	0	50	336	992	553
01S/04W-14N11S	3603905	MEEKS & DALEY WATER COMPANY	W	RAUB 8 LEASE		0	1,257	1,870	1,553	366	1,009
01S/04W-14N11S	3603908	RIVERSIDE HIGHLAND WATER CO	W	RAUB 8 LEASE		0	0	0	0	0	0
01S/04W-14P02S	3601218	RIVERSIDE, CITY OF	W	RAUB 1	1977	0	0	0	0	0	0
01S/04W-14P06S	3601239	RIVERSIDE, CITY OF	W	RAUB 3	2011	680	273	0	0	0	191
01S/04W-14R	3600785	RIVERSIDE, CITY OF-GAGE CANAL	W	17	1966	0	0	0	0	0	0
01S/04W-15E	3602329	MEEKS & DALEY WATER COMPANY	W	STATION 66	1974	0	0	0	0	0	0
01S/04W-15L03S	3601887	MEEKS & DALEY WATER COMPANY	W	STATION 59		1,374	21	0	3	0	280
01S/04W-15M02S	3601511	MEEKS & DALEY WATER COMPANY	W	E STREET	1974	0	0	0	0	0	0
01S/04W-15M10S	3602169	MEEKS & DALEY WATER COMPANY	W	NEW E ST	1991	0	0	0	0	0	0
01S/04W-15M11S	3603215	MEEKS & DALEY WATER COMPANY	W	STATION 91		694	12	0	7	0	143
01S/04W-15N05S	3601512	MEEKS & DALEY WATER COMPANY	W	51	1967	0	0	0	0	0	0
01S/04W-16J09S	3601737	MEEKS & DALEY WATER COMPANY	W	COBURN	2005	0	0	0	0	0	0
01S/04W-16Q	3601514	MEEKS & DALEY WATER COMPANY	D	WARM CRK	1974	0	0	0	0	0	0
01S/04W-16Q	3601515	MEEKS & DALEY WATER COMPANY	D	WORKMAN	1974	0	0	0	0	0	0
01S/04W-16R03S	3601513	MEEKS & DALEY WATER COMPANY	W	54	1974	0	0	0	0	0	0
01S/04W-16R04S	3603214	MEEKS & DALEY WATER COMPANY	W	STATION 69	2006	0	0	0	0	0	0
01S/04W-22A01S	3601469	RIVERSIDE, CITY OF	W	PAINHOT	1977	0	0	0	0	0	0
01S/04W-22B01S	3601477	RIVERSIDE, CITY OF	W	THORN 9	1977	0	0	0	0	0	0
01S/04W-22B02S	3601237	RIVERSIDE, CITY OF	W	BYRNE 1	1977	0	0	0	0	0	0

**WESTERN - SAN BERNARDINO WATERMASTER
VERIFIED PRODUCTION DATA
CROSS INDEX BY STATE WELL NUMBER
SAN BERNARDINO BASIN**

STATE WELL NUMBER	RECRDTN NUMBER	OWNER	WELL TYPE	LOCAL DESIGNATION	YEAR CLOSED	-----CALENDAR YEAR EXTRACTIONS-----					
						2008	2009	2010	2011	2012	AVG
01S/04W-22B03S	3601478	RIVERSIDE, CITY OF	W	THORN 10		0	0	1	0	0	0
01S/04W-22B05S	3601479	RIVERSIDE, CITY OF	W	THORN 11		0	0	1	0	0	0
01S/04W-22B07S	3601470	RIVERSIDE, CITY OF	W	THORN 12		570	38	264	259	435	313
01S/04W-22G11S	3601472	RIVERSIDE, CITY OF	W	THORN 4	1977	0	0	0	0	0	0
01S/04W-22G14S	3601471	RIVERSIDE, CITY OF	W	THORN 3		0	0	0	0	0	0
01S/04W-22G15S	3601470	RIVERSIDE, CITY OF	W	THORN 2	1974	0	0	0	0	0	0
01S/04W-22G16S	3601473	RIVERSIDE, CITY OF	W	THORN 5		0	0	0	0	0	0
01S/04W-22G17S	3601475	RIVERSIDE, CITY OF	W	THORN 7		0	0	0	0	0	0
01S/04W-22G18S	3601474	RIVERSIDE, CITY OF	W	THORN 6		0	0	0	0	0	0
01S/04W-22G19S	3601476	RIVERSIDE, CITY OF	W	THORN 8		0	0	0	0	0	0
01S/04W-22H01S	3601231	RIVERSIDE, CITY OF	W	WARREN 2		0	0	0	0	0	0
01S/04W-22H02S	3601243	RIVERSIDE, CITY OF	W	WARREN 4		0	5	301	64	0	74
01S/04W-22H02S	3602863	MEEKS & DALEY WATER COMPANY	W	WARREN 4 LEASE		903	0	7	630	857	479
01S/04W-22H02S	3603925	UNIVERSITY OF CALIFORNIA, REGENTS OF	W	WARREN #4 LEASE		53	88	161	0	0	60
01S/04W-22H03S	3601230	RIVERSIDE, CITY OF	W	WARREN 3		0	0	0	0	0	0
01S/04W-22H04S	3601240	RIVERSIDE, CITY OF	W	WARREN 1		0	7	543	32	528	222
01S/04W-22H04S	3603903	MEEKS & DALEY WATER COMPANY	W	WARREN 1 LEASE		635	0	0	0	0	127
01S/04W-22H04S	3603924	UNIVERSITY OF CALIFORNIA, REGENTS OF	W	WARREN #1 LEASE		241	83	55	536	536	290
01S/04W-22L	3601523	RIVERSIDE HIGHLAND WATER CO	W	FW #2		1	0	1	4	1	1
01S/04W-22L05S	3601533	RIVERSIDE HIGHLAND WATER CO	W	FW #18		0	0	0	0	0	0
01S/04W-22L08S	3601530	RIVERSIDE HIGHLAND WATER CO	W	FW #12	2003	0	0	0	0	0	0
01S/04W-22L17S	3603514	RIVERSIDE HIGHLAND WATER CO	W	FLOW #5		0	0	1	1	0	0
01S/04W-22M07S	3601522	RIVERSIDE HIGHLAND WATER CO	W	1	1985	0	0	0	0	0	0
01S/04W-22N	3601528	RIVERSIDE HIGHLAND WATER CO	W	FW #10	1962	0	0	0	0	0	0
01S/04W-22N	3601537	RIVERSIDE HIGHLAND WATER CO	W	FLOWING	1963	0	0	0	0	0	0
01S/04W-22P	3601527	RIVERSIDE HIGHLAND WATER CO	W	FW #8	1962	0	0	0	0	0	0
01S/04W-22P	3601529	RIVERSIDE HIGHLAND WATER CO	W	FW #11	1962	0	0	0	0	0	0
01S/04W-22P05S	3602254	RIVERSIDE HIGHLAND WATER CO	W	FW 24	1985	0	0	0	0	0	0
01S/04W-23A02S	3600787	RIVERSIDE, CITY OF-GAGE CANAL	W	26-1		1,976	1,422	1,005	3,091	2,785	2,056
01S/04W-23A05S	3600796	RIVERSIDE, CITY OF-GAGE CANAL	W	51-1		1,408	825	1,355	1,831	2,172	1,518
01S/04W-23A06S	3603728	RIVERSIDE, CITY OF-GAGE CANAL	W	98-1		2,510	3,310	3,239	3,387	3,389	3,167
01S/04W-23A07S	3603920	RIVERSIDE, CITY OF-GAGE CANAL	W	TIPPECANOE LEASE		2,767	2,694	4,000	4,228	3,977	3,533
01S/04W-23A07S	3603928	MEEKS & DALEY WATER COMPANY	W	TIPPECANOE			0	0	0	0	0
01S/04W-23C02S	3601219	RIVERSIDE, CITY OF	W	RAUB 2	2011	331	0	0	0	0	66
01S/04W-23C03S	3601238	RIVERSIDE, CITY OF	W	RAUB 4		1,180	1,126	835	1,800	1,294	1,247
01S/04W-23C06S	3603929	RIVERSIDE, CITY OF	W	RAUB #7			1,227	349	921	260	551
01S/04W-23C06S	3603951	MEEKS & DALEY WATER COMPANY	W	RAUB #7 LEASE				2,864	1,939	2,471	1,455

**WESTERN - SAN BERNARDINO WATERMASTER
 VERIFIED PRODUCTION DATA
 CROSS INDEX BY STATE WELL NUMBER
 SAN BERNARDINO BASIN**

STATE WELL NUMBER	RECRDTN NUMBER	OWNER	WELL TYPE	LOCAL DESIGNATION	YEAR CLOSED	-----CALENDAR YEAR EXTRACTIONS-----					
						2008	2009	2010	2011	2012	AVG
01S/04W-23G01S	3600798	RIVERSIDE, CITY OF-GAGE CANAL	W	COWLANE	1966	0	0	0	0	0	0
01S/04W-23G03S	3602331	RIVERSIDE, CITY OF-GAGE CANAL	W	66-1		2,872	2,615	2,035	899	2,185	2,121
01S/04W-23H01S	3600788	RIVERSIDE, CITY OF-GAGE CANAL	W	27-1		2,647	3,658	2,616	13	2,057	2,198
01S/04W-23K01S	3600789	RIVERSIDE, CITY OF-GAGE CANAL	W	27-2		823	1,631	1,787	1,248	713	1,240
01S/04W-23K02S	3600790	RIVERSIDE, CITY OF-GAGE CANAL	W	29-1		1,242	1,444	1,197	746	1,272	1,180
01S/04W-27A07S	3601241	RIVERSIDE, CITY OF	W	HUNT 8	1977	0	0	0	0	0	0
01S/04W-27A07S	3691241	UNIVERSITY OF CALIFORNIA, REGENTS OF	W	HUNT 8	1976	0	0	0	0	0	0
01S/04W-27A08S	3601242	RIVERSIDE, CITY OF	W	HUNT 9	1977	0	0	0	0	0	0
01S/04W-27A08S	3691242	UNIVERSITY OF CALIFORNIA, REGENTS OF	W	HUNT 9	1976	0	0	0	0	0	0
01S/04W-27A09S	3601244	UNIVERSITY OF CALIFORNIA, REGENTS OF	W	HUNT 10		92	0	0	0	0	18
01S/04W-27A09S	3602772	RIVERSIDE, CITY OF	W	HUNT 10		0	0	0	0	0	0
01S/04W-27A10S	3601245	UNIVERSITY OF CALIFORNIA, REGENTS OF	W	HUNT 11		76	0	0	0	0	15
01S/04W-27A10S	3602773	RIVERSIDE, CITY OF	W	HUNT 11		0	0	0	0	0	0
01S/04W-27A11S	3601222	UNIVERSITY OF CALIFORNIA, REGENTS OF	W	HUNT 6		74	0	0	0	0	15
01S/04W-27A11S	3602771	RIVERSIDE, CITY OF	W	HUNT 6		0	0	45	7	0	10
01S/04W-27A13S	3601233	RIVERSIDE, CITY OF	W	STEWRT 21	1977	0	0	0	0	0	0
01S/04W-27A19S	3601234	RIVERSIDE, CITY OF	W	STEWRT 19	1977	0	0	0	0	0	0
01S/04W-27H01S	3601431	RIVERSIDE, CITY OF	W	STEWART 20	1992	0	0	0	0	0	0
TOTALS FOR 129 WELLS						61,679	51,590	54,123	55,806	62,294	57,098

SAN BERNARDINO BASIN AREA
CROSS INDEX BY RECORDATION NUMBER
PLAINTIFFS

**WESTERN - SAN BERNARDINO WATERMASTER
VERIFIED PRODUCTION DATA
CROSS INDEX BY RECORDATION NUMBER
SAN BERNARDINO BASIN**

RECRDTN NUMBER	STATE WELL NUMBER	WELL OWNER	WELL TYPE	LOCAL DESIGNATION	YEAR CLOSED	-----CALENDAR YEAR EXTRACTIONS-----					
						2008	2009	2010	2011	2012	AVG
3600784	01S/04W-13L01S	RIVERSIDE, CITY OF-GAGE CANAL	W	6	1969	0	0	0	0	0	0
3600785	01S/04W-14R	RIVERSIDE, CITY OF-GAGE CANAL	W	17	1966	0	0	0	0	0	0
3600786	01S/04W-13L02S	RIVERSIDE, CITY OF-GAGE CANAL	W	GAGE 21	1996	0	0	0	0	0	0
3600787	01S/04W-23A02S	RIVERSIDE, CITY OF-GAGE CANAL	W	26-1		1,976	1,422	1,005	3,091	2,785	2,056
3600788	01S/04W-23H01S	RIVERSIDE, CITY OF-GAGE CANAL	W	27-1		2,647	3,658	2,616	13	2,057	2,198
3600789	01S/04W-23K01S	RIVERSIDE, CITY OF-GAGE CANAL	W	27-2		823	1,631	1,787	1,248	713	1,240
3600790	01S/04W-23K02S	RIVERSIDE, CITY OF-GAGE CANAL	W	29-1		1,242	1,444	1,197	746	1,272	1,180
3600791	01S/04W-13N01S	RIVERSIDE, CITY OF-GAGE CANAL	W	29-2		3,491	2,568	3,029	2,041	3,286	2,883
3600792	01S/04W-13N02S	RIVERSIDE, CITY OF-GAGE CANAL	W	29-3		2,167	1,816	1,885	2,417	2,320	2,121
3600793	01S/04W-13M02S	RIVERSIDE, CITY OF-GAGE CANAL	W	30-1		299	100	138	18	0	111
3600794	01S/04W-13F02S	RIVERSIDE, CITY OF-GAGE CANAL	W	31-1		579	666	654	131	0	406
3600795	01S/04W-13G02S	RIVERSIDE, CITY OF-GAGE CANAL	W	46-1	2008	0	0	0	0	0	0
3600796	01S/04W-23A05S	RIVERSIDE, CITY OF-GAGE CANAL	W	51-1		1,408	825	1,355	1,831	2,172	1,518
3600797	01S/04W-13G03S	RIVERSIDE, CITY OF-GAGE CANAL	W	56-1		768	1,222	902	783	737	882
3600798	01S/04W-23G01S	RIVERSIDE, CITY OF-GAGE CANAL	W	COWLANE	1966	0	0	0	0	0	0
3601218	01S/04W-14P02S	RIVERSIDE, CITY OF	W	RAUB 1	1977	0	0	0	0	0	0
3601219	01S/04W-23C02S	RIVERSIDE, CITY OF	W	RAUB 2	2011	331	0	0	0	0	66
3601220	01S/04W-02P04S	RIVERSIDE, CITY OF	W	COOLEY E	1977	0	0	0	0	0	0
3601222	01S/04W-27A11S	UNIVERSITY OF CALIFORNIA, REGENTS OF	W	HUNT 6		74	0	0	0	0	15
3601224	01S/04W-02P03S	RIVERSIDE, CITY OF	W	COOLEY C	1977	0	0	0	0	0	0
3601225	01S/04W-02P02S	RIVERSIDE, CITY OF	W	COOLEY D	1977	0	0	0	0	0	0
3601226	01S/04W-02L02S	RIVERSIDE, CITY OF	W	COOLEY F	1977	0	0	0	0	0	0
3601227	01S/04W-02N02S	RIVERSIDE, CITY OF	W	COOLEY G	1977	0	0	0	0	0	0
3601228	01S/04W-11D02S	RIVERSIDE, CITY OF	W	COOLEY H		265	45	187	552	51	220
3601229	01S/04W-11D03S	RIVERSIDE, CITY OF	W	COOLEY I		1,449	135	1,279	1,289	1,329	1,096
3601230	01S/04W-22H03S	RIVERSIDE, CITY OF	W	WARREN 3		0	0	0	0	0	0
3601231	01S/04W-22H01S	RIVERSIDE, CITY OF	W	WARREN 2		0	0	0	0	0	0
3601232	01S/04W-11D04S	RIVERSIDE, CITY OF	W	COOLEY A	1977	0	0	0	0	0	0
3601233	01S/04W-27A13S	RIVERSIDE, CITY OF	W	STEWRT 21	1977	0	0	0	0	0	0
3601234	01S/04W-27A19S	RIVERSIDE, CITY OF	W	STEWRT 19	1977	0	0	0	0	0	0
3601237	01S/04W-22B02S	RIVERSIDE, CITY OF	W	BYRNE 1	1977	0	0	0	0	0	0
3601238	01S/04W-23C03S	RIVERSIDE, CITY OF	W	RAUB 4		1,180	1,126	835	1,800	1,294	1,247
3601239	01S/04W-14P06S	RIVERSIDE, CITY OF	W	RAUB 3	2011	680	273	0	0	0	191
3601240	01S/04W-22H04S	RIVERSIDE, CITY OF	W	WARREN 1		0	7	543	32	528	222
3601241	01S/04W-27A07S	RIVERSIDE, CITY OF	W	HUNT 8	1977	0	0	0	0	0	0

**WESTERN - SAN BERNARDINO WATERMASTER
VERIFIED PRODUCTION DATA
CROSS INDEX BY RECORDATION NUMBER
SAN BERNARDINO BASIN**

RECRDTN NUMBER	STATE WELL NUMBER	WELL OWNER	WELL TYPE	LOCAL DESIGNATION	YEAR CLOSED	-----CALENDAR YEAR EXTRACTIONS-----					
						2008	2009	2010	2011	2012	AVG
3601242	01S/04W-27A08S	RIVERSIDE, CITY OF	W	HUNT 9	1977	0	0	0	0	0	0
3601243	01S/04W-22H02S	RIVERSIDE, CITY OF	W	WARREN 4		0	5	301	64	0	74
3601244	01S/04W-27A09S	UNIVERSITY OF CALIFORNIA, REGENTS OF	W	HUNT 10		92	0	0	0	0	18
3601245	01S/04W-27A10S	UNIVERSITY OF CALIFORNIA, REGENTS OF	W	HUNT 11		76	0	0	0	0	15
3601431	01S/04W-27H01S	RIVERSIDE, CITY OF	W	STEWART 20	1992	0	0	0	0	0	0
3601432	01S/04W-11D01S	RIVERSIDE, CITY OF	W	COOLEY B	1977	0	0	0	0	0	0
3601457	01S/04W-01B03S	RIVERSIDE, CITY OF	W	MCCRARY 1	1977	0	0	0	0	0	0
3601458	01S/04W-01B02S	RIVERSIDE, CITY OF	W	MCCRARY 2	1977	0	0	0	0	0	0
3601459	01S/04W-01B	RIVERSIDE, CITY OF	W	MCCRARY 3	1977	0	0	0	0	0	0
3601460	01S/04W-01B	RIVERSIDE, CITY OF	W	MCCRARY 4	1977	0	0	0	0	0	0
3601461	01S/04W-01B	RIVERSIDE, CITY OF	W	MCCRARY 5	1977	0	0	0	0	0	0
3601462	01S/04W-01E01S	RIVERSIDE, CITY OF	W	POOLE		0	0	0	0	0	0
3601463	01S/04W-02A03S	RIVERSIDE, CITY OF	W	STILES		728	575	231	581	262	475
3601464	01S/04W-02P06S	RIVERSIDE, CITY OF	W	GARNER 1		338	102	52	53	55	120
3601465	01S/04W-02Q03S	RIVERSIDE, CITY OF	W	GARNER 2		0	0	0	0	0	0
3601466	01S/04W-02Q07S	RIVERSIDE, CITY OF	W	GARNER 3	1977	0	0	0	0	0	0
3601467	01S/04W-02Q06S	RIVERSIDE, CITY OF	W	GARNER 4		199	174	104	39	28	109
3601468	01S/04W-02P01S	RIVERSIDE, CITY OF	W	GARNER 5		1,502	1,240	364	1,896	1,864	1,373
3601469	01S/04W-22A01S	RIVERSIDE, CITY OF	W	PAINEHOT	1977	0	0	0	0	0	0
3601470	01S/04W-22G15S	RIVERSIDE, CITY OF	W	THORN 2	1974	0	0	0	0	0	0
3601470-	01S/04W-22B07S	RIVERSIDE, CITY OF	W	THORN 12		570	38	264	259	435	313
3601471	01S/04W-22G14S	RIVERSIDE, CITY OF	W	THORN 3		0	0	0	0	0	0
3601472	01S/04W-22G11S	RIVERSIDE, CITY OF	W	THORN 4	1977	0	0	0	0	0	0
3601473	01S/04W-22G16S	RIVERSIDE, CITY OF	W	THORN 5		0	0	0	0	0	0
3601474	01S/04W-22G18S	RIVERSIDE, CITY OF	W	THORN 6		0	0	0	0	0	0
3601475	01S/04W-22G17S	RIVERSIDE, CITY OF	W	THORN 7		0	0	0	0	0	0
3601476	01S/04W-22G19S	RIVERSIDE, CITY OF	W	THORN 8		0	0	0	0	0	0
3601477	01S/04W-22B01S	RIVERSIDE, CITY OF	W	THORN 9	1977	0	0	0	0	0	0
3601478	01S/04W-22B03S	RIVERSIDE, CITY OF	W	THORN 10		0	0	1	0	0	0
3601479	01S/04W-22B05S	RIVERSIDE, CITY OF	W	THORN 11		0	0	1	0	0	0
3601489	01S/04W-02L01S	RIVERSIDE, CITY OF	W	SCHEUER	2008	0	0	0	0	0	0
3601511	01S/04W-15M02S	MEEKS & DALEY WATER COMPANY	W	E STREET	1974	0	0	0	0	0	0
3601512	01S/04W-15N05S	MEEKS & DALEY WATER COMPANY	W	51	1967	0	0	0	0	0	0
3601513	01S/04W-16R03S	MEEKS & DALEY WATER COMPANY	W	54	1974	0	0	0	0	0	0
3601514	01S/04W-16Q	MEEKS & DALEY WATER COMPANY	D	WARM CRK	1974	0	0	0	0	0	0

**WESTERN - SAN BERNARDINO WATERMASTER
VERIFIED PRODUCTION DATA
CROSS INDEX BY RECORDATION NUMBER
SAN BERNARDINO BASIN**

RECRDTN NUMBER	STATE WELL NUMBER	OWNER	WELL TYPE	LOCAL DESIGNATION	YEAR CLOSED	-----CALENDAR YEAR EXTRACTIONS-----					
						2008	2009	2010	2011	2012	AVG
3601515	01S/04W-16Q	MEEKS & DALEY WATER COMPANY	D	WORKMAN	1974	0	0	0	0	0	0
3601522	01S/04W-22M07S	RIVERSIDE HIGHLAND WATER CO	W	1	1985	0	0	0	0	0	0
3601523	01S/04W-22L	RIVERSIDE HIGHLAND WATER CO	W	FW #2		1	0	1	4	1	1
3601527	01S/04W-22P	RIVERSIDE HIGHLAND WATER CO	W	FW #8	1962	0	0	0	0	0	0
3601528	01S/04W-22N	RIVERSIDE HIGHLAND WATER CO	W	FW #10	1962	0	0	0	0	0	0
3601529	01S/04W-22P	RIVERSIDE HIGHLAND WATER CO	W	FW #11	1962	0	0	0	0	0	0
3601530	01S/04W-22L08S	RIVERSIDE HIGHLAND WATER CO	W	FW #12	2003	0	0	0	0	0	0
3601533	01S/04W-22L05S	RIVERSIDE HIGHLAND WATER CO	W	FW #18		0	0	0	0	0	0
3601535	01N/04W-31D02S	RIVERSIDE HIGHLAND WATER CO	W	LC #1		0	0	0	0	0	0
3601536	01N/04W-31E02S	RIVERSIDE HIGHLAND WATER CO	W	LC #2	1962	0	0	0	0	0	0
3601537	01S/04W-22N	RIVERSIDE HIGHLAND WATER CO	W	FLOWING	1963	0	0	0	0	0	0
3601737	01S/04W-16J09S	MEEKS & DALEY WATER COMPANY	W	COBURN	2005	0	0	0	0	0	0
3601887	01S/04W-15L03S	MEEKS & DALEY WATER COMPANY	W	STATION 59		1,374	21	0	3	0	280
3602169	01S/04W-15M10S	MEEKS & DALEY WATER COMPANY	W	NEW E ST	1991	0	0	0	0	0	0
3602254	01S/04W-22P05S	RIVERSIDE HIGHLAND WATER CO	W	FW 24	1985	0	0	0	0	0	0
3602329	01S/04W-15E	MEEKS & DALEY WATER COMPANY	W	STATION 66	1974	0	0	0	0	0	0
3602331	01S/04W-23G03S	RIVERSIDE, CITY OF-GAGE CANAL	W	66-1		2,872	2,615	2,035	899	2,185	2,121
3602423	01S/04W-13P	RIVERSIDE, CITY OF-GAGE CANAL	W	DOM 6 - HEADGATE		3	7	6	33	15	13
3602484	01S/04W-14N09S	RIVERSIDE, CITY OF	W	RAUB 5		1,933	43	727	3	123	566
3602771	01S/04W-27A11S	RIVERSIDE, CITY OF	W	HUNT 6		0	0	45	7	0	10
3602772	01S/04W-27A09S	RIVERSIDE, CITY OF	W	HUNT 10		0	0	0	0	0	0
3602773	01S/04W-27A10S	RIVERSIDE, CITY OF	W	HUNT 11		0	0	0	0	0	0
3602778	01S/04W-14N10S	RIVERSIDE, CITY OF	W	RAUB 6		956	0	1,191	88	46	456
3602840	01N/04W-31F01S	RIVERSIDE HIGHLAND WATER CO	W	LC #8		0	0	0	0	0	0
3602863	01S/04W-22H02S	MEEKS & DALEY WATER COMPANY	W	WARREN 4 LEASE		903	0	7	630	857	479
3602864	01S/04W-14N10S	MEEKS & DALEY WATER COMPANY	W	RAUB #6 LEASE		1,226	1,222	1,298	1,841	2,082	1,534
3603214	01S/04W-16R04S	MEEKS & DALEY WATER COMPANY	W	STATION 69	2006	0	0	0	0	0	0
3603215	01S/04W-15M11S	MEEKS & DALEY WATER COMPANY	W	STATION 91		694	12	0	7	0	143
3603254	01S/04W-02P09S	RIVERSIDE, CITY OF	W	GARNER 6		2,062	271	1,115	2,696	2,472	1,723
3603470	01N/04W-31E03S	RIVERSIDE HIGHLAND WATER CO	W	LC #10		2,289	1,208	694	1,210	1,694	1,419
3603514	01S/04W-22L17S	RIVERSIDE HIGHLAND WATER CO	W	FLOW #5		0	0	1	1	0	0
3603555	01S/04W-14N11S	RIVERSIDE, CITY OF	W	RAUB 8		1,389	0	50	336	992	553
3603556	01S/04W-13L08S	RIVERSIDE, CITY OF-GAGE CANAL	W	92-3		1,511	2,599	2,282	2,604	2,484	2,296
3603557	01S/04W-13L07S	RIVERSIDE, CITY OF-GAGE CANAL	W	92-2		1,606	2,788	2,837	2,639	2,965	2,567
3603558	01S/04W-13N07S	RIVERSIDE, CITY OF-GAGE CANAL	W	92-1		3,376	2,986	2,622	3,524	3,430	3,188

**WESTERN - SAN BERNARDINO WATERMASTER
VERIFIED PRODUCTION DATA
CROSS INDEX BY RECORDATION NUMBER
SAN BERNARDINO BASIN**

RECRDTN NUMBER	STATE WELL NUMBER	OWNER	WELL TYPE	LOCAL DESIGNATION	YEAR CLOSED	-----CALENDAR YEAR EXTRACTIONS-----					
						2008	2009	2010	2011	2012	AVG
3603728	01S/04W-23A06S	RIVERSIDE, CITY OF-GAGE CANAL	W	98-1		2,510	3,310	3,239	3,387	3,389	3,167
3603775	01S/04W-11D06S	RIVERSIDE, CITY OF	W	COOLEY J		2,854	1,109	2,025	2,399	1,859	2,049
3603903	01S/04W-22H04S	MEEKS & DALEY WATER COMPANY	W	WARREN 1 LEASE		635	0	0	0	0	127
3603905	01S/04W-14N11S	MEEKS & DALEY WATER COMPANY	W	RAUB 8 LEASE		0	1,257	1,870	1,553	366	1,009
3603906	01S/04W-14N09S	MEEKS & DALEY WATER COMPANY	W	RAUB 5 LEASE		0	841	699	1,154	1,341	807
3603907	01S/04W-14N10S	RIVERSIDE HIGHLAND WATER CO	W	RAUB 6 LEASE		0	0	0	0	0	0
3603908	01S/04W-14N11S	RIVERSIDE HIGHLAND WATER CO	W	RAUB 8 LEASE		0	0	0	0	0	0
3603911	01S/04W-11D02S	RIVERSIDE HIGHLAND WATER CO	W	COOLEY H LEASE		90	0	440	440	414	277
3603912	01S/04W-11D03S	RIVERSIDE HIGHLAND WATER CO	W	COOLEY I LEASE		350	440	0	0	26	163
3603913	01S/04W-11D06S	RIVERSIDE HIGHLAND WATER CO	W	COOLEY J LEASE		0	0	0	0	0	0
3603920	01S/04W-23A07S	RIVERSIDE, CITY OF-GAGE CANAL	W	TIPPECANOE LEASE		2,767	2,694	4,000	4,228	3,977	3,533
3603921	01S/04W-13G04S	RIVERSIDE, CITY OF-GAGE CANAL	W	46-1R		2,701	2,199	1,791	158	2,335	1,837
3603923	01S/04W-02L10S	RIVERSIDE, CITY OF	W	SCHEUER #2		1,799	1,784	1,306	1,473	1,840	1,640
3603924	01S/04W-22H04S	UNIVERSITY OF CALIFORNIA, REGENTS OF	W	WARREN #1 LEASE		241	83	55	536	536	290
3603925	01S/04W-22H02S	UNIVERSITY OF CALIFORNIA, REGENTS OF	W	WARREN #4 LEASE		53	88	161	0	0	60
3603928	01S/04W-23A07S	MEEKS & DALEY WATER COMPANY	W	TIPPECANOE			0	0	0	0	0
3603929	01S/04W-23C06S	RIVERSIDE, CITY OF	W	RAUB #7			1,227	349	921	260	551
3603931	01S/04W-11D02S	UNIVERSITY OF CALIFORNIA, REGENTS OF	W	COOLEY H LEASE			365	320	0	0	137
3603939	01S/04W-02P09S	MEEKS & DALEY WATER COMPANY	W	GARNER 6 LEASE			1,360	0	0	0	272
3603940	01S/04W-02Q11S	MEEKS & DALEY WATER COMPANY	W	GARNER 7 LEASE			1,632	0	0	0	326
3603948	01S/04W-02Q11S	RIVERSIDE, CITY OF	W	GARNER 7		2,600	357	1,363	2,209	2,946	1,895
3603951	01S/04W-23C06S	MEEKS & DALEY WATER COMPANY	W	RAUB #7 LEASE				2,864	1,939	2,471	1,455
3691241	01S/04W-27A07S	UNIVERSITY OF CALIFORNIA, REGENTS OF	W	HUNT 8	1976	0	0	0	0	0	0
3691242	01S/04W-27A08S	UNIVERSITY OF CALIFORNIA, REGENTS OF	W	HUNT 9	1976	0	0	0	0	0	0
TOTALS FOR 129 WELLS						61,679	51,590	54,123	55,806	62,294	57,098

TABLE NO.1

VERIFIED EXTRACTIONS BY OWNERS (PLAINTIFFS) WHICH HAVE FILINGS
WITH THE STATE WATER RESOURCES CONTROL BOARD FOR
THE SAN BERNARDINO BASIN AREA

**WESTERN - SAN BERNARDINO WATERMASTER
TABLE 1
VERIFIED EXTRACTATIONS - FILED
SAN BERNARDINO BASIN**

RECRDTN NUMBER	STATE WELL NUMBER	WELL TYPE	LOCAL DESIGNATION	FC	-----BASE YEARS-----						-----CALENDAR YEAR EXTRACTATIONS-----						
					1959	1960	1961	1962	1963	AVG	2008	2009	2010	2011	2012	AVG	
MEEKS & DALEY WATER COMPANY																	
3603939	01S/04W-02P09S	W	GARNER 6 LEASE	<input type="checkbox"/>							0		1,360	0	0	0	272
3603940	01S/04W-02Q11S	W	GARNER 7 LEASE	<input type="checkbox"/>							0		1,632	0	0	0	326
3603906	01S/04W-14N09S	W	RAUB 5 LEASE	<input type="checkbox"/>							0	0	841	699	1,154	1,341	807
3602864	01S/04W-14N10S	W	RAUB #6 LEASE	<input type="checkbox"/>							0	1,226	1,222	1,298	1,841	2,082	1,534
3603905	01S/04W-14N11S	W	RAUB 8 LEASE	<input type="checkbox"/>							0	0	1,257	1,870	1,553	366	1,009
3602329	01S/04W-15E	W	STATION 66	<input checked="" type="checkbox"/>							0	0	0	0	0	0	0
3601887	01S/04W-15L03S	W	STATION 59	<input type="checkbox"/>	1,276	3,813	4,560	3,350	3,073	3,214	1,374	21	0	3	0	0	280
3601511	01S/04W-15M02S	W	E STREET	<input checked="" type="checkbox"/>	1,711	488	672	1,213	1,126	1,042	0	0	0	0	0	0	0
3602169	01S/04W-15M10S	W	NEW E ST	<input checked="" type="checkbox"/>							0	0	0	0	0	0	0
3603215	01S/04W-15M11S	W	STATION 91	<input type="checkbox"/>							0	694	12	0	7	0	143
3601512	01S/04W-15N05S	W	51	<input checked="" type="checkbox"/>	2,157	2,230	2,201	1,788	2,256	2,126	0	0	0	0	0	0	0
3601737	01S/04W-16J09S	W	COBURN	<input checked="" type="checkbox"/>	600	314	447	299	280	388	0	0	0	0	0	0	0
3601514	01S/04W-16Q	D	WARM CRK	<input checked="" type="checkbox"/>	18	2	0	0	0	4	0	0	0	0	0	0	0
3601515	01S/04W-16Q	D	WORKMAN	<input checked="" type="checkbox"/>	2	0	0	0	0	0	0	0	0	0	0	0	0
3601513	01S/04W-16R03S	W	54	<input checked="" type="checkbox"/>	1,518	1,190	1,519	910	1,119	1,251	0	0	0	0	0	0	0
3603214	01S/04W-16R04S	W	STATION 69	<input checked="" type="checkbox"/>							0	0	0	0	0	0	0
3602863	01S/04W-22H02S	W	WARREN 4 LEASE	<input type="checkbox"/>							0	903	0	7	630	857	479
3603903	01S/04W-22H04S	W	WARREN 1 LEASE	<input type="checkbox"/>							0	635	0	0	0	0	127
3603928	01S/04W-23A07S	W	TIPPECANOE	<input type="checkbox"/>							0	0	0	0	0	0	0
3603951	01S/04W-23C06S	W	RAUB #7 LEASE	<input type="checkbox"/>							0			2,864	1,939	2,471	1,455
TOTALS FOR MEEKS & DALEY WATER COMPANY					7,282	8,037	9,399	7,560	7,854	8,026	4,832	6,345	6,738	7,127	7,117	6,432	
RIVERSIDE HIGHLAND WATER CO																	
3601535	01N/04W-31D02S	W	LC #1	<input type="checkbox"/>	1,397	1,226	1,358	1,141	852	1,195	0	0	0	0	0	0	0
3601536	01N/04W-31E02S	W	LC #2	<input checked="" type="checkbox"/>	0	0	0	0	0	0	0	0	0	0	0	0	0
3603470	01N/04W-31E03S	W	LC #10	<input type="checkbox"/>							0	2,289	1,208	694	1,210	1,694	1,419
3602840	01N/04W-31F01S	W	LC #8	<input type="checkbox"/>							0	0	0	0	0	0	0
3603911	01S/04W-11D02S	W	COOLEY H LEASE	<input type="checkbox"/>							0	90	0	440	440	414	277
3603912	01S/04W-11D03S	W	COOLEY I LEASE	<input type="checkbox"/>							0	350	440	0	0	26	163
3603913	01S/04W-11D06S	W	COOLEY J LEASE	<input type="checkbox"/>							0	0	0	0	0	0	0
3603907	01S/04W-14N10S	W	RAUB 6 LEASE	<input type="checkbox"/>							0	0	0	0	0	0	0

WESTERN - SAN BERNARDINO WATERMASTER
TABLE 1
VERIFIED EXTRACTIIONS - FILED
SAN BERNARDINO BASIN

RECRDTN NUMBER	STATE WELL NUMBER	WELL TYPE	LOCAL DESIGNATION	FC	-----BASE YEARS-----						-----CALENDAR YEAR EXTRACTIIONS-----					
					1959	1960	1961	1962	1963	AVG	2008	2009	2010	2011	2012	AVG
3603908	01S/04W-14N11S	W	RAUB 8 LEASE	<input type="checkbox"/>						0	0	0	0	0	0	0
3601523	01S/04W-22L	W	FW #2	<input type="checkbox"/>	802	576	995	796	634	761	1	0	1	4	1	1
3601533	01S/04W-22L05S	W	FW #18	<input type="checkbox"/>	1,551	1,482	1,749	1,125	1,062	1,394	0	0	0	0	0	0
3601530	01S/04W-22L08S	W	FW #12	<input checked="" type="checkbox"/>	255	200	546	346	379	345	0	0	0	0	0	0
3603514	01S/04W-22L17S	W	FLOW #5	<input type="checkbox"/>						0	0	0	1	1	0	0
3601522	01S/04W-22M07S	W	1	<input checked="" type="checkbox"/>	740	757	887	739	399	704	0	0	0	0	0	0
3601528	01S/04W-22N	W	FW #10	<input checked="" type="checkbox"/>	0	0	0	0	0	0	0	0	0	0	0	0
3601537	01S/04W-22N	W	FLOWING	<input checked="" type="checkbox"/>	0	0	0	0	0	0	0	0	0	0	0	0
3601527	01S/04W-22P	W	FW #8	<input checked="" type="checkbox"/>	0	0	0	0	0	0	0	0	0	0	0	0
3601529	01S/04W-22P	W	FW #11	<input checked="" type="checkbox"/>	0	0	0	0	0	0	0	0	0	0	0	0
3602254	01S/04W-22P05S	W	FW 24	<input checked="" type="checkbox"/>						0	0	0	0	0	0	0
TOTALS FOR RIVERSIDE HIGHLAND WATER CO					4,745	4,241	5,535	4,147	3,326	4,399	2,730	1,648	1,136	1,655	2,135	1,861
RIVERSIDE, CITY OF																
3601459	01S/04W-01B	W	MCCRARY 3	<input checked="" type="checkbox"/>	0	0	0	0	0	0	0	0	0	0	0	0
3601460	01S/04W-01B	W	MCCRARY 4	<input checked="" type="checkbox"/>	0	0	0	0	0	0	0	0	0	0	0	0
3601461	01S/04W-01B	W	MCCRARY 5	<input checked="" type="checkbox"/>	0	0	0	0	0	0	0	0	0	0	0	0
3601458	01S/04W-01B02S	W	MCCRARY 2	<input checked="" type="checkbox"/>	0	0	0	0	0	0	0	0	0	0	0	0
3601457	01S/04W-01B03S	W	MCCRARY 1	<input checked="" type="checkbox"/>	0	0	0	0	0	0	0	0	0	0	0	0
3601462	01S/04W-01E01S	W	POOLE	<input type="checkbox"/>	887	1,043	1,428	1,088	1,004	1,090	0	0	0	0	0	0
3601463	01S/04W-02A03S	W	STILES	<input type="checkbox"/>	1,808	1,070	1,686	1,354	1,220	1,428	728	575	231	581	262	475
3601489	01S/04W-02L01S	W	SCHEUER	<input checked="" type="checkbox"/>	0	410	830	758	789	557	0	0	0	0	0	0
3601226	01S/04W-02L02S	W	COOLEY F	<input checked="" type="checkbox"/>	0	0	0	0	0	0	0	0	0	0	0	0
3603923	01S/04W-02L10S	W	SCHEUER #2	<input type="checkbox"/>						0	1,799	1,784	1,306	1,473	1,840	1,640
3601227	01S/04W-02N02S	W	COOLEY G	<input checked="" type="checkbox"/>	0	0	0	0	0	0	0	0	0	0	0	0
3601468	01S/04W-02P01S	W	GARNER 5	<input type="checkbox"/>	1,822	1,853	1,523	978	912	1,418	1,502	1,240	364	1,896	1,864	1,373
3601225	01S/04W-02P02S	W	COOLEY D	<input checked="" type="checkbox"/>	0	0	0	0	0	0	0	0	0	0	0	0
3601224	01S/04W-02P03S	W	COOLEY C	<input checked="" type="checkbox"/>	0	0	0	0	0	0	0	0	0	0	0	0
3601220	01S/04W-02P04S	W	COOLEY E	<input checked="" type="checkbox"/>	0	0	0	0	0	0	0	0	0	0	0	0
3601464	01S/04W-02P06S	W	GARNER 1	<input type="checkbox"/>	613	1,379	1,190	988	989	1,032	338	102	52	53	55	120
3603254	01S/04W-02P09S	W	GARNER 6	<input type="checkbox"/>						0	2,062	271	1,115	2,696	2,472	1,723
3601465	01S/04W-02Q03S	W	GARNER 2	<input type="checkbox"/>	512	527	884	811	546	656	0	0	0	0	0	0

WESTERN - SAN BERNARDINO WATERMASTER
TABLE 1
VERIFIED EXTRACTIONS - FILED
SAN BERNARDINO BASIN

RECRDTN NUMBER	STATE WELL NUMBER	WELL TYPE	LOCAL DESIGNATION	FC	-----BASE YEARS-----						-----CALENDAR YEAR EXTRACTIONS-----					
					1959	1960	1961	1962	1963	AVG	2008	2009	2010	2011	2012	AVG
3601467	01S/04W-02Q06S	W	GARNER 4	<input type="checkbox"/>	373	595	967	957	986	776	199	174	104	39	28	109
3601466	01S/04W-02Q07S	W	GARNER 3	<input checked="" type="checkbox"/>	0	0	0	0	0	0	0	0	0	0	0	0
3603948	01S/04W-02Q11S	W	GARNER 7	<input type="checkbox"/>						0	2,600	357	1,363	2,209	2,946	1,895
3601432	01S/04W-11D01S	W	COOLEY B	<input checked="" type="checkbox"/>	0	0	0	0	0	0	0	0	0	0	0	0
3601228	01S/04W-11D02S	W	COOLEY H	<input type="checkbox"/>	957	572	224	793	1,110	731	265	45	187	552	51	220
3601229	01S/04W-11D03S	W	COOLEY I	<input type="checkbox"/>	3,062	1,465	1,770	2,307	2,669	2,255	1,449	135	1,279	1,289	1,329	1,096
3601232	01S/04W-11D04S	W	COOLEY A	<input checked="" type="checkbox"/>	0	0	0	0	0	0	0	0	0	0	0	0
3603775	01S/04W-11D06S	W	COOLEY J	<input type="checkbox"/>						0	2,854	1,109	2,025	2,399	1,859	2,049
3602484	01S/04W-14N09S	W	RAUB 5	<input type="checkbox"/>						0	1,933	43	727	3	123	566
3602778	01S/04W-14N10S	W	RAUB 6	<input type="checkbox"/>						0	956	0	1,191	88	46	456
3603555	01S/04W-14N11S	W	RAUB 8	<input type="checkbox"/>						0	1,389	0	50	336	992	553
3601218	01S/04W-14P02S	W	RAUB 1	<input checked="" type="checkbox"/>	0	0	0	0	0	0	0	0	0	0	0	0
3601239	01S/04W-14P06S	W	RAUB 3	<input checked="" type="checkbox"/>	390	444	356	524	318	406	680	273	0	0	0	191
3601469	01S/04W-22A01S	W	PAINEHOT	<input checked="" type="checkbox"/>	0	0	0	0	0	0	0	0	0	0	0	0
3601477	01S/04W-22B01S	W	THORN 9	<input checked="" type="checkbox"/>	543	332	392	398	298	393	0	0	0	0	0	0
3601237	01S/04W-22B02S	W	BYRNE 1	<input checked="" type="checkbox"/>	440	551	330	371	309	400	0	0	0	0	0	0
3601478	01S/04W-22B03S	W	THORN 10	<input type="checkbox"/>	597	367	412	392	322	418	0	0	1	0	0	0
3601479	01S/04W-22B05S	W	THORN 11	<input type="checkbox"/>	487	317	334	355	259	350	0	0	1	0	0	0
3601470-	01S/04W-22B07S	W	THORN 12	<input type="checkbox"/>		476	1,345	1,244	1,471	907	570	38	264	259	435	313
3601472	01S/04W-22G11S	W	THORN 4	<input checked="" type="checkbox"/>	198	98	48	60	0	81	0	0	0	0	0	0
3601471	01S/04W-22G14S	W	THORN 3	<input type="checkbox"/>	1,264	980	1,225	820	545	967	0	0	0	0	0	0
3601470	01S/04W-22G15S	W	THORN 2	<input checked="" type="checkbox"/>	0	0	0	0	0	0	0	0	0	0	0	0
3601473	01S/04W-22G16S	W	THORN 5	<input type="checkbox"/>	691	584	343	443	364	485	0	0	0	0	0	0
3601475	01S/04W-22G17S	W	THORN 7	<input type="checkbox"/>	509	422	316	377	323	389	0	0	0	0	0	0
3601474	01S/04W-22G18S	W	THORN 6	<input type="checkbox"/>	552	392	326	289	348	381	0	0	0	0	0	0
3601476	01S/04W-22G19S	W	THORN 8	<input type="checkbox"/>	443	277	236	481	270	341	0	0	0	0	0	0
3601231	01S/04W-22H01S	W	WARREN 2	<input type="checkbox"/>	709	869	844	568	550	708	0	0	0	0	0	0
3601243	01S/04W-22H02S	W	WARREN 4	<input type="checkbox"/>	3,222	2,840	2,834	2,839	2,444	2,836	0	5	301	64	0	74
3601230	01S/04W-22H03S	W	WARREN 3	<input type="checkbox"/>	346	408	368	323	177	324	0	0	0	0	0	0
3601240	01S/04W-22H04S	W	WARREN 1	<input type="checkbox"/>	2,445	2,170	1,894	1,440	1,651	1,920	0	7	543	32	528	222
3601219	01S/04W-23C02S	W	RAUB 2	<input checked="" type="checkbox"/>	537	484	637	712	682	610	331	0	0	0	0	66
3601238	01S/04W-23C03S	W	RAUB 4	<input type="checkbox"/>	826	557	815	857	591	729	1,180	1,126	835	1,800	1,294	1,247

WESTERN - SAN BERNARDINO WATERMASTER
TABLE 1
VERIFIED EXTRACTIONS - FILED
SAN BERNARDINO BASIN

RECRDTN NUMBER	STATE WELL NUMBER	WELL TYPE	LOCAL DESIGNATION	FC	-----BASE YEARS-----						-----CALENDAR YEAR EXTRACTIONS-----						
					1959	1960	1961	1962	1963	AVG	2008	2009	2010	2011	2012	AVG	
3603929	01S/04W-23C06S	W	RAUB #7	<input type="checkbox"/>							0		1,227	349	921	260	551
3601241	01S/04W-27A07S	W	HUNT 8	<input checked="" type="checkbox"/>	0	0	0	0	0	0	0	0	0	0	0	0	0
3601242	01S/04W-27A08S	W	HUNT 9	<input checked="" type="checkbox"/>	0	0	0	0	0	0	0	0	0	0	0	0	0
3602772	01S/04W-27A09S	W	HUNT 10	<input type="checkbox"/>	1,202	1,086	961	1,294	891	1,087	0	0	0	0	0	0	0
3602773	01S/04W-27A10S	W	HUNT 11	<input type="checkbox"/>	472	217	54	354	200	259	0	0	0	0	0	0	0
3602771	01S/04W-27A11S	W	HUNT 6	<input type="checkbox"/>	70	234	105	212	136	151	0	0	45	7	0	0	10
3601233	01S/04W-27A13S	W	STEWRT 21	<input checked="" type="checkbox"/>	0	0	0	0	0	0	0	0	0	0	0	0	0
3601234	01S/04W-27A19S	W	STEWRT 19	<input checked="" type="checkbox"/>	0	0	0	0	0	0	0	0	0	0	0	0	0
3601431	01S/04W-27H01S	W	STEWART 20	<input checked="" type="checkbox"/>	6	5	5	4	5	5	0	0	0	0	0	0	0
TOTALS FOR RIVERSIDE, CITY OF					25,983	23,024	24,682	24,391	22,379	24,092	20,835	8,511	12,333	16,697	16,384	14,952	
RIVERSIDE, CITY OF-GAGE CANAL																	
3600794	01S/04W-13F02S	W	31-1	<input type="checkbox"/>	3,219	2,141	2,353	2,057	1,372	2,228	579	666	654	131	0	0	406
3600795	01S/04W-13G02S	W	46-1	<input checked="" type="checkbox"/>	3,640	2,828	2,909	2,820	2,765	2,992	0	0	0	0	0	0	0
3600797	01S/04W-13G03S	W	56-1	<input type="checkbox"/>	3,379	3,148	3,243	3,434	3,299	3,301	768	1,222	902	783	737	882	882
3603921	01S/04W-13G04S	W	46-1R	<input type="checkbox"/>						0	2,701	2,199	1,791	158	2,335	1,837	1,837
3600784	01S/04W-13L01S	W	6	<input checked="" type="checkbox"/>	10	44	68	36	12	34	0	0	0	0	0	0	0
3600786	01S/04W-13L02S	W	GAGE 21	<input checked="" type="checkbox"/>	0	0	0	0	0	0	0	0	0	0	0	0	0
3603557	01S/04W-13L07S	W	92-2	<input type="checkbox"/>						0	1,606	2,788	2,837	2,639	2,965	2,567	2,567
3603556	01S/04W-13L08S	W	92-3	<input type="checkbox"/>						0	1,511	2,599	2,282	2,604	2,484	2,296	2,296
3600793	01S/04W-13M02S	W	30-1	<input type="checkbox"/>	1,582	1,768	1,495	2,145	1,719	1,742	299	100	138	18	0	0	111
3600791	01S/04W-13N01S	W	29-2	<input type="checkbox"/>	3,633	3,693	4,680	3,387	3,475	3,774	3,491	2,568	3,029	2,041	3,286	2,883	2,883
3600792	01S/04W-13N02S	W	29-3	<input type="checkbox"/>	3,537	4,709	5,071	4,094	3,750	4,232	2,167	1,816	1,885	2,417	2,320	2,121	2,121
3603558	01S/04W-13N07S	W	92-1	<input type="checkbox"/>						0	3,376	2,986	2,622	3,524	3,430	3,188	3,188
3602423	01S/04W-13P	W	DOM 6 - HEADGATE	<input type="checkbox"/>						0	3	7	6	33	15	13	13
3600785	01S/04W-14R	W	17	<input checked="" type="checkbox"/>	0	0	0	0	0	0	0	0	0	0	0	0	0
3600787	01S/04W-23A02S	W	26-1	<input type="checkbox"/>	2,950	2,805	2,762	2,535	2,773	2,765	1,976	1,422	1,005	3,091	2,785	2,056	2,056
3600796	01S/04W-23A05S	W	51-1	<input type="checkbox"/>	1,314	1,183	946	642	736	964	1,408	825	1,355	1,831	2,172	1,518	1,518
3603728	01S/04W-23A06S	W	98-1	<input type="checkbox"/>						0	2,510	3,310	3,239	3,387	3,389	3,167	3,167
3603920	01S/04W-23A07S	W	TIPPECANOE LEASE	<input type="checkbox"/>						0	2,767	2,694	4,000	4,228	3,977	3,533	3,533
3600798	01S/04W-23G01S	W	COWLANE	<input checked="" type="checkbox"/>	0	0	0	0	0	0	0	0	0	0	0	0	0
3602331	01S/04W-23G03S	W	66-1	<input type="checkbox"/>						0	2,872	2,615	2,035	899	2,185	2,121	2,121

**WESTERN - SAN BERNARDINO WATERMASTER
TABLE 1
VERIFIED EXTRACTIIONS - FILED
SAN BERNARDINO BASIN**

RECRDTN NUMBER	STATE WELL NUMBER	WELL LOCAL TYPE DESIGNATION	FC	-----BASE YEARS-----							-----CALENDAR YEAR EXTRACTIIONS-----					
				1959	1960	1961	1962	1963	AVG	2008	2009	2010	2011	2012	AVG	
3600788	01S/04W-23H01S	W 27-1	<input type="checkbox"/>	2,840	1,566	2,163	2,207	2,465	2,248	2,647	3,658	2,616	13	2,057	2,198	
3600789	01S/04W-23K01S	W 27-2	<input type="checkbox"/>	3,466	2,409	2,076	2,928	2,239	2,624	823	1,631	1,787	1,248	713	1,240	
3600790	01S/04W-23K02S	W 29-1	<input type="checkbox"/>	2,235	2,725	2,904	2,155	2,394	2,483	1,242	1,444	1,197	746	1,272	1,180	
TOTALS FOR RIVERSIDE, CITY OF-GAGE CANAL				31,805	29,019	30,670	28,440	26,999	29,387	32,746	34,550	33,380	29,791	36,122	33,318	
UNIVERSITY OF CALIFORNIA, REGENTS OF																
3603931	01S/04W-11D02S	W COOLEY H LEASE	<input type="checkbox"/>						0		365	320	0	0	137	
3603925	01S/04W-22H02S	W WARREN #4 LEASE	<input type="checkbox"/>						0	53	88	161	0	0	60	
3603924	01S/04W-22H04S	W WARREN #1 LEASE	<input type="checkbox"/>						0	241	83	55	536	536	290	
3691241	01S/04W-27A07S	W HUNT 8	<input checked="" type="checkbox"/>	0	0	0	0	0	0	0	0	0	0	0	0	
3691242	01S/04W-27A08S	W HUNT 9	<input checked="" type="checkbox"/>	0	0	0	0	0	0	0	0	0	0	0	0	
3601244	01S/04W-27A09S	W HUNT 10	<input type="checkbox"/>	385	386	564	392	309	407	92	0	0	0	0	18	
3601245	01S/04W-27A10S	W HUNT 11	<input type="checkbox"/>	151	77	32	107	69	87	76	0	0	0	0	15	
3601222	01S/04W-27A11S	W HUNT 6	<input type="checkbox"/>	22	83	62	65	47	56	74	0	0	0	0	15	
TOTALS FOR UNIVERSITY OF CALIFORNIA, REGENTS OF				558	546	658	564	425	550	536	536	536	536	536	536	
TOTALS FOR 129 WELLS				70,373	64,867	70,944	65,102	60,983	66,454	61,679	51,590	54,123	55,806	62,294	57,098	

TABLE NO. 2
SUMMARY OF VERIFIED EXTRACTIONS (PLAINTIFFS)
(FILED AND NON-FILED) FOR
THE SAN BERNARDINO BASIN AREA

**WESTERN - SAN BERNARDINO WATERMASTER
TABLE 2
VERIFIED EXTRACTION, SUMMARY - FILED AND NON-FILED
SAN BERNARDINO BASIN**

	-----BASE YEARS-----						-----CALENDAR YEAR EXTRACTIONS-----					
	1959	1960	1961	1962	1963	AVG	2008	2009	2010	2011	2012	AVG
MEEKS & DALEY WATER COMPANY	7,282	8,037	9,399	7,560	7,854	8,026	4,832	6,345	6,738	7,127	7,117	6,432
RIVERSIDE HIGHLAND WATER CO	4,745	4,241	5,535	4,147	3,326	4,399	2,730	1,648	1,136	1,655	2,135	1,861
RIVERSIDE, CITY OF	25,983	23,024	24,682	24,391	22,379	24,092	20,835	8,511	12,333	16,697	16,384	14,952
RIVERSIDE, CITY OF-GAGE CANAL	31,805	29,019	30,670	28,440	26,999	29,387	32,746	34,550	33,380	29,791	36,122	33,318
UNIVERSITY OF CALIFORNIA, REGENTS OF	558	546	658	564	425	550	536	536	536	536	536	536
TOTALS FOR ALL WELLS	70,373	64,867	70,944	65,102	60,983	66,454	61,679	51,590	54,123	55,806	62,294	57,098

TABLE NO. 3
EXTRACTIONS BY PLAINTIFFS FROM THE
SAN BERNARDINO BASIN AREA FOR AVERAGE OF
FIVE-YEAR PERIOD ENDING WITH 1963
AND CALENDAR YEARS 1971 THROUGH CURRENT YEAR
CLASSIFIED ACCORDING TO SERVICE AREA

TABLE NO. 3

page 1 of 10

EXTRACTIONS BY PLAINTIFF
FROM THE SAN BERNARDINO BASIN AREA
FOR AVERAGE OF THE FIVE-YEAR PERIOD ENDING WITH 1963
AND CALENDAR YEARS 1971 THROUGH THE CURRENT YEAR

ADJUSTED BASE RIGHT

CLASSIFIED ACCORDING TO SERVICE AREA
 (Quantities in Acre Feet)

EXTRACTIONS FROM SAN BERNARDINO BASIN AREA
 FOR USE WITHIN AND EXPORT THEREFROM

<u>PLAINTIFFS</u>	Total Extract (1)	Deliveries in the S.B.B.A. Basin (2)	Deliveries in the Colton & Riverside North (3)	Deliveries Outside S.B.V.M.W.D. (4)
CITY OF RIVERSIDE City & Riverside Wtr Co.	-	-	-	-
CITY OF RIVERSIDE Gage Canal Co.	-	-	-	-
SUB TOTAL - C of R	52,199	1,427	1,230	49,542
RIVERSIDE HIGHLAND WATER CO	4,294	0	2,449	1,845
MEEKS & DALEY WATER CO. AGUA MANSA WATER CO.	7,833	0	318	7,515
UNIVERSITY OF CALIFORNIA	536	0	0	536
TOTALS	64,862	1,427	3,997	59,438

From Watermaster Annual Report, Table 3

- Column (1) TOTAL EXTRACTIONS
- Column (2) DELIVERIES IN SAN BERNARDINO BASIN AREA
- Column (3) DELIVERIES IN COLTON & RIVERSIDE BASIN IN SAN BERNARDINO COUNTY
- Column (4) DELIVERIES OUTSIDE SAN BERNARDINO VALLEY MUNICIPAL WATER DISTRICT

TABLE NO. 3
EXTRACTIONS BY PLAINTIFF
FROM THE SAN BERNARDINO BASIN AREA
FOR AVERAGE OF THE FIVE-YEAR PERIOD ENDING WITH 1963
AND CALENDAR YEARS 1971 THROUGH THE CURRENT YEAR

CLASSIFIED ACCORDING TO SERVICE AREA
 (Quantities in Acre Feet)

EXTRACTIONS FROM SAN BERNARDINO BASIN AREA FOR USE WITHIN AND EXPORT THEREFROM

	1 9 7 1				1 9 7 2				1 9 7 3				1 9 7 4				1 9 7 5			
	Total Extract	Del. S.B. Basin	Del. Colton & Riv N	Del. Outside SBVMWD	Total Extract	Del. S.B. Basin	Del. Colton & Riv N	Del. Outside SBVMWD	Total Extract	Del. S.B. Basin	Del. Colton & Riv N	Del. Outside SBVMWD	Total Extract	Del. S.B. Basin	Del. Colton & Riv N	Del. Outside SBVMWD	Total Extract	Del. S.B. Basin	Del. Colton & Riv N	Del. Outside SBVMWD
PLAINTIFFS																				
CITY OF RIVERSIDE City & Riverside Wtr Co.	24,939	0	0	24,939	20,474	0	0	20,474	21,493	0	0	21,493	27,420	0	65	27,355	25,248	0	0	25,248
CITY OF RIVERSIDE Gage Canal Co.	28,943	98	669	28,176	25,220	85	547	24,588	21,529	156	512	20,861	15,947	0	485	15,462	22,714	0	498	22,216
SUB TOTAL - C of R	53,882	98	669	53,115	45,694	85	547	45,062	43,022	156	512	42,354	43,367	0	550	42,817	47,962	0	498	47,464
RIVERSIDE HIGHLAND WATER CO	4,012	0	2,385	1,627	4,532	0	2,229	2,303	3,512	0	1,744	1,768	4,088	0	1,979	2,109	4,709	0	1,996	2,713
MEEKS & DALEY WATER CO. AGUA MANSÁ WATER CO.	2,902	0	383	2,519	3,527	0	377	3,150	2,979	0	250	2,729	4,504	0	246	4,258	3,950	0	168	3,782
UNIVERSITY OF CALIFORNIA	219	0	0	219	239	0	0	239	239	0	0	239	267	0	0	267	179	0	0	179
TOTALS	61,015	98	3,437	57,480	53,992	85	3,153	50,754	49,752	156	2,507	47,089	52,226	0	2,775	49,451	56,800	0	2,662	54,138

Total Extract -- TOTAL EXTRACTIONS.
 Del S.B. Basin -- DELIVERIES IN SAN BERNARDINO BASIN AREA.
 Del. Colton & Riv. N. -- DELIVERIES IN COLTON & RIVERSIDE BASIN IN SAN BERNARDINO COUNTY.
 Del. Outside SBVMWD -- DELIVERIES OUTSIDE SAN BERNARDINO VALLEY MUNICIPAL WATER DISTRICT.

See Report of the Watermaster, same as Volume 5, Distribution of Extractions, Table 36-A

TABLE NO. 3

EXTRACTIONS BY PLAINTIFF
FROM THE SAN BERNARDINO BASIN AREA
FOR AVERAGE OF THE FIVE-YEAR PERIOD ENDING WITH 1963
AND CALENDAR YEARS 1971 THROUGH THE CURRENT YEAR

CLASSIFIED ACCORDING TO SERVICE AREA
 (Quantities in Acre Feet)

EXTRACTIONS FROM SAN BERNARDINO BASIN AREA FOR USE WITHIN AND EXPORT THEREFROM

	1976				1977				1978				1979				1980			
	Total Extract	Del. S.B. Basin	Del. Colton & Riv N	Del. Outside SBVMWD	Total Extract	Del. S.B. Basin	Del. Colton & Riv N	Del. Outside SBVMWD	Total Extract	Del. S.B. Basin	Del. Colton & Riv N	Del. Outside SBVMWD	Total Extract	Del. S.B. Basin	Del. Colton & Riv N	Del. Outside SBVMWD	Total Extract	Del. S.B. Basin	Del. Colton & Riv N	Del. Outside SBVMWD
	(1)	(2)	(3)	(4)	(1)	(2)	(3)	(4)	(1)	(2)	(3)	(4)	(1)	(2)	(3)	(4)	(1)	(2)	(3)	(4)
PLAINTIFFS																				
CITY OF RIVERSIDE City & Riverside Wtr Co.	22,085	0	0	22,085	18,900	0	0	18,900	19,055	0	0	19,055	21,561	0	0	21,561	18,875	0	0	18,875
CITY OF RIVERSIDE Gage Canal Co.	29,289	0	523	28,766	32,099	0	346	31,753	26,329	646	301	25,382	30,816	0	415	30,401	31,881	383	-	31,498
SUB TOTAL - C of R	51,374	0	523	50,851	50,999	0	346	50,653	45,384	646	301	44,437	52,377	0	415	51,962	50,756	383	0	50,373
RIVERSIDE HIGHLAND WATER CO	4,520	0	2,051	2,469	3,583	0	1,820	1,763	1,350	0	1,051	299	3,369	0	1,782	1,587	3,677	0	2,060	1,617
MEEKS & DALEY WATER CO. AGUA MANSA WATER CO.	5,393	0	187	5,206	4,220	0	146	4,074	2,254	0	161	2,093	3,930	0	166	3,764	2,333	0	323	2,010
UNIVERSITY OF CALIFORNIA	245	0	0	245	87	0	0	87	183	0	0	183	83	0	0	83	7	0	0	7
TOTALS	61,532	0	2,761	58,771	58,889	0	2,312	56,577	49,171	646	1,513	47,012	59,759	0	2,363	57,396	56,773	383	2,383	54,007

Total Extract -- TOTAL EXTRACTIONS.
 Del S.B. Basin -- DELIVERIES IN SAN BERNARDINO BASIN AREA.
 Del. Colton & Riv. N. -- DELIVERIES IN COLTON & RIVERSIDE BASIN IN SAN BERNARDINO COUNTY.
 Del. Outside SBVMWD -- DELIVERIES OUTSIDE SAN BERNARDINO VALLEY MUNICIPAL WATER DISTRICT.

See Report of the Watermaster, same as Volume 5, Distribution of Extractions, Table 36-A

TABLE NO. 3

EXTRACTIONS BY PLAINTIFF
FROM THE SAN BERNARDINO BASIN AREA
FOR AVERAGE OF THE FIVE-YEAR PERIOD ENDING WITH 1963
AND CALENDAR YEARS 1971 THROUGH THE CURRENT YEAR

CLASSIFIED ACCORDING TO SERVICE AREA
 (Quantities in Acre Feet)

EXTRACTIONS FROM SAN BERNARDINO BASIN AREA FOR USE WITHIN AND EXPORT THEREFROM

PLAINTIFFS	1981				1982				1983				1984				1985			
	Total Extract	Del. S.B. Basin	Del. Colton & Riv N	Del. Outside SBVMWD	Total Extract	Del. S.B. Basin	Del. Colton & Riv N	Del. Outside SBVMWD	Total Extract	Del. S.B. Basin	Del. Colton & Riv N	Del. Outside SBVMWD	Total Extract	Del. S.B. Basin	Del. Colton & Riv N	Del. Outside SBVMWD	Total Extract	Del. S.B. Basin	Del. Colton & Riv N	Del. Outside SBVMWD
	(1)	(2)	(3)	(4)	(1)	(2)	(3)	(4)	(1)	(2)	(3)	(4)	(1)	(2)	(3)	(4)	(1)	(2)	(3)	(4)
CITY OF RIVERSIDE City & Riverside Wtr Co.	20,363	0	0	20,363	19,522	146	0	19,376	25,681	144	0	25,537	25,031	9	0	25,022	31,817	0	0	31,817
CITY OF RIVERSIDE Gage Canal Co.	31,794	724	-	31,070	30,077	16	-	30,061	20,383	191	-	20,192	33,875	32	-	33,843	31,256	59	-	31,197
SUB TOTAL - C of R	52,157	724	0	51,433	49,599	162	0	49,437	46,064	335	0	45,729	58,906	41	0	58,865	63,073	59	0	63,014
RIVERSIDE HIGHLAND WATER CO	3,604	0	2,148	1,456	2,795	0	1,776	1,019	3,162	0	2,319	843	4,759	0	2,671	2,088	3,312	0	1,978	1,334
MEEKS & DALEY WATER CO. AGUA MANSÁ WATER CO.	3,092	0	358	2,734	3,716	0	169	3,547	2,651	0	245	2,406	5,165	0	234	4,931	5,385	0	209	5,176
UNIVERSITY OF CALIFORNIA	143	0	0	143	48	0	0	48	0	0	0	0	0	0	0	0	0	0	0	0
TOTALS	58,996	724	2,506	55,766	56,158	162	1,944	54,052	51,877	335	2,565	48,977	68,830	41	2,905	65,884	71,770	59	2,188	69,523

Total Extract -- TOTAL EXTRACTIONS.
 Del S.B. Basin -- DELIVERIES IN SAN BERNARDINO BASIN AREA.
 Del. Colton & Riv. N. -- DELIVERIES IN COLTON & RIVERSIDE BASIN IN SAN BERNARDINO COUNTY.
 Del. Outside SBVMWD -- DELIVERIES OUTSIDE SAN BERNARDINO VALLEY MUNICIPAL WATER DISTRICT.

See Report of the Watermaster, same as Volume 5, Distribution of Extractions, Table 36-A

TABLE NO. 3

EXTRACTIONS BY PLAINTIFF
FROM THE SAN BERNARDINO BASIN AREA
FOR AVERAGE OF THE FIVE-YEAR PERIOD ENDING WITH 1963
AND CALENDAR YEARS 1971 THROUGH THE CURRENT YEAR

CLASSIFIED ACCORDING TO SERVICE AREA
 (Quantities in Acre Feet)

EXTRACTIONS FROM SAN BERNARDINO BASIN AREA FOR USE WITHIN AND EXPORT THEREFROM

PLAINTIFFS	1986				1987				1988				1989				1990			
	Total Extract	Del. S.B. Basin	Del. Colton & Riv N	Del. Outside SBVMWD	Total Extract	Del. S.B. Basin	Del. Colton & Riv N	Del. Outside SBVMWD	Total Extract	Del. S.B. Basin	Del. Colton & Riv N	Del. Outside SBVMWD	Total Extract	Del. S.B. Basin	Del. Colton & Riv N	Del. Outside SBVMWD	Total Extract	Del. S.B. Basin	Del. Colton & Riv N	Del. Outside SBVMWD
	(1)	(2)	(3)	(4)	(1)	(2)	(3)	(4)	(1)	(2)	(3)	(4)	(1)	(2)	(3)	(4)	(1)	(2)	(3)	(4)
CITY OF RIVERSIDE City & Riverside Wtr Co.	25,996	292	0	25,704	25,528	319	0	25,209	26,490	815	0	25,675	21,129	28	0	21,101	20,942	19	0	20,923
CITY OF RIVERSIDE Gage Canal Co.	33,983	145	-	33,838	32,313	15	-	32,298	38,022	0	-	38,022	29,655	0	-	29,655	26,695	0	-	26,695
SUB TOTAL - C of R	59,979	437	0	59,542	57,841	334	0	57,507	64,512	815	0	63,697	50,784	28	0	50,756	47,637	19	0	47,618
RIVERSIDE HIGHLAND WATER CO	4,744	0	2,128	2,616	3,919	0	2,229	1,690	4,775	0	2,229	2,546	4,681	0	1,968	2,713	4,092	0	2,313	1,779
MEEKS & DALEY WATER CO. AGUA MANSÁ WATER CO.	5,570	0	212	5,358	4,914	0	192	4,722	4,966	0	233	4,733	5,392	0	240	5,152	3,851	0	83	3,768
UNIVERSITY OF CALIFORNIA	48	0	0	48	195	0	0	195	179	0	0	179	62	0	0	62	95	0	0	95
TOTALS	70,341	437	2,341	67,563	66,869	334	2,421	64,114	74,432	815	2,461	71,156	60,919	28	2,208	58,683	55,675	19	2,397	53,259

Total Extract -- TOTAL EXTRACTIONS.
 Del S.B. Basin -- DELIVERIES IN SAN BERNARDINO BASIN AREA.
 Del. Colton & Riv. N. -- DELIVERIES IN COLTON & RIVERSIDE BASIN IN SAN BERNARDINO COUNTY.
 Del. Outside SBVMWD -- DELIVERIES OUTSIDE SAN BERNARDINO VALLEY MUNICIPAL WATER DISTRICT.

See Report of the Watermaster, same as Volume 5, Distribution of Extractions, Table 36-A

TABLE NO. 3

EXTRACTIONS BY PLAINTIFF
FROM THE SAN BERNARDINO BASIN AREA
FOR AVERAGE OF THE FIVE-YEAR PERIOD ENDING WITH 1963
AND CALENDAR YEARS 1971 THROUGH THE CURRENT YEAR

CLASSIFIED ACCORDING TO SERVICE AREA
 (Quantities in Acre Feet)

EXTRACTIONS FROM SAN BERNARDINO BASIN AREA FOR USE WITHIN AND EXPORT THEREFROM

PLAINTIFFS	1991				1992				1993				1994				1995			
	Total Extract	Del. S.B. Basin	Del. Colton & Riv N	Del. Outside SBVMWD	Total Extract	Del. S.B. Basin	Del. Colton & Riv N	Del. Outside SBVMWD	Total Extract	Del. S.B. Basin	Del. Colton & Riv N	Del. Outside SBVMWD	Total Extract	Del. S.B. Basin	Del. Colton & Riv N	Del. Outside SBVMWD	Total Extract	Del. S.B. Basin	Del. Colton & Riv N	Del. Outside SBVMWD
	(1)	(2)	(3)	(4)	(1)	(2)	(3)	(4)	(1)	(2)	(3)	(4)	(1)	(2)	(3)	(4)	(1)	(2)	(3)	(4)
CITY OF RIVERSIDE City & Riverside Wtr Co.	26,133	155	0	25,978	24,783	203	0	24,580	25,567	-108	0	25,675	25,724	7	0	25,717	23,316	1	0	23,315
CITY OF RIVERSIDE Gage Canal Co.	26,776	0	-	26,776	25,456	0	-	25,456	26,439	0	-	26,439	34,723	39	-	34,684	32,076	98	-	31,978
SUB TOTAL - C of R	52,909	155	0	52,754	50,239	203	0	50,036	52,006	-108	0	52,114	60,447	46	0	60,401	55,392	99	0	55,293
RIVERSIDE HIGHLAND WATER CO	3,021	0	1,669	1,352	4,052	0	2,275	1,777	3,241	0	1,777	1,464	4,324	0	2,201	2,123	3,955	0	2,146	1,809
MEEKS & DALEY WATER CO. AGUA MANSÁ WATER CO.	4,426	0	190	4,236	4,100	0	118	3,982	5,013	0	276	4,737	4,525	0	227	4,298	3,560	0	145	3,415
UNIVERSITY OF CALIFORNIA	23	0	0	23	32	0	0	32	536	0	0	536	593	0	0	593	588	0	0	588
TOTALS	60,379	155	1,859	58,365	58,423	203	2,393	55,827	60,796	-108	2,053	58,851	69,889	46	2,428	67,415	63,495	99	2,291	61,105

Total Extract -- TOTAL EXTRACTIONS.
 Del S.B. Basin -- DELIVERIES IN SAN BERNARDINO BASIN AREA.
 Del. Colton & Riv. N. -- DELIVERIES IN COLTON & RIVERSIDE BASIN IN SAN BERNARDINO COUNTY.
 Del. Outside SBVMWD -- DELIVERIES OUTSIDE SAN BERNARDINO VALLEY MUNICIPAL WATER DISTRICT.

See Report of the Watermaster, same as Volume 5, Distribution of Extractions, Table 36-A

TABLE NO. 3

EXTRACTIONS BY PLAINTIFF
FROM THE SAN BERNARDINO BASIN AREA
FOR AVERAGE OF THE FIVE-YEAR PERIOD ENDING WITH 1963
AND CALENDAR YEARS 1971 THROUGH THE CURRENT YEAR

CLASSIFIED ACCORDING TO SERVICE AREA
 (Quantities in Acre Feet)

EXTRACTIONS FROM SAN BERNARDINO BASIN AREA FOR USE WITHIN AND EXPORT THEREFROM

PLAINTIFFS	1996				1997				1998				1999				2000			
	Total Extract	Del. S.B. Basin	Del. Colton & Riv N	Del. Outside SBVMWD	Total Extract	Del. S.B. Basin	Del. Colton & Riv N	Del. Outside SBVMWD	Total Extract	Del. S.B. Basin	Del. Colton & Riv N	Del. Outside SBVMWD	Total Extract	Del. S.B. Basin	Del. Colton & Riv N	Del. Outside SBVMWD	Total Extract	Del. S.B. Basin	Del. Colton & Riv N	Del. Outside SBVMWD
	(1)	(2)	(3)	(4)	(1)	(2)	(3)	(4)	(1)	(2)	(3)	(4)	(1)	(2)	(3)	(4)	(1)	(2)	(3)	(4)
CITY OF RIVERSIDE City & Riverside Wtr Co.	29,351	268	0	29,083	27,621	486	0	27,135	24,210	0	0	24,210	25,435	0	0	25,435	28,257	0	0	28,257
CITY OF RIVERSIDE Gage Canal Co.	34,031	10	0	34,021	32,317	8	0	32,309	30,207	0	0	30,207	35,707	181	0	35,526	35,215	117	0	35,098
SUB TOTAL - C of R	63,382	278	0	63,104	59,938	494	0	59,444	54,417	0	0	54,417	61,142	181	0	60,961	63,472	117	0	63,355
RIVERSIDE HIGHLAND WATER CO	5,051	0	2,756	2,295	4,939	0	2,656	2,283	3,250	0	1,961	1,289	2,931	0	2,082	849	2,856	0	2,811	45
MEEKS & DALEY WATER CO. AGUA MANSA WATER CO.	3,912	0	194	3,718	4,165	0	137	4,028	3,828	0	210	3,618	6,289	0	90	6,199	3,832	0	352	3,480
UNIVERSITY OF CALIFORNIA	445	0	0	445	505	0	0	505	590	0	0	590	586	0	0	586	624	0	0	624
TOTALS	72,790	278	2,951	69,561	69,547	494	2,794	66,259	62,085	0	2,170	59,915	70,948	181	2,172	68,595	70,784	117	3,164	67,503

Total Extract -- TOTAL EXTRACTIONS.
 Del S.B. Basin -- DELIVERIES IN SAN BERNARDINO BASIN AREA.
 Del. Colton & Riv. N. -- DELIVERIES IN COLTON & RIVERSIDE BASIN IN SAN BERNARDINO COUNTY.
 Del. Outside SBVMWD -- DELIVERIES OUTSIDE SAN BERNARDINO VALLEY MUNICIPAL WATER DISTRICT.

Excludes High Groundwater Mitigation Project flows in CY 1999 and 2000

See Report of the Watermaster, same as Volume 5, Distribution of Extractions, Table 36-A

TABLE NO. 3

EXTRACTIONS BY PLAINTIFF
FROM THE SAN BERNARDINO BASIN AREA
FOR AVERAGE OF THE FIVE-YEAR PERIOD ENDING WITH 1963
AND CALENDAR YEARS 1971 THROUGH THE CURRENT YEAR

CLASSIFIED ACCORDING TO SERVICE AREA
 (Quantities in Acre Feet)

EXTRACTIONS FROM SAN BERNARDINO BASIN AREA FOR USE WITHIN AND EXPORT THEREFROM

PLAINTIFFS	2001				2002				2003				2004				2005			
	Total Extract	Del. S.B. Basin	Del. Colton & Riv N	Del. Outside SBVMWD	Total Extract	Del. S.B. Basin	Del. Colton & Riv N	Del. Outside SBVMWD	Total Extract	Del. S.B. Basin	Del. Colton & Riv N	Del. Outside SBVMWD	Total Extract	Del. S.B. Basin	Del. Colton & Riv N	Del. Outside SBVMWD	Total Extract	Del. S.B. Basin	Del. Colton & Riv N	Del. Outside SBVMWD
	(1)	(2)	(3)	(4)	(1)	(2)	(3)	(4)	(1)	(2)	(3)	(4)	(1)	(2)	(3)	(4)	(1)	(2)	(3)	(4)
CITY OF RIVERSIDE City & Riverside Wtr Co.	23,042	208	0	22,834	28,604	172	0	28,432	21,836	10	0	21,826	20,525	0	0	20,525	14,966	13	0	14,953
CITY OF RIVERSIDE Gage Canal Co.	36,270	21	0	36,249	36,858	0	0	36,858	32,678	0	0	32,678	32,889	0	0	32,889	29,730	0	0	29,730
SUB TOTAL - C of R	59,312	229	0	59,083	65,462	172	0	65,290	54,514	10	0	54,504	53,414	0	0	53,414	44,696	13	0	44,683
RIVERSIDE HIGHLAND (c) WATER CO	2,665	0	2,543	122	2,399	0	2,271	128	3,881	0	2,036	1,845	1,754	0	1,304	450	3,378	0	1,533	1,845
MEEKS & DALEY WATER CO. AGUA MANSÁ WATER CO.	3,671	0	192	3,479	5,800	0	202	5,598	7,440	0	49	7,391	3,782	0	19	3,763	5,891	0	4	5,887
UNIVERSITY OF CALIFORNIA	617	0	0	617	618	0	0	618	536	0	0	536	618	0	0	618	536	0	0	536
TOTALS	66,265	229	2,735	63,301	74,279	172	2,473	71,634	66,371	10	2,084	64,277	59,568	0	1,322	58,246	54,501	13	1,537	52,951

Total Extract -- TOTAL EXTRACTIONS.
 Del S.B. Basin -- DELIVERIES IN SAN BERNARDINO BASIN AREA.
 Del. Colton & Riv. N. -- DELIVERIES IN COLTON & RIVERSIDE BASIN IN SAN BERNARDINO COUNTY.
 Del. Outside SBVMWD -- DELIVERIES OUTSIDE SAN BERNARDINO VALLEY MUNICIPAL WATER DISTRICT.

Line c Excludes High Groundwater Mitigation Project flows in CY 2001
 Excludes High Groundwater Mitigation Project flows in CY 2002
 Excludes High Groundwater Mitigation Project flows in CY 2003

See Report of the Watermaster, same as Volume 5, Distribution of Extractions, Table 36-A

TABLE NO. 3

EXTRACTIONS BY PLAINTIFF
FROM THE SAN BERNARDINO BASIN AREA
FOR AVERAGE OF THE FIVE-YEAR PERIOD ENDING WITH 1963
AND CALENDAR YEARS 1971 THROUGH THE CURRENT YEAR

CLASSIFIED ACCORDING TO SERVICE AREA
 (Quantities in Acre Feet)

EXTRACTIONS FROM SAN BERNARDINO BASIN AREA FOR USE WITHIN AND EXPORT THEREFROM

PLAINTIFFS	2006				2007				2008				2009				2010			
	Total Extract	Del. S.B. Basin	Del. Colton & Riv N	Del. Outside SBVMWD	Total Extract	Del. S.B. Basin	Del. Colton & Riv N	Del. Outside SBVMWD	Total Extract	Del. S.B. Basin	Del. Colton & Riv N	Del. Outside SBVMWD	Total Extract	Del. S.B. Basin	Del. Colton & Riv N	Del. Outside SBVMWD	Total Extract	Del. S.B. Basin	Del. Colton & Riv N	Del. Outside SBVMWD
	(1)	(2)	(3)	(4)	(1)	(2)	(3)	(4)	(1)	(2)	(3)	(4)	(1)	(2)	(3)	(4)	(1)	(2)	(3)	(4)
CITY OF RIVERSIDE City & Riverside Wtr Co.	17,653	30	0	17,623	19,694	39	0	19,655	20,835	70	0	20,765	8,511	121	0	8,390	12,333	80	0	12,253
CITY OF RIVERSIDE Gage Canal Co.	31,791	0	0	31,791	32,324	0	0	32,324	32,746	0	0	32,746	34,550	0	0	34,550	33,380	0	0	33,380
SUB TOTAL - C of R	49,444	30	0	49,414	52,018	39	0	51,979	53,581	70	0	53,511	43,061	121	0	42,940	45,713	80	0	45,633
RIVERSIDE HIGHLAND WATER CO	4,149	0	2,304	1,845	3,633	0	1,772	1,861	2,730	0	2,054	676	1,648	0	1,073	575	1,136	0	629	507
MEEKS & DALEY WATER CO. AGUA MANSÁ WATER CO.	7,515	0	0	7,515	7,591	0	0	7,591	4,832	0	0	4,832	6,345	0	0	6,345	6,738	0	0	6,738
UNIVERSITY OF CALIFORNIA	536	-	-	536	536	-	-	536	536	-	-	536	536	-	-	536	536	-	-	536
TOTALS	61,644	30	2,304	59,310	63,778	39	1,772	61,967	61,679	70	2,054	59,555	51,590	121	1,073	50,396	54,123	80	629	53,414

Total Extract -- TOTAL EXTRACTIONS.
 Del S.B. Basin -- DELIVERIES IN SAN BERNARDINO BASIN AREA.
 Del. Colton & Riv. N. -- DELIVERIES IN COLTON & RIVERSIDE BASIN IN SAN BERNARDINO COUNTY.
 Del. Outside SBVMWD -- DELIVERIES OUTSIDE SAN BERNARDINO VALLEY MUNICIPAL WATER DISTRICT.

See Report of the Watermaster, same as Volume 5, Distribution of Extractions, Table 36-A

TABLE NO. 3

EXTRACTIONS BY PLAINTIFF
FROM THE SAN BERNARDINO BASIN AREA
FOR AVERAGE OF THE FIVE-YEAR PERIOD ENDING WITH 1963
AND CALENDAR YEARS 1971 THROUGH THE CURRENT YEAR

CLASSIFIED ACCORDING TO SERVICE AREA
 (Quantities in Acre Feet)

EXTRACTIONS FROM SAN BERNARDINO BASIN AREA FOR USE WITHIN AND EXPORT THEREFROM

PLAINTIFFS	2011				2012				2013				2014				2015			
	Total Extract	Del. S.B. Basin	Del. Colton & Riv N	Del. Outside SBVMWD	Total Extract	Del. S.B. Basin	Del. Colton & Riv N	Del. Outside SBVMWD	Total Extract	Del. S.B. Basin	Del. Colton & Riv N	Del. Outside SBVMWD	Total Extract	Del. S.B. Basin	Del. Colton & Riv N	Del. Outside SBVMWD	Total Extract	Del. S.B. Basin	Del. Colton & Riv N	Del. Outside SBVMWD
	(1)	(2)	(3)	(4)	(1)	(2)	(3)	(4)	(1)	(2)	(3)	(4)	(1)	(2)	(3)	(4)	(1)	(2)	(3)	(4)
CITY OF RIVERSIDE (a) City & Riverside Wtr Co.	16,697	72	0	16,625	16,384	13	0	16,371												
CITY OF RIVERSIDE (b) Gage Canal Co.	29,791	0	0	29,791	36,122	0	0	36,122												
SUB TOTAL - C of R	46,488	72	0	46,416	52,506	13	0	52,493												
RIVERSIDE HIGHLAND (c) WATER CO	1,655	0	1,087	568	2,135	0	1,523	612												
MEEKS & DALEY WATER CO. AGUA MANSÁ WATER CO. (d)	7,127	0	-	7,127	7,117	0	-	7,117												
UNIVERSITY OF CALIFORNIA (e)	536	-	-	536	536	-	-	536												
TOTALS	55,806	72	1,087	54,647	62,294	13	1,523	60,758												

Total Extract -- TOTAL EXTRACTIONS.
 Del S.B. Basin -- DELIVERIES IN SAN BERNARDINO BASIN AREA.
 Del. Colton & Riv. N. -- DELIVERIES IN COLTON & RIVERSIDE BASIN IN SAN BERNARDINO COUNTY.
 Del. Outside SBVMWD -- DELIVERIES OUTSIDE SAN BERNARDINO VALLEY MUNICIPAL WATER DISTRICT.

See Report of the Watermaster, same as Volume 5, Distribution of Extractions, Table 36-A

TABLE NO. 4
TOTAL EXTRACTIONS BY
PLAINTIFFS FROM SAN BERNARDINO BASIN AREA

TABLE NO. 4

page 1 of 2

TOTAL PLAINTIFF EXTRACTIONS FROM
SAN BERNARDINO BASIN AREA
 (Quantities in Acre Feet)

EXTRACTING PLAINTIFF

Year	City of Riverside (1)	Gage Canal (2)	Riverside Highland (3)	Meeks & Daley (4)	Univ. of California (5)	Total (6)
1959	25,983	31,805	4,745	7,282	558	70,373
1960	23,024	29,019	4,241	8,037	546	64,867
1961	24,682	30,670	5,535	9,399	658	70,944
1962	24,391	28,440	4,147	7,560	564	65,102
1963	22,379	26,999	3,326	7,854	425	60,983
5 YR AVERAGE	24,092	29,387	4,399	8,026	550	66,454
Adjusted Right		52,199	4,294	7,833	536	64,862
1971	24,939	28,943	4,012	2,902	219	61,015
1972	20,474	25,220	4,532	3,527	239	53,992
1973	21,493	21,529	3,512	2,979	239	49,752
1974	27,420	15,947	4,088	4,504	267	52,226
1975	25,248	22,714	4,709	3,950	179	56,800
1976	22,085	29,289	4,519	5,393	245	61,531
1977	18,900	32,099	3,583	4,220	87	58,888
1978	19,055	26,329	1,350	2,254	183	49,181
1979	21,561	30,816	3,369	3,930	83	59,759
1980	18,875	31,881	3,677	2,333	7	56,773
1981	20,363	31,794	3,604	3,092	143	58,996
1982	19,522	30,077	2,795	3,716	48	56,158
1983	25,681	20,383	3,161	2,651	0	51,876
1984	25,031	33,875	4,759	5,165	0	68,830
1985	31,817	31,256	3,312	5,385	0	71,770
1986	25,996	33,983	4,744	5,570	48	79,341
1987	25,528	32,313	3,919	4,914	195	66,869
1988	26,490	38,022	4,775	4,966	179	74,432
1989	21,129	29,655	4,681	5,392	62	60,919
1990	20,942	26,695	4,092	3,851	95	55,675
1991	26,133	26,776	3,021	4,426	23	60,379
1992	24,783	25,456	4,052	4,100	32	58,423
1993	25,675	26,439	3,241	5,013	536	60,904
1994	25,724	34,723	4,324	4,525	593	69,889
1995	23,316	32,076	3,955	3,560	588	63,495
1996	29,351	34,031	5,051	3,912	445	72,790
1997	27,621	32,317	4,939	4,165	505	69,547
1998	24,210	30,207	3,250	3,828	590	62,085
1999	25,435	35,707	2,931	6,289	586	70,948
2000	28,257	35,215	2,856	3,832	624	70,784
2001	23,042	36,270	2,665	3,671	617	66,265
2002	28,604	36,858	2,399	5,800	618	74,279
2003	21,836	32,678	3,881	7,440	536	66,371
2004	20,525	32,889	1,754	3,782	618	59,568
2005	14,966	29,730	3,378	5,891	536	54,501

From Table No. 3; same as Volume 5, Table 36-B

Adjusted Right, Annual Report Table No. 3

TABLE NO. 4

TOTAL PLAINTIFF EXTRACTIONS FROM
SAN BERNARDINO BASIN AREA
 (Quantities in Acre Feet)

EXTRACTING PLAINTIFF

Year	City of Riverside	Gage Canal	Riverside Highland	Meeks & Daley	Univ. of California	Total
	(1)	(2)	(3)	(4)	(5)	(6)
1959	25,983	31,805	4,745	7,282	558	70,373
1960	23,024	29,019	4,241	8,037	546	64,867
1961	24,682	30,670	5,535	9,399	658	70,944
1962	24,391	28,440	4,147	7,560	564	65,102
1963	22,379	26,999	3,326	7,854	425	60,983
5 YR AVERAGE	24,092	29,387	4,399	8,026	550	66,454
Adjusted Right		52,199	4,294	7,833	536	64,862
2006	17,653	31,791	4,149	7,515	536	61,644
2007	19,694	32,324	3,633	7,591	536	63,778
2008	20,835	32,746	2,730	4,832	536	61,679
2009	8,511	34,550	1,648	6,345	536	51,590
2010	12,333	33,380	1,136	6,738	536	54,123
2011	16,697	29,791	1,655	7,127	536	55,806
2012	16,384	36,122	2,135	7,117	536	62,294
2013						
2014						
2015						
2016						
2017						
2018						
2019						
2020						
2021						
2022						
2023						
2024						
2025						
2026						
2027						
2028						
2029						
2030						
2031						
2032						
2033						
2034						
2035						
2036						
2037						
2038						
2039						
2040						

From Table No. 3; same as Volume 5, Table 36-B

Adjusted Right, Annual Report Table No. 3

TABLE NO. 5
EXTRACTIONS BY PLAINTIFFS FROM
THE SAN BERNARDINO BASIN AREA
FOR DELIVERIES IN SAN BERNARDINO BASIN AREA

TABLE NO. 5

page 1 of 2

EXTRACTIONS BY PLAINTIFFS FROM
THE SAN BERNARDINO BASIN AREA FOR DELIVERIES IN
SAN BERNARDINO BASIN AREA
(Quantities in Acre Feet)

Year	City of Riverside	Gage Canal	Riverside Highland	Meeks & Daley	Univ. of California	Total
	(1)	(2)	(3)	(4)	(5)	(6)
1959	2,369	501	0	0	0	2,870
1960	2,006	539	0	0	0	2,545
1961	0	461	0	0	0	461
1962	0	751	0	0	0	751
1963	0	683	0	0	0	683
5 YR AVERAGE	875	587	0	0	0	1,462
Adjusted Right		1,427	0	0	0	1,427
1971	0	98	0	0	0	98
1972	0	85	0	0	0	85
1973	0	156	0	0	0	156
1974	0	0	0	0	0	0
1975	0	0	0	0	0	0
1976	0	0	0	0	0	0
1977	0	0	0	0	0	0
1978	0	646	0	0	0	646
1979	0	0	0	0	0	0
1980	0	383	0	0	0	383
1981	0	724	0	0	0	724
1982	146	16	0	0	0	162
1983	144	191	0	0	0	335
1984	0	32	0	0	0	32
1985	0	59	0	0	0	59
1986	292	145	0	0	0	437
1987	319	15	0	0	0	334
1988	815	0	0	0	0	815
1989	28	0	0	0	0	28
1990	19	0	0	0	0	19
1991	155	0	0	0	0	155
1992	203	0	0	0	0	203
1993	-108	0	0	0	0	-108
1994	7	39	0	0	0	46
1995	1	98	0	0	0	99
1996	268	10	0	0	0	278
1997	486	8	0	0	0	494
1998	0	0	0	0	0	0
1999	0	181	0	0	0	181
2000	0	117	0	0	0	117
2001	208	21	0	0	0	229
2002	172	0	0	0	0	172
2003	10	0	0	0	0	10
2004	0	0	0	0	0	0
2005	13	0	0	0	0	13

From Table No. 3; same as Volume 5, Table 36-C

Adjusted Right, Annual Report Table No. 3

TABLE NO. 5

EXTRACTIONS BY PLAINTIFFS FROM
THE SAN BERNARDINO BASIN AREA FOR DELIVERIES IN
SAN BERNARDINO BASIN AREA
 (Quantities in Acre Feet)

Year	City of Riverside (1)	Gage Canal (2)	Riverside Highland (3)	Meeks & Daley (4)	Univ. of California (5)	Total (6)
1959	2,369	501	0	0	0	2,870
1960	2,006	539	0	0	0	2,545
1961	0	461	0	0	0	461
1962	0	751	0	0	0	751
1963	0	683	0	0	0	683
5 YR AVERAGE	875	587	0	0	0	1,462
Adjusted Right		1,427	0	0	0	1,427
2006	30	-	-	-	-	30
2007	39	-	-	-	-	39
2008	70	-	-	-	-	70
2009	121	-	-	-	-	121
2010	80	-	-	-	-	80
2011	72	-	-	-	-	72
2012	13	-	-	-	-	13
2013		-	-	-	-	
2014		-	-	-	-	
2015		-	-	-	-	
2016		-	-	-	-	
2017		-	-	-	-	
2018		-	-	-	-	
2019		-	-	-	-	
2020		-	-	-	-	
2021		-	-	-	-	
2022		-	-	-	-	
2023		-	-	-	-	
2024		-	-	-	-	
2025		-	-	-	-	
2026		-	-	-	-	
2027		-	-	-	-	
2028		-	-	-	-	
2029		-	-	-	-	
2030		-	-	-	-	
2031		-	-	-	-	
2032		-	-	-	-	
2033		-	-	-	-	
2034		-	-	-	-	
2035		-	-	-	-	
2036		-	-	-	-	
2037		-	-	-	-	
2038		-	-	-	-	
2039		-	-	-	-	
2040		-	-	-	-	

From Table No. 3; same as Volume 5, Table 36-C
 Adjusted Right, Annual Report Table No. 3

TABLE NO. 6
EXTRACTIONS BY PLAINTIFFS FROM
THE SAN BERNARDINO BASIN AREA
FOR DELIVERIES IN COLTON AND
RIVERSIDE BASINS IN SAN BERNARDINO COUNTY

TABLE NO. 6

page 1 of 2

EXTRACTIONS BY PLAINTIFFS FROM
THE SAN BERNARDINO BASIN AREA FOR DELIVERIES IN
COLTON & RIVERSIDE BASINS IN SAN BERNARDINO COUNTY

(Quantities in Acre Feet)

Year	City of Riverside	Gage Canal	Riverside Highland	Meeks & Daley	Univ. of California	Total
	(1)	(2)	(3)	(4)	(5)	(6)
1959	382	1001	2,561	295	0	4,239
1960	356	892	2,352	312	0	3,912
1961	338	1010	3,026	363	0	4,737
1962	345	783	2,569	363	0	4,060
1963	435	758	2,037	297	0	3,527
5 YR AVERAGE	371	889	2,509	326	0	4,095
Adjusted Right		1,230	2,449	318	0	3,997
1971	0	669	2,388	383	0	3,440
1972	0	547	2,239	377	0	3,163
1973	0	512	1,751	250	0	2,513
1974	65	485	1,985	246	0	2,781
1975	0	575	2,002	168	0	2,745
1976	0	523	2,050	182	0	2,755
1977	0	346	1,820	146	0	2,312
1978	0	301	1,051	161	0	1,513
1979	0	415	1,781	166	0	2,362
1980	0	0	2,060	323	0	2,383
1981	0	0	2,151	358	0	2,509
1982	0	0	1,775	169	0	1,944
1983	0	0	2,318	245	0	2,563
1984	0	0	2,671	233	0	2,904
1985	0	0	1,978	210	0	2,188
1986	0	0	2,130	234	0	2,364
1987	0	0	2,229	193	0	2,422
1988	0	0	2,229	233	0	2,462
1989	0	0	1,968	240	0	2,208
1990	0	0	2,313	83	0	2,396
1991	0	0	1,669	190	0	1,859
1992	0	0	2,275	118	0	2,393
1993	0	0	1,777	276	0	2,053
1994	0	0	2,201	227	0	2,428
1995	0	0	2,146	145	0	2,291
1996	0	0	2,756	194	0	2,951
1997	0	0	2,656	137	0	2,794
1998	0	0	1,961	210	0	2,170
1999	0	0	2,082	90	0	2,172
2000	0	0	2,811	352	0	3,164
2001	0	0	2,543	192	0	2,735
2002	0	0	2,271	202	0	2,473
2003	0	0	2,036	49	0	2,084
2004	0	0	1,304	19	0	1,322
2005	0	0	1,533	4	0	1,537

From Table No. 3; same as Volume 5, Table 36-D

Adjusted Right, Annual Report Table No. 3

TABLE NO. 6

EXTRACTIONS BY PLAINTIFFS FROM
THE SAN BERNARDINO BASIN AREA FOR DELIVERIES IN
COLTON & RIVERSIDE BASINS IN SAN BERNARDINO COUNTY

(Quantities in Acre Feet)

Year	City of Riverside	Gage Canal	Riverside Highland	Meeks & Daley	Univ. of California	Total
	(1)	(2)	(3)	(4)	(5)	(6)
1959	382	1001	2,561	295	0	4,239
1960	356	892	2,352	312	0	3,912
1961	338	1010	3,026	363	0	4,737
1962	345	783	2,569	363	0	4,060
1963	435	758	2,037	297	0	3,527
5 YR AVERAGE	371	889	2,509	326	0	4,095
Adjusted Right		1,230	2,449	318	0	3,997
2006	0	-	2,304	0	-	2,304
2007	0	-	1,772	0	-	1,772
2008	0	-	2,054	-	-	2,054
2009	0	-	1,073	-	-	1,073
2010	0	-	629	-	-	629
2011	0	-	1,087	-	-	1,087
2012	0	-	1,523	-	-	1,523
2013		-		-	-	
2014		-		-	-	
2015		-		-	-	
2016		-		-	-	
2017		-		-	-	
2018		-		-	-	
2019		-		-	-	
2020		-		-	-	
2021		-		-	-	
2022		-		-	-	
2023		-		-	-	
2024		-		-	-	
2025		-		-	-	
2026		-		-	-	
2027		-		-	-	
2028		-		-	-	
2029		-		-	-	
2030		-		-	-	
2031		-		-	-	
2032		-		-	-	
2033		-		-	-	
2034		-		-	-	
2035		-		-	-	
2036		-		-	-	
2037		-		-	-	
2038		-		-	-	
2039		-		-	-	
2040		-		-	-	

From Table No. 3; same as Volume 5, Table 36-D

Adjusted Right, Annual Report Table No. 3

TABLE NO. 7
EXTRACTIONS BY PLAINTIFFS FROM
THE SAN BERNARDINO BASIN AREA FOR
DELIVERIES OUTSIDE SAN BERNARDINO VALLEY

TABLE NO. 7

page 1 of 2

EXTRACTIONS BY PLAINTIFFS FROM
THE SAN BERNARDINO BASIN AREA FOR DELIVERIES
OUTSIDE SAN BERNARDINO VALLEY
(Quantities in Acre Feet)

Year	City of Riverside (1)	Gage Canal (2)	Riverside Highland (3)	Meeks & Daley (4)	Univ. of California (5)	Total (6)
1959	23,232	30,303	2,184	6,987	558	63,264
1960	20,662	27,588	1,889	7,725	546	58,410
1961	24,344	29,199	2,509	9,036	658	65,746
1962	24,046	26,906	1,578	7,197	564	60,291
1963	21,944	25,558	1,289	7,557	425	56,773
5 YR AVERAGE	22,846	27,911	1,890	7,700	550	60,897
Adjusted Right		49,542	1,845	7,515	536	59,438
1971	24,939	28,176	1,624	2,519	219	57,477
1972	20,474	24,588	2,293	3,150	239	50,744
1973	21,493	20,861	1,761	2,729	239	47,083
1974	27,355	15,462	2,103	4,258	267	49,445
1975	25,248	22,139	2,707	3,783	179	54,056
1976	22,085	28,766	2,469	5,211	245	58,776
1977	18,900	31,753	1,763	4,074	87	56,577
1978	19,055	25,382	299	2,093	183	47,012
1979	21,561	30,401	1,588	3,764	83	57,397
1980	18,875	31,498	1,617	2,010	7	54,007
1981	20,363	31,070	1,453	2,734	143	55,763
1982	19,376	30,061	1,020	3,547	48	54,052
1983	25,537	20,192	843	2,406	0	48,978
1984	25,031	33,843	2,088	4,932	0	65,894
1985	31,817	31,197	1,334	5,175	0	69,523
1986	25,704	33,838	2,614	5,336	48	67,540
1987	25,209	32,298	1,690	4,721	195	64,113
1988	25,675	38,022	2,546	4,733	179	71,155
1989	21,101	29,655	2,713	5,152	62	58,683
1990	20,923	26,695	1,779	3,768	95	53,260
1991	25,978	26,776	1,352	4,236	23	58,365
1992	24,580	25,456	1,777	3,982	32	55,827
1993	25,783	26,439	1,464	4,737	536	58,959
1994	25,717	34,684	2,123	4,298	593	67,415
1995	23,315	31,978	1,809	3,415	588	61,105
1996	29,083	34,021	2,295	3,718	445	69,561
1997	27,135	32,309	2,283	4,028	505	66,259
1998	24,210	30,207	1,289	3,618	590	59,915
1999	25,435	35,526	849	6,199	586	68,595
2000	28,257	35,098	45	3,480	624	67,503
2001	22,834	36,249	122	3,479	617	63,301
2002	28,432	36,858	128	5,598	618	71,634
2003	21,826	32,678	1,845	7,391	536	64,277
2004	20,525	32,889	450	3,763	618	58,246
2005	14,953	29,730	1,845	5,887	536	52,951

From Table No. 3; same as Table 36-E, Volume 5.

Adjusted Right, Annual Report Table No. 3

TABLE NO. 7

EXTRACTIONS BY PLAINTIFFS FROM
THE SAN BERNARDINO BASIN AREA FOR DELIVERIES
OUTSIDE SAN BERNARDINO VALLEY
 (Quantities in Acre Feet)

Year	City of Riverside	Gage Canal	Riverside Highland	Meeks & Daley	Univ. of California	Total
	(1)	(2)	(3)	(4)	(5)	(6)
1959	23,232	30,303	2,184	6,987	558	63,264
1960	20,662	27,588	1,889	7,725	546	58,410
1961	24,344	29,199	2,509	9,036	658	65,746
1962	24,046	26,906	1,578	7,197	564	60,291
1963	21,944	25,558	1,289	7,557	425	56,773
5 YR AVERAGE	22,846	27,911	1,890	7,700	550	60,897
Adjusted Right		49,542	1,845	7,515	536	59,438
2006	17,623	31,791	1,845	7,515	536	59,310
2007	19,655	32,324	1,861	7,591	536	61,967
2008	20,765	32,746	676	4,832	536	59,555
2009	8,390	34,550	575	6,345	536	50,396
2010	12,253	33,380	507	6,738	536	53,414
2011	16,625	29,791	568	7,127	536	54,647
2012	16,371	36,122	612	7,117	536	60,758
2013						
2014						
2015						
2016						
2017						
2018						
2019						
2020						
2021						
2022						
2023						
2024						
2025						
2026						
2027						
2028						
2029						
2030						
2031						
2032						
2033						
2034						
2035						
2036						
2037						
2038						
2039						
2040						

From Table No. 3; same as Table 36-E, Volume 5.

Adjusted Right, Annual Report Table No. 3

**WESTERN - SAN BERNARDINO WATERMASTER
FOR
WESTERN MUNICIPAL WATER DISTRICT et al.
vs.
EAST SAN BERNARDINO COUNTY WATER DISTRICT et al.
CASE NO. 78426 - COUNTY OF RIVERSIDE**

VOLUME 2 - 2012

**VERIFIED EXTRACTIONS FROM THE
COLTON BASIN AREA
FOR
CALENDAR YEARS 1959-1963 & 2008-2012**

**ANNUAL ACCOUNTING
FOR INDIVIDUAL WELLS**

April 1, 2014

WATERMASTER
Douglas D. Headrick
John V. Rossi

REPORT OF WATERMASTER

Western Municipal Water District of Riverside County, et al.
Plaintiffs

vs.

East San Bernardino County Water District, et al.
Defendants

Superior Court of Riverside County

Case No. 78426

VOLUME 2 - 2012

VERIFIED EXTRACTIONS FROM

COLTON BASIN AREA

for

CALENDAR YEARS 1959-1963 & 2008-2012

ANNUAL ACCOUNTING

FOR INDIVIDUAL WELLS

April 1, 2014

WATERMASTER

Douglas D. Headrick
John V. Rossi

VOLUME 1A - 2012

TABLE OF CONTENTS

<u>CHAPTER I</u>	<u>PAGE</u>
PLAINTIFFS EXTRACTIONS FROM THE SAN BERNARDINO BASIN AREA FOR CALENDAR YEARS 1959-1963 AND 2008-2012	i
 <u>CHAPTER II</u>	
PLAINTIFFS EXTRACTIONS FROM THE SAN BERNARDINO BASIN AREA FOR CALENDAR YEARS 1959-1963 AND 2008-2012 AND DISTRIBUTION BY SERVICE AREA	iii
 MAP - SAN BERNARDINO BASIN AREA - PLAINTIFFS	 1
GRAPH - VERIFIED WATER PRODUCTION BY PLAINTIFFS IN THE SAN BERNARDINO BASIN AREA FOR CALENDAR YEARS 1959-63 and 1971 THROUGH PRESENT	 2
SAN BERNARDINO BASIN AREA, CROSS INDEX BY OWNER - PLAINTIFFS	 3
SAN BERNARDINO BASIN AREA, CROSS INDEX BY STATE WELL NUMBER - PLAINTIFFS	 8
SAN BERNARDINO BASIN AREA, CROSS INDEX BY RECORDATION NUMBER - PLAINTIFFS	 13
 <u>TABLE NO. 1</u>	
VERIFIED EXTRACTIONS BY OWNERS (PLAINTIFFS) WHICH HAVE FILINGS WITH THE WATERMASTER FOR SAN BERNARDINO BASIN AREA	 18
 <u>TABLE NO. 2</u>	
SUMMARY OF EXTRACTIONS (FILED AND NON-FILED BY ALL PLAINTIFFS) FOR SAN BERNARDINO BASIN AREA	 24

TABLE NO. 3

EXTRACTIONS BY PLAINTIFFS FROM THE SAN BERNARDINO
BASIN AREA FOR AVERAGE OF FIVE-YEAR PERIOD ENDING
WITH 1963 AND CALENDAR YEARS 1971 THROUGH CURRENT
YEAR CLASSIFIED ACCORDING TO SERVICE AREA 26

TABLE NO. 4

TOTAL EXTRACTIONS BY PLAINTIFFS FROM
SAN BERNARDINO BASIN AREA 37

TABLE NO. 5

EXTRACTIONS BY PLAINTIFFS FROM THE SAN BERNARDINO BASIN
AREA FOR DELIVERIES IN SAN BERNARDINO BASIN AREA 40

TABLE NO. 6

EXTRACTIONS BY PLAINTIFFS FROM THE SAN BERNARDINO
BASIN AREA FOR DELIVERIES IN COLTON AND RIVERSIDE
BASINS IN SAN BERNARDINO COUNTY 43

TABLE NO. 7

EXTRACTIONS BY PLAINTIFFS FROM THE SAN BERNARDINO
BASIN AREA FOR DELIVERIES OUTSIDE SAN BERNARDINO
VALLEY. 46

VOLUME 1A - 2012

CHAPTER I

PLAINTIFFS EXTRACTIONS FROM THE
SAN BERNARDINO BASIN AREA FOR
CALENDAR YEARS 1959-1963 AND 2008-2012

The provisions of Paragraph IV (B,3) of the Judgment in Case No. 78426 entered April 17, 1969, entitled "San Bernardino Basin Area Rights and Replenishment (Annual Adjusted Rights of Plaintiffs)" provides as follows:

VI(B,3) "In any five-year period, each Plaintiff shall have the right to extract from the San Bernardino Basin area for use in each service area designated in Table B-1 an amount of water equal to five times its adjusted right for such service area; provided, however, that extractions by each Plaintiff in any year in any service area shall not exceed such Plaintiff's adjusted right for that service area by more than 30 percent."

Compliance with this provision of the Judgment requires that an accounting of the total actual extractions of surface and groundwater by the Plaintiffs-City of Riverside, The Gage Canal Co., Meeks & Daley Water Co., Agua Mansa Water Co., Riverside Highland Water Co., and the Regents of the University of California-from the San Bernardino Basin Area be made annually. Included in this Volume 1A-2012 is the verified accounting of such extractions by the Plaintiffs for the Calendar years 2008 through 2012. The extractions for the five-year base period ending with 1963 are also included for comparison.

Three indexes are included which provide a cross index by owner's name, State Water Resources Control Board Well Recordation Number, and State Well Number. Each index shows, in addition, the local designation of each well, if the State has closed the file, which year that occurred, the last 5 years verified extractions and the average for those years.

The individual wells of each owner are listed in Table No. 1, showing the extractions from each well for each year in the five-year base period ending in 1963, the base period average, and the extractions for the years 2008-2012.

Table No. 2 summarizes, by owner, the total annual extractions for the base period and base period average, together with the annual extractions years 2008-2012 and that 5 year period. The total annual extractions for 2012 are 62,294 acre feet.

CHAPTER II

PLAINTIFFS EXTRACTIONS FROM THE SAN BERNARDINO BASIN AREA FOR CALENDAR YEARS 1959-1963 AND 2008-2012 AND DISTRIBUTION BY SERVICE AREA

Paragraph XVI of the Judgment states:

"The provisions of Paragraph 3 and 5 through 12 of this Judgment shall be in effect from and after January 1, 1971; and remaining provisions are in effect immediately."

Thus the annual accounting provisions which relate to extractions from the San Bernardino Basin Area by Plaintiffs were not effective until January 1, 1971.

Table No. 1 and 1A of Chapter I shows the extractions from individual wells owned by each Plaintiff for the five calendar year period ending with 1963, the annual average for said five-year period, and the extractions for the calendar years 2008 through 2012 and the annual average for that period. Table No. 2 described in Chapter I summarizes the total annual extractions for each Plaintiff during the five-year period 1959 through 1963, the annual average for the five-year period, and the 2008 through 2012 extractions and the annual average.

Table No. 3 shows total annual extractions and its distribution.

To facilitate the comparison of the total annual extractions as well as the portions thereof delivered within the San Bernardino Basin Area, the Colton Basin and Riverside Basin within San Bernardino County, and to areas outside San Bernardino Valley, four additional tables have been prepared which summarize the total annual extractions from the San Bernardino Basin Area for the period 1959 through 1963 and 1971 through the current year for each Plaintiff, as well as the portions thereof delivered to various service areas described above.

Table No. 4 lists the Total Extractions from the San Bernardino Basin Area for each Plaintiff annually for the period 1959 through 1963 and the five-year average and calendar years 1971 through the current year.

Similar listings were made for the same period which shows the deliveries within the San Bernardino Basin Area, the deliveries to Colton and Riverside Basins within San Bernardino County, and the deliveries to areas outside San Bernardino Valley. These listings are shown on Tables No. 5, 6, and 7 respectively.

ERRATA

Volume 1A, Bunker Hill Basin
Plaintiffs

During the 2012 Verification, July 2013, the following changes were made to the report.

No changes were made

During the 2011 Verification, July 2012, the following changes were made to the report.

The following 2 wells were **closed** during the year

3601219, Riverside City of, Raub 2, 01S/04W-23C02S, noted abandoned on 2011 filing
3601239, Riverside City of, Raub 3, 01S/04W-14P06S, noted abandoned on 2011 filing

During the 2010 Verification, July 2011, the following corrections were made to the report.

The following 2 new wells were **added** to the files this year

3603950, Meeks & Daley Mutual Water Company, Sperry Well, 01S/04W-21L05S. replaces #36 well which was abandoned.
3603951, Meeks & Daley Water Company, Raub #7 Lease, 01S/04W-23C06S, same as Riverside 3603929.

During the 2009 verification, November 2010, the following corrections were made to the report.

The following 3 new wells were **added** to the files this year

3603931, University of California Riverside, Cooley H Lease, 01S/04W-11D02S,
same well as 3601228 and 3603911
3603939, Meeks & Daley, Garner 6 Lease, 01S/04W-02P09S
same as City of Riverside 3603254
3603940, Meeks & Daley, Garner 7 Lease, 01S/04W-02Q11S
same as City of Riverside 3302794

The following **corrections or additions** were made during the year

3603930, City of Riverside, Raub #7, 01S/04W-23C06S full sw#
received from DWR 02/22/10

The following **back-filings/corrected filing** were made during the year

3602423, Riverside - Gage Canal, #6 domestic, corrected
filings from new pump test (with substantial drop in
water level - way off pump curve)
2008 corrected from 16 AF to 3 AF, -13 AF
2007 corrected from 27 AF to 5 AF, -23 AF
2006 corrected from 31 AF to 6 AF, -25 AF

3302794, City of Riverside, Garner 7, 01S/04W-02Q11S was
re-assigned to 3603948. Well was mis-assigned a
Riverside County "33" recordation number in 1996

3303122, Dr Erik Melchiorre, Ag well, 02S/03W-07N,
backfiled on First Notice

2008	0.1 AF
2007	0.1 AF
2006	0.1 AF
2005	0.1 AF
2004	0.1 AF
2003	0.1 AF
2002	0.1 AF
2001	0.1 AF
2000	0.1 AF

3603910, Montecito Memorial Park, Well #3 Barton RD,
01S/04W-27Q, Due to an error in assigning "managing
agency" within the GWDM, this well was not shown in
Volume 3 previous to the 2009 report

2007	0 AF
2008	175 AF

3603946, West Valley Water District, Well #54, 01N/06W-
24C01S. Due to an error in assigning "managing agency"
within the GWDM, this well was not shown in Volume 3
previous to the 2009 report.

2005	0 AF
2006	0 AF
2007	1,021 AF
2008	795 AF

During the 2008 verification, (October 2009) no changes or
corrections were made to the report.

During the 2007 verification, (October 2008) no changes or
corrections were made to the report.

During the 2006 verification, (March 2008) no changes or
corrections were made to the report.








During the 2005 verification, (May 2007) no changes or
corrections were made to the report.

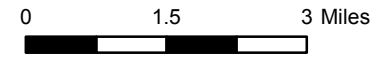
During the 2004 verification, (June 2006) the following changes
and corrections were made to the report,

New wells
City of Colton, #24 (3604008)

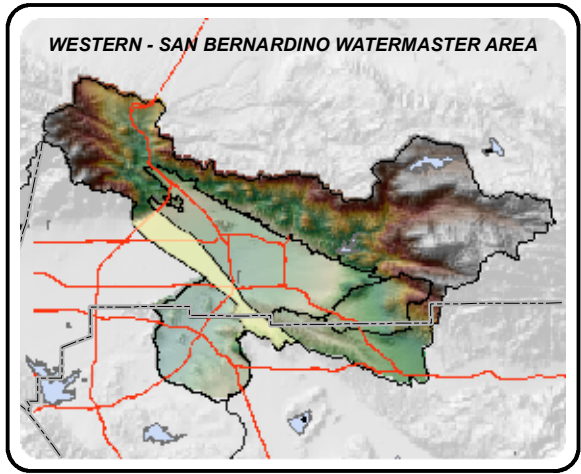
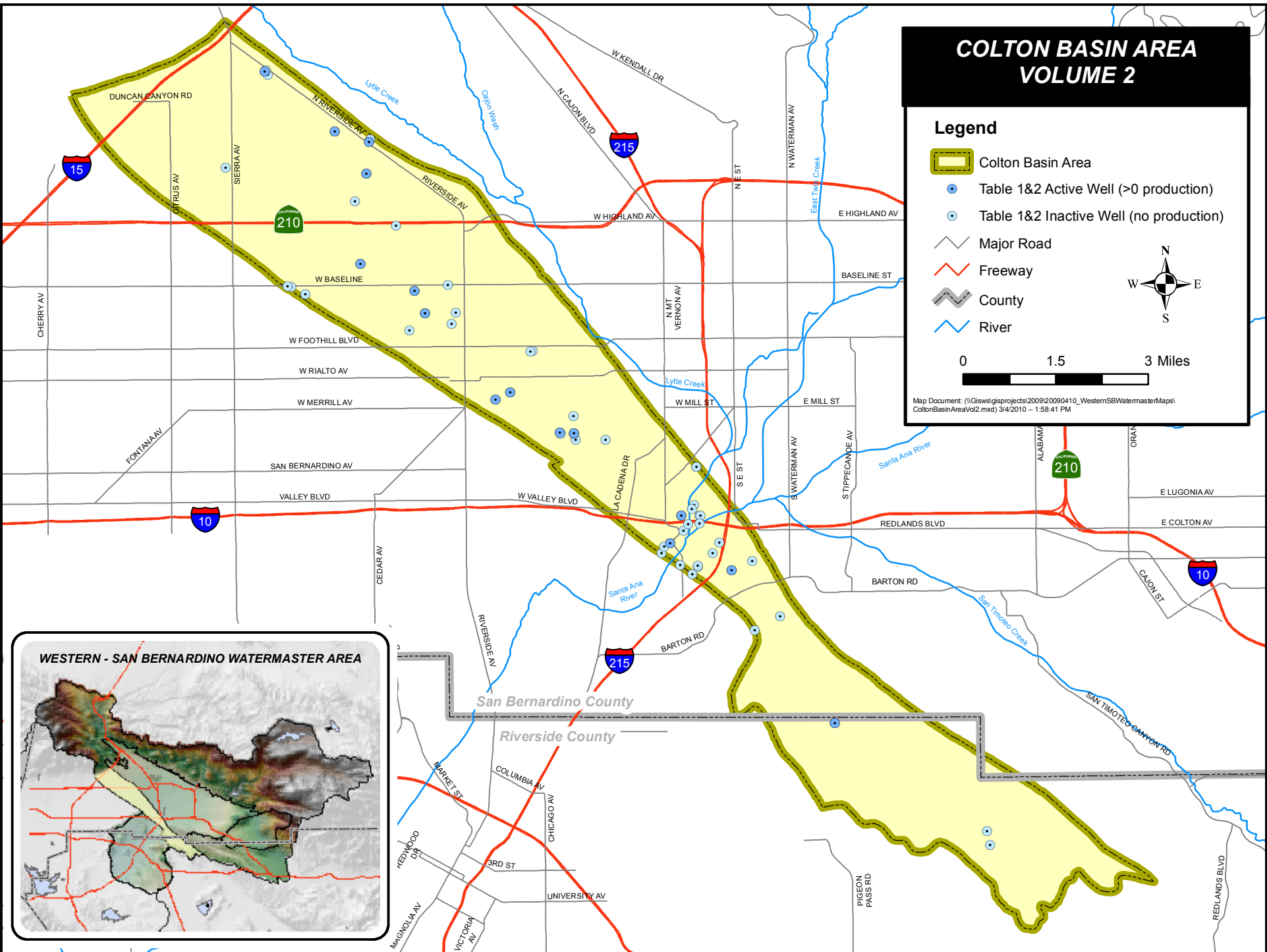
COLTON BASIN AREA VOLUME 2

Legend

-  Colton Basin Area
-  Table 1&2 Active Well (>0 production)
-  Table 1&2 Inactive Well (no production)
-  Major Road
-  Freeway
-  County
-  River

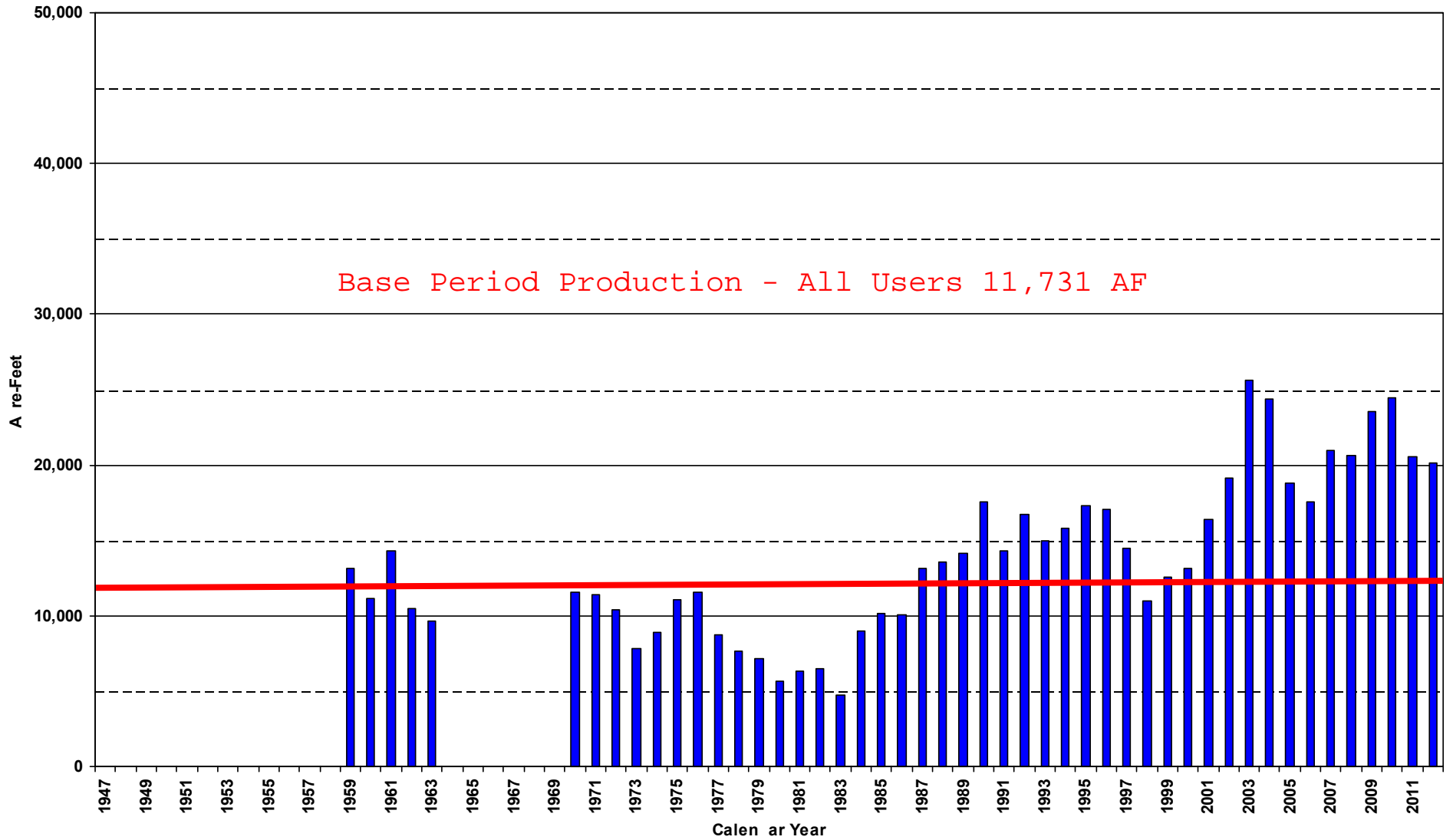


Map Document: (\\GIS\swg\projects\2009\20090410_WesternSBWatermaster\Maps\ColtonBasinAreaVol2.mxd) 3/4/2010 - 1:58:41 PM



WESTERN - SAN BERNARDINO WATERMASTER

COLTON BASIN



COLTON BASIN AREA
CROSS INDEX BY OWNER

**WESTERN - SAN BERNARDINO WATERMASTER
VERIFIED PRODUCTION DATA
CROSS INDEX BY OWNER
COLTON BASIN**

OWNER	WELL TYPE	RECRDTN NUMBER	STATE WELL NUMBER	LOCAL DESIGNATION	YEAR CLOSED	-----CALENDAR YEAR EXTRACTIONS-----					
						2008	2009	2010	2011	2012	AVG
COLTON, CITY OF	W	3601255	01S/04W-18B	9	1982	0	0	0	0	0	0
COLTON, CITY OF	W	3601259	01S/04W-18G01S	15		537	539	650	467	607	560
COLTON, CITY OF	W	3601261	01S/04W-18F01S	17		1,414	1,053	1,304	1,321	1,152	1,249
COLTON, CITY OF	W	3602255	01S/04W-27L01S	KATZ/HOLLOW		0	0	0	0	0	0
COLTON, CITY OF	W	3602356	01S/04W-34H	5731- JAMES SULLIVAN		0	0	0	0	0	0
COLTON, CITY OF	W	3602881	01S/04W-27L03S	22		328	5	423	610	335	340
COLTON, CITY OF	W	3603367	01S/04W-21K01S	#23		1,684	1,683	1,543	965	764	1,328
COLTON, CITY OF	W	3603916	01S/04W-08Q04S	#29		0	0	0	0	0	0
FONTANA UNION WATER COMPANY	W	3600577	01S/05W-05A03S	22	2002	0	0	0	0	0	0
FONTANA UNION WATER COMPANY	W	3600578	01S/05W-05A02S	23	1980	0	0	0	0	0	0
FONTANA UNION WATER COMPANY	W	3600589	01S/05W-04D01S	35	1989	0	0	0	0	0	0
FONTANA UNION WATER COMPANY	W	3602129	01N/05W-30A	36	1980	0	0	0	0	0	0
FONTANA UNION WATER COMPANY	W	3603060	01N/05W-29R15S	F13A (OLD FU #37)		768	1,828	1,477	1,629	1,590	1,458
FONTANA UNION WATER COMPANY	W	3603726	01N/06W-25A01S	F15A		1,184	1,608	1,369	1,007	1,053	1,244
FONTANA UNION WATER COMPANY	W	3603739	01N/05W-32A02S	F13B		1,617	1,990	1,851	1,411	1,124	1,599
FONTANA UNION WATER COMPANY	W	3603764	01N/05W-33N01S	F49A		2,743	3,054	3,085	2,338	2,539	2,752
FONTANA UNION WATER COMPANY	W	3603765	01S/05W-05A05S	F10C		2,191	2,562	2,475	1,456	1,965	2,130
HAYES, GEO. G.	W	3601141	01S/04W-18K01S	1	1970	0	0	0	0	0	0
LA SIERRA WATER COMPANY	W	3602227	01S/04W-18G01S	15	2006	0	0	0	0	0	0
LA SIERRA WATER COMPANY	W	3602228	01S/04W-18F01S	17	2006	0	0	0	0	0	0
LEDIG, ALFRED H	D	3601383	01N/05W-18D		1959	0	0	0	0	0	0
MEEKS & DALEY WATER COMPANY	W	3601510	01S/04W-21N01S	36	2009	883	298	0	0	0	236
MEEKS & DALEY WATER COMPANY	W	3603950	01S/04W-21L05S	SPERRY WELL				0	101	0	20
MELCHIORRE, ERIK	W	3303121	02S/03W-07N03S	HOUSE		1	1	2	1	1	1
MELCHIORRE, ERIK	W	3303122	02S/03W-07N02S	AG WELL		0	1	1	1	2	1
MONTECITO MEMORIAL PARK	W	3603910	01S/04W-27Q	BARTON ROAD		175	144	134	169	169	158
PATTERSON, JOHN A	W	3600634	01S/04W-17M01S	PATTERSON	1980	0	0	0	0	0	0
PERRY AND SONS	W	0000204	01N/05W-29P		1997	0	0	0	0	0	0
RECHE CANYON MUTUAL WATER COMPANY	W	3302054	02S/04W-11A02S	#2, 20 HP ADAMS-BIG		34	30	34	49	64	42
RECHE CANYON MUTUAL WATER COMPANY	W	3302055	02S/04W-11A01S	#1, WHITTER, SMALL		17	22	19	0	2	12
RECHE CANYON MUTUAL WATER COMPANY	W	3302326	02S/04W-11A03S	#3, 7200 MILTON CT		4	28	24	23	8	17
RIALTO, CITY OF	W	3601264	01S/05W-03A01S	RIALTO #4 / DUNCAN		0	0	0	0	0	0
RIALTO, CITY OF	W	3601993	01N/05W-34B01S	RIALTO #2, HIGHLAND		0	0	0	0	0	0
RIALTO, CITY OF	W	3602253	01N/05W-27D01S	RIALTO #1, CEDAR		0	0	0	0	0	0
RIALTO, CITY OF	W	3602269	01S/05W-03N02S	RIALTO #7, TUDOR		0	0	0	0	0	0
RIALTO, CITY OF	W	3602271	01S/05W-03J01S	TUDOR	1966	0	0	0	0	0	0
RIALTO, CITY OF	W	3602558	01N/05W-34M01S	RIALTO #3, AIRPORT		621	1,739	1,786	1,868	2,151	1,633

**WESTERN - SAN BERNARDINO WATERMASTER
VERIFIED PRODUCTION DATA
CROSS INDEX BY OWNER
COLTON BASIN**

OWNER	WELL TYPE	RECRDTN NUMBER	STATE WELL NUMBER	LOCAL DESIGNATION	YEAR CLOSED	-----CALENDAR YEAR EXTRACTATIONS-----					
						2008	2009	2010	2011	2012	AVG
RIALTO, CITY OF	W	3603103	01S/05W-02G01S	RIALTO #6, ETIWANDA		0	0	0	0	0	0
RIALTO, CITY OF	W	3603576	01S/05W-02E01S	RIALTO #5		1,731	1,480	996	338	620	1,033
RIVERSIDE HIGHLAND WATER CO	W	3601525	01S/04W-28K01S	CR #4	1980	0	0	0	0	0	0
RIVERSIDE HIGHLAND WATER CO	W	3602182	01S/04W-28K02S	CR 4-A	2002	0	0	0	0	0	0
RIVERSIDE, CITY OF	W	3601480	01S/04W-21Q03S	JOHNSON 1		0	0	0	0	0	0
RIVERSIDE, CITY OF	W	3601481	01S/04W-21L01S	VAUGHN 1		0	0	0	0	0	0
RIVERSIDE, CITY OF	W	3601482	01S/04W-28C01S	MEEKS 1		0	0	0	0	0	0
RIVERSIDE, CITY OF	W	3601494	01S/04W-21P01S	JOHNSON 2	1977	0	0	0	0	0	0
RIVERSIDE, CITY OF	W	3601495	01S/04W-21Q01S	JOHNSON 3	1977	0	0	0	0	0	0
RIVERSIDE, CITY OF	D	3601496	01S/04W-21P	WARM CR	1974	0	0	0	0	0	0
RIVERSIDE, CITY OF	W	3602208	01S/04W-28D01S	MILL		1	0	0	0	0	0
RIVERSIDE, CITY OF	W	3603255	01S/04W-21L04S	JOHNSON #4		0	0	0	0	0	0
SAN GABRIEL VALLEY WATER CO	W	3603626	01S/05W-05A04S	F10B		1,974	1,730	1,946	1,936	1,910	1,899
SEQUOIA COUNTRY CLUB	W	0000203	01S/04W-07C01S	EDMUNDS	1997	0	0	0	0	0	0
SOUTHERN CALIFORNIA EDISON	W	3601008	01S/05W-12A	1 AC #58	2005	0	0	0	0	0	0
SOUTHERN CALIFORNIA EDISON	W	3601010	01S/05W-12A	2	1977	0	0	0	0	0	0
SOUTHERN CALIFORNIA EDISON	W	3602218	01S/04W-29H03S	COLTON	1981	0	0	0	0	0	0
TAYLOR, JOHN S	W	3600867	01N/05W-07P	TAYLOR 1	1974	0	0	0	0	0	0
TAYLOR, JOHN S	D	3600868	01N/05W-07P		1974	0	0	0	0	0	0
VILLELLI ENTERPRISES	W	0000201	01S/04W-28G	4	1997	0	0	0	0	0	0
VILLELLI ENTERPRISES	W	0000202	01S/04W-28G	#5 DOMESTIC	1997	0	0	0	0	0	0
VILLELLI ENTERPRISES	W	3601548	01S/04W-28G01S	1	1981	0	0	0	0	0	0
VILLELLI ENTERPRISES	W	3601550	01S/04W-28A05S	3	1981	0	0	0	0	0	0
WEST VALLEY WATER DIST	W	3600309	01S/05W-02C01S	#10 BASELINE WILLOW	1982	0	0	0	0	0	0
WEST VALLEY WATER DIST	W	3600311	01S/05W-02K01S	#11 VICTORIA/WILLOW		0	0	1,562	1,296	234	618
WEST VALLEY WATER DIST	W	3600995	01S/05W-12N01S	#17 ACACIA/MERREL		0	0	0	0	0	0
WEST VALLEY WATER DIST	W	3601001	01S/05W-12L01S	#16 / BOYD		147	37	450	840	915	478
WEST VALLEY WATER DIST	W	3601689	01N/05W-17K01S	#21 / FONTANA RNCH 1	1976	0	0	0	0	0	0
WEST VALLEY WATER DIST	W	3601690	01N/05W-28J01S	#22 / FONTANA RNCH 2	2002	0	0	0	0	0	0
WEST VALLEY WATER DIST	W	3601691	01N/05W-17G01S	#23 / FONTANA RNCH 3	1992	0	0	0	0	0	0
WEST VALLEY WATER DIST	W	3601931	01N/05W-17K02S	#24 / FONTANA RNCH 4		494	523	606	661	414	540
WEST VALLEY WATER DIST	W	3603465	01S/05W-03A02S	#33 SHOP		1,315	1,715	1,408	1,293	1,325	1,411
WEST VALLEY WATER DIST	W	3603770	01N/05W-27B01S	#22A LINDEN VINEYARD		0	0	0	0	0	0
WEST VALLEY WATER DIST	W	3603771	01N/05W-17G02S	#23A		0	0	0	0	0	0
WEST VALLEY WATER DIST	W	3603946	01N/06W-24C01S	#54		795	1,466	1,310	793	1,205	1,114
TOTALS FOR 72 WELLS						20,658	23,536	24,455	20,573	20,149	21,874

COLTON BASIN AREA
CROSS INDEX BY STATE WELL NUMBER

**WESTERN - SAN BERNARDINO WATERMASTER
VERIFIED PRODUCTION DATA
CROSS INDEX BY STATE WELL NUMBER
COLTON BASIN**

STATE WELL NUMBER	RECRDTN NUMBER	OWNER	WELL TYPE	LOCAL DESIGNATION	YEAR CLOSED	-----CALENDAR YEAR EXTRACTIONS-----					
						2008	2009	2010	2011	2012	AVG
01N/05W-07P	3600867	TAYLOR, JOHN S	W	TAYLOR 1	1974	0	0	0	0	0	0
01N/05W-07P	3600868	TAYLOR, JOHN S	D		1974	0	0	0	0	0	0
01N/05W-17G01S	3601691	WEST VALLEY WATER DIST	W	#23 / FONTANA RNCH 3	1992	0	0	0	0	0	0
01N/05W-17G02S	3603771	WEST VALLEY WATER DIST	W	#23A		0	0	0	0	0	0
01N/05W-17K01S	3601689	WEST VALLEY WATER DIST	W	#21 / FONTANA RNCH 1	1976	0	0	0	0	0	0
01N/05W-17K02S	3601931	WEST VALLEY WATER DIST	W	#24 / FONTANA RNCH 4		494	523	606	661	414	540
01N/05W-18D	3601383	LEDIG, ALFRED H	D		1959	0	0	0	0	0	0
01N/05W-27B01S	3603770	WEST VALLEY WATER DIST	W	#22A LINDEN VINEYARD		0	0	0	0	0	0
01N/05W-27D01S	3602253	RIALTO, CITY OF	W	RIALTO #1, CEDAR		0	0	0	0	0	0
01N/05W-28J01S	3601690	WEST VALLEY WATER DIST	W	#22 / FONTANA RNCH 2	2002	0	0	0	0	0	0
01N/05W-29P	0000204	PERRY AND SONS	W		1997	0	0	0	0	0	0
01N/05W-29R15S	3603060	FONTANA UNION WATER COMPANY	W	F13A (OLD FU #37)		768	1,828	1,477	1,629	1,590	1,458
01N/05W-30A	3602129	FONTANA UNION WATER COMPANY	W	36	1980	0	0	0	0	0	0
01N/05W-32A02S	3603739	FONTANA UNION WATER COMPANY	W	F13B		1,617	1,990	1,851	1,411	1,124	1,599
01N/05W-33N01S	3603764	FONTANA UNION WATER COMPANY	W	F49A		2,743	3,054	3,085	2,338	2,539	2,752
01N/05W-34B01S	3601993	RIALTO, CITY OF	W	RIALTO #2, HIGHLAND		0	0	0	0	0	0
01N/05W-34M01S	3602558	RIALTO, CITY OF	W	RIALTO #3, AIRPORT		621	1,739	1,786	1,868	2,151	1,633
01N/06W-24C01S	3603946	WEST VALLEY WATER DIST	W	#54		795	1,466	1,310	793	1,205	1,114
01N/06W-25A01S	3603726	FONTANA UNION WATER COMPANY	W	F15A		1,184	1,608	1,369	1,007	1,053	1,244
01S/04W-07C01S	0000203	SEQUOIA COUNTRY CLUB	W	EDMUNDS	1997	0	0	0	0	0	0
01S/04W-08Q04S	3603916	COLTON, CITY OF	W	#29		0	0	0	0	0	0
01S/04W-17M01S	3600634	PATTERSON, JOHN A	W	PATTERSON	1980	0	0	0	0	0	0
01S/04W-18B	3601255	COLTON, CITY OF	W	9	1982	0	0	0	0	0	0
01S/04W-18F01S	3601261	COLTON, CITY OF	W	17		1,414	1,053	1,304	1,321	1,152	1,249
01S/04W-18F01S	3602228	LA SIERRA WATER COMPANY	W	17	2006	0	0	0	0	0	0
01S/04W-18G01S	3601259	COLTON, CITY OF	W	15		537	539	650	467	607	560
01S/04W-18G01S	3602227	LA SIERRA WATER COMPANY	W	15	2006	0	0	0	0	0	0
01S/04W-18K01S	3601141	HAYES, GEO. G.	W	1	1970	0	0	0	0	0	0
01S/04W-21K01S	3603367	COLTON, CITY OF	W	#23		1,684	1,683	1,543	965	764	1,328
01S/04W-21L01S	3601481	RIVERSIDE, CITY OF	W	VAUGHN 1		0	0	0	0	0	0
01S/04W-21L04S	3603255	RIVERSIDE, CITY OF	W	JOHNSON #4		0	0	0	0	0	0
01S/04W-21L05S	3603950	MEEKS & DALEY WATER COMPANY	W	SPERRY WELL				0	101	0	20
01S/04W-21N01S	3601510	MEEKS & DALEY WATER COMPANY	W	36	2009	883	298	0	0	0	236
01S/04W-21P	3601496	RIVERSIDE, CITY OF	D	WARM CR	1974	0	0	0	0	0	0
01S/04W-21P01S	3601494	RIVERSIDE, CITY OF	W	JOHNSON 2	1977	0	0	0	0	0	0
01S/04W-21Q01S	3601495	RIVERSIDE, CITY OF	W	JOHNSON 3	1977	0	0	0	0	0	0
01S/04W-21Q03S	3601480	RIVERSIDE, CITY OF	W	JOHNSON 1		0	0	0	0	0	0

**WESTERN - SAN BERNARDINO WATERMASTER
VERIFIED PRODUCTION DATA
CROSS INDEX BY STATE WELL NUMBER
COLTON BASIN**

STATE WELL NUMBER	RECRDTN NUMBER	OWNER	WELL TYPE	LOCAL DESIGNATION	YEAR CLOSED	-----CALENDAR YEAR EXTRACTIONS-----					
						2008	2009	2010	2011	2012	AVG
01S/04W-27L01S	3602255	COLTON, CITY OF	W	KATZ/HOLLOW		0	0	0	0	0	0
01S/04W-27L03S	3602881	COLTON, CITY OF	W	22		328	5	423	610	335	340
01S/04W-27Q	3603910	MONTECITO MEMORIAL PARK	W	BARTON ROAD		175	144	134	169	169	158
01S/04W-28A05S	3601550	VILLELLI ENTERPRISES	W	3	1981	0	0	0	0	0	0
01S/04W-28C01S	3601482	RIVERSIDE, CITY OF	W	MEEKS 1		0	0	0	0	0	0
01S/04W-28D01S	3602208	RIVERSIDE, CITY OF	W	MILL		1	0	0	0	0	0
01S/04W-28G	0000201	VILLELLI ENTERPRISES	W	4	1997	0	0	0	0	0	0
01S/04W-28G	0000202	VILLELLI ENTERPRISES	W	#5 DOMESTIC	1997	0	0	0	0	0	0
01S/04W-28G01S	3601548	VILLELLI ENTERPRISES	W	1	1981	0	0	0	0	0	0
01S/04W-28K01S	3601525	RIVERSIDE HIGHLAND WATER CO	W	CR #4	1980	0	0	0	0	0	0
01S/04W-28K02S	3602182	RIVERSIDE HIGHLAND WATER CO	W	CR 4-A	2002	0	0	0	0	0	0
01S/04W-29H03S	3602218	SOUTHERN CALIFORNIA EDISON	W	COLTON	1981	0	0	0	0	0	0
01S/04W-34H	3602356	COLTON, CITY OF	W	5731- JAMES SULLIVAN		0	0	0	0	0	0
01S/05W-02C01S	3600309	WEST VALLEY WATER DIST	W	#10 BASELINE WILLOW	1982	0	0	0	0	0	0
01S/05W-02E01S	3603576	RIALTO, CITY OF	W	RIALTO #5		1,731	1,480	996	338	620	1,033
01S/05W-02G01S	3603103	RIALTO, CITY OF	W	RIALTO #6, ETIWANDA		0	0	0	0	0	0
01S/05W-02K01S	3600311	WEST VALLEY WATER DIST	W	#11 VICTORIA/WILLOW		0	0	1,562	1,296	234	618
01S/05W-03A01S	3601264	RIALTO, CITY OF	W	RIALTO #4 / DUNCAN		0	0	0	0	0	0
01S/05W-03A02S	3603465	WEST VALLEY WATER DIST	W	#33 SHOP		1,315	1,715	1,408	1,293	1,325	1,411
01S/05W-03J01S	3602271	RIALTO, CITY OF	W	TUDOR	1966	0	0	0	0	0	0
01S/05W-03N02S	3602269	RIALTO, CITY OF	W	RIALTO #7, TUDOR		0	0	0	0	0	0
01S/05W-04D01S	3600589	FONTANA UNION WATER COMPANY	W	35	1989	0	0	0	0	0	0
01S/05W-05A02S	3600578	FONTANA UNION WATER COMPANY	W	23	1980	0	0	0	0	0	0
01S/05W-05A03S	3600577	FONTANA UNION WATER COMPANY	W	22	2002	0	0	0	0	0	0
01S/05W-05A04S	3603626	SAN GABRIEL VALLEY WATER CO	W	F10B		1,974	1,730	1,946	1,936	1,910	1,899
01S/05W-05A05S	3603765	FONTANA UNION WATER COMPANY	W	F10C		2,191	2,562	2,475	1,456	1,965	2,130
01S/05W-12A	3601008	SOUTHERN CALIFORNIA EDISON	W	1 AC #58	2005	0	0	0	0	0	0
01S/05W-12A	3601010	SOUTHERN CALIFORNIA EDISON	W	2	1977	0	0	0	0	0	0
01S/05W-12L01S	3601001	WEST VALLEY WATER DIST	W	#16 / BOYD		147	37	450	840	915	478
01S/05W-12N01S	3600995	WEST VALLEY WATER DIST	W	#17 ACACIA/MERREL		0	0	0	0	0	0
02S/03W-07N02S	3303122	MELCHIORRE, ERIK	W	AG WELL		0	1	1	1	2	1
02S/03W-07N03S	3303121	MELCHIORRE, ERIK	W	HOUSE		1	1	2	1	1	1
02S/04W-11A01S	3302055	RECHE CANYON MUTUAL WATER COMPANY	W	#1, WHITTER, SMALL		17	22	19	0	2	12
02S/04W-11A02S	3302054	RECHE CANYON MUTUAL WATER COMPANY	W	#2, 20 HP ADAMS-BIG		34	30	34	49	64	42
02S/04W-11A03S	3302326	RECHE CANYON MUTUAL WATER COMPANY	W	#3, 7200 MILTON CT		4	28	24	23	8	17
TOTALS FOR 72 WELLS						20,658	23,536	24,455	20,573	20,149	21,874

COLTON BASIN AREA
CROSS INDEX BY RECORDATION NUMBER

**WESTERN - SAN BERNARDINO WATERMASTER
VERIFIED PRODUCTION DATA
CROSS INDEX BY RECORDATION NUMBER
COLTON BASIN**

RECRDTN NUMBER	STATE WELL NUMBER	OWNER	WELL TYPE	LOCAL DESIGNATION	YEAR CLOSED	-----CALENDAR YEAR EXTRACTIONS-----					
						2008	2009	2010	2011	2012	AVG
0000201	01S/04W-28G	VILLELLI ENTERPRISES	W	4	1997	0	0	0	0	0	0
0000202	01S/04W-28G	VILLELLI ENTERPRISES	W	#5 DOMESTIC	1997	0	0	0	0	0	0
0000203	01S/04W-07C01S	SEQUOIA COUNTRY CLUB	W	EDMUNDS	1997	0	0	0	0	0	0
0000204	01N/05W-29P	PERRY AND SONS	W		1997	0	0	0	0	0	0
3302054	02S/04W-11A02S	RECHE CANYON MUTUAL WATER COMPANY	W	#2, 20 HP ADAMS-BIG		34	30	34	49	64	42
3302055	02S/04W-11A01S	RECHE CANYON MUTUAL WATER COMPANY	W	#1, WHITTER, SMALL		17	22	19	0	2	12
3302326	02S/04W-11A03S	RECHE CANYON MUTUAL WATER COMPANY	W	#3, 7200 MILTON CT		4	28	24	23	8	17
3303121	02S/03W-07N03S	MELCHIORRE, ERIK	W	HOUSE		1	1	2	1	1	1
3303122	02S/03W-07N02S	MELCHIORRE, ERIK	W	AG WELL		0	1	1	1	2	1
3600309	01S/05W-02C01S	WEST VALLEY WATER DIST	W	#10 BASELINE WILLOW	1982	0	0	0	0	0	0
3600311	01S/05W-02K01S	WEST VALLEY WATER DIST	W	#11 VICTORIA/WILLOW		0	0	1,562	1,296	234	618
3600577	01S/05W-05A03S	FONTANA UNION WATER COMPANY	W	22	2002	0	0	0	0	0	0
3600578	01S/05W-05A02S	FONTANA UNION WATER COMPANY	W	23	1980	0	0	0	0	0	0
3600589	01S/05W-04D01S	FONTANA UNION WATER COMPANY	W	35	1989	0	0	0	0	0	0
3600634	01S/04W-17M01S	PATTERSON, JOHN A	W	PATTERSON	1980	0	0	0	0	0	0
3600867	01N/05W-07P	TAYLOR, JOHN S	W	TAYLOR 1	1974	0	0	0	0	0	0
3600868	01N/05W-07P	TAYLOR, JOHN S	D		1974	0	0	0	0	0	0
3600995	01S/05W-12N01S	WEST VALLEY WATER DIST	W	#17 ACACIA/MERREL		0	0	0	0	0	0
3601001	01S/05W-12L01S	WEST VALLEY WATER DIST	W	#16 / BOYD		147	37	450	840	915	478
3601008	01S/05W-12A	SOUTHERN CALIFORNIA EDISON	W	1 AC #58	2005	0	0	0	0	0	0
3601010	01S/05W-12A	SOUTHERN CALIFORNIA EDISON	W	2	1977	0	0	0	0	0	0
3601141	01S/04W-18K01S	HAYES, GEO. G.	W	1	1970	0	0	0	0	0	0
3601255	01S/04W-18B	COLTON, CITY OF	W	9	1982	0	0	0	0	0	0
3601259	01S/04W-18G01S	COLTON, CITY OF	W	15		537	539	650	467	607	560
3601261	01S/04W-18F01S	COLTON, CITY OF	W	17		1,414	1,053	1,304	1,321	1,152	1,249
3601264	01S/05W-03A01S	RIALTO, CITY OF	W	RIALTO #4 / DUNCAN		0	0	0	0	0	0
3601383	01N/05W-18D	LEDIG, ALFRED H	D		1959	0	0	0	0	0	0
3601480	01S/04W-21Q03S	RIVERSIDE, CITY OF	W	JOHNSON 1		0	0	0	0	0	0
3601481	01S/04W-21L01S	RIVERSIDE, CITY OF	W	VAUGHN 1		0	0	0	0	0	0
3601482	01S/04W-28C01S	RIVERSIDE, CITY OF	W	MEEKS 1		0	0	0	0	0	0
3601494	01S/04W-21P01S	RIVERSIDE, CITY OF	W	JOHNSON 2	1977	0	0	0	0	0	0
3601495	01S/04W-21Q01S	RIVERSIDE, CITY OF	W	JOHNSON 3	1977	0	0	0	0	0	0
3601496	01S/04W-21P	RIVERSIDE, CITY OF	D	WARM CR	1974	0	0	0	0	0	0
3601510	01S/04W-21N01S	MEEKS & DALEY WATER COMPANY	W	36	2009	883	298	0	0	0	236
3601525	01S/04W-28K01S	RIVERSIDE HIGHLAND WATER CO	W	CR #4	1980	0	0	0	0	0	0

**WESTERN - SAN BERNARDINO WATERMASTER
VERIFIED PRODUCTION DATA
CROSS INDEX BY RECORDATION NUMBER
COLTON BASIN**

RECRDTN NUMBER	STATE WELL NUMBER	WELL OWNER	WELL TYPE	LOCAL DESIGNATION	YEAR CLOSED	-----CALENDAR YEAR EXTRACTIONS-----					
						2008	2009	2010	2011	2012	AVG
3601548	01S/04W-28G01S	VILLELLI ENTERPRISES	W	1	1981	0	0	0	0	0	0
3601550	01S/04W-28A05S	VILLELLI ENTERPRISES	W	3	1981	0	0	0	0	0	0
3601689	01N/05W-17K01S	WEST VALLEY WATER DIST	W	#21 / FONTANA RNCH 1	1976	0	0	0	0	0	0
3601690	01N/05W-28J01S	WEST VALLEY WATER DIST	W	#22 / FONTANA RNCH 2	2002	0	0	0	0	0	0
3601691	01N/05W-17G01S	WEST VALLEY WATER DIST	W	#23 / FONTANA RNCH 3	1992	0	0	0	0	0	0
3601931	01N/05W-17K02S	WEST VALLEY WATER DIST	W	#24 / FONTANA RNCH 4		494	523	606	661	414	540
3601993	01N/05W-34B01S	RIALTO, CITY OF	W	RIALTO #2, HIGHLAND		0	0	0	0	0	0
3602129	01N/05W-30A	FONTANA UNION WATER COMPANY	W	36	1980	0	0	0	0	0	0
3602182	01S/04W-28K02S	RIVERSIDE HIGHLAND WATER CO	W	CR 4-A	2002	0	0	0	0	0	0
3602208	01S/04W-28D01S	RIVERSIDE, CITY OF	W	MILL		1	0	0	0	0	0
3602218	01S/04W-29H03S	SOUTHERN CALIFORNIA EDISON	W	COLTON	1981	0	0	0	0	0	0
3602227	01S/04W-18G01S	LA SIERRA WATER COMPANY	W	15	2006	0	0	0	0	0	0
3602228	01S/04W-18F01S	LA SIERRA WATER COMPANY	W	17	2006	0	0	0	0	0	0
3602253	01N/05W-27D01S	RIALTO, CITY OF	W	RIALTO #1, CEDAR		0	0	0	0	0	0
3602255	01S/04W-27L01S	COLTON, CITY OF	W	KATZ/HOLLOW		0	0	0	0	0	0
3602269	01S/05W-03N02S	RIALTO, CITY OF	W	RIALTO #7, TUDOR		0	0	0	0	0	0
3602271	01S/05W-03J01S	RIALTO, CITY OF	W	TUDOR	1966	0	0	0	0	0	0
3602356	01S/04W-34H	COLTON, CITY OF	W	5731- JAMES SULLIVAN		0	0	0	0	0	0
3602558	01N/05W-34M01S	RIALTO, CITY OF	W	RIALTO #3, AIRPORT		621	1,739	1,786	1,868	2,151	1,633
3602881	01S/04W-27L03S	COLTON, CITY OF	W	22		328	5	423	610	335	340
3603060	01N/05W-29R15S	FONTANA UNION WATER COMPANY	W	F13A (OLD FU #37)		768	1,828	1,477	1,629	1,590	1,458
3603103	01S/05W-02G01S	RIALTO, CITY OF	W	RIALTO #6, ETIWANDA		0	0	0	0	0	0
3603255	01S/04W-21L04S	RIVERSIDE, CITY OF	W	JOHNSON #4		0	0	0	0	0	0
3603367	01S/04W-21K01S	COLTON, CITY OF	W	#23		1,684	1,683	1,543	965	764	1,328
3603465	01S/05W-03A02S	WEST VALLEY WATER DIST	W	#33 SHOP		1,315	1,715	1,408	1,293	1,325	1,411
3603576	01S/05W-02E01S	RIALTO, CITY OF	W	RIALTO #5		1,731	1,480	996	338	620	1,033
3603626	01S/05W-05A04S	SAN GABRIEL VALLEY WATER CO	W	F10B		1,974	1,730	1,946	1,936	1,910	1,899
3603726	01N/06W-25A01S	FONTANA UNION WATER COMPANY	W	F15A		1,184	1,608	1,369	1,007	1,053	1,244
3603739	01N/05W-32A02S	FONTANA UNION WATER COMPANY	W	F13B		1,617	1,990	1,851	1,411	1,124	1,599
3603764	01N/05W-33N01S	FONTANA UNION WATER COMPANY	W	F49A		2,743	3,054	3,085	2,338	2,539	2,752
3603765	01S/05W-05A05S	FONTANA UNION WATER COMPANY	W	F10C		2,191	2,562	2,475	1,456	1,965	2,130
3603770	01N/05W-27B01S	WEST VALLEY WATER DIST	W	#22A LINDEN VINEYARD		0	0	0	0	0	0
3603771	01N/05W-17G02S	WEST VALLEY WATER DIST	W	#23A		0	0	0	0	0	0
3603910	01S/04W-27Q	MONTECITO MEMORIAL PARK	W	BARTON ROAD		175	144	134	169	169	158
3603916	01S/04W-08Q04S	COLTON, CITY OF	W	#29		0	0	0	0	0	0

**WESTERN - SAN BERNARDINO WATERMASTER
 VERIFIED PRODUCTION DATA
 CROSS INDEX BY RECORDATION NUMBER
 COLTON BASIN**

RECRDTN NUMBER	STATE WELL NUMBER	OWNER	WELL TYPE	LOCAL DESIGNATION	YEAR CLOSED	-----CALENDAR YEAR EXTRACTIONS-----					
						2008	2009	2010	2011	2012	AVG
3603946	01N/06W-24C01S	WEST VALLEY WATER DIST	W	#54		795	1,466	1,310	793	1,205	1,114
3603950	01S/04W-21L05S	MEEKS & DALEY WATER COMPANY	W	SPERRY WELL				0	101	0	20
TOTALS FOR 72 WELLS						20,658	23,536	24,455	20,573	20,149	21,874

TABLE NO. 1
VERIFIED EXTRACTIONS BY OWNERS
WHICH HAVE RECORDATION FILINGS WITH
THE STATE WATER RESOURCES CONTROL BOARD

WESTERN - SAN BERNARDINO WATERMASTER
TABLE 1
VERIFIED EXTRACTIONS - FILED
COLTON BASIN

RECRDTN NUMBER	STATE WELL NUMBER	WELL TYPE	LOCAL DESIGNATION	FC	-----BASE YEARS-----						-----CALENDAR YEAR EXTRACTIONS-----					
					1959	1960	1961	1962	1963	AVG	2008	2009	2010	2011	2012	AVG
COLTON, CITY OF																
3603916	01S/04W-08Q04S	W	#29	<input type="checkbox"/>							0	0	0	0	0	0
3601255	01S/04W-18B	W	9	<input checked="" type="checkbox"/>	101	101	106	135	103	109	0	0	0	0	0	0
3601261	01S/04W-18F01S	W	17	<input type="checkbox"/>	761	880	752	394	474	652	1,414	1,053	1,304	1,321	1,152	1,249
3601259	01S/04W-18G01S	W	15	<input type="checkbox"/>	1,064	781	787	377	455	693	537	539	650	467	607	560
3603367	01S/04W-21K01S	W	#23	<input type="checkbox"/>						0	1,684	1,683	1,543	965	764	1,328
3602255	01S/04W-27L01S	W	KATZ/HOLLOW	<input type="checkbox"/>	283	283	283	283	0	226	0	0	0	0	0	0
3602881	01S/04W-27L03S	W	22	<input type="checkbox"/>						0	328	5	423	610	335	340
3602356	01S/04W-34H	W	5731- JAMES SULLIVA	<input type="checkbox"/>	22	24	12	13	14	17	0	0	0	0	0	0
TOTALS FOR COLTON, CITY OF					2,231	2,069	1,940	1,202	1,046	1,698	3,963	3,280	3,920	3,363	2,858	3,477
FONTANA UNION WATER COMPANY																
3603060	01N/05W-29R15S	W	F13A (OLD FU #37)	<input type="checkbox"/>						0	768	1,828	1,477	1,629	1,590	1,458
3602129	01N/05W-30A	W	36	<input checked="" type="checkbox"/>	31	31	31	31	31	31	0	0	0	0	0	0
3603739	01N/05W-32A02S	W	F13B	<input type="checkbox"/>						0	1,617	1,990	1,851	1,411	1,124	1,599
3603764	01N/05W-33N01S	W	F49A	<input type="checkbox"/>						0	2,743	3,054	3,085	2,338	2,539	2,752
3603726	01N/06W-25A01S	W	F15A	<input type="checkbox"/>						0	1,184	1,608	1,369	1,007	1,053	1,244
3600589	01S/05W-04D01S	W	35	<input checked="" type="checkbox"/>	437	621	227	407	449	428	0	0	0	0	0	0
3600578	01S/05W-05A02S	W	23	<input checked="" type="checkbox"/>	0	0	429	0	0	86	0	0	0	0	0	0
3600577	01S/05W-05A03S	W	22	<input checked="" type="checkbox"/>	0	132	546	0	400	216	0	0	0	0	0	0
3603765	01S/05W-05A05S	W	F10C	<input type="checkbox"/>						0	2,191	2,562	2,475	1,456	1,965	2,130
TOTALS FOR FONTANA UNION WATER COMPANY					468	784	1,233	438	880	761	8,503	11,042	10,257	7,841	8,271	9,183
HAYES, GEO. G.																
3601141	01S/04W-18K01S	W	1	<input checked="" type="checkbox"/>	0	0	0	0	0	0	0	0	0	0	0	0
TOTALS FOR HAYES, GEO. G.					0	0	0	0	0	0	0	0	0	0	0	0
LA SIERRA WATER COMPANY																
3602228	01S/04W-18F01S	W	17	<input checked="" type="checkbox"/>						0	0	0	0	0	0	0
3602227	01S/04W-18G01S	W	15	<input checked="" type="checkbox"/>						0	0	0	0	0	0	0
TOTALS FOR LA SIERRA WATER COMPANY										0	0	0	0	0	0	0

**WESTERN - SAN BERNARDINO WATERMASTER
TABLE 1
VERIFIED EXTRACTIONS - FILED
COLTON BASIN**

RECRDTN NUMBER	STATE WELL NUMBER	WELL TYPE	LOCAL DESIGNATION	FC	-----BASE YEARS-----						-----CALENDAR YEAR EXTRACTIONS-----						
					1959	1960	1961	1962	1963	AVG	2008	2009	2010	2011	2012	AVG	
LEDIG, ALFRED H																	
3601383	01N/05W-18D	D		<input checked="" type="checkbox"/>	0	0	0	0	0	0	0	0	0	0	0	0	
TOTALS FOR LEDIG, ALFRED H					0	0	0	0	0	0	0	0	0	0	0	0	
MEEKS & DALEY WATER COMPANY																	
3603950	01S/04W-21L05S	W	SPERRY WELL	<input type="checkbox"/>							0			0	101	0	20
3601510	01S/04W-21N01S	W	36	<input checked="" type="checkbox"/>	2,168	23	465	1,185	339	836	883	298	0	0	0	0	236
TOTALS FOR MEEKS & DALEY WATER COMPANY					2,168	23	465	1,185	339	836	883	298	0	101	0	256	
MELCHIORRE, ERIK																	
3303122	02S/03W-07N02S	W	AG WELL	<input type="checkbox"/>						0	0	1	1	1	2	1	
3303121	02S/03W-07N03S	W	HOUSE	<input type="checkbox"/>						0	1	1	2	1	1	1	
TOTALS FOR MELCHIORRE, ERIK										0	1	2	3	2	3	2	
MONTECITO MEMORIAL PARK																	
3603910	01S/04W-27Q	W	BARTON ROAD	<input type="checkbox"/>						0	175	144	134	169	169	158	
TOTALS FOR MONTECITO MEMORIAL PARK										0	175	144	134	169	169	158	
PATTERSON, JOHN A																	
3600634	01S/04W-17M01S	W	PATTERSON	<input checked="" type="checkbox"/>	137	0	0	0	0	27	0	0	0	0	0	0	
TOTALS FOR PATTERSON, JOHN A					137	0	0	0	0	27	0	0	0	0	0	0	
RECHE CANYON MUTUAL WATER COMPANY																	
3302055	02S/04W-11A01S	W	#1, WHITTER, SMALL	<input type="checkbox"/>						0	17	22	19	0	2	12	
3302054	02S/04W-11A02S	W	#2, 20 HP ADAMS-BIG	<input type="checkbox"/>						0	34	30	34	49	64	42	
3302326	02S/04W-11A03S	W	#3, 7200 MILTON CT	<input type="checkbox"/>						0	4	28	24	23	8	17	
TOTALS FOR RECHE CANYON MUTUAL WATER COMPANY										0	55	80	77	72	74	72	
RIALTO, CITY OF																	
3602253	01N/05W-27D01S	W	RIALTO #1, CEDAR	<input type="checkbox"/>						0	0	0	0	0	0	0	
3601993	01N/05W-34B01S	W	RIALTO #2, HIGHLAN	<input type="checkbox"/>			723	600	265	0	0	0	0	0	0	0	
3602558	01N/05W-34M01S	W	RIALTO #3, AIRPORT	<input type="checkbox"/>						0	621	1,739	1,786	1,868	2,151	1,633	
3603576	01S/05W-02E01S	W	RIALTO #5	<input type="checkbox"/>						0	1,731	1,480	996	338	620	1,033	
3603103	01S/05W-02G01S	W	RIALTO #6, ETIWAND	<input type="checkbox"/>						0	0	0	0	0	0	0	

**WESTERN - SAN BERNARDINO WATERMASTER
TABLE 1
VERIFIED EXTRACTIIONS - FILED
COLTON BASIN**

RECRDTN NUMBER	STATE WELL NUMBER	WELL TYPE	LOCAL DESIGNATION	FC	-----BASE YEARS-----						-----CALENDAR YEAR EXTRACTIIONS-----					
					1959	1960	1961	1962	1963	AVG	2008	2009	2010	2011	2012	AVG
3601264	01S/05W-03A01S	W	RIALTO #4 / DUNCAN	<input type="checkbox"/>	987	808	1,372	754	994	983	0	0	0	0	0	0
3602271	01S/05W-03J01S	W	TUDOR	<input checked="" type="checkbox"/>	160	160	160	160	160	160	0	0	0	0	0	0
3602269	01S/05W-03N02S	W	RIALTO #7, TUDOR	<input type="checkbox"/>		275	342	236	385	248	0	0	0	0	0	0
TOTALS FOR RIALTO, CITY OF					1,147	1,243	1,874	1,873	2,139	1,655	2,352	3,219	2,782	2,206	2,771	2,666
RIVERSIDE HIGHLAND WATER CO																
3601525	01S/04W-28K01S	W	CR #4	<input checked="" type="checkbox"/>	211	126	357	280	163	227	0	0	0	0	0	0
3602182	01S/04W-28K02S	W	CR 4-A	<input checked="" type="checkbox"/>						0	0	0	0	0	0	0
TOTALS FOR RIVERSIDE HIGHLAND WATER CO					211	126	357	280	163	227	0	0	0	0	0	0
RIVERSIDE, CITY OF																
3601481	01S/04W-21L01S	W	VAUGHN 1	<input type="checkbox"/>	39	135	1,378	498	593	529	0	0	0	0	0	0
3603255	01S/04W-21L04S	W	JOHNSON #4	<input type="checkbox"/>						0	0	0	0	0	0	0
3601496	01S/04W-21P	D	WARM CR	<input checked="" type="checkbox"/>	0	0	0	0	0	0	0	0	0	0	0	0
3601494	01S/04W-21P01S	W	JOHNSON 2	<input checked="" type="checkbox"/>	0	0	0	0	0	0	0	0	0	0	0	0
3601495	01S/04W-21Q01S	W	JOHNSON 3	<input checked="" type="checkbox"/>	0	0	0	0	0	0	0	0	0	0	0	0
3601480	01S/04W-21Q03S	W	JOHNSON 1	<input type="checkbox"/>	2,183	1,569	1,569	963	789	1,415	0	0	0	0	0	0
3601482	01S/04W-28C01S	W	MEEKS 1	<input type="checkbox"/>	649	461	539	374	425	490	0	0	0	0	0	0
3602208	01S/04W-28D01S	W	MILL	<input type="checkbox"/>						0	1	0	0	0	0	0
TOTALS FOR RIVERSIDE, CITY OF					2,871	2,165	3,486	1,835	1,807	2,433	1	0	0	0	0	0
SAN GABRIEL VALLEY WATER CO																
3603626	01S/05W-05A04S	W	F10B	<input type="checkbox"/>						0	1,974	1,730	1,946	1,936	1,910	1,899
TOTALS FOR SAN GABRIEL VALLEY WATER CO										0	1,974	1,730	1,946	1,936	1,910	1,899
SOUTHERN CALIFORNIA EDISON																
3602218	01S/04W-29H03S	W	COLTON	<input checked="" type="checkbox"/>	8	8	7	8	8	8	0	0	0	0	0	0
3601008	01S/05W-12A	W	1 AC #58	<input checked="" type="checkbox"/>	199	200	215	200	200	203	0	0	0	0	0	0
3601010	01S/05W-12A	W	2	<input checked="" type="checkbox"/>	0	0	0	0	0	0	0	0	0	0	0	0
TOTALS FOR SOUTHERN CALIFORNIA EDISON					207	208	222	208	208	211	0	0	0	0	0	0
TAYLOR, JOHN S																
3600867	01N/05W-07P	W	TAYLOR 1	<input checked="" type="checkbox"/>	0	0	0	0	0	0	0	0	0	0	0	0

WESTERN - SAN BERNARDINO WATERMASTER
TABLE 1
VERIFIED EXTRACTIONS - FILED
COLTON BASIN

RECRDTN NUMBER	STATE WELL NUMBER	WELL TYPE	LOCAL DESIGNATION	FC	-----BASE YEARS-----						-----CALENDAR YEAR EXTRACTIONS-----					
					1959	1960	1961	1962	1963	AVG	2008	2009	2010	2011	2012	AVG
3600868	01N/05W-07P	D		<input checked="" type="checkbox"/>	0	0	0	0	0	0	0	0	0	0	0	0
TOTALS FOR TAYLOR, JOHN S					0	0	0	0	0	0	0	0	0	0	0	0
VILLELLI ENTERPRISES																
3601550	01S/04W-28A05S	W	3	<input checked="" type="checkbox"/>	193	147	172	75	2	118	0	0	0	0	0	0
3601548	01S/04W-28G01S	W	1	<input checked="" type="checkbox"/>	246	171	209	105	41	154	0	0	0	0	0	0
TOTALS FOR VILLELLI ENTERPRISES					439	318	381	180	43	272	0	0	0	0	0	0
WEST VALLEY WATER DIST																
3601691	01N/05W-17G01S	W	#23 / FONTANA RNCH	<input checked="" type="checkbox"/>	116	43	15	54	15	49	0	0	0	0	0	0
3603771	01N/05W-17G02S	W	#23A	<input type="checkbox"/>						0	0	0	0	0	0	0
3601689	01N/05W-17K01S	W	#21 / FONTANA RNCH	<input checked="" type="checkbox"/>	3	0	0	1	0	1	0	0	0	0	0	0
3601931	01N/05W-17K02S	W	#24 / FONTANA RNCH	<input type="checkbox"/>		84	115	95	132	85	494	523	606	661	414	540
3603770	01N/05W-27B01S	W	#22A LINDEN VINEYA	<input type="checkbox"/>						0	0	0	0	0	0	0
3601690	01N/05W-28J01S	W	#22 / FONTANA RNCH	<input checked="" type="checkbox"/>	0	0	0	0	0	0	0	0	0	0	0	0
3603946	01N/06W-24C01S	W	#54	<input type="checkbox"/>						0	795	1,466	1,310	793	1,205	1,114
3600309	01S/05W-02C01S	W	#10 BASELINE WILLO	<input checked="" type="checkbox"/>	1,222	1,032	837	763	825	936	0	0	0	0	0	0
3600311	01S/05W-02K01S	W	#11 VICTORIA/WILLO	<input type="checkbox"/>	0	1,096	1,123	563	1,042	765	0	0	1,562	1,296	234	618
3603465	01S/05W-03A02S	W	#33 SHOP	<input type="checkbox"/>						0	1,315	1,715	1,408	1,293	1,325	1,411
3601001	01S/05W-12L01S	W	#16 / BOYD	<input type="checkbox"/>	1,418	1,145	1,453	1,089	627	1,146	147	37	450	840	915	478
3600995	01S/05W-12N01S	W	#17 ACACIA/MERREL	<input type="checkbox"/>	476	795	630	475	128	501	0	0	0	0	0	0
TOTALS FOR WEST VALLEY WATER DIST					3,235	4,195	4,173	3,040	2,769	3,482	2,751	3,741	5,336	4,883	4,093	4,161
TOTALS FOR 68 WELLS					13,114	11,131	14,131	10,241	9,394	11,602	20,658	23,536	24,455	20,573	20,149	21,874

TABLE NO. 2
VERIFIED EXTRACTIONS BY OWNERS
WHICH HAVE NOT FILED
WITH THE STATE WATER RESOURCES CONTROL BOARD

SANTA ANA RIVER WHITEWATER RIVER WATERSHEDS COOPERATIVE WATER RECORDATION PROGRAM

TABLE 2

VERIFIED EXTRACTIONS - NON-FILED

COLTON BASIN

RECRDTN NUMBER	STATE WELL NUMBER	WELL TYPE	LOCAL DESIGNATION	FC	-----BASE YEARS-----						-----CALENDAR YEAR EXTRACTIONS-----					
					1959	1960	1961	1962	1963	AVG	2008	2009	2010	2011	2012	AVG
VILLELLI ENTERPRISES																
0000201	01S/04W-28G	W	4	<input checked="" type="checkbox"/>	0	0	0	0	0	0	0	0	0	0	0	0
TOTALS FOR VILLELLI ENTERPRISES					0	0	0	0	0	0	0	0	0	0	0	0
VILLELLI ENTERPRISES																
0000202	01S/04W-28G	W	#5 DOMESTIC	<input checked="" type="checkbox"/>	0	0	0	0	0	0	0	0	0	0	0	0
TOTALS FOR VILLELLI ENTERPRISES					0	0	0	0	0	0	0	0	0	0	0	0
SEQUOIA COUNTRY CLUB																
0000203	01S/04W-07C01S	W	EDMUNDS	<input checked="" type="checkbox"/>	0	0	215	215	215	129	0	0	0	0	0	0
TOTALS FOR SEQUOIA COUNTRY CLUB					0	0	215	215	215	129	0	0	0	0	0	0
PERRY AND SONS																
0000204	01N/05W-29P	W		<input checked="" type="checkbox"/>						0	0	0	0	0	0	0
TOTALS FOR PERRY AND SONS										0	0	0	0	0	0	0
TOTALS FOR 4 WELLS					0	0	215	215	215	129	0	0	0	0	0	0

TABLE NO. 3
SUMMARY OF VERIFIED EXTRACTIONS
(FILED AND NON-FILED)
FROM COLTON BASIN AREA

WESTERN - SAN BERNARDINO WATERMASTER
TABLE 3
VERIFIED EXTRACTIONS - FILED AND NONFILED DETAIL
COLTON BASIN

RECRDTN NUMBER	STATE WELL NUMBER	WELL TYPE	LOCAL DESIGNATION	-----BASE YEARS-----						-----CALENDAR YEAR EXTRACTIONS-----					
				1959	1960	1961	1962	1963	AVG	2008	2009	2010	2011	2012	AVG
COLTON, CITY OF															
3603916	01S/04W-08Q04S	W	#29							0	0	0	0	0	0
3601255	01S/04W-18B	W	9	101	101	106	135	103	109	0	0	0	0	0	0
3601261	01S/04W-18F01S	W	17	761	880	752	394	474	652	1,414	1,053	1,304	1,321	1,152	1,249
3601259	01S/04W-18G01S	W	15	1,064	781	787	377	455	693	537	539	650	467	607	560
3603367	01S/04W-21K01S	W	#23						0	1,684	1,683	1,543	965	764	1,328
3602255	01S/04W-27L01S	W	KATZ/HOLLOW	283	283	283	283	0	226	0	0	0	0	0	0
3602881	01S/04W-27L03S	W	22						0	328	5	423	610	335	340
3602356	01S/04W-34H	W	5731- JAMES SULLIVAN	22	24	12	13	14	17	0	0	0	0	0	0
TOTALS FOR COLTON, CITY OF				2,231	2,069	1,940	1,202	1,046	1,698	3,963	3,280	3,920	3,363	2,858	3,477
FONTANA UNION WATER COMPANY															
3603060	01N/05W-29R15S	W	F13A (OLD FU #37)						0	768	1,828	1,477	1,629	1,590	1,458
3602129	01N/05W-30A	W	36	31	31	31	31	31	31	0	0	0	0	0	0
3603739	01N/05W-32A02S	W	F13B						0	1,617	1,990	1,851	1,411	1,124	1,599
3603764	01N/05W-33N01S	W	F49A						0	2,743	3,054	3,085	2,338	2,539	2,752
3603726	01N/06W-25A01S	W	F15A						0	1,184	1,608	1,369	1,007	1,053	1,244
3600589	01S/05W-04D01S	W	35	437	621	227	407	449	428	0	0	0	0	0	0
3600578	01S/05W-05A02S	W	23	0	0	429	0	0	86	0	0	0	0	0	0
3600577	01S/05W-05A03S	W	22	0	132	546	0	400	216	0	0	0	0	0	0
3603765	01S/05W-05A05S	W	F10C						0	2,191	2,562	2,475	1,456	1,965	2,130
TOTALS FOR FONTANA UNION WATER COMPANY				468	784	1,233	438	880	761	8,503	11,042	10,257	7,841	8,271	9,183
HAYES, GEO. G.															
3601141	01S/04W-18K01S	W	1	0	0	0	0	0	0	0	0	0	0	0	0
TOTALS FOR HAYES, GEO. G.				0	0	0	0	0	0	0	0	0	0	0	0
LA SIERRA WATER COMPANY															
3602228	01S/04W-18F01S	W	17						0	0	0	0	0	0	0
3602227	01S/04W-18G01S	W	15						0	0	0	0	0	0	0
TOTALS FOR LA SIERRA WATER COMPANY									0	0	0	0	0	0	0
LEDIG, ALFRED H															
3601383	01N/05W-18D	D		0	0	0	0	0	0	0	0	0	0	0	0

WESTERN - SAN BERNARDINO WATERMASTER
TABLE 3
VERIFIED EXTRACTIIONS - FILED AND NONFILED DETAIL
COLTON BASIN

RECRDTN NUMBER	STATE WELL NUMBER	WELL TYPE	LOCAL DESIGNATION	-----BASE YEARS-----						-----CALENDAR YEAR EXTRACTIIONS-----						
				1959	1960	1961	1962	1963	AVG	2008	2009	2010	2011	2012	AVG	
TOTALS FOR LEDIG, ALFRED H				0	0	0	0	0	0	0	0	0	0	0	0	0
MEEKS & DALEY WATER COMPANY																
3603950	01S/04W-21L05S	W	SPERRY WELL						0			0	101	0	20	
3601510	01S/04W-21N01S	W	36	2,168	23	465	1,185	339	836	883	298	0	0	0	236	
TOTALS FOR MEEKS & DALEY WATER COMPANY				2,168	23	465	1,185	339	836	883	298	0	101	0	256	
MELCHIORRE, ERIK																
3303122	02S/03W-07N02S	W	AG WELL						0	0	1	1	1	2	1	
3303121	02S/03W-07N03S	W	HOUSE						0	1	1	2	1	1	1	
TOTALS FOR MELCHIORRE, ERIK									0	1	2	3	2	3	2	
MONTECITO MEMORIAL PARK																
3603910	01S/04W-27Q	W	BARTON ROAD						0	175	144	134	169	169	158	
TOTALS FOR MONTECITO MEMORIAL PARK									0	175	144	134	169	169	158	
PATTERSON, JOHN A																
3600634	01S/04W-17M01S	W	PATTERSON	137	0	0	0	0	27	0	0	0	0	0	0	
TOTALS FOR PATTERSON, JOHN A				137	0	0	0	0	27	0	0	0	0	0	0	
PERRY AND SONS																
0000204	01N/05W-29P	W							0	0	0	0	0	0	0	
TOTALS FOR PERRY AND SONS									0	0	0	0	0	0	0	
RECHE CANYON MUTUAL WATER COMPANY																
3302055	02S/04W-11A01S	W	#1, WHITTER, SMALL						0	17	22	19	0	2	12	
3302054	02S/04W-11A02S	W	#2, 20 HP ADAMS-BIG						0	34	30	34	49	64	42	
3302326	02S/04W-11A03S	W	#3, 7200 MILTON CT						0	4	28	24	23	8	17	
TOTALS FOR RECHE CANYON MUTUAL WATER COMPANY									0	55	80	77	72	74	72	
RIALTO, CITY OF																
3602253	01N/05W-27D01S	W	RIALTO #1, CEDAR						0	0	0	0	0	0	0	
3601993	01N/05W-34B01S	W	RIALTO #2, HIGHLAND				723	600	265	0	0	0	0	0	0	
3602558	01N/05W-34M01S	W	RIALTO #3, AIRPORT						0	621	1,739	1,786	1,868	2,151	1,633	
3603576	01S/05W-02E01S	W	RIALTO #5						0	1,731	1,480	996	338	620	1,033	

**WESTERN - SAN BERNARDINO WATERMASTER
TABLE 3
VERIFIED EXTRACTIONS - FILED AND NONFILED DETAIL
COLTON BASIN**

RECRDTN NUMBER	STATE WELL NUMBER	WELL TYPE	LOCAL DESIGNATION	-----BASE YEARS-----						-----CALENDAR YEAR EXTRACTIONS-----					
				1959	1960	1961	1962	1963	AVG	2008	2009	2010	2011	2012	AVG
3603103	01S/05W-02G01S	W	RIALTO #6, ETIWANDA						0	0	0	0	0	0	0
3601264	01S/05W-03A01S	W	RIALTO #4 / DUNCAN	987	808	1,372	754	994	983	0	0	0	0	0	0
3602271	01S/05W-03J01S	W	TUDOR	160	160	160	160	160	160	0	0	0	0	0	0
3602269	01S/05W-03N02S	W	RIALTO #7, TUDOR		275	342	236	385	248	0	0	0	0	0	0
TOTALS FOR RIALTO, CITY OF				1,147	1,243	1,874	1,873	2,139	1,655	2,352	3,219	2,782	2,206	2,771	2,666
RIVERSIDE HIGHLAND WATER CO															
3601525	01S/04W-28K01S	W	CR #4	211	126	357	280	163	227	0	0	0	0	0	0
3602182	01S/04W-28K02S	W	CR 4-A						0	0	0	0	0	0	0
TOTALS FOR RIVERSIDE HIGHLAND WATER CO				211	126	357	280	163	227	0	0	0	0	0	0
RIVERSIDE, CITY OF															
3601481	01S/04W-21L01S	W	VAUGHN 1	39	135	1,378	498	593	529	0	0	0	0	0	0
3603255	01S/04W-21L04S	W	JOHNSON #4						0	0	0	0	0	0	0
3601496	01S/04W-21P	D	WARM CR	0	0	0	0	0	0	0	0	0	0	0	0
3601494	01S/04W-21P01S	W	JOHNSON 2	0	0	0	0	0	0	0	0	0	0	0	0
3601495	01S/04W-21Q01S	W	JOHNSON 3	0	0	0	0	0	0	0	0	0	0	0	0
3601480	01S/04W-21Q03S	W	JOHNSON 1	2,183	1,569	1,569	963	789	1,415	0	0	0	0	0	0
3601482	01S/04W-28C01S	W	MEEKS 1	649	461	539	374	425	490	0	0	0	0	0	0
3602208	01S/04W-28D01S	W	MILL						0	1	0	0	0	0	0
TOTALS FOR RIVERSIDE, CITY OF				2,871	2,165	3,486	1,835	1,807	2,433	1	0	0	0	0	0
SAN GABRIEL VALLEY WATER CO															
3603626	01S/05W-05A04S	W	F10B						0	1,974	1,730	1,946	1,936	1,910	1,899
TOTALS FOR SAN GABRIEL VALLEY WATER CO									0	1,974	1,730	1,946	1,936	1,910	1,899
SEQUOIA COUNTRY CLUB															
0000203	01S/04W-07C01S	W	EDMUNDS	0	0	215	215	215	129	0	0	0	0	0	0
TOTALS FOR SEQUOIA COUNTRY CLUB				0	0	215	215	215	129	0	0	0	0	0	0
SOUTHERN CALIFORNIA EDISON															
3602218	01S/04W-29H03S	W	COLTON	8	8	7	8	8	8	0	0	0	0	0	0
3601008	01S/05W-12A	W	1 AC #58	199	200	215	200	200	203	0	0	0	0	0	0
3601010	01S/05W-12A	W	2	0	0	0	0	0	0	0	0	0	0	0	0

**WESTERN - SAN BERNARDINO WATERMASTER
TABLE 3
VERIFIED EXTRACTIIONS - FILED AND NONFILED DETAIL
COLTON BASIN**

RECRDTN NUMBER	STATE WELL NUMBER	WELL TYPE	LOCAL DESIGNATION	-----BASE YEARS-----						-----CALENDAR YEAR EXTRACTIIONS-----					
				1959	1960	1961	1962	1963	AVG	2008	2009	2010	2011	2012	AVG
TOTALS FOR SOUTHERN CALIFORNIA EDISON				207	208	222	208	208	211	0	0	0	0	0	0
TAYLOR, JOHN S															
3600867	01N/05W-07P	W	TAYLOR 1	0	0	0	0	0	0	0	0	0	0	0	
3600868	01N/05W-07P	D		0	0	0	0	0	0	0	0	0	0	0	
TOTALS FOR TAYLOR, JOHN S				0	0	0	0	0	0	0	0	0	0	0	
VILLELLI ENTERPRISES															
3601550	01S/04W-28A05S	W	3	193	147	172	75	2	118	0	0	0	0	0	
0000201	01S/04W-28G	W	4	0	0	0	0	0	0	0	0	0	0	0	
0000202	01S/04W-28G	W	#5 DOMESTIC	0	0	0	0	0	0	0	0	0	0	0	
3601548	01S/04W-28G01S	W	1	246	171	209	105	41	154	0	0	0	0	0	
TOTALS FOR VILLELLI ENTERPRISES				439	318	381	180	43	272	0	0	0	0	0	
WEST VALLEY WATER DIST															
3601691	01N/05W-17G01S	W	#23 / FONTANA RNCH 3	116	43	15	54	15	49	0	0	0	0	0	
3603771	01N/05W-17G02S	W	#23A						0	0	0	0	0	0	
3601689	01N/05W-17K01S	W	#21 / FONTANA RNCH 1	3	0	0	1	0	1	0	0	0	0	0	
3601931	01N/05W-17K02S	W	#24 / FONTANA RNCH 4		84	115	95	132	85	494	523	606	661	414	
3603770	01N/05W-27B01S	W	#22A LINDEN VINEYARD						0	0	0	0	0	0	
3601690	01N/05W-28J01S	W	#22 / FONTANA RNCH 2	0	0	0	0	0	0	0	0	0	0	0	
3603946	01N/06W-24C01S	W	#54						0	795	1,466	1,310	793	1,205	
3600309	01S/05W-02C01S	W	#10 BASELINE WILLOW	1,222	1,032	837	763	825	936	0	0	0	0	0	
3600311	01S/05W-02K01S	W	#11 VICTORIA/WILLOW	0	1,096	1,123	563	1,042	765	0	0	1,562	1,296	234	
3603465	01S/05W-03A02S	W	#33 SHOP						0	1,315	1,715	1,408	1,293	1,325	
3601001	01S/05W-12L01S	W	#16 / BOYD	1,418	1,145	1,453	1,089	627	1,146	147	37	450	840	915	
3600995	01S/05W-12N01S	W	#17 ACACIA/MERREL	476	795	630	475	128	501	0	0	0	0	0	
TOTALS FOR WEST VALLEY WATER DIST				3,235	4,195	4,173	3,040	2,769	3,482	2,751	3,741	5,336	4,883	4,093	
TOTALS FOR 72 WELLS				13,114	11,131	14,346	10,456	9,609	11,731	20,658	23,536	24,455	20,573	20,149	21,874

**WESTERN - SAN BERNARDINO WATERMASTER
TABLE 3
VERIFIED EXTRACTION, SUMMARY - FILED AND NON-FILED
COLTON BASIN**

	-----BASE YEARS-----						-----CALENDAR YEAR EXTRACTIONS-----					
	1959	1960	1961	1962	1963	AVG	2008	2009	2010	2011	2012	AVG
COLTON, CITY OF	2,231	2,069	1,940	1,202	1,046	1,698	3,963	3,280	3,920	3,363	2,858	3,477
FONTANA UNION WATER COMPANY	468	784	1,233	438	880	761	8,503	11,042	10,257	7,841	8,271	9,183
HAYES, GEO. G.	0	0	0	0	0	0	0	0	0	0	0	0
LA SIERRA WATER COMPANY						0	0	0	0	0	0	0
LEDIG, ALFRED H	0	0	0	0	0	0	0	0	0	0	0	0
MEEKS & DALEY WATER COMPANY	2,168	23	465	1,185	339	836	883	298	0	101	0	256
MELCHIORRE, ERIK						0	1	2	3	2	3	2
MONTECITO MEMORIAL PARK						0	175	144	134	169	169	158
PATTERSON, JOHN A	137	0	0	0	0	27	0	0	0	0	0	0
PERRY AND SONS						0	0	0	0	0	0	0
RECHE CANYON MUTUAL WATER COMPANY						0	55	80	77	72	74	72
RIALTO, CITY OF	1,147	1,243	1,874	1,873	2,139	1,655	2,352	3,219	2,782	2,206	2,771	2,666
RIVERSIDE HIGHLAND WATER CO	211	126	357	280	163	227	0	0	0	0	0	0
RIVERSIDE, CITY OF	2,871	2,165	3,486	1,835	1,807	2,433	1	0	0	0	0	0
SAN GABRIEL VALLEY WATER CO						0	1,974	1,730	1,946	1,936	1,910	1,899
SEQUOIA COUNTRY CLUB	0	0	215	215	215	129	0	0	0	0	0	0
SOUTHERN CALIFORNIA EDISON	207	208	222	208	208	211	0	0	0	0	0	0
TAYLOR, JOHN S	0	0	0	0	0	0	0	0	0	0	0	0
VILLELLI ENTERPRISES	439	318	381	180	43	272	0	0	0	0	0	0
WEST VALLEY WATER DIST	3,235	4,195	4,173	3,040	2,769	3,482	2,751	3,741	5,336	4,883	4,093	4,161
TOTALS FOR ALL WELLS	13,114	11,131	14,346	10,456	9,609	11,731	20,658	23,536	24,455	20,573	20,149	21,874

TABLE NO. 4

GROUNDWATER EXTRACTIONS BY RIVERSIDE COUNTY ENTITIES
FROM COLTON BASIN AREA
FOR USE IN RIVERSIDE & SAN BERNARDINO COUNTIES
DURING THE 5-YEAR BASE PERIOD 1959 THROUGH 1963
AND CALENDAR YEARS 1976 THROUGH THE CURRENT YEAR

TABLE NO. 4

GROUNDWATER EXTRACTIONS BY RIVERSIDE COUNTY ENTITIES FROM COLTON BASIN AREA FOR USE IN RIVERSIDE
AND SAN BERNARDINO COUNTIES DURING THE
FIVE-YEAR BASE PERIOD 1959 THROUGH 1963
AND CALENDAR YEARS 1976 THROUGH THE CURRENT YEAR

CLASSIFIED ACCORDING TO SERVICE AREA
(Quantities in Acre Feet)

EXTRACTIONS FROM THE COLTON BASIN AREA FOR USE WITHIN AND EXPORT THEREFROM

PLAINTIFFS	1959			1960			1961			1962			1963			5-Year Average		
	Total Extract	Del. in S.B. Co.	Del. in Riv. Co.	Total Extract	Del. in S.B. Co.	Del. in Riv. Co.	Total Extract	Del. in S.B. Co.	Del. in Riv. Co.	Total Extract	Del. in S.B. Co.	Del. in Riv. Co.	Total Extract	Del. in S.B. Co.	Del. in Riv. Co.	Total Extract	Del. in S.B. Co.	Del. in Riv. Co.
CITY OF RIVERSIDE Dom & Irrig.	2,871	41	2,830	2,165	28	2,137	3,486	0	3,486	1,835	0	1,835	1,807	7	1,800	2,433	15	2,418
MEEKS & DALEY WATER CO.	2,168	88	2,080	23	1	22	465	18	447	1,185	57	1,128	339	13	326	836	35	801
RIVERSIDE HIGHLAND WATER CO.	211	50	161	126	27	99	357	107	250	280	96	184	163	47	116	227	65	162
TOTALS	5,250	179	5,071	2,314	56	2,258	4,308	125	4,183	3,300	153	3,147	2,309	67	2,242	3,496	115	3,381

Total Extract -- TOTAL EXTRACTIONS.
Del in S.B. Co. -- DELIVERY WITHIN SAN BERNARDINO COUNTY.
Del. in Riv. Co. -- DELIVERY WITHIN RIVERSIDE COUNTY.

See Report of the Watermaster, Volume 5, Distribution of Extractions, Chapter I, Table No. 37.
Same as Table 39-A, Volume 5.

TABLE NO. 4

GROUNDWATER EXTRACTIONS BY RIVERSIDE COUNTY ENTITIES FROM COLTON BASIN AREA FOR USE IN RIVERSIDE
AND SAN BERNARDINO COUNTIES DURING THE
FIVE-YEAR BASE PERIOD 1959 THROUGH 1963
AND CALENDAR YEARS 1976 THROUGH THE CURRENT YEAR

CLASSIFIED ACCORDING TO SERVICE AREA
(Quantities in Acre Feet)

EXTRACTIONS FROM COLTON BASIN AREA FOR USE WITHIN AND EXPORT THEREFROM

PLAINTIFFS	1971			1972			1973			1974			1975		
	Total Extract	Del. in S.B. Co.	Del. in Riv. Co.	Total Extract	Del. in S.B. Co.	Del. in Riv. Co.	Total Extract	Del. in S.B. Co.	Del. in Riv. Co.	Total Extract	Del. in S.B. Co.	Del. in Riv. Co.	Total Extract	Del. in S.B. Co.	Del. in Riv. Co.
CITY OF RIVERSIDE Dom & Irrig.	2,696	0	2,696	2,521	0	2,521	101	0	101	1,386	0	1,386	2,545	0	2,545
MEEKS & DALEY WATER CO.	0	0	0	0	0	0	484	41	443	0	0	0	1,350	98	1,252
RIVERSIDE HIGHLAND WATER CO.	256	248	8	285	271	14	212	206	6	282	273	9	300	291	9
RECHE CANYON MUTUAL WATER CO.	73	-	73	76	-	76	65	-	65	69	-	69	67	-	67
TOTALS	3,025	248	2,777	2,882	271	2,611	862	247	615	1,737	273	1,464	4,262	389	3,873

Total Extract -- TOTAL EXTRACTIONS.
Del in S.B. Co. -- DELIVERY WITHIN SAN BERNARDINO COUNTY.
Del. in Riv. Co. -- DELIVERY WITHIN RIVERSIDE COUNTY.

See Report of the Watermaster, Volume 5, Distribution of Extractions, Chapter I, Table No. 37.
Same as Table 39A, Volume 5.

TABLE NO. 4

GROUNDWATER EXTRACTIONS BY RIVERSIDE COUNTY ENTITIES FROM COLTON BASIN AREA FOR USE IN RIVERSIDE
AND SAN BERNARDINO COUNTIES DURING THE
FIVE-YEAR BASE PERIOD 1959 THROUGH 1963
AND CALENDAR YEARS 1976 THROUGH THE CURRENT YEAR

CLASSIFIED ACCORDING TO SERVICE AREA
(Quantities in Acre Feet)

EXTRACTIONS FROM COLTON BASIN AREA FOR USE WITHIN AND EXPORT THEREFROM

PLAINTIFFS	1976			1977			1978			1979			1980		
	Total Extract	Del. in S.B. Co.	Del. in Riv. Co.	Total Extract	Del. in S.B. Co.	Del. in Riv. Co.	Total Extract	Del. in S.B. Co.	Del. in Riv. Co.	Total Extract	Del. in S.B. Co.	Del. in Riv. Co.	Total Extract	Del. in S.B. Co.	Del. in Riv. Co.
CITY OF RIVERSIDE Dom & Irrig.	853	0	853	295	0	295	464	0	464	5	0	5	5	0	5
MEEKS & DALEY WATER CO.	1,860	100	1,760	2,018	125	1,893	422	78	344	1,698	104	1,594	0	0	0
RIVERSIDE HIGHLAND WATER CO.	170	165	5	332	322	10	270	260	10	191	184	7	0	0	0
RECHE CANYON MUTUAL WATER CO.	70	-	70	71	-	71	77	-	77	76	-	76	71	-	71
TOTALS	2,953	265	2,688	2,716	447	2,269	1,233	338	895	1,970	288	1,682	76	0	76

Total Extract -- TOTAL EXTRACTIONS.

Del in S.B. Co. -- DELIVERY WITHIN SAN BERNARDINO COUNTY.

Del. in Riv. Co. -- DELIVERY WITHIN RIVERSIDE COUNTY.

See Report of the Watermaster, Volume 5, Distribution of Extractions, Chapter I, Table No. 37.

Same as Table 39A, Volume 5.

TABLE NO. 4

GROUNDWATER EXTRACTIONS BY RIVERSIDE COUNTY ENTITIES FROM COLTON BASIN AREA FOR USE IN RIVERSIDE
AND SAN BERNARDINO COUNTIES DURING THE
FIVE-YEAR BASE PERIOD 1959 THROUGH 1963
AND CALENDAR YEARS 1976 THROUGH THE CURRENT YEAR

CLASSIFIED ACCORDING TO SERVICE AREA
(Quantities in Acre Feet)

EXTRACTIONS FROM COLTON BASIN AREA FOR USE WITHIN AND EXPORT THEREFROM

PLAINTIFFS	1981			1982			1983			1984			1985		
	Total	Del. in	Del. in	Total	Del. in	Del. in	Total	Del. in	Del. in	Total	Del. in	Del. in	Total	Del. in	Del. in
	Extract	S.B. Co.	Riv. Co.	Extract	S.B. Co.	Riv. Co.	Extract	S.B. Co.	Riv. Co.	Extract	S.B. Co.	Riv. Co.	Extract	S.B. Co.	Riv. Co.
CITY OF RIVERSIDE Dom & Irrig.	77	0	77	57	-	57	0	-	0	0	-	0	695	-	695
MEEKS & DALEY WATER CO.	0	0	0	910	68	842	50	37	13	1,383	125	1,258	1,554	113	1,441
RIVERSIDE HIGHLAND WATER CO.	0	0	0	0	0	0	0	0	0	83	80	3	675	651	24
RECHE CANYON MUTUAL WATER CO.	96	-	96	0	-	82	82	-	82	80	-	80	83	-	83
TOTALS	173	0	173	967	68	981	132	37	95	1,546	205	1,341	3,007	764	2,243

Total Extract -- TOTAL EXTRACTIONS.
Del in S.B. Co. -- DELIVERY WITHIN SAN BERNARDINO COUNTY.
Del. in Riv. Co. -- DELIVERY WITHIN RIVERSIDE COUNTY.

See Report of the Watermaster, Volume 5, Distribution of Extractions, Chapter I, Table No. 37.
Same as Table 39A, Volume 5.

TABLE NO. 4

GROUNDWATER EXTRACTIONS BY RIVERSIDE COUNTY ENTITIES FROM COLTON BASIN AREA FOR USE IN RIVERSIDE
AND SAN BERNARDINO COUNTIES DURING THE
FIVE-YEAR BASE PERIOD 1959 THROUGH 1963
AND CALENDAR YEARS 1976 THROUGH THE CURRENT YEAR

CLASSIFIED ACCORDING TO SERVICE AREA
(Quantities in Acre Feet)

EXTRACTIONS FROM COLTON BASIN AREA FOR USE WITHIN AND EXPORT THEREFROM

PLAINTIFFS	1986			1987			1988			1989			1990		
	Total Extract	Del. in S.B. Co.	Del. in Riv. Co.	Total Extract	Del. in S.B. Co.	Del. in Riv. Co.	Total Extract	Del. in S.B. Co.	Del. in Riv. Co.	Total Extract	Del. in S.B. Co.	Del. in Riv. Co.	Total Extract	Del. in S.B. Co.	Del. in Riv. Co.
CITY OF RIVERSIDE Dom & Irrig.	0	-	0	0	-	0	0	-	0	519	-	519	131	-	131
MEEKS & DALEY WATER CO.	1,575	115	1,460	1,560	114	1,446	1,754	150	1,604	1,538	157	1,381	1,691	306	1,385
RIVERSIDE HIGHLAND WATER CO.	721	691	30	471	451	20	256	242	14	158	142	16	109	62	47
RECHE CANYON MUTUAL WATER CO.	88	-	88	90	-	90	89	-	89	89	-	89	89	-	89
TOTALS	2,384	806	1,578	2,121	565	1,556	2,099	392	1,707	2,304	299	2,005	2,020	368	1,652

Total Extract -- TOTAL EXTRACTIONS.
Del in S.B. Co. -- DELIVERY WITHIN SAN BERNARDINO COUNTY.
Del. in Riv. Co. -- DELIVERY WITHIN RIVERSIDE COUNTY.

See Report of the Watermaster, Volume 5, Distribution of Extractions, Chapter I, Table No. 37.
Same as Table 39A, Volume 5.

TABLE NO. 4

GROUNDWATER EXTRACTIONS BY RIVERSIDE COUNTY ENTITIES FROM COLTON BASIN AREA FOR USE IN RIVERSIDE
AND SAN BERNARDINO COUNTIES DURING THE
FIVE-YEAR BASE PERIOD 1959 THROUGH 1963
AND CALENDAR YEARS 1976 THROUGH THE CURRENT YEAR

CLASSIFIED ACCORDING TO SERVICE AREA
 (Quantities in Acre Feet)

EXTRACTIONS FROM COLTON BASIN AREA FOR USE WITHIN AND EXPORT THEREFROM

PLAINTIFFS	1991			1992			1993			1994			1995		
	Total Extract	Del. in S.B. Co.	Del. in Riv. Co.	Total Extract	Del. in S.B. Co.	Del. in Riv. Co.	Total Extract	Del. in S.B. Co.	Del. in Riv. Co.	Total Extract	Del. in S.B. Co.	Del. in Riv. Co.	Total Extract	Del. in S.B. Co.	Del. in Riv. Co.
CITY OF RIVERSIDE Dom & Irrig.	428	-	428	307	-	307	311	-	311	466	-	466	171	-	171
MEEKS & DALEY WATER CO	1,530	204	1,326	1,209	176	1,033	0	0	0	586	95	491	344	126	218
RIVERSIDE HIGHLAND WATER CO.	4	2	2	91	51	40	0	0	0	0	0	0	0	0	0
RECHE CANYON MUTUAL WATER CO.	79	-	79	75	-	75	85	-	85	109	-	109	100	-	100
TOTALS	2,041	206	1,835	1,682	227	1,455	396	0	396	1,161	95	1,066	615	126	489

Total Extract -- TOTAL EXTRACTIONS.
 Del in S.B. Co. -- DELIVERY WITHIN SAN BERNARDINO COUNTY.
 Del. in Riv. Co. -- DELIVERY WITHIN RIVERSIDE COUNTY.

See Report of the Watermaster, Volume 5, Distribution of Extractions, Chapter I, Table No. 37.
 Same as Table 39A, Volume 5.

TABLE NO. 4

GROUNDWATER EXTRACTIONS BY RIVERSIDE COUNTY ENTITIES FROM COLTON BASIN AREA FOR USE IN RIVERSIDE
AND SAN BERNARDINO COUNTIES DURING THE
FIVE-YEAR BASE PERIOD 1959 THROUGH 1963
AND CALENDAR YEARS 1976 THROUGH THE CURRENT YEAR

CLASSIFIED ACCORDING TO SERVICE AREA

(Quantities in Acre Feet)

EXTRACTIONS FROM COLTON BASIN AREA FOR USE WITHIN AND EXPORT THEREFROM

PLAINTIFFS	1996			1997			1998			1999			2000		
	Total Extract	Del. in S.B. Co.	Del. in Riv. Co.	Total Extract	Del. in S.B. Co.	Del. in Riv. Co.	Total Extract	Del. in S.B. Co.	Del. in Riv. Co.	Total Extract	Del. in S.B. Co.	Del. in Riv. Co.	Total Extract	Del. in S.B. Co.	Del. in Riv. Co.
CITY OF RIVERSIDE Dom & Irrig.	208	0	208	633	0	633	142	0	142	7	0	7	128	0	128
MEEKS & DALEY WATER CO	362	78	284	484	81	403	88	32	56	1,066	222	844	102	73	29
RIVERSIDE HIGHLAND WATER CO.	0	0	0	0	0	0	0	0	0	0	0	0	0	0	0
RECHE CANYON MUTUAL WATER CO.	85	0	85	105	0	105	53	0	53	61	0	61	56	0	56
TOTALS	655	78	577	1,222	81	1,141	283	32	251	1,134	222	912	286	73	213

Total Extract -- TOTAL EXTRACTIONS.

Del in S.B. Co. -- DELIVERY WITHIN SAN BERNARDINO COUNTY.

Del. in Riv. Co. -- DELIVERY WITHIN RIVERSIDE COUNTY.

See Report of the Watermaster, Volume 5, Distribution of Extractions, Chapter I, Table No. 37.

Same as Table 39A, Volume 5.

TABLE NO. 4
GROUNDWATER EXTRACTIONS BY RIVERSIDE COUNTY ENTITIES FROM COLTON BASIN AREA FOR USE IN RIVERSIDE
AND SAN BERNARDINO COUNTIES DURING THE
FIVE-YEAR BASE PERIOD 1959 THROUGH 1963
AND CALENDAR YEARS 1976 THROUGH THE CURRENT YEAR

CLASSIFIED ACCORDING TO SERVICE AREA
 (Quantities in Acre Feet)

EXTRACTIONS FROM COLTON BASIN AREA FOR USE WITHIN AND EXPORT THEREFROM

PLAINTIFFS	2001			2002			2003			2004			2005		
	Total	Del. in	Del. in	Total	Del. in	Del. in	Total	Del. in	Del. in	Total	Del. in	Del. in	Total	Del. in	Del. in
	Extract	S.B. Co.	Riv. Co.	Extract	S.B. Co.	Riv. Co.	Extract	S.B. Co.	Riv. Co.	Extract	S.B. Co.	Riv. Co.	Extract	S.B. Co.	Riv. Co.
CITY OF RIVERSIDE Dom & Irrig.	0	0	0	0	0	0	171	0	171	0	0	0	0	0	0
MEEKS & DALEY WATER CO	285	168	117	1322	116	1206	844	18	826	120	7	113	30	3	27
RIVERSIDE HIGHLAND WATER CO.	0	0	0	0	0	0	0	0	0	0	0	0	0	0	0
RECHE CANYON MUTUAL WATER CO.	48	0	48	73	0	73	65	0	65	59	0	59	57	0	57
TOTALS	333	168	165	1,395	116	1,279	1,080	18	1,062	179	7	172	87	3	84

Total Extract -- TOTAL EXTRACTIONS.
 Del in S.B. Co. -- DELIVERY WITHIN SAN BERNARDINO COUNTY.
 Del. in Riv. Co. -- DELIVERY WITHIN RIVERSIDE COUNTY.

See Report of the Watermaster, Volume 5, Distribution of Extractions, Chapter I, Table No. 37.
 Same as Table 39A, Volume 5.

TABLE NO. 4

GROUNDWATER EXTRACTIONS BY RIVERSIDE COUNTY ENTITIES FROM COLTON BASIN AREA FOR USE IN RIVERSIDE
AND SAN BERNARDINO COUNTIES DURING THE
FIVE-YEAR BASE PERIOD 1959 THROUGH 1963
AND CALENDAR YEARS 1976 THROUGH THE CURRENT YEAR

CLASSIFIED ACCORDING TO SERVICE AREA
(Quantities in Acre Feet)

EXTRACTIONS FROM COLTON BASIN AREA FOR USE WITHIN AND EXPORT THEREFROM

PLAINTIFFS	2006			2007			2008			2009			2010		
	Total Extract	Del. in S.B. Co.	Del. in Riv. Co.	Total Extract	Del. in S.B. Co.	Del. in Riv. Co.	Total Extract	Del. in S.B. Co.	Del. in Riv. Co.	Total Extract	Del. in S.B. Co.	Del. in Riv. Co.	Total Extract	Del. in S.B. Co.	Del. in Riv. Co.
CITY OF RIVERSIDE Dom & Irrig.	122	-	122	0	-	0	1	-	1	0	-	0	0	-	0
MEEKS & DALEY WATER CO	222	0	222	682	0	682	883	-	883	298	-	298	0	-	0
RIVERSIDE HIGHLAND WATER CO.	-	-	-	-	-	-	-	-	-	-	-	-	-	-	-
RECHE CANYON MUTUAL WATER CO.	68	-	68	60	-	60	55	-	55	80	-	80	77	-	77
TOTALS	412	0	412	742	0	742	939	0	939	378	0	378	77	0	77

Total Extract -- TOTAL EXTRACTIONS.

Del in S.B. Co. -- DELIVERY WITHIN SAN BERNARDINO COUNTY.

Del. in Riv. Co. -- DELIVERY WITHIN RIVERSIDE COUNTY.

See Report of the Watermaster, Volume 5, Distribution of Extractions, Chapter I, Table No. 37.

Same as Table 39A, Volume 5.

TABLE NO. 4

GROUNDWATER EXTRACTIONS BY RIVERSIDE COUNTY ENTITIES FROM COLTON BASIN AREA FOR USE IN RIVERSIDE
AND SAN BERNARDINO COUNTIES DURING THE
FIVE-YEAR BASE PERIOD 1959 THROUGH 1963
AND CALENDAR YEARS 1976 THROUGH THE CURRENT YEAR

CLASSIFIED ACCORDING TO SERVICE AREA
(Quantities in Acre Feet)

EXTRACTIONS FROM COLTON BASIN AREA FOR USE WITHIN AND EXPORT THEREFROM

PLAINTIFFS	2011			2012			2013			2014			2015		
	Total Extract	Del. in S.B. Co.	Del. in Riv. Co.	Total Extract	Del. in S.B. Co.	Del. in Riv. Co.	Total Extract	Del. in S.B. Co.	Del. in Riv. Co.	Total Extract	Del. in S.B. Co.	Del. in Riv. Co.	Total Extract	Del. in S.B. Co.	Del. in Riv. Co.
CITY OF RIVERSIDE Dom & Irrig.	0	-	0	0	-	0	-	-	-	-	-	-	-	-	-
MEEKS & DALEY WATER CO.	101	-	101	0	-	0	-	-	-	-	-	-	-	-	-
RIVERSIDE HIGHLAND WATER CO.	-	-	-	-	-	-	-	-	-	-	-	-	-	-	-
RECHE CANYON MUTUAL WATER CO.	72	-	72	74	-	74	-	-	-	-	-	-	-	-	-
TOTALS	173	0	173	74	0	74									

Total Extract -- TOTAL EXTRACTIONS
Del in S.B. Co. -- DELIVERY WITHIN SAN BERNARDINO COUNTY
Del. in Riv. Co. -- DELIVERY WITHIN RIVERSIDE COUNTY

See Table 37 for figures
Same as Table 39A, Volume 5.

TABLE NO. 5

GROUNDWATER EXTRACTIONS FROM COLTON BASIN AREA
BY SAN BERNARDINO COUNTY ENTITIES
FOR USE IN SAN BERNARDINO COUNTY
DURING THE 5-YEAR BASE PERIOD 1959 THROUGH 1963
AND CALENDAR YEARS 1971 THROUGH THE CURRENT YEAR

TABLE NO. 5

page 1 of 2

GROUNDWATER EXTRACTIONS FROM COLTON BASIN AREA
BY SAN BERNARDINO COUNTY ENTITIES FOR USE IN SAN BERNARDINO COUNTY
DURING THE 5-YEAR BASE PERIOD 1959 THROUGH 1963
AND CALENDAR YEARS 1971 THROUGH THE CURRENT YEAR

(All Quantities in Acre Feet)

Verified Extractions from Colton Basin Area

Calendar Year	Total Production from the Basin	Produced by Riverside Co. Entities	Accumulated Riverside Co. Entities	Produced by San Bernardino Co. Entities
	(1)	(2)	(2a)	(3) = (1) - (2)
1959	13,114	5,250		7,864
1960	11,131	2,314		8,817
1961	14,346	4,308		10,038
1962	10,456	3,300		7,156
1963	9,609	2,309		7,300
Total	58,656	17,481		41,175
5-Year Avg.	11,731	3,496		8,235
1971	11,388	3,025	3,025	8,363
1972	10,414	2,882	5,907	7,532
1973	7,844	862	6,769	6,982
1974	8,906	1,737	8,506	7,169
1975	11,083	4,262	12,768	6,821
1976	11,558	2,953	15,721	8,605
1977	8,777	2,716	18,437	6,061
1978	7,663	1,233	19,670	6,430
1979	7,194	1,970	21,640	5,224
1980	5,681	76	21,716	5,605
1981	6,348	173	21,889	6,175
1982	6,499	1,049	22,938	5,450
1983	4,735	132	23,070	4,603
1984	8,987	1,546	24,616	7,441
1985	10,149	3,007	27,623	7,142
1986	10,035	2,384	30,007	7,651
1987	13,175	2,121	32,128	11,054
1988	13,552	2,099	34,227	11,453
1989	14,103	2,304	36,531	11,799
1990	17,571	2,020	38,551	15,551
1991	14,323	2,041	40,592	12,282
1992	16,750	1,682	42,274	15,068
1993	14,977	396	42,670	14,581
1994	15,813 4)	1,161	43,831	14,652
1995	17,308 1) 4)	615	44,446	16,693 1) 4)
1996	17,040 4)	655	45,101	16,385
1997	14,498 2) 4)	1,222	46,323	13,276
1998	10,972 4)	283	46,606	10,689
1999	12,564 4)	1,134	47,740	11,430
2000	13,123 4)	286 4)	48,026	12,837 4)
2001	16,389 3) 4)	333	48,359	16,056
2002	19,161 4)	1,395	49,754	17,766
2003	25,656	1,080	50,834	24,576
2004	24,346	179	51,013	24,167
2005	18,814	87	51,100	18,727

From Table 38, Volume 5, Columns 1,4, calc, 5

Data for Column 1 is from Table 3; Column 2 is from Total Extractions Table 4.

1) Corrected during 1996 Verification.

2) Corrected during 1998 Verification.

3) Corrected during 2002 verification, backfiled on new San Gabriel well, 3603739

4) Corrected during 2003 verification, backfiled West Valley #33 from 1994-2002

TABLE NO. 5

GROUNDWATER EXTRACTIONS FROM COLTON BASIN AREA
BY SAN BERNARDINO COUNTY ENTITIES FOR USE IN SAN BERNARDINO COUNTY
DURING THE 5-YEAR BASE PERIOD 1959 THROUGH 1963
AND CALENDAR YEARS 1971 THROUGH THE CURRENT YEAR

(All Quantities in Acre Feet)

Verified Extractions from Colton Basin Area

Calendar Year	Total Production from the Basin	Produced by Riverside Co. Entities	Accumulated Riverside Co. Entities	Produced by San Bernardino Co. Entities
	(1)	(2)	(2a)	(3) = (1) - (2)
1959	13,114	5,250		7,864
1960	11,131	2,314		8,817
1961	14,346	4,308		10,038
1962	10,456	3,300		7,156
1963	9,609	2,309		7,300
Total	58,656	17,481		41,175
5-Year Avg.	11,731	3,496		8,235
2006	17,566	412	51,512	17,154
2007	20,988	742	52,254	20,246
2008	20,658	939	53,193	19,719
2009	23,536	378	53,571	23,158
2010	24,455	77	53,648	24,378
2011	20,573	173	53,821	20,400
2012	20,149	74	53,895	20,075
2013				
2014				
2015				
2016				
2017				
2018				
2019				
2020				
2021				
2022				
2023				
2024				
2025				
2026				
2027				
2028				
2029				
2030				
2031				
2032				
2033				
2034				
2035				
2036				
2037				
2038				
2039				
2040				

From Table 38, Volume 5, Columns 1, 4, (calc), 5
 Data for Column 1 must match Table 3; Column 2 is from Total Extractions Table 4.

**WESTERN - SAN BERNARDINO WATERMASTER
FOR
WESTERN MUNICIPAL WATER DISTRICT et al.
vs.
EAST SAN BERNARDINO COUNTY WATER DISTRICT et al.
CASE NO. 78426 - COUNTY OF RIVERSIDE**

VOLUME 3 - 2012

**VERIFIED EXTRACTIONS FROM THE
RIVERSIDE BASIN AREA WITHIN
SAN BERNARDINO COUNTY
FOR
CALENDAR YEARS 1959-1963 & 2008-2012**

**ANNUAL ACCOUNTING
FOR INDIVIDUAL WELLS**

April 1, 2014

WATERMASTER
Douglas D. Headrick
John V. Rossi

REPORT OF WATERMASTER

Western Municipal Water District of Riverside County, et al.
Plaintiffs

vs.

East San Bernardino County Water District, et al.
Defendants

Superior Court of Riverside County

Case No. 78426

Volume 3 - 2012

VERIFIED EXTRACTIONS FROM
RIVERSIDE BASIN AREA WITHIN
SAN BERNARDINO COUNTY
for
CALENDAR YEARS 1959-1963 AND 2008-2012

ANNUAL ACCOUNTING
FOR INDIVIDUAL WELLS

April 1, 2014

WATERMASTER
Douglas D. Headrick
John V. Rossi

VOLUME 1A - 2012

TABLE OF CONTENTS

<u>CHAPTER I</u>	<u>PAGE</u>
PLAINTIFFS EXTRACTIONS FROM THE SAN BERNARDINO BASIN AREA FOR CALENDAR YEARS 1959-1963 AND 2008-2012	i
 <u>CHAPTER II</u>	
PLAINTIFFS EXTRACTIONS FROM THE SAN BERNARDINO BASIN AREA FOR CALENDAR YEARS 1959-1963 AND 2008-2012 AND DISTRIBUTION BY SERVICE AREA	iii
 MAP - SAN BERNARDINO BASIN AREA - PLAINTIFFS	 1
GRAPH - VERIFIED WATER PRODUCTION BY PLAINTIFFS IN THE SAN BERNARDINO BASIN AREA FOR CALENDAR YEARS 1959-63 and 1971 THROUGH PRESENT	 2
SAN BERNARDINO BASIN AREA, CROSS INDEX BY OWNER - PLAINTIFFS	 3
SAN BERNARDINO BASIN AREA, CROSS INDEX BY STATE WELL NUMBER - PLAINTIFFS	 8
SAN BERNARDINO BASIN AREA, CROSS INDEX BY RECORDATION NUMBER - PLAINTIFFS	 13
 <u>TABLE NO. 1</u>	
VERIFIED EXTRACTIONS BY OWNERS (PLAINTIFFS) WHICH HAVE FILINGS WITH THE WATERMASTER FOR SAN BERNARDINO BASIN AREA	 18
 <u>TABLE NO. 2</u>	
SUMMARY OF EXTRACTIONS (FILED AND NON-FILED BY ALL PLAINTIFFS) FOR SAN BERNARDINO BASIN AREA	 24

TABLE NO. 3

EXTRACTIONS BY PLAINTIFFS FROM THE SAN BERNARDINO
BASIN AREA FOR AVERAGE OF FIVE-YEAR PERIOD ENDING
WITH 1963 AND CALENDAR YEARS 1971 THROUGH CURRENT
YEAR CLASSIFIED ACCORDING TO SERVICE AREA 26

TABLE NO. 4

TOTAL EXTRACTIONS BY PLAINTIFFS FROM
SAN BERNARDINO BASIN AREA 37

TABLE NO. 5

EXTRACTIONS BY PLAINTIFFS FROM THE SAN BERNARDINO BASIN
AREA FOR DELIVERIES IN SAN BERNARDINO BASIN AREA 40

TABLE NO. 6

EXTRACTIONS BY PLAINTIFFS FROM THE SAN BERNARDINO
BASIN AREA FOR DELIVERIES IN COLTON AND RIVERSIDE
BASINS IN SAN BERNARDINO COUNTY 43

TABLE NO. 7

EXTRACTIONS BY PLAINTIFFS FROM THE SAN BERNARDINO
BASIN AREA FOR DELIVERIES OUTSIDE SAN BERNARDINO
VALLEY. 46

VOLUME 1A - 2012

CHAPTER I

PLAINTIFFS EXTRACTIONS FROM THE
SAN BERNARDINO BASIN AREA FOR
CALENDAR YEARS 1959-1963 AND 2008-2012

The provisions of Paragraph IV (B,3) of the Judgment in Case No. 78426 entered April 17, 1969, entitled "San Bernardino Basin Area Rights and Replenishment (Annual Adjusted Rights of Plaintiffs)" provides as follows:

VI(B,3) "In any five-year period, each Plaintiff shall have the right to extract from the San Bernardino Basin area for use in each service area designated in Table B-1 an amount of water equal to five times its adjusted right for such service area; provided, however, that extractions by each Plaintiff in any year in any service area shall not exceed such Plaintiff's adjusted right for that service area by more than 30 percent."

Compliance with this provision of the Judgment requires that an accounting of the total actual extractions of surface and groundwater by the Plaintiffs-City of Riverside, The Gage Canal Co., Meeks & Daley Water Co., Agua Mansa Water Co., Riverside Highland Water Co., and the Regents of the University of California-from the San Bernardino Basin Area be made annually. Included in this Volume 1A-2012 is the verified accounting of such extractions by the Plaintiffs for the Calendar years 2008 through 2012. The extractions for the five-year base period ending with 1963 are also included for comparison.

Three indexes are included which provide a cross index by owner's name, State Water Resources Control Board Well Recordation Number, and State Well Number. Each index shows, in addition, the local designation of each well, if the State has closed the file, which year that occurred, the last 5 years verified extractions and the average for those years.

The individual wells of each owner are listed in Table No. 1, showing the extractions from each well for each year in the five-year base period ending in 1963, the base period average, and the extractions for the years 2008-2012.

Table No. 2 summarizes, by owner, the total annual extractions for the base period and base period average, together with the annual extractions years 2008-2012 and that 5 year period. The total annual extractions for 2012 are 62,294 acre feet.

CHAPTER II

PLAINTIFFS EXTRACTIONS FROM THE SAN BERNARDINO BASIN AREA FOR CALENDAR YEARS 1959-1963 AND 2008-2012 AND DISTRIBUTION BY SERVICE AREA

Paragraph XVI of the Judgment states:

"The provisions of Paragraph 3 and 5 through 12 of this Judgment shall be in effect from and after January 1, 1971; and remaining provisions are in effect immediately."

Thus the annual accounting provisions which relate to extractions from the San Bernardino Basin Area by Plaintiffs were not effective until January 1, 1971.

Table No. 1 and 1A of Chapter I shows the extractions from individual wells owned by each Plaintiff for the five calendar year period ending with 1963, the annual average for said five-year period, and the extractions for the calendar years 2008 through 2012 and the annual average for that period. Table No. 2 described in Chapter I summarizes the total annual extractions for each Plaintiff during the five-year period 1959 through 1963, the annual average for the five-year period, and the 2008 through 2012 extractions and the annual average.

Table No. 3 shows total annual extractions and its distribution.

To facilitate the comparison of the total annual extractions as well as the portions thereof delivered within the San Bernardino Basin Area, the Colton Basin and Riverside Basin within San Bernardino County, and to areas outside San Bernardino Valley, four additional tables have been prepared which summarize the total annual extractions from the San Bernardino Basin Area for the period 1959 through 1963 and 1971 through the current year for each Plaintiff, as well as the portions thereof delivered to various service areas described above.

Table No. 4 lists the Total Extractions from the San Bernardino Basin Area for each Plaintiff annually for the period 1959 through 1963 and the five-year average and calendar years 1971 through the current year.

Similar listings were made for the same period which shows the deliveries within the San Bernardino Basin Area, the deliveries to Colton and Riverside Basins within San Bernardino County, and the deliveries to areas outside San Bernardino Valley. These listings are shown on Tables No. 5, 6, and 7 respectively.

ERRATA

Volume 1A, Bunker Hill Basin
Plaintiffs

During the 2012 Verification, July 2013, the following changes were made to the report.

No changes were made

During the 2011 Verification, July 2012, the following changes were made to the report.

The following 2 wells were **closed** during the year

3601219, Riverside City of, Raub 2, 01S/04W-23C02S, noted abandoned on 2011 filing
3601239, Riverside City of, Raub 3, 01S/04W-14P06S, noted abandoned on 2011 filing

During the 2010 Verification, July 2011, the following corrections were made to the report.

The following 2 new wells were **added** to the files this year

3603950, Meeks & Daley Mutual Water Company, Sperry Well, 01S/04W-21L05S. replaces #36 well which was abandoned.
3603951, Meeks & Daley Water Company, Raub #7 Lease, 01S/04W-23C06S, same as Riverside 3603929.

During the 2009 verification, November 2010, the following corrections were made to the report.

The following 3 new wells were **added** to the files this year

3603931, University of California Riverside, Cooley H Lease, 01S/04W-11D02S,
same well as 3601228 and 3603911
3603939, Meeks & Daley, Garner 6 Lease, 01S/04W-02P09S
same as City of Riverside 3603254
3603940, Meeks & Daley, Garner 7 Lease, 01S/04W-02Q11S
same as City of Riverside 3302794

The following **corrections or additions** were made during the year

3603930, City of Riverside, Raub #7, 01S/04W-23C06S full sw#
received from DWR 02/22/10

The following **back-filings/corrected filing** were made during the year

3602423, Riverside - Gage Canal, #6 domestic, corrected
filings from new pump test (with substantial drop in
water level - way off pump curve)
2008 corrected from 16 AF to 3 AF, -13 AF
2007 corrected from 27 AF to 5 AF, -23 AF
2006 corrected from 31 AF to 6 AF, -25 AF

3302794, City of Riverside, Garner 7, 01S/04W-02Q11S was
re-assigned to 3603948. Well was mis-assigned a
Riverside County "33" recordation number in 1996

During the 2009 verification (November 2010) the following changes or corrections were made to the report.

The following new well was **added** to the files this year

3603947, San Bernardino County – Arrowhead Regional Medical Center (ARMC), Nitrate Well, 01S/05W-24H02S, back filed

2000	210 AF
2001	210 AF
2002	210 AF
2003	210 AF
2004	210 AF
2005	210 AF

0000303, Carson, , 01S05W-35B, lost its 1959 Base Period **verified** production of 50 AF between the 1996 and 1997 report – added this water back.

During the 2008 verification (October 2009) the following changes or corrections were made to the report.

The following 1 well was re-opened during the year

3601422, Roquet Harry V, 1 House, 02S/04W-06Q

The following corrections or additions were made during the year

3601706, Green Acres Memorial Park, 8th St, 01S/05W-34L02S, verified correction from 133 af to 47 af, -86 af for 2007

3603738, Riverside Highland Water Company, RN#6, corrected SW# from 02S/05W-05F03S to 02S/04W-05F03S

3603651, Corridor Land Company, South Well – Holly, corrected SW# from 02S/05W-05H to 02S/05W-02H

The following backfilings were made during the year

3601422, Roquet Harry V, 1 House, 02S/04W-06Q, backfiled 115 AF for the period 1999-2007.

3603909, Cal Portland #9, 01S/04W-30A, backfiled 9 AF for 2007

During the 2007 verification (October 2008) the following changes or corrections were made to the report.

Two new non-filers were identified during 2008 field investigations

0000310, Woodland Farms, Ward Duck #2

0000311, Milestone Ranch, 10" sub (actually two wells)

California Portland reactivated an older well which was never filed on, Well #9 which is used to irrigate property boundary landscaping.

During the 2006 verification (March 2008) the following changes or corrections were made to the report.

Starting in 1997, Table 4 was corrected to account that water production from 3600535-, Jurupa #3 well was no longer exported but was used as overlying land use (on-site dust control)

During the 2005 verification (May 2007) no changes or corrections were made to the report.

During the 2004 verification (June 2006) the following changes or corrections were made to the report.

3601892, name change from Beckett to Roger Aguinaga Co., Inc

During the 2003 verification (May 2005) the following changes or corrections were made to the report.

Riverside Canal Power Company replaces Thermo EcoTek as owner for 3601009, 3601001, 3601020, and 3601023 effective in 2000.

During the 2002 verification (June 2004) the following changes or corrections were made to the report.

The following backfilings were made during the year
3603738, Riverside Highland Water Company, RN #6, 2S4W05F03S,
51 AF for 2001

3603759, California Portland Cement, Well #8, 1S4W30A, 51 AF
for 2001

Both wells were located for the first time during the 2002 data collection.

During the 2001 verification (May 2003) no changes or corrections were made to the report.

During the 2000 verification (May 2002) no changes or corrections were made to the report.

During the 1999 verification (June 2001) no changes or corrections were made to the report.

During the 1998 verification (June 2000) the following changes and corrections were made to the report.

Major corrections were made to the RIX Over-Extraction (0000306) values. Conversion from MG to AF error was corrected.

Corridor Land Company Well 3604004 "Riverbottom" was deleted from our records as a duplicate filing of 3604005 "Holly". This dummy recordation number was replaced by 3603651.

During the 1997 verification (June 1999) no changes or corrections were made to the report.

During the 1996 verification (June 1998) the following changes and corrections were made to the report.

Colton Well #24 was reassigned from the Rialto Colton Basin to the Riverside North Basin. 169 AF increase for 1995

Kleckler (0000019) production was not entered into the computer during 1995 verification. Increase of 45 AF for 1995.

During the 1995 verification (June 1997) no changes or corrections were made to the report.

During the 1994 verification (June 1996) no changes or corrections were made to the report.

During the 1993 verification (May 1995) the following changes and corrections were made to the report:

Service Rock (Owl Resources, 3600910, 1S5W35G02S) production for 1992 was adjusted from 54 AF to 12 AF (-42AF) using power records and a back calculated KWH/AF.

During the 1991 verification (May 1993) the following changes and corrections were made to the report:

Holliday Trucking (3603261, 1S5W25M04S) Colton #2 well was added to the program.

During the 1990 verification (June 1992) the following changes and corrections were made to the report:

" " (blanks) and "FC" production amounts that were shown in the 1989 report were replaced by zero, "0", for Roquet (3601422, 1423, 1424) and Madison (3601722, 2114).

During the 1989 verification (June 1991) the following changes and corrections were made to the report:

Backfiled late correction for Owl Service Rock (3600910). Corrected from 5 AF to 56 AF (net 51 AF increase). Well has been re-equipped.

Table No. 4 for 1988 figure for C of R has been corrected

During the 1988 verification (June 1990) the following changes and corrections were made to the report:

Ward Duck Company (0000012) is now known as Woodland Farms.

City of Colton has taken over James Sullivan Mutual Water Co. I did not get an official name change for 3602357.

Inter-County Water was taken over by West San Bernardino County Water District in March of 1987 and a system intertie was installed. They will abandoned the well (3301347) shortly. Presently this makes WSBCWD an exporter from the upper basin.







Lopez bought the Seinturier Well (3602028) from California Portland Cement Co.

Minter, Beverly bought Elmer Dunn Ranch (0000008).

Holiday Sand and Gravel (3600627) back filing on 40 AF for CY 1987.

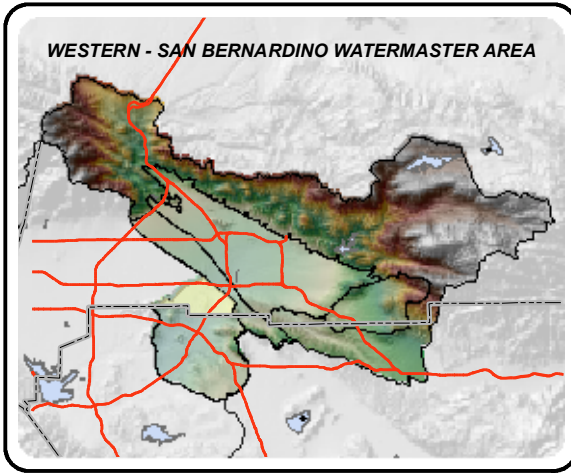
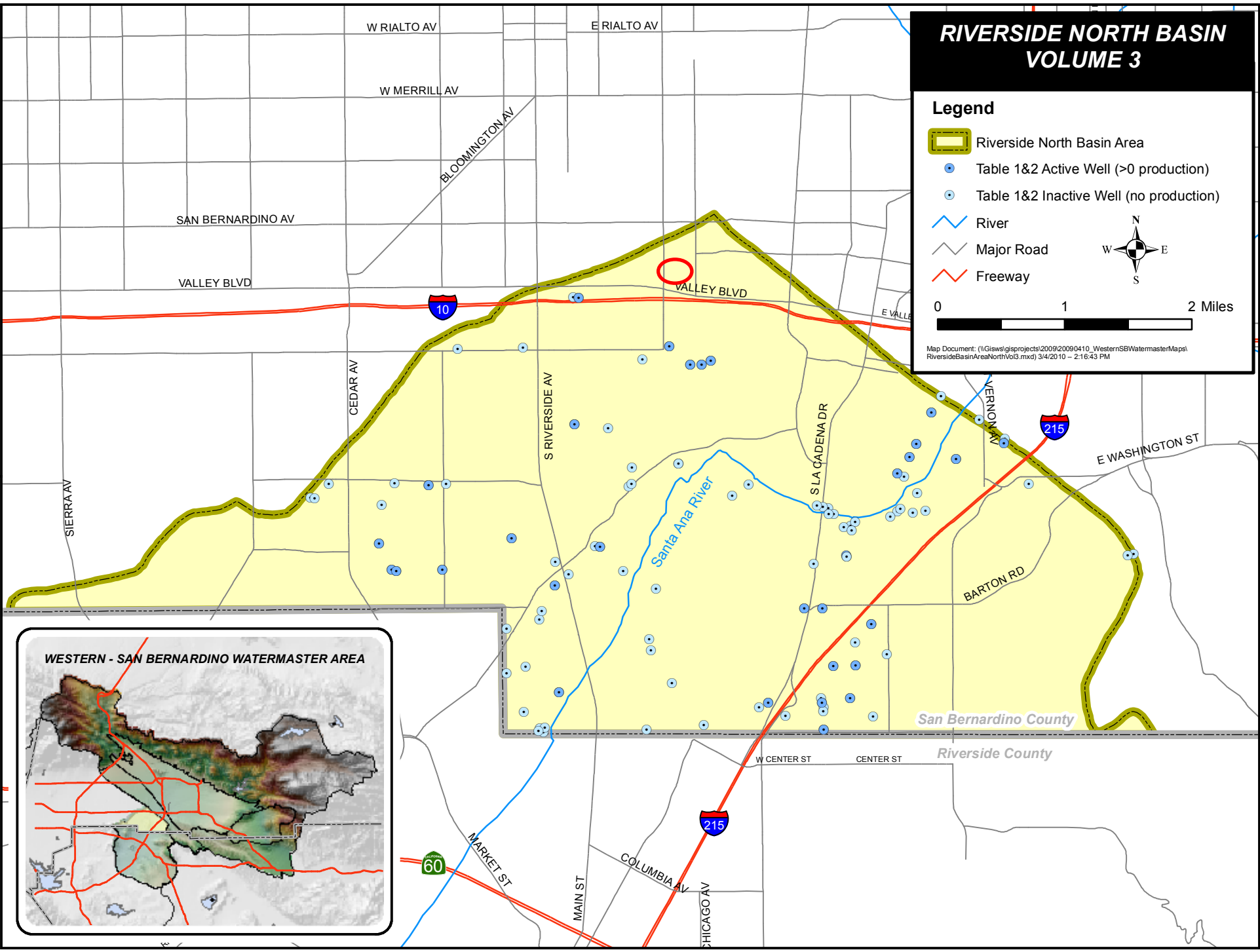
RIVERSIDE NORTH BASIN VOLUME 3

Legend

-  Riverside North Basin Area
-  Table 1&2 Active Well (>0 production)
-  Table 1&2 Inactive Well (no production)
-  River
-  Major Road
-  Freeway

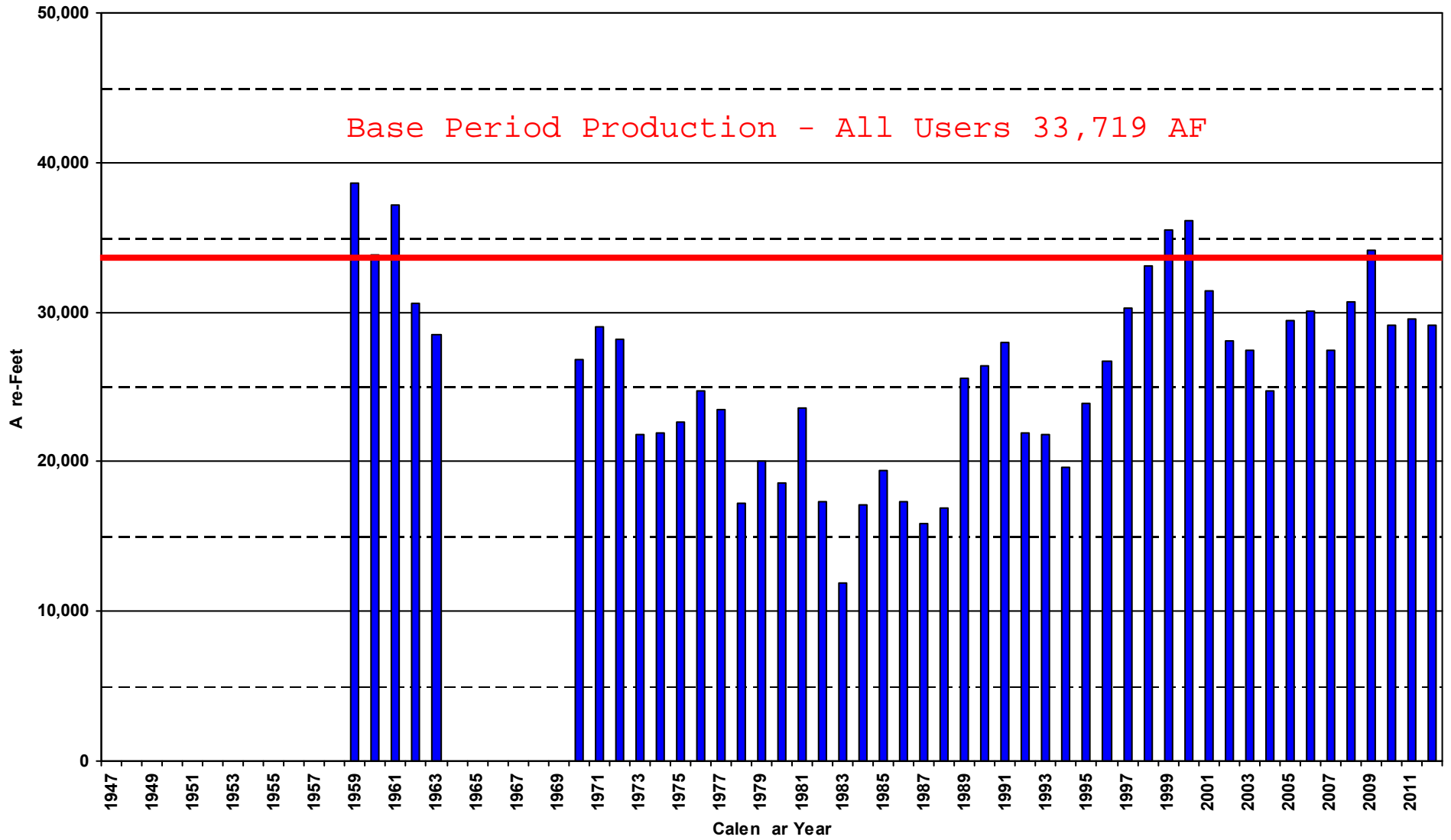


Map Document: (\\GIS\gis\projects\2009\20090410_WesternSBWatermasterMaps\RiversideBasinAreaNorthVol3.mxd) 3/4/2010 - 2:16:43 PM



WESTERN - SAN BERNARDINO WATERMASTER

RIVERSIDE NORTH BASIN



RIVERSIDE BASIN AREA
IN SAN BERNARDINO COUNTY
CROSS INDEX BY OWNER

**WESTERN - SAN BERNARDINO WATERMASTER
VERIFIED PRODUCTION DATA
CROSS INDEX BY OWNER
RIVERSIDE NORTH BASIN**

OWNER	WELL TYPE	RECRDTN NUMBER	STATE WELL NUMBER	LOCAL DESIGNATION	YEAR CLOSED	-----CALENDAR YEAR EXTRACTATIONS-----					
						2008	2009	2010	2011	2012	AVG
AGUA MANSA PROPERTIES, INC	W	3600535-	01S/05W-36C11S	3		27	29	29	28	27	28
AGUA MANSA PROPERTIES, INC	W	3601961	01S/05W-25P	AMRCH 1	1974	0	0	0	0	0	0
AGUINAGA, ROGER	W	3601892	01S/05W-36F		2007	0	0	0	0	0	0
ALLEE RANCH	W	3601891	01S/05W-36F		1977	0	0	0	0	0	0
ASPHALT RECYCLING	W	3603918	01S/05W-36M	SMALL		4	4	4	4	4	4
BRADFORD, IVAN	W	3602697	02S/05W-01P03S		1978	0	0	0	0	0	0
BRADVICA, LOUIS	W	3600972	02S/05W-02Q	RNCH 1	1974	0	0	0	0	0	0
CALIFORNIA PORTLAND CEMENT COMPANY	W	0000302	01S/05W-25P	MILLER HONEY	1999	0	0	0	0	0	0
CALIFORNIA PORTLAND CEMENT COMPANY	W	3601425	01S/05W-25A03S	CPC #6		643	755	327	294	330	470
CALIFORNIA PORTLAND CEMENT COMPANY	W	3601426	01S/04W-30D06S	CPC #5		1,088	1,329	1,198	777	1,113	1,101
CALIFORNIA PORTLAND CEMENT COMPANY	W	3601427	01S/05W-25A02S	CPC #7		51	39	8	13	8	24
CALIFORNIA PORTLAND CEMENT COMPANY	W	3603759	01S/04W-30B01S	WELL #8		2,001	1,870	1,857	1,671	0	1,480
CALIFORNIA PORTLAND CEMENT COMPANY	W	3603909	01S/04W-30A	#9		6	9	1	1	0	3
CANALE CATERING	W	3602233	01S/05W-35J		1964	0	0	0	0	0	0
CARSON, K.	W	0000303	01S/05W-35B	-	1999	0	0	0	0	0	0
COLTON, CITY OF	W	3602357	01S/04W-34L	6610 JAMES SULLIVAN		0	0	0	0	0	0
COLTON, CITY OF	W	3602358	01S/04W-34L	7418 J SULLIVAN		0	0	0	0	0	0
COLTON, CITY OF	W	3603598	01S/04W-18N03S	#24		1,070	1,522	1,375	1,820	1,672	1,492
COLTON, CITY OF	W	3603957	01S/04W-29G01S	#30					0	0	0
COLTON, CITY OF	W	3603958	01S/04W-29G02S	#31					0	0	0
CORRIDOR LAND COMPANY	W	3600910	01S/05W-35G02S	1, AGUA MANSA	2005	0	0	0	0	0	0
CORRIDOR LAND COMPANY	W	3601717	01S/05W-35R	DOUBLE D RANCH	2007	0	0	0	0	0	0
CORRIDOR LAND COMPANY	W	3603651	02S/05W-02H	SOUTH WELL, HOLLY	2000	0	0	0	0	0	0
CORRIDOR LAND COMPANY	W	3603652	02S/05W-01E	SOUTH #1 RIVERBOTTO	2007	0	0	0	0	0	0
COUNTRY CLUB STORAGE	W	3602326	01S/04W-30R		1981	0	0	0	0	0	0
DAGGETT, FOREST N.	W	3601100	01S/04W-31C	BARN 1	1972	0	0	0	0	0	0
DAGGETT, FOREST N.	W	3601101	01S/04W-31C	RIVER 2	1972	0	0	0	0	0	0
EL RIVINO COUNTRY CLUB	W	3601707	01S/05W-34J01S	CACTUS		560	340	98	0	0	200
ELSINORE VALLEY M.W.D.	W	3601509	02S/04W-06A03S	PALM AVE		2,043	1,010	0	8	0	612
EMPIRE WATER	W	3600829	01S/04W-32G02S	1	1974	0	0	0	0	0	0
EMPIRE WATER	W	3600830	01S/04W-32G04S	2	1974	0	0	0	0	0	0
EMPIRE WATER	W	3600831	01S/04W-32H01S	4	1974	0	0	0	0	0	0
EMPIRE WATER	W	3600832	01S/04W-32B01S	350" #5		0	0	10	0	0	2
EMPIRE WATER	W	3600833	01S/04W-32G01S	6	1974	0	0	0	0	0	0
EMPIRE WATER	W	3601953	01S/04W-32B02S	350" #7		0	0	0	0	0	0
FIRESTONE GROUP LTD	W	3600413	01S/05W-34B01S		1981	0	0	0	0	0	0
FISHER, CHARLOTTE	W	0000304	01S/05W-36B	OLD DUNN		0	1	1	1	1	1

**WESTERN - SAN BERNARDINO WATERMASTER
VERIFIED PRODUCTION DATA
CROSS INDEX BY OWNER
RIVERSIDE NORTH BASIN**

OWNER	WELL TYPE	RECRDTN NUMBER	STATE WELL NUMBER	LOCAL DESIGNATION	YEAR CLOSED	-----CALENDAR YEAR EXTRACTATIONS-----						AVG
						2008	2009	2010	2011	2012		
GENERAL AMERICAN TRANSPORTATION CORP (W	3601124	01S/05W-24R01S	1 SOUTH		5	5	6	4	5	5	
GRAND TERRACE, CITY OF	W	3601970	02S/04W-05M01S	PICO #64		0	0	0	0	0	0	
GREEN ACRES	W	3601110	01S/05W-34A	1		98	33	1	0	0	26	
GREEN ACRES MEMORIAL PARK ASS'N	W	3600873	01S/05W-34K02S	NO 57, W'LY		98	98	0	0	0	39	
GREEN ACRES MEMORIAL PARK ASS'N	W	3601706	01S/05W-34L02S	8TH ST		133	133	146	90	90	118	
GREEN ACRES MEMORIAL PARK ASS'N	W	3601721	01S/05W-34K	56, E'LY		102	92	140	90	90	103	
HAMADA BROS	W	3600507	01S/05W-35D01S	1	1991	0	0	0	0	0	0	
HOLLIDAY TRUCKING	W	3600627	01S/05W-25M	1 COLTON		53	47	48	44	48	48	
HOLLIDAY TRUCKING	W	3603261	01S/05W-25M04S	COLTON #2		52	54	54	52	53	53	
HOLTER RANCH	W	0000305	01S/05W-36N	HENDRICKS	1998	0	0	0	0	0	0	
HOWELL, ORUS	W	3600097	02S/05W-01Q		1991	0	0	0	0	0	0	
HUNGERFORD, FRANK B.	W	3601345	02S/04W-05E	JOHNSON	1960	0	0	0	0	0	0	
INTER COUNTY WATER COMPANY	W	3301347	02S/05W-02C	1	1981	0	0	0	0	0	0	
JOHNSON, DOROTHY	W	3600820	02S/04W-05P	1	1965	0	0	0	0	0	0	
JUMAL WATER COMPANY	W	3600537	02S/04W-05F02S		1985	0	0	0	0	0	0	
JURUPA WATER COMPANY	W	3600535	01S/05W-36C09S	NO 1	1978	0	0	0	0	0	0	
JURUPA WATER COMPANY	W	3600536	01S/05W-36C10S	1 AND HALF	1974	0	0	0	0	0	0	
KLECKLER, DON	W	0000309	01S/05W-36M	15 HP	2007	0	0	0	0	0	0	
LA SIERRA WATER COMPANY	W	3601539	01S/04W-32E01S	1	1962	0	0	0	0	0	0	
LA SIERRA WATER COMPANY	W	3601540	01S/04W-32E03S	2	1974	0	0	0	0	0	0	
LA SIERRA WATER COMPANY	W	3601541	01S/04W-32E06S	4	1974	0	0	0	0	0	0	
LA SIERRA WATER COMPANY	W	3601542	01S/04W-32E05S	5	1974	0	0	0	0	0	0	
LA SIERRA WATER COMPANY	W	3601543	01S/04W-32E02S	6	1974	0	0	0	0	0	0	
LA SIERRA WATER COMPANY	W	3601544	01S/04W-32E07S	7	2006	0	0	0	0	0	0	
LA SIERRA WATER COMPANY	W	3601545	01S/04W-32E11S	8	2006	0	0	0	0	0	0	
LA SIERRA WATER COMPANY	W	3601546	01S/04W-32E09S	10	1992	0	0	0	0	0	0	
LA SIERRA WATER COMPANY	W	3601547	01S/04W-32E10S	9	1974	0	0	0	0	0	0	
LA SIERRA WATER COMPANY	W	3691486	01S/04W-29Q03S	FLUME 4	1984	0	0	0	0	0	0	
LA SIERRA WATER COMPANY	W	3692486	01S/04W-29Q04S	FLUME 6	1982	0	0	0	0	0	0	
MADISON, ERIN	W	3601722	02S/05W-02A	58-1	1989	0	0	0	0	0	0	
MADISON, ERIN	W	3602114	02S/05W-02G	63-1	1989	0	0	0	0	0	0	
MASON,	W	0000301	02S/05W-02R	MASON	1997	0	0	0	0	0	0	
MCDANIEL & SON DAIRY	W	0000307	01S/04W-30P01S	DAIRY		1	1	1	1	1	1	
MERRYFIELD WATER COMPANY	W	3600962	02S/04W-06A01S	1		1	0	1	2	2	1	
MILESTONE RANCH	W	0000311	02S/05W-02J	10" WELL		15	15	15	15	15	15	
MILESTONE RANCH	W	3601996	02S/05W-02J	KLEIN /SAND RIVER #1		15	15	15	15	15	15	
RANCHO DE SANTA FE	W	3601088	01S/05W-33A01S	SANTA FE ELECTRIC A1	1974	0	0	0	0	0	0	

**WESTERN - SAN BERNARDINO WATERMASTER
VERIFIED PRODUCTION DATA
CROSS INDEX BY OWNER
RIVERSIDE NORTH BASIN**

OWNER	WELL TYPE	RECRDTN NUMBER	STATE WELL NUMBER	LOCAL DESIGNATION	YEAR CLOSED	-----CALENDAR YEAR EXTRACTIIONS-----					
						2008	2009	2010	2011	2012	AVG
RANCHO DE SANTA FE	W	3602222	01S/05W-33A02S	GAS A-2	1989	0	0	0	0	0	0
RIALTO, CITY OF	W	3601680	01S/05W-25L02S	DISPOSAL	1989	0	0	0	0	0	0
RIVERSIDE CANAL POWER CO.	W	3601009	02S/04W-06J01S	RIV CANAL 60		0	0	0	0	0	0
RIVERSIDE CANAL POWER CO.	W	3601011	02S/04W-06R04S	RIV CANAL 61		1	1	1	1	1	1
RIVERSIDE CANAL POWER CO.	W	3601020	02S/04W-06R05S	RIV CANAL 62/CE #3		0	0	0	0	0	0
RIVERSIDE CANAL POWER CO.	W	3601023	02S/04W-06R06S	RIV CANAL 63/CE #4		0	0	0	0	0	0
RIVERSIDE CEMENT COMPANY	W	3600874	02S/05W-02A	58-1	1974	0	0	0	0	0	0
RIVERSIDE CEMENT COMPANY	W	3600883	02S/05W-02G02S	WRIGHT	1962	0	0	0	0	0	0
RIVERSIDE CEMENT COMPANY	W	3601782	02S/05W-02L02S		1964	0	0	0	0	0	0
RIVERSIDE HIGHLAND WATER CO	W	3601524	01S/04W-28L01S	3	1964	0	0	0	0	0	0
RIVERSIDE HIGHLAND WATER CO	W	3601526	02S/04W-06R01S	RN #7		154	546	1,253	1,129	699	756
RIVERSIDE HIGHLAND WATER CO	W	3601531	01S/04W-33B05S	RN #16	1964	0	0	0	0	0	0
RIVERSIDE HIGHLAND WATER CO	W	3601532	01S/04W-28N05S	RN #17		40	48	71	8	18	37
RIVERSIDE HIGHLAND WATER CO	W	3601534	01S/04W-28L02S	RN #20		95	0	1	0	0	19
RIVERSIDE HIGHLAND WATER CO	W	3601789	01S/04W-32M01S	LV #1	1992	0	0	0	0	0	0
RIVERSIDE HIGHLAND WATER CO	W	3601790	01S/04W-32M02S	LV #2	1992	0	0	0	0	0	0
RIVERSIDE HIGHLAND WATER CO	W	3603139	01S/04W-32M04S	LV #3		4	37	25	277	180	105
RIVERSIDE HIGHLAND WATER CO	W	3603738	02S/04W-05F03S	RN #6		1,352	2,075	1,637	1,099	1,461	1,525
RIVERSIDE, CITY OF	D	3301088	01S/05W-36Q	PELISIER		0	0	0	0	0	0
RIVERSIDE, CITY OF	W	3600898	01S/05W-25R02S	NO 6	1978	0	0	0	0	0	0
RIVERSIDE, CITY OF	W	3600898-	01S/05W-25R04S	TWIN BUTTE # 6		0	0	0	0	0	0
RIVERSIDE, CITY OF	W	3601221	02S/05W-01J03S	DOM PELLISI		0	0	0	0	0	0
RIVERSIDE, CITY OF	W	3601223	02S/05W-01G02S	MAIN PELLISI		0	0	0	0	0	0
RIVERSIDE, CITY OF	W	3601235	02S/05W-01G01S	LA LOMA	1974	0	0	0	0	0	0
RIVERSIDE, CITY OF	W	3601236	01S/05W-36L01S	AGUA MANSA		0	0	0	0	0	0
RIVERSIDE, CITY OF	W	3601271	02S/04W-06Q03S	MARCY	1973	0	0	0	0	0	0
RIVERSIDE, CITY OF	W	3601483	01S/04W-29H02S	FLUME 1	1977	0	0	0	0	0	0
RIVERSIDE, CITY OF	W	3601484	01S/04W-29H01S	FLUME 2		954	2,749	1,577	1,667	1,675	1,724
RIVERSIDE, CITY OF	W	3601485	01S/04W-29R01S	FLUME 3		974	2,477	2,671	3,125	2,872	2,424
RIVERSIDE, CITY OF	W	3601486	01S/04W-29Q03S	FLUME 4		934	2,244	2,311	2,697	2,236	2,084
RIVERSIDE, CITY OF	W	3601487	01S/04W-29Q01S	FLUME 5	1977	0	0	0	0	0	0
RIVERSIDE, CITY OF	W	3601488	02S/05W-01Q01S	WILLIAMS	1974	0	0	0	0	0	0
RIVERSIDE, CITY OF	W	3601490	02S/05W-11B	JURUPA 1	1980	0	0	0	0	0	0
RIVERSIDE, CITY OF	W	3601491	02S/05W-02R03S	JURUPA 3	1980	0	0	0	0	0	0
RIVERSIDE, CITY OF	W	3601492	02S/05W-02R02S	JURUPA 4	1980	0	0	0	0	0	0
RIVERSIDE, CITY OF	W	3601493	02S/05W-02R01S	JURUPA 5	1980	0	0	0	0	0	0
RIVERSIDE, CITY OF	W	3602234	02S/05W-02Q07S	JURUPA 6		0	0	0	0	0	0

**WESTERN - SAN BERNARDINO WATERMASTER
VERIFIED PRODUCTION DATA
CROSS INDEX BY OWNER
RIVERSIDE NORTH BASIN**

OWNER	WELL TYPE	RECRDTN NUMBER	STATE WELL NUMBER	LOCAL DESIGNATION	YEAR CLOSED	-----CALENDAR YEAR EXTRACTATIONS-----					
						2008	2009	2010	2011	2012	AVG
RIVERSIDE, CITY OF	W	3602486	01S/04W-29Q04S	FLUME 6		959	735	30	319	393	487
RIVERSIDE, CITY OF	W	3602748	02S/05W-02Q08S	JURUPA 7		987	1,122	978	1,071	1,092	1,050
RIVERSIDE, CITY OF	W	3603117	02S/04W-05E01S	VAN BUREN #1 -E'LY		1,915	2,192	1,898	1,689	1,967	1,932
RIVERSIDE, CITY OF	W	3603118	02S/04W-05E02S	VAN BUREN #2 - W'LY		2,079	2,095	1,580	1,475	1,693	1,784
RIVERSIDE, CITY OF	W	3603961	01S/04W-32F05S	FLUME #7						1,948	390
RIVERSIDE, CITY OF-GAGE CANAL	W	3600783	02S/04W-05C01S	DEBERRY		1,849	1,601	1,074	693	1,304	1,304
ROQUET, HARRY V.	W	3601422	02S/04W-06Q	1 HOUSE		115	185	145	145	35	125
ROQUET, HARRY V.	W	3601423	02S/04W-06N	2 WEST	1991	0	0	0	0	0	0
ROQUET, HARRY V.	D	3601424	02S/04W-06P		1991	0	0	0	0	0	0
ROSDALE WATER COMPANY	W	3600915	01S/04W-31J01S	NEW WELL	1968	0	0	0	0	0	0
SAN BERNARDINO COUNTY - ARROWHEAD REGI	W	3603947	01S/05W-24H02S	NITRATE WELL		0	0	0	93	35	26
SAN BERNARDINO, CITY OF	W	0000306	01S/05W-36F	RIX OVER EXTRACTION		7,883	7,729	8,533	8,094	5,968	7,641
SERVICE ROCK CO	W	3600911	01S/05W-35J	2	1974	0	0	0	0	0	0
STAPAKIS, WILLIAM	W	3601488-	02S/05W-01Q01S	WILLIAMS	1974	0	0	0	0	0	0
VILLELLI ENTERPRISES	W	3601549	01S/04W-28M01S	2	1981	0	0	0	0	0	0
VULCAN - CAL MAT	W	3602028	01S/05W-25B02S	SEINTURIER	1988	0	0	0	0	0	0
WAGONER, JOHN J	W	3600899	02S/04W-05F	DOM 1	1972	0	0	0	0	0	0
WEST VALLEY WATER DIST	W	3600074	01S/05W-23Q01S	#29 / SLOVER & RIVER		0	0	0	0	0	0
WEST VALLEY WATER DIST	W	3601004	01S/05W-23N01S	#19	1973	0	0	0	0	0	0
WEST VALLEY WATER DIST	W	3601434	01S/05W-34D01S	#25 14TH & LINDEN	1981	0	0	0	0	0	0
WEST VALLEY WATER DIST	W	3601683	01S/05W-34B02S	#26 END OF 12TH ST	1981	0	0	0	0	0	0
WEST VALLEY WATER DIST	W	3601763	01S/05W-24M01S	#18 / SLOVER MUTUAL	1981	0	0	0	0	0	0
WEST VALLEY WATER DIST	W	3603669	01S/05W-24M02S	#18A		2,269	938	0	1,073	2,085	1,273
WEST VALLEY WATER DIST	W	3603670	01S/05W-36E03S	#41		0	0	0	0	0	0
WOODLAND FARMS	W	0000308	01S/05W-25R	WARD DUCK		0	0	0	0	0	0
WOODLAND FARMS	W	0000310	01S/05W-25R	WARD DUCK #2		48	5	5	5	1	13
YEAGER, REIDMAN & HORN	W	3603901	02S/05W-02R	MASON WELL #1		0	0	0	0	0	0
TOTALS FOR 138 WELLS						30,678	34,180	29,125	29,590	29,137	30,542

RIVERSIDE BASIN AREA
IN SAN BERNARDINO COUNTY
CROSS INDEX BY STATE WELL NUMBER

**WESTERN - SAN BERNARDINO WATERMASTER
VERIFIED PRODUCTION DATA
CROSS INDEX BY STATE WELL NUMBER
RIVERSIDE NORTH BASIN**

STATE WELL NUMBER	RECRDTN NUMBER	OWNER	WELL TYPE	LOCAL DESIGNATION	YEAR CLOSED	-----CALENDAR YEAR EXTRACTIONS-----					
						2008	2009	2010	2011	2012	AVG
01S/04W-18N03S	3603598	COLTON, CITY OF	W	#24		1,070	1,522	1,375	1,820	1,672	1,492
01S/04W-28L01S	3601524	RIVERSIDE HIGHLAND WATER CO	W	3	1964	0	0	0	0	0	0
01S/04W-28L02S	3601534	RIVERSIDE HIGHLAND WATER CO	W	RN #20		95	0	1	0	0	19
01S/04W-28M01S	3601549	VILLELLI ENTERPRISES	W	2	1981	0	0	0	0	0	0
01S/04W-28N05S	3601532	RIVERSIDE HIGHLAND WATER CO	W	RN #17		40	48	71	8	18	37
01S/04W-29G01S	3603957	COLTON, CITY OF	W	#30					0	0	0
01S/04W-29G02S	3603958	COLTON, CITY OF	W	#31					0	0	0
01S/04W-29H01S	3601484	RIVERSIDE, CITY OF	W	FLUME 2		954	2,749	1,577	1,667	1,675	1,724
01S/04W-29H02S	3601483	RIVERSIDE, CITY OF	W	FLUME 1	1977	0	0	0	0	0	0
01S/04W-29Q01S	3601487	RIVERSIDE, CITY OF	W	FLUME 5	1977	0	0	0	0	0	0
01S/04W-29Q03S	3601486	RIVERSIDE, CITY OF	W	FLUME 4		934	2,244	2,311	2,697	2,236	2,084
01S/04W-29Q03S	3691486	LA SIERRA WATER COMPANY	W	FLUME 4	1984	0	0	0	0	0	0
01S/04W-29Q04S	3602486	RIVERSIDE, CITY OF	W	FLUME 6		959	735	30	319	393	487
01S/04W-29Q04S	3692486	LA SIERRA WATER COMPANY	W	FLUME 6	1982	0	0	0	0	0	0
01S/04W-29R01S	3601485	RIVERSIDE, CITY OF	W	FLUME 3		974	2,477	2,671	3,125	2,872	2,424
01S/04W-30A	3603909	CALIFORNIA PORTLAND CEMENT COMPANY	W	#9		6	9	1	1	0	3
01S/04W-30B01S	3603759	CALIFORNIA PORTLAND CEMENT COMPANY	W	WELL #8		2,001	1,870	1,857	1,671	0	1,480
01S/04W-30D06S	3601426	CALIFORNIA PORTLAND CEMENT COMPANY	W	CPC #5		1,088	1,329	1,198	777	1,113	1,101
01S/04W-30P01S	0000307	MCDANIEL & SON DAIRY	W	DAIRY		1	1	1	1	1	1
01S/04W-30R	3602326	COUNTRY CLUB STORAGE	W		1981	0	0	0	0	0	0
01S/04W-31C	3601100	DAGGETT, FOREST N.	W	BARN 1	1972	0	0	0	0	0	0
01S/04W-31C	3601101	DAGGETT, FOREST N.	W	RIVER 2	1972	0	0	0	0	0	0
01S/04W-31J01S	3600915	ROSEDALE WATER COMPANY	W	NEW WELL	1968	0	0	0	0	0	0
01S/04W-32B01S	3600832	EMPIRE WATER	W	350" #5		0	0	10	0	0	2
01S/04W-32B02S	3601953	EMPIRE WATER	W	350" #7		0	0	0	0	0	0
01S/04W-32E01S	3601539	LA SIERRA WATER COMPANY	W	1	1962	0	0	0	0	0	0
01S/04W-32E02S	3601543	LA SIERRA WATER COMPANY	W	6	1974	0	0	0	0	0	0
01S/04W-32E03S	3601540	LA SIERRA WATER COMPANY	W	2	1974	0	0	0	0	0	0
01S/04W-32E05S	3601542	LA SIERRA WATER COMPANY	W	5	1974	0	0	0	0	0	0
01S/04W-32E06S	3601541	LA SIERRA WATER COMPANY	W	4	1974	0	0	0	0	0	0
01S/04W-32E07S	3601544	LA SIERRA WATER COMPANY	W	7	2006	0	0	0	0	0	0
01S/04W-32E09S	3601546	LA SIERRA WATER COMPANY	W	10	1992	0	0	0	0	0	0
01S/04W-32E10S	3601547	LA SIERRA WATER COMPANY	W	9	1974	0	0	0	0	0	0
01S/04W-32E11S	3601545	LA SIERRA WATER COMPANY	W	8	2006	0	0	0	0	0	0
01S/04W-32F05S	3603961	RIVERSIDE, CITY OF	W	FLUME #7						1,948	390
01S/04W-32G01S	3600833	EMPIRE WATER	W	6	1974	0	0	0	0	0	0
01S/04W-32G02S	3600829	EMPIRE WATER	W	1	1974	0	0	0	0	0	0

**WESTERN - SAN BERNARDINO WATERMASTER
VERIFIED PRODUCTION DATA
CROSS INDEX BY STATE WELL NUMBER
RIVERSIDE NORTH BASIN**

STATE WELL NUMBER	RECRDTN NUMBER	OWNER	WELL TYPE	LOCAL DESIGNATION	YEAR CLOSED	-----CALENDAR YEAR EXTRACTIONS-----					
						2008	2009	2010	2011	2012	AVG
01S/04W-32G04S	3600830	EMPIRE WATER	W	2	1974	0	0	0	0	0	0
01S/04W-32H01S	3600831	EMPIRE WATER	W	4	1974	0	0	0	0	0	0
01S/04W-32M01S	3601789	RIVERSIDE HIGHLAND WATER CO	W	LV #1	1992	0	0	0	0	0	0
01S/04W-32M02S	3601790	RIVERSIDE HIGHLAND WATER CO	W	LV #2	1992	0	0	0	0	0	0
01S/04W-32M04S	3603139	RIVERSIDE HIGHLAND WATER CO	W	LV #3		4	37	25	277	180	105
01S/04W-33B05S	3601531	RIVERSIDE HIGHLAND WATER CO	W	RN #16	1964	0	0	0	0	0	0
01S/04W-34L	3602357	COLTON, CITY OF	W	6610 JAMES SULLIVAN		0	0	0	0	0	0
01S/04W-34L	3602358	COLTON, CITY OF	W	7418 J SULLIVAN		0	0	0	0	0	0
01S/05W-23N01S	3601004	WEST VALLEY WATER DIST	W	#19	1973	0	0	0	0	0	0
01S/05W-23Q01S	3600074	WEST VALLEY WATER DIST	W	#29 / SLOVER & RIVER		0	0	0	0	0	0
01S/05W-24H02S	3603947	SAN BERNARDINO COUNTY - ARROWHEAD REGI	W	NITRATE WELL		0	0	0	93	35	26
01S/05W-24M01S	3601763	WEST VALLEY WATER DIST	W	#18 / SLOVER MUTUAL	1981	0	0	0	0	0	0
01S/05W-24M02S	3603669	WEST VALLEY WATER DIST	W	#18A		2,269	938	0	1,073	2,085	1,273
01S/05W-24R01S	3601124	GENERAL AMERICAN TRANSPORTATION CORP (W	1 SOUTH		5	5	6	4	5	5
01S/05W-25A02S	3601427	CALIFORNIA PORTLAND CEMENT COMPANY	W	CPC #7		51	39	8	13	8	24
01S/05W-25A03S	3601425	CALIFORNIA PORTLAND CEMENT COMPANY	W	CPC #6		643	755	327	294	330	470
01S/05W-25B02S	3602028	VULCAN - CAL MAT	W	SEINTURIER	1988	0	0	0	0	0	0
01S/05W-25L02S	3601680	RIALTO, CITY OF	W	DISPOSAL	1989	0	0	0	0	0	0
01S/05W-25M	3600627	HOLLIDAY TRUCKING	W	1 COLTON		53	47	48	44	48	48
01S/05W-25M04S	3603261	HOLLIDAY TRUCKING	W	COLTON #2		52	54	54	52	53	53
01S/05W-25P	0000302	CALIFORNIA PORTLAND CEMENT COMPANY	W	MILLER HONEY	1999	0	0	0	0	0	0
01S/05W-25P	3601961	AGUA MANSA PROPERTIES, INC	W	AMRCH 1	1974	0	0	0	0	0	0
01S/05W-25R	0000308	WOODLAND FARMS	W	WARD DUCK		0	0	0	0	0	0
01S/05W-25R	0000310	WOODLAND FARMS	W	WARD DUCK #2		48	5	5	5	1	13
01S/05W-25R02S	3600898	RIVERSIDE, CITY OF	W	NO 6	1978	0	0	0	0	0	0
01S/05W-25R04S	3600898-	RIVERSIDE, CITY OF	W	TWIN BUTTE # 6		0	0	0	0	0	0
01S/05W-33A01S	3601088	RANCHO DE SANTA FE	W	SANTA FE ELECTRIC A1	1974	0	0	0	0	0	0
01S/05W-33A02S	3602222	RANCHO DE SANTA FE	W	GAS A-2	1989	0	0	0	0	0	0
01S/05W-34A	3601110	GREEN ACRES	W	1		98	33	1	0	0	26
01S/05W-34B01S	3600413	FIRESTONE GROUP LTD	W		1981	0	0	0	0	0	0
01S/05W-34B02S	3601683	WEST VALLEY WATER DIST	W	#26 END OF 12TH ST	1981	0	0	0	0	0	0
01S/05W-34D01S	3601434	WEST VALLEY WATER DIST	W	#25 14TH & LINDEN	1981	0	0	0	0	0	0
01S/05W-34J01S	3601707	EL RIVINO COUNTRY CLUB	W	CACTUS		560	340	98	0	0	200
01S/05W-34K	3601721	GREEN ACRES MEMORIAL PARK ASS'N	W	56, E'LY		102	92	140	90	90	103
01S/05W-34K02S	3600873	GREEN ACRES MEMORIAL PARK ASS'N	W	NO 57, W'LY		98	98	0	0	0	39
01S/05W-34L02S	3601706	GREEN ACRES MEMORIAL PARK ASS'N	W	8TH ST		133	133	146	90	90	118
01S/05W-35B	0000303	CARSON, K.	W	-	1999	0	0	0	0	0	0

**WESTERN - SAN BERNARDINO WATERMASTER
VERIFIED PRODUCTION DATA
CROSS INDEX BY STATE WELL NUMBER
RIVERSIDE NORTH BASIN**

STATE WELL NUMBER	RECRDTN NUMBER	OWNER	WELL TYPE	LOCAL DESIGNATION	YEAR CLOSED	-----CALENDAR YEAR EXTRACTIONS-----					
						2008	2009	2010	2011	2012	AVG
01S/05W-35D01S	3600507	HAMADA BROS	W	1	1991	0	0	0	0	0	0
01S/05W-35G02S	3600910	CORRIDOR LAND COMPANY	W	1, AGUA MANSA	2005	0	0	0	0	0	0
01S/05W-35J	3600911	SERVICE ROCK CO	W	2	1974	0	0	0	0	0	0
01S/05W-35J	3602233	CANALE CATERING	W		1964	0	0	0	0	0	0
01S/05W-35R	3601717	CORRIDOR LAND COMPANY	W	DOUBLE D RANCH	2007	0	0	0	0	0	0
01S/05W-36B	0000304	FISHER, CHARLOTTE	W	OLD DUNN		0	1	1	1	1	1
01S/05W-36C09S	3600535	JURUPA WATER COMPANY	W	NO 1	1978	0	0	0	0	0	0
01S/05W-36C10S	3600536	JURUPA WATER COMPANY	W	1 AND HALF	1974	0	0	0	0	0	0
01S/05W-36C11S	3600535-	AGUA MANSA PROPERTIES, INC	W	3		27	29	29	28	27	28
01S/05W-36E03S	3603670	WEST VALLEY WATER DIST	W	#41		0	0	0	0	0	0
01S/05W-36F	0000306	SAN BERNARDINO, CITY OF	W	RIX OVER EXTRACTIONS		7,883	7,729	8,533	8,094	5,968	7,641
01S/05W-36F	3601891	ALLEE RANCH	W		1977	0	0	0	0	0	0
01S/05W-36F	3601892	AGUINAGA, ROGER	W		2007	0	0	0	0	0	0
01S/05W-36L01S	3601236	RIVERSIDE, CITY OF	W	AGUA MANSA		0	0	0	0	0	0
01S/05W-36M	0000309	KLECKLER, DON	W	15 HP	2007	0	0	0	0	0	0
01S/05W-36M	3603918	ASPHALT RECYCLING	W	SMALL		4	4	4	4	4	4
01S/05W-36N	0000305	HOLTER RANCH	W	HENDRICKS	1998	0	0	0	0	0	0
01S/05W-36Q	3301088	RIVERSIDE, CITY OF	D	PELISIER		0	0	0	0	0	0
02S/04W-05C01S	3600783	RIVERSIDE, CITY OF-GAGE CANAL	W	DEBERRY		1,849	1,601	1,074	693	1,304	1,304
02S/04W-05E	3601345	HUNGERFORD, FRANK B.	W	JOHNSON	1960	0	0	0	0	0	0
02S/04W-05E01S	3603117	RIVERSIDE, CITY OF	W	VAN BUREN #1 -E'LY		1,915	2,192	1,898	1,689	1,967	1,932
02S/04W-05E02S	3603118	RIVERSIDE, CITY OF	W	VAN BUREN #2 - W'LY		2,079	2,095	1,580	1,475	1,693	1,784
02S/04W-05F	3600899	WAGONER, JOHN J	W	DOM 1	1972	0	0	0	0	0	0
02S/04W-05F02S	3600537	JUMAL WATER COMPANY	W		1985	0	0	0	0	0	0
02S/04W-05F03S	3603738	RIVERSIDE HIGHLAND WATER CO	W	RN #6		1,352	2,075	1,637	1,099	1,461	1,525
02S/04W-05M01S	3601970	GRAND TERRACE, CITY OF	W	PICO #64		0	0	0	0	0	0
02S/04W-05P	3600820	JOHNSON, DOROTHY	W	1	1965	0	0	0	0	0	0
02S/04W-06A01S	3600962	MERRYFIELD WATER COMPANY	W	1		1	0	1	2	2	1
02S/04W-06A03S	3601509	ELSINORE VALLEY M.W.D.	W	PALM AVE		2,043	1,010	0	8	0	612
02S/04W-06J01S	3601009	RIVERSIDE CANAL POWER CO.	W	RIV CANAL 60		0	0	0	0	0	0
02S/04W-06N	3601423	ROQUET, HARRY V.	W	2 WEST	1991	0	0	0	0	0	0
02S/04W-06P	3601424	ROQUET, HARRY V.	D		1991	0	0	0	0	0	0
02S/04W-06Q	3601422	ROQUET, HARRY V.	W	1 HOUSE		115	185	145	145	35	125
02S/04W-06Q03S	3601271	RIVERSIDE, CITY OF	W	MARCY	1973	0	0	0	0	0	0
02S/04W-06R01S	3601526	RIVERSIDE HIGHLAND WATER CO	W	RN #7		154	546	1,253	1,129	699	756
02S/04W-06R04S	3601011	RIVERSIDE CANAL POWER CO.	W	RIV CANAL 61		1	1	1	1	1	1
02S/04W-06R05S	3601020	RIVERSIDE CANAL POWER CO.	W	RIV CANAL 62/CE #3		0	0	0	0	0	0

**WESTERN - SAN BERNARDINO WATERMASTER
 VERIFIED PRODUCTION DATA
 CROSS INDEX BY STATE WELL NUMBER
 RIVERSIDE NORTH BASIN**

STATE WELL NUMBER	RECRDTN NUMBER	OWNER	WELL TYPE	LOCAL DESIGNATION	YEAR CLOSED	-----CALENDAR YEAR EXTRACTIONS-----					
						2008	2009	2010	2011	2012	AVG
02S/04W-06R06S	3601023	RIVERSIDE CANAL POWER CO.	W	RIV CANAL 63/CE #4		0	0	0	0	0	0
02S/05W-01E	3603652	CORRIDOR LAND COMPANY	W	SOUTH #1 RIVERBOTTO	2007	0	0	0	0	0	0
02S/05W-01G01S	3601235	RIVERSIDE, CITY OF	W	LA LOMA	1974	0	0	0	0	0	0
02S/05W-01G02S	3601223	RIVERSIDE, CITY OF	W	MAIN PELLISI		0	0	0	0	0	0
02S/05W-01J03S	3601221	RIVERSIDE, CITY OF	W	DOM PELLISI		0	0	0	0	0	0
02S/05W-01P03S	3602697	BRADFORD, IVAN	W		1978	0	0	0	0	0	0
02S/05W-01Q	3600097	HOWELL, ORUS	W		1991	0	0	0	0	0	0
02S/05W-01Q01S	3601488	RIVERSIDE, CITY OF	W	WILLIAMS	1974	0	0	0	0	0	0
02S/05W-01Q01S	3601488-	STAPAKIS, WILLIAM	W	WILLIAMS	1974	0	0	0	0	0	0
02S/05W-02A	3600874	RIVERSIDE CEMENT COMPANY	W	58-1	1974	0	0	0	0	0	0
02S/05W-02A	3601722	MADISON, ERIN	W	58-1	1989	0	0	0	0	0	0
02S/05W-02C	3301347	INTER COUNTY WATER COMPANY	W	1	1981	0	0	0	0	0	0
02S/05W-02G	3602114	MADISON, ERIN	W	63-1	1989	0	0	0	0	0	0
02S/05W-02G02S	3600883	RIVERSIDE CEMENT COMPANY	W	WRIGHT	1962	0	0	0	0	0	0
02S/05W-02H	3603651	CORRIDOR LAND COMPANY	W	SOUTH WELL, HOLLY	2000	0	0	0	0	0	0
02S/05W-02J	0000311	MILESTONE RANCH	W	10" WELL		15	15	15	15	15	15
02S/05W-02J	3601996	MILESTONE RANCH	W	KLEIN /SAND RIVER #1		15	15	15	15	15	15
02S/05W-02L02S	3601782	RIVERSIDE CEMENT COMPANY	W		1964	0	0	0	0	0	0
02S/05W-02Q	3600972	BRADVICA, LOUIS	W	RNCH 1	1974	0	0	0	0	0	0
02S/05W-02Q07S	3602234	RIVERSIDE, CITY OF	W	JURUPA 6		0	0	0	0	0	0
02S/05W-02Q08S	3602748	RIVERSIDE, CITY OF	W	JURUPA 7		987	1,122	978	1,071	1,092	1,050
02S/05W-02R	0000301	MASON,	W	MASON	1997	0	0	0	0	0	0
02S/05W-02R	3603901	YEAGER, REIDMAN & HORN	W	MASON WELL #1		0	0	0	0	0	0
02S/05W-02R01S	3601493	RIVERSIDE, CITY OF	W	JURUPA 5	1980	0	0	0	0	0	0
02S/05W-02R02S	3601492	RIVERSIDE, CITY OF	W	JURUPA 4	1980	0	0	0	0	0	0
02S/05W-02R03S	3601491	RIVERSIDE, CITY OF	W	JURUPA 3	1980	0	0	0	0	0	0
02S/05W-11B	3601490	RIVERSIDE, CITY OF	W	JURUPA 1	1980	0	0	0	0	0	0
TOTALS FOR 138 WELLS						30,678	34,180	29,125	29,590	29,137	30,542

RIVERSIDE BASIN AREA
IN SAN BERNARDINO COUNTY
CROSS INDEX BY RECORDATION NUMBER

**WESTERN - SAN BERNARDINO WATERMASTER
VERIFIED PRODUCTION DATA
CROSS INDEX BY RECORDATION NUMBER
RIVERSIDE NORTH BASIN**

RECRDTN NUMBER	STATE WELL NUMBER	OWNER	WELL TYPE	LOCAL DESIGNATION	YEAR CLOSED	-----CALENDAR YEAR EXTRACTIONS-----					
						2008	2009	2010	2011	2012	AVG
0000301	02S/05W-02R	MASON,	W	MASON	1997	0	0	0	0	0	0
0000302	01S/05W-25P	CALIFORNIA PORTLAND CEMENT COMPANY	W	MILLER HONEY	1999	0	0	0	0	0	0
0000303	01S/05W-35B	CARSON, K.	W	-	1999	0	0	0	0	0	0
0000304	01S/05W-36B	FISHER, CHARLOTTE	W	OLD DUNN		0	1	1	1	1	1
0000305	01S/05W-36N	HOLTER RANCH	W	HENDRICKS	1998	0	0	0	0	0	0
0000306	01S/05W-36F	SAN BERNARDINO, CITY OF	W	RIX OVER EXTRACTIONS		7,883	7,729	8,533	8,094	5,968	7,641
0000307	01S/04W-30P01S	MCDANIEL & SON DAIRY	W	DAIRY		1	1	1	1	1	1
0000308	01S/05W-25R	WOODLAND FARMS	W	WARD DUCK		0	0	0	0	0	0
0000309	01S/05W-36M	KLECKLER, DON	W	15 HP	2007	0	0	0	0	0	0
0000310	01S/05W-25R	WOODLAND FARMS	W	WARD DUCK #2		48	5	5	5	1	13
0000311	02S/05W-02J	MILESTONE RANCH	W	10" WELL		15	15	15	15	15	15
3301088	01S/05W-36Q	RIVERSIDE, CITY OF	D	PELISIER		0	0	0	0	0	0
3301347	02S/05W-02C	INTER COUNTY WATER COMPANY	W	1	1981	0	0	0	0	0	0
3600074	01S/05W-23Q01S	WEST VALLEY WATER DIST	W	#29 / SLOVER & RIVER		0	0	0	0	0	0
3600097	02S/05W-01Q	HOWELL, ORUS	W		1991	0	0	0	0	0	0
3600413	01S/05W-34B01S	FIRESTONE GROUP LTD	W		1981	0	0	0	0	0	0
3600507	01S/05W-35D01S	HAMADA BROS	W	1	1991	0	0	0	0	0	0
3600535	01S/05W-36C09S	JURUPA WATER COMPANY	W	NO 1	1978	0	0	0	0	0	0
3600535-	01S/05W-36C11S	AGUA MANSA PROPERTIES, INC	W	3		27	29	29	28	27	28
3600536	01S/05W-36C10S	JURUPA WATER COMPANY	W	1 AND HALF	1974	0	0	0	0	0	0
3600537	02S/04W-05F02S	JUMAL WATER COMPANY	W		1985	0	0	0	0	0	0
3600627	01S/05W-25M	HOLLIDAY TRUCKING	W	1 COLTON		53	47	48	44	48	48
3600783	02S/04W-05C01S	RIVERSIDE, CITY OF-GAGE CANAL	W	DEBERRY		1,849	1,601	1,074	693	1,304	1,304
3600820	02S/04W-05P	JOHNSON, DOROTHY	W	1	1965	0	0	0	0	0	0
3600829	01S/04W-32G02S	EMPIRE WATER	W	1	1974	0	0	0	0	0	0
3600830	01S/04W-32G04S	EMPIRE WATER	W	2	1974	0	0	0	0	0	0
3600831	01S/04W-32H01S	EMPIRE WATER	W	4	1974	0	0	0	0	0	0
3600832	01S/04W-32B01S	EMPIRE WATER	W	350" #5		0	0	10	0	0	2
3600833	01S/04W-32G01S	EMPIRE WATER	W	6	1974	0	0	0	0	0	0
3600873	01S/05W-34K02S	GREEN ACRES MEMORIAL PARK ASS'N	W	NO 57, W'LY		98	98	0	0	0	39
3600874	02S/05W-02A	RIVERSIDE CEMENT COMPANY	W	58-1	1974	0	0	0	0	0	0
3600883	02S/05W-02G02S	RIVERSIDE CEMENT COMPANY	W	WRIGHT	1962	0	0	0	0	0	0
3600898	01S/05W-25R02S	RIVERSIDE, CITY OF	W	NO 6	1978	0	0	0	0	0	0
3600898-	01S/05W-25R04S	RIVERSIDE, CITY OF	W	TWIN BUTTE # 6		0	0	0	0	0	0
3600899	02S/04W-05F	WAGONER, JOHN J	W	DOM 1	1972	0	0	0	0	0	0

**WESTERN - SAN BERNARDINO WATERMASTER
VERIFIED PRODUCTION DATA
CROSS INDEX BY RECORDATION NUMBER
RIVERSIDE NORTH BASIN**

RECRDTN NUMBER	STATE WELL NUMBER	WELL OWNER	WELL TYPE	LOCAL DESIGNATION	YEAR CLOSED	-----CALENDAR YEAR EXTRACTIONS-----					
						2008	2009	2010	2011	2012	AVG
3600910	01S/05W-35G02S	CORRIDOR LAND COMPANY	W	1, AGUA MANSA	2005	0	0	0	0	0	0
3600911	01S/05W-35J	SERVICE ROCK CO	W	2	1974	0	0	0	0	0	0
3600915	01S/04W-31J01S	ROSEDALE WATER COMPANY	W	NEW WELL	1968	0	0	0	0	0	0
3600962	02S/04W-06A01S	MERRYFIELD WATER COMPANY	W	1		1	0	1	2	2	1
3600972	02S/05W-02Q	BRADVICA, LOUIS	W	RNCH 1	1974	0	0	0	0	0	0
3601004	01S/05W-23N01S	WEST VALLEY WATER DIST	W	#19	1973	0	0	0	0	0	0
3601009	02S/04W-06J01S	RIVERSIDE CANAL POWER CO.	W	RIV CANAL 60		0	0	0	0	0	0
3601011	02S/04W-06R04S	RIVERSIDE CANAL POWER CO.	W	RIV CANAL 61		1	1	1	1	1	1
3601020	02S/04W-06R05S	RIVERSIDE CANAL POWER CO.	W	RIV CANAL 62/CE #3		0	0	0	0	0	0
3601023	02S/04W-06R06S	RIVERSIDE CANAL POWER CO.	W	RIV CANAL 63/CE #4		0	0	0	0	0	0
3601088	01S/05W-33A01S	RANCHO DE SANTA FE	W	SANTA FE ELECTRIC A1	1974	0	0	0	0	0	0
3601100	01S/04W-31C	DAGGETT, FOREST N.	W	BARN 1	1972	0	0	0	0	0	0
3601101	01S/04W-31C	DAGGETT, FOREST N.	W	RIVER 2	1972	0	0	0	0	0	0
3601110	01S/05W-34A	GREEN ACRES	W	1		98	33	1	0	0	26
3601124	01S/05W-24R01S	GENERAL AMERICAN TRANSPORTATION CORP (W	1 SOUTH		5	5	6	4	5	5
3601221	02S/05W-01J03S	RIVERSIDE, CITY OF	W	DOM PELLISI		0	0	0	0	0	0
3601223	02S/05W-01G02S	RIVERSIDE, CITY OF	W	MAIN PELLISI		0	0	0	0	0	0
3601235	02S/05W-01G01S	RIVERSIDE, CITY OF	W	LA LOMA	1974	0	0	0	0	0	0
3601236	01S/05W-36L01S	RIVERSIDE, CITY OF	W	AGUA MANSA		0	0	0	0	0	0
3601271	02S/04W-06Q03S	RIVERSIDE, CITY OF	W	MARCY	1973	0	0	0	0	0	0
3601345	02S/04W-05E	HUNGERFORD, FRANK B.	W	JOHNSON	1960	0	0	0	0	0	0
3601422	02S/04W-06Q	ROQUET, HARRY V.	W	1 HOUSE		115	185	145	145	35	125
3601423	02S/04W-06N	ROQUET, HARRY V.	W	2 WEST	1991	0	0	0	0	0	0
3601424	02S/04W-06P	ROQUET, HARRY V.	D		1991	0	0	0	0	0	0
3601425	01S/05W-25A03S	CALIFORNIA PORTLAND CEMENT COMPANY	W	CPC #6		643	755	327	294	330	470
3601426	01S/04W-30D06S	CALIFORNIA PORTLAND CEMENT COMPANY	W	CPC #5		1,088	1,329	1,198	777	1,113	1,101
3601427	01S/05W-25A02S	CALIFORNIA PORTLAND CEMENT COMPANY	W	CPC #7		51	39	8	13	8	24
3601434	01S/05W-34D01S	WEST VALLEY WATER DIST	W	#25 14TH & LINDEN	1981	0	0	0	0	0	0
3601483	01S/04W-29H02S	RIVERSIDE, CITY OF	W	FLUME 1	1977	0	0	0	0	0	0
3601484	01S/04W-29H01S	RIVERSIDE, CITY OF	W	FLUME 2		954	2,749	1,577	1,667	1,675	1,724
3601485	01S/04W-29R01S	RIVERSIDE, CITY OF	W	FLUME 3		974	2,477	2,671	3,125	2,872	2,424
3601486	01S/04W-29Q03S	RIVERSIDE, CITY OF	W	FLUME 4		934	2,244	2,311	2,697	2,236	2,084
3601487	01S/04W-29Q01S	RIVERSIDE, CITY OF	W	FLUME 5	1977	0	0	0	0	0	0
3601488	02S/05W-01Q01S	RIVERSIDE, CITY OF	W	WILLIAMS	1974	0	0	0	0	0	0
3601488-	02S/05W-01Q01S	STAPAKIS, WILLIAM	W	WILLIAMS	1974	0	0	0	0	0	0

**WESTERN - SAN BERNARDINO WATERMASTER
VERIFIED PRODUCTION DATA
CROSS INDEX BY RECORDATION NUMBER
RIVERSIDE NORTH BASIN**

RECRDTN NUMBER	STATE WELL NUMBER	OWNER	WELL TYPE	LOCAL DESIGNATION	YEAR CLOSED	-----CALENDAR YEAR EXTRACTIONS-----					
						2008	2009	2010	2011	2012	AVG
3601490	02S/05W-11B	RIVERSIDE, CITY OF	W	JURUPA 1	1980	0	0	0	0	0	0
3601491	02S/05W-02R03S	RIVERSIDE, CITY OF	W	JURUPA 3	1980	0	0	0	0	0	0
3601492	02S/05W-02R02S	RIVERSIDE, CITY OF	W	JURUPA 4	1980	0	0	0	0	0	0
3601493	02S/05W-02R01S	RIVERSIDE, CITY OF	W	JURUPA 5	1980	0	0	0	0	0	0
3601509	02S/04W-06A03S	ELSINORE VALLEY M.W.D.	W	PALM AVE		2,043	1,010	0	8	0	612
3601524	01S/04W-28L01S	RIVERSIDE HIGHLAND WATER CO	W	3	1964	0	0	0	0	0	0
3601526	02S/04W-06R01S	RIVERSIDE HIGHLAND WATER CO	W	RN #7		154	546	1,253	1,129	699	756
3601531	01S/04W-33B05S	RIVERSIDE HIGHLAND WATER CO	W	RN #16	1964	0	0	0	0	0	0
3601532	01S/04W-28N05S	RIVERSIDE HIGHLAND WATER CO	W	RN #17		40	48	71	8	18	37
3601534	01S/04W-28L02S	RIVERSIDE HIGHLAND WATER CO	W	RN #20		95	0	1	0	0	19
3601539	01S/04W-32E01S	LA SIERRA WATER COMPANY	W	1	1962	0	0	0	0	0	0
3601540	01S/04W-32E03S	LA SIERRA WATER COMPANY	W	2	1974	0	0	0	0	0	0
3601541	01S/04W-32E06S	LA SIERRA WATER COMPANY	W	4	1974	0	0	0	0	0	0
3601542	01S/04W-32E05S	LA SIERRA WATER COMPANY	W	5	1974	0	0	0	0	0	0
3601543	01S/04W-32E02S	LA SIERRA WATER COMPANY	W	6	1974	0	0	0	0	0	0
3601544	01S/04W-32E07S	LA SIERRA WATER COMPANY	W	7	2006	0	0	0	0	0	0
3601545	01S/04W-32E11S	LA SIERRA WATER COMPANY	W	8	2006	0	0	0	0	0	0
3601546	01S/04W-32E09S	LA SIERRA WATER COMPANY	W	10	1992	0	0	0	0	0	0
3601547	01S/04W-32E10S	LA SIERRA WATER COMPANY	W	9	1974	0	0	0	0	0	0
3601549	01S/04W-28M01S	VILLELLI ENTERPRISES	W	2	1981	0	0	0	0	0	0
3601680	01S/05W-25L02S	RIALTO, CITY OF	W	DISPOSAL	1989	0	0	0	0	0	0
3601683	01S/05W-34B02S	WEST VALLEY WATER DIST	W	#26 END OF 12TH ST	1981	0	0	0	0	0	0
3601706	01S/05W-34L02S	GREEN ACRES MEMORIAL PARK ASS'N	W	8TH ST		133	133	146	90	90	118
3601707	01S/05W-34J01S	EL RIVINO COUNTRY CLUB	W	CACTUS		560	340	98	0	0	200
3601717	01S/05W-35R	CORRIDOR LAND COMPANY	W	DOUBLE D RANCH	2007	0	0	0	0	0	0
3601721	01S/05W-34K	GREEN ACRES MEMORIAL PARK ASS'N	W	56, E'LY		102	92	140	90	90	103
3601722	02S/05W-02A	MADISON, ERIN	W	58-1	1989	0	0	0	0	0	0
3601763	01S/05W-24M01S	WEST VALLEY WATER DIST	W	#18 / SLOVER MUTUAL	1981	0	0	0	0	0	0
3601782	02S/05W-02L02S	RIVERSIDE CEMENT COMPANY	W		1964	0	0	0	0	0	0
3601789	01S/04W-32M01S	RIVERSIDE HIGHLAND WATER CO	W	LV #1	1992	0	0	0	0	0	0
3601790	01S/04W-32M02S	RIVERSIDE HIGHLAND WATER CO	W	LV #2	1992	0	0	0	0	0	0
3601891	01S/05W-36F	ALLEE RANCH	W		1977	0	0	0	0	0	0
3601892	01S/05W-36F	AGUINAGA, ROGER	W		2007	0	0	0	0	0	0
3601953	01S/04W-32B02S	EMPIRE WATER	W	350" #7		0	0	0	0	0	0
3601961	01S/05W-25P	AGUA MANSA PROPERTIES, INC	W	AMRCH 1	1974	0	0	0	0	0	0

**WESTERN - SAN BERNARDINO WATERMASTER
VERIFIED PRODUCTION DATA
CROSS INDEX BY RECORDATION NUMBER
RIVERSIDE NORTH BASIN**

RECRDTN NUMBER	STATE WELL NUMBER	WELL OWNER	WELL TYPE	LOCAL DESIGNATION	YEAR CLOSED	-----CALENDAR YEAR EXTRACTIONS-----					
						2008	2009	2010	2011	2012	AVG
3601970	02S/04W-05M01S	GRAND TERRACE, CITY OF	W	PICO #64		0	0	0	0	0	0
3601996	02S/05W-02J	MILESTONE RANCH	W	KLEIN /SAND RIVER #1		15	15	15	15	15	15
3602028	01S/05W-25B02S	VULCAN - CAL MAT	W	SEINTURIER	1988	0	0	0	0	0	0
3602114	02S/05W-02G	MADISON, ERIN	W	63-1	1989	0	0	0	0	0	0
3602222	01S/05W-33A02S	RANCHO DE SANTA FE	W	GAS A-2	1989	0	0	0	0	0	0
3602233	01S/05W-35J	CANALE CATERING	W		1964	0	0	0	0	0	0
3602234	02S/05W-02Q07S	RIVERSIDE, CITY OF	W	JURUPA 6		0	0	0	0	0	0
3602326	01S/04W-30R	COUNTRY CLUB STORAGE	W		1981	0	0	0	0	0	0
3602357	01S/04W-34L	COLTON, CITY OF	W	6610 JAMES SULLIVAN		0	0	0	0	0	0
3602358	01S/04W-34L	COLTON, CITY OF	W	7418 J SULLIVAN		0	0	0	0	0	0
3602486	01S/04W-29Q04S	RIVERSIDE, CITY OF	W	FLUME 6		959	735	30	319	393	487
3602697	02S/05W-01P03S	BRADFORD, IVAN	W		1978	0	0	0	0	0	0
3602748	02S/05W-02Q08S	RIVERSIDE, CITY OF	W	JURUPA 7		987	1,122	978	1,071	1,092	1,050
3603117	02S/04W-05E01S	RIVERSIDE, CITY OF	W	VAN BUREN #1 -E'LY		1,915	2,192	1,898	1,689	1,967	1,932
3603118	02S/04W-05E02S	RIVERSIDE, CITY OF	W	VAN BUREN #2 - W'LY		2,079	2,095	1,580	1,475	1,693	1,784
3603139	01S/04W-32M04S	RIVERSIDE HIGHLAND WATER CO	W	LV #3		4	37	25	277	180	105
3603261	01S/05W-25M04S	HOLLIDAY TRUCKING	W	COLTON #2		52	54	54	52	53	53
3603598	01S/04W-18N03S	COLTON, CITY OF	W	#24		1,070	1,522	1,375	1,820	1,672	1,492
3603651	02S/05W-02H	CORRIDOR LAND COMPANY	W	SOUTH WELL, HOLLY	2000	0	0	0	0	0	0
3603652	02S/05W-01E	CORRIDOR LAND COMPANY	W	SOUTH #1 RIVERBOTTO	2007	0	0	0	0	0	0
3603669	01S/05W-24M02S	WEST VALLEY WATER DIST	W	#18A		2,269	938	0	1,073	2,085	1,273
3603670	01S/05W-36E03S	WEST VALLEY WATER DIST	W	#41		0	0	0	0	0	0
3603738	02S/04W-05F03S	RIVERSIDE HIGHLAND WATER CO	W	RN #6		1,352	2,075	1,637	1,099	1,461	1,525
3603759	01S/04W-30B01S	CALIFORNIA PORTLAND CEMENT COMPANY	W	WELL #8		2,001	1,870	1,857	1,671	0	1,480
3603901	02S/05W-02R	YEAGER, REIDMAN & HORN	W	MASON WELL #1		0	0	0	0	0	0
3603909	01S/04W-30A	CALIFORNIA PORTLAND CEMENT COMPANY	W	#9		6	9	1	1	0	3
3603918	01S/05W-36M	ASPHALT RECYCLING	W	SMALL		4	4	4	4	4	4
3603947	01S/05W-24H02S	SAN BERNARDINO COUNTY - ARROWHEAD REGI	W	NITRATE WELL		0	0	0	93	35	26
3603957	01S/04W-29G01S	COLTON, CITY OF	W	#30					0	0	0
3603958	01S/04W-29G02S	COLTON, CITY OF	W	#31					0	0	0
3603961	01S/04W-32F05S	RIVERSIDE, CITY OF	W	FLUME #7						1,948	390
3691486	01S/04W-29Q03S	LA SIERRA WATER COMPANY	W	FLUME 4	1984	0	0	0	0	0	0
3692486	01S/04W-29Q04S	LA SIERRA WATER COMPANY	W	FLUME 6	1982	0	0	0	0	0	0
TOTALS FOR 138 WELLS						30,678	34,180	29,125	29,590	29,137	30,542

TABLE NO. 1

VERIFIED EXTRACTIONS BY OWNERS WHICH HAVE
RECORDATION FILINGS WITH THE STATE WATER
RESOURCES CONTROL BOARD

**WESTERN - SAN BERNARDINO WATERMASTER
TABLE 1
VERIFIED EXTRACTIONS - FILED
RIVERSIDE NORTH BASIN**

RECRDTN NUMBER	STATE WELL NUMBER	WELL TYPE	LOCAL DESIGNATION	FC	-----BASE YEARS-----						-----CALENDAR YEAR EXTRACTIONS-----					
					1959	1960	1961	1962	1963	AVG	2008	2009	2010	2011	2012	AVG
AGUA MANSA PROPERTIES, INC																
3601961	01S/05W-25P	W	AMRCH 1	<input checked="" type="checkbox"/>	20	18	149	141	107	87	0	0	0	0	0	0
3600535-	01S/05W-36C11S	W	3	<input type="checkbox"/>						0	27	29	29	28	27	28
TOTALS FOR AGUA MANSA PROPERTIES, INC					20	18	149	141	107	87	27	29	29	28	27	28
AGUINAGA, ROGER																
3601892	01S/05W-36F	W		<input checked="" type="checkbox"/>	150	150	165	200	200	173	0	0	0	0	0	0
TOTALS FOR AGUINAGA, ROGER					150	150	165	200	200	173	0	0	0	0	0	0
ALLEE RANCH																
3601891	01S/05W-36F	W		<input checked="" type="checkbox"/>	0	1	1	0	0	0	0	0	0	0	0	0
TOTALS FOR ALLEE RANCH					0	1	1	0	0	0	0	0	0	0	0	0
ASPHALT RECYCLING																
3603918	01S/05W-36M	W	SMALL	<input type="checkbox"/>						0	4	4	4	4	4	4
TOTALS FOR ASPHALT RECYCLING										0	4	4	4	4	4	4
BRADFORD, IVAN																
3602697	02S/05W-01P03S	W		<input checked="" type="checkbox"/>						0	0	0	0	0	0	0
TOTALS FOR BRADFORD, IVAN										0	0	0	0	0	0	0
BRADVICA, LOUIS																
3600972	02S/05W-02Q	W	RNCH 1	<input checked="" type="checkbox"/>	105	123	83	78	61	90	0	0	0	0	0	0
TOTALS FOR BRADVICA, LOUIS					105	123	83	78	61	90	0	0	0	0	0	0
CALIFORNIA PORTLAND CEMENT COMPANY																
3603909	01S/04W-30A	W	#9	<input type="checkbox"/>						0	6	9	1	1	0	3
3603759	01S/04W-30B01S	W	WELL #8	<input type="checkbox"/>						0	2,001	1,870	1,857	1,671	0	1,480
3601426	01S/04W-30D06S	W	CPC #5	<input type="checkbox"/>	1,363	515	347	545	698	694	1,088	1,329	1,198	777	1,113	1,101
3601427	01S/05W-25A02S	W	CPC #7	<input type="checkbox"/>	4	1,328	1,090	178	322	584	51	39	8	13	8	24
3601425	01S/05W-25A03S	W	CPC #6	<input type="checkbox"/>	749	7	45	86	84	194	643	755	327	294	330	470
TOTALS FOR CALIFORNIA PORTLAND CEMENT COMPANY					2,116	1,850	1,482	809	1,104	1,472	3,789	4,002	3,391	2,756	1,451	3,078

WESTERN - SAN BERNARDINO WATERMASTER
TABLE 1
VERIFIED EXTRACTIONS - FILED
RIVERSIDE NORTH BASIN

RECRDTN NUMBER	STATE WELL NUMBER	WELL TYPE	LOCAL DESIGNATION	FC	-----BASE YEARS-----						-----CALENDAR YEAR EXTRACTIONS-----							
					1959	1960	1961	1962	1963	AVG	2008	2009	2010	2011	2012	AVG		
CANALE CATERING																		
3602233	01S/05W-35J	W		<input checked="" type="checkbox"/>	9	9	9	9	9	9	9	0	0	0	0	0	0	
TOTALS FOR CANALE CATERING					9	9	9	9	9	9	9	0	0	0	0	0	0	
COLTON, CITY OF																		
3603598	01S/04W-18N03S	W	#24	<input type="checkbox"/>								0	1,070	1,522	1,375	1,820	1,672	1,492
3603957	01S/04W-29G01S	W	#30	<input type="checkbox"/>								0			0	0	0	
3603958	01S/04W-29G02S	W	#31	<input type="checkbox"/>								0			0	0	0	
3602357	01S/04W-34L	W	6610 JAMES SULLIVA	<input type="checkbox"/>			11	11	11	7	0	0	0	0	0	0	0	
3602358	01S/04W-34L	W	7418 J SULLIVAN	<input type="checkbox"/>						0	0	0	0	0	0	0	0	
TOTALS FOR COLTON, CITY OF							11	11	11	7	1,070	1,522	1,375	1,820	1,672	1,492		
CORRIDOR LAND COMPANY																		
3600910	01S/05W-35G02S	W	1, AGUA MANSA	<input checked="" type="checkbox"/>	133	124	125	115	118	123	0	0	0	0	0	0	0	
3601717	01S/05W-35R	W	DOUBLE D RANCH	<input checked="" type="checkbox"/>	112	118	123	123	125	120	0	0	0	0	0	0	0	
3603652	02S/05W-01E	W	SOUTH #1 RIVERBOT	<input checked="" type="checkbox"/>						0	0	0	0	0	0	0	0	
3603651	02S/05W-02H	W	SOUTH WELL, HOLLY	<input checked="" type="checkbox"/>						0	0	0	0	0	0	0	0	
TOTALS FOR CORRIDOR LAND COMPANY					245	242	248	238	243	243	0	0	0	0	0	0	0	
COUNTRY CLUB STORAGE																		
3602326	01S/04W-30R	W		<input checked="" type="checkbox"/>	55	58	61	68	71	63	0	0	0	0	0	0	0	
TOTALS FOR COUNTRY CLUB STORAGE					55	58	61	68	71	63	0	0	0	0	0	0	0	
DAGGETT, FOREST N.																		
3601100	01S/04W-31C	W	BARN 1	<input checked="" type="checkbox"/>	227	169	174	181	0	150	0	0	0	0	0	0	0	
3601101	01S/04W-31C	W	RIVER 2	<input checked="" type="checkbox"/>	198	178	159	167	0	140	0	0	0	0	0	0	0	
TOTALS FOR DAGGETT, FOREST N.					425	347	333	348	0	291	0	0	0	0	0	0	0	
EL RIVINO COUNTRY CLUB																		
3601707	01S/05W-34J01S	W	CACTUS	<input type="checkbox"/>	733	733	733	733	733	733	560	340	98	0	0	0	200	
TOTALS FOR EL RIVINO COUNTRY CLUB					733	733	733	733	733	733	560	340	98	0	0	0	200	
ELSINORE VALLEY M.W.D.																		
3601509	02S/04W-06A03S	W	PALM AVE	<input type="checkbox"/>	1,203	1,319	1,363	1,163	1,265	1,263	2,043	1,010	0	8	0	0	612	

WESTERN - SAN BERNARDINO WATERMASTER
TABLE 1
VERIFIED EXTRACTIONS - FILED
RIVERSIDE NORTH BASIN

RECRDTN NUMBER	STATE WELL NUMBER	WELL TYPE	LOCAL DESIGNATION	FC	-----BASE YEARS-----						-----CALENDAR YEAR EXTRACTIONS-----					
					1959	1960	1961	1962	1963	AVG	2008	2009	2010	2011	2012	AVG
TOTALS FOR ELSINORE VALLEY M.W.D.					1,203	1,319	1,363	1,163	1,265	1,263	2,043	1,010	0	8	0	612
EMPIRE WATER																
3600832	01S/04W-32B01S	W	350" #5	<input type="checkbox"/>	723	784	571	0	180	452	0	0	10	0	0	2
3601953	01S/04W-32B02S	W	350" #7	<input type="checkbox"/>			640	2,989	2,512	1,228	0	0	0	0	0	0
3600833	01S/04W-32G01S	W	6	<input checked="" type="checkbox"/>	1,178	896	542	0	0	523	0	0	0	0	0	0
3600829	01S/04W-32G02S	W	1	<input checked="" type="checkbox"/>	26	10	0	0	0	7	0	0	0	0	0	0
3600830	01S/04W-32G04S	W	2	<input checked="" type="checkbox"/>	310	252	245	0	0	161	0	0	0	0	0	0
3600831	01S/04W-32H01S	W	4	<input checked="" type="checkbox"/>	58	30	150	0	0	48	0	0	0	0	0	0
TOTALS FOR EMPIRE WATER					2,295	1,972	2,148	2,989	2,692	2,419	0	0	10	0	0	2
FIRESTONE GROUP LTD																
3600413	01S/05W-34B01S	W		<input checked="" type="checkbox"/>	285	240	379	338	205	289	0	0	0	0	0	0
TOTALS FOR FIRESTONE GROUP LTD					285	240	379	338	205	289	0	0	0	0	0	0
GENERAL AMERICAN TRANSPORTATION CORP (GATX)																
3601124	01S/05W-24R01S	W	1 SOUTH	<input type="checkbox"/>	30	30	28	31	34	31	5	5	6	4	5	5
TOTALS FOR GENERAL AMERICAN TRANSPORTATION CORP (G					30	30	28	31	34	31	5	5	6	4	5	5
GRAND TERRACE, CITY OF																
3601970	02S/04W-05M01S	W	PICO #64	<input type="checkbox"/>			139	211	244	119	0	0	0	0	0	0
TOTALS FOR GRAND TERRACE, CITY OF							139	211	244	119	0	0	0	0	0	0
GREEN ACRES																
3601110	01S/05W-34A	W	1	<input type="checkbox"/>	161	156	182	115	97	142	98	33	1	0	0	26
TOTALS FOR GREEN ACRES					161	156	182	115	97	142	98	33	1	0	0	26
GREEN ACRES MEMORIAL PARK ASS'N																
3601721	01S/05W-34K	W	56, E'LY	<input type="checkbox"/>	1,087	915	314	543	520	676	102	92	140	90	90	103
3600873	01S/05W-34K02S	W	NO 57, W'LY	<input type="checkbox"/>	726	544	0	0	130	280	98	98	0	0	0	39
3601706	01S/05W-34L02S	W	8TH ST	<input type="checkbox"/>	105	110	112	115	124	113	133	133	146	90	90	118
TOTALS FOR GREEN ACRES MEMORIAL PARK ASS'N					1,918	1,569	426	658	774	1,069	333	323	286	180	180	260

**WESTERN - SAN BERNARDINO WATERMASTER
TABLE 1
VERIFIED EXTRACTIONS - FILED
RIVERSIDE NORTH BASIN**

RECRDTN NUMBER	STATE WELL NUMBER	WELL TYPE	LOCAL DESIGNATION	FC	-----BASE YEARS-----						-----CALENDAR YEAR EXTRACTIONS-----					
					1959	1960	1961	1962	1963	AVG	2008	2009	2010	2011	2012	AVG
HAMADA BROS																
3600507	01S/05W-35D01S	W	1	<input checked="" type="checkbox"/>	323	325	348	390	346	346	0	0	0	0	0	0
TOTALS FOR HAMADA BROS					323	325	348	390	346	346	0	0	0	0	0	0
HOLLIDAY TRUCKING																
3600627	01S/05W-25M	W	1 COLTON	<input type="checkbox"/>	158	155	151	148	149	152	53	47	48	44	48	48
3603261	01S/05W-25M04S	W	COLTON #2	<input type="checkbox"/>						0	52	54	54	52	53	53
TOTALS FOR HOLLIDAY TRUCKING					158	155	151	148	149	152	105	101	102	96	101	101
HOWELL, ORUS																
3600097	02S/05W-01Q	W		<input checked="" type="checkbox"/>	50	50	50	50	50	50	0	0	0	0	0	0
TOTALS FOR HOWELL, ORUS					50	50	50	50	50	50	0	0	0	0	0	0
HUNGERFORD, FRANK B.																
3601345	02S/04W-05E	W	JOHNSON	<input checked="" type="checkbox"/>	0	0	0	0	0	0	0	0	0	0	0	0
TOTALS FOR HUNGERFORD, FRANK B.					0	0	0	0	0	0	0	0	0	0	0	0
INTER COUNTY WATER COMPANY																
3301347	02S/05W-02C	W	1	<input checked="" type="checkbox"/>	145	141	133	117	131	133	0	0	0	0	0	0
TOTALS FOR INTER COUNTY WATER COMPANY					145	141	133	117	131	133	0	0	0	0	0	0
JOHNSON, DOROTHY																
3600820	02S/04W-05P	W	1	<input checked="" type="checkbox"/>	0	0	0	0	0	0	0	0	0	0	0	0
TOTALS FOR JOHNSON, DOROTHY					0	0	0	0	0	0	0	0	0	0	0	0
JUMAL WATER COMPANY																
3600537	02S/04W-05F02S	W		<input checked="" type="checkbox"/>	322	272	257	210	141	240	0	0	0	0	0	0
TOTALS FOR JUMAL WATER COMPANY					322	272	257	210	141	240	0	0	0	0	0	0
JURUPA WATER COMPANY																
3600535	01S/05W-36C09S	W	NO 1	<input checked="" type="checkbox"/>	58	67	73	73	29	60	0	0	0	0	0	0
3600536	01S/05W-36C10S	W	1 AND HALF	<input checked="" type="checkbox"/>	753	695	1,041	672	304	693	0	0	0	0	0	0
TOTALS FOR JURUPA WATER COMPANY					811	762	1,114	745	333	753	0	0	0	0	0	0

**WESTERN - SAN BERNARDINO WATERMASTER
TABLE 1
VERIFIED EXTRACTIONS - FILED
RIVERSIDE NORTH BASIN**

RECRDTN NUMBER	STATE WELL NUMBER	WELL TYPE	LOCAL DESIGNATION	FC	-----BASE YEARS-----						-----CALENDAR YEAR EXTRACTIONS-----					
					1959	1960	1961	1962	1963	AVG	2008	2009	2010	2011	2012	AVG
LA SIERRA WATER COMPANY																
3691486	01S/04W-29Q03S	W	FLUME 4	<input checked="" type="checkbox"/>							0	0	0	0	0	0
3692486	01S/04W-29Q04S	W	FLUME 6	<input checked="" type="checkbox"/>							0	0	0	0	0	0
3601539	01S/04W-32E01S	W	1	<input checked="" type="checkbox"/>	0	0	0	0	0	0	0	0	0	0	0	0
3601543	01S/04W-32E02S	W	6	<input checked="" type="checkbox"/>	188	191	132	59	5	115	0	0	0	0	0	0
3601540	01S/04W-32E03S	W	2	<input checked="" type="checkbox"/>	0	0	0	0	0	0	0	0	0	0	0	0
3601542	01S/04W-32E05S	W	5	<input checked="" type="checkbox"/>	0	0	0	0	0	0	0	0	0	0	0	0
3601541	01S/04W-32E06S	W	4	<input checked="" type="checkbox"/>	0	0	0	0	0	0	0	0	0	0	0	0
3601544	01S/04W-32E07S	W	7	<input checked="" type="checkbox"/>	1,083	981	1,254	646	108	814	0	0	0	0	0	0
3601546	01S/04W-32E09S	W	10	<input checked="" type="checkbox"/>	614	610	428	278	274	441	0	0	0	0	0	0
3601547	01S/04W-32E10S	W	9	<input checked="" type="checkbox"/>	474	403	568	31	0	295	0	0	0	0	0	0
3601545	01S/04W-32E11S	W	8	<input checked="" type="checkbox"/>	1,104	1,005	1,005	847	577	908	0	0	0	0	0	0
TOTALS FOR LA SIERRA WATER COMPANY					3,463	3,190	3,387	1,861	964	2,573	0	0	0	0	0	0
MADISON, ERIN																
3601722	02S/05W-02A	W	58-1	<input checked="" type="checkbox"/>	606	612	726	404	271	524	0	0	0	0	0	0
3602114	02S/05W-02G	W	63-1	<input checked="" type="checkbox"/>					27	5	0	0	0	0	0	0
TOTALS FOR MADISON, ERIN					606	612	726	404	298	529	0	0	0	0	0	0
MERRYFIELD WATER COMPANY																
3600962	02S/04W-06A01S	W	1	<input type="checkbox"/>	490	310	444	252	242	348	1	0	1	2	2	1
TOTALS FOR MERRYFIELD WATER COMPANY					490	310	444	252	242	348	1	0	1	2	2	1
MILESTONE RANCH																
3601996	02S/05W-02J	W	KLEIN /SAND RIVER #	<input type="checkbox"/>		0	18	67	161	49	15	15	15	15	15	15
TOTALS FOR MILESTONE RANCH						0	18	67	161	49	15	15	15	15	15	15
RANCHO DE SANTA FE																
3601088	01S/05W-33A01S	W	SANTA FE ELECTRIC	<input checked="" type="checkbox"/>	378	335	518	448	377	411	0	0	0	0	0	0
3602222	01S/05W-33A02S	W	GAS A-2	<input checked="" type="checkbox"/>						0	0	0	0	0	0	0
TOTALS FOR RANCHO DE SANTA FE					378	335	518	448	377	411	0	0	0	0	0	0

WESTERN - SAN BERNARDINO WATERMASTER

TABLE 1
VERIFIED EXTRACTIONS - FILED
RIVERSIDE NORTH BASIN

RECRDTN NUMBER	STATE WELL NUMBER	WELL TYPE	LOCAL DESIGNATION	FC	-----BASE YEARS-----						-----CALENDAR YEAR EXTRACTIONS-----					
					1959	1960	1961	1962	1963	AVG	2008	2009	2010	2011	2012	AVG
RIALTO, CITY OF																
3601680	01S/05W-25L02S	W	DISPOSAL	<input checked="" type="checkbox"/>	130	130	130	130	180	140	0	0	0	0	0	0
TOTALS FOR RIALTO, CITY OF					130	130	130	130	180	140	0	0	0	0	0	0
RIVERSIDE CANAL POWER CO.																
3601009	02S/04W-06J01S	W	RIV CANAL 60	<input type="checkbox"/>	25	35	38	51	53	40	0	0	0	0	0	0
3601011	02S/04W-06R04S	W	RIV CANAL 61	<input type="checkbox"/>	26	25	52	52	59	43	1	1	1	1	1	1
3601020	02S/04W-06R05S	W	RIV CANAL 62/CE #3	<input type="checkbox"/>	292	482	526	494	701	499	0	0	0	0	0	0
3601023	02S/04W-06R06S	W	RIV CANAL 63/CE #4	<input type="checkbox"/>	282	406	508	507	540	449	0	0	0	0	0	0
TOTALS FOR RIVERSIDE CANAL POWER CO.					625	948	1,124	1,104	1,353	1,031	1	1	1	1	1	1
RIVERSIDE CEMENT COMPANY																
3600874	02S/05W-02A	W	58-1	<input checked="" type="checkbox"/>	2	2	1	1	0	1	0	0	0	0	0	0
3600883	02S/05W-02G02S	W	WRIGHT	<input checked="" type="checkbox"/>	0	0	0	0	0	0	0	0	0	0	0	0
3601782	02S/05W-02L02S	W		<input checked="" type="checkbox"/>	105	105	105	105	0	84	0	0	0	0	0	0
TOTALS FOR RIVERSIDE CEMENT COMPANY					107	107	106	106	0	85	0	0	0	0	0	0
RIVERSIDE HIGHLAND WATER CO																
3601524	01S/04W-28L01S	W	3	<input checked="" type="checkbox"/>	43	150	13	0	0	41	0	0	0	0	0	0
3601534	01S/04W-28L02S	W	RN #20	<input type="checkbox"/>	973	428	460	560	795	643	95	0	1	0	0	19
3601532	01S/04W-28N05S	W	RN #17	<input type="checkbox"/>	944	1,164	1,129	820	1,029	1,017	40	48	71	8	18	37
3601789	01S/04W-32M01S	W	LV #1	<input checked="" type="checkbox"/>	461	409	664	621	572	545	0	0	0	0	0	0
3601790	01S/04W-32M02S	W	LV #2	<input checked="" type="checkbox"/>	0	0	0	0	69	14	0	0	0	0	0	0
3603139	01S/04W-32M04S	W	LV #3	<input type="checkbox"/>						0	4	37	25	277	180	105
3601531	01S/04W-33B05S	W	RN #16	<input checked="" type="checkbox"/>	42	2	4	30	4	16	0	0	0	0	0	0
3603738	02S/04W-05F03S	W	RN #6	<input type="checkbox"/>						0	1,352	2,075	1,637	1,099	1,461	1,525
3601526	02S/04W-06R01S	W	RN #7	<input type="checkbox"/>	1,338	1,226	1,834	1,549	1,429	1,475	154	546	1,253	1,129	699	756
TOTALS FOR RIVERSIDE HIGHLAND WATER CO					3,801	3,379	4,104	3,580	3,898	3,752	1,645	2,706	2,987	2,513	2,358	2,442
RIVERSIDE, CITY OF																
3601484	01S/04W-29H01S	W	FLUME 2	<input type="checkbox"/>	1,257	968	1,237	854	642	992	954	2,749	1,577	1,667	1,675	1,724
3601483	01S/04W-29H02S	W	FLUME 1	<input checked="" type="checkbox"/>	576	481	140	0	0	239	0	0	0	0	0	0
3601487	01S/04W-29Q01S	W	FLUME 5	<input checked="" type="checkbox"/>	1,665	1,198	981	657	636	1,027	0	0	0	0	0	0

WESTERN - SAN BERNARDINO WATERMASTER

TABLE 1
VERIFIED EXTRACTIIONS - FILED
RIVERSIDE NORTH BASIN

RECRDTN NUMBER	STATE WELL NUMBER	WELL TYPE	LOCAL DESIGNATION	FC	-----BASE YEARS-----						-----CALENDAR YEAR EXTRACTIIONS-----					
					1959	1960	1961	1962	1963	AVG	2008	2009	2010	2011	2012	AVG
3601486	01S/04W-29Q03S	W	FLUME 4	<input type="checkbox"/>	2,218	1,501	1,663	1,316	1,503	1,640	934	2,244	2,311	2,697	2,236	2,084
3602486	01S/04W-29Q04S	W	FLUME 6	<input type="checkbox"/>						0	959	735	30	319	393	487
3601485	01S/04W-29R01S	W	FLUME 3	<input type="checkbox"/>	1,497	979	1,862	1,458	1,165	1,392	974	2,477	2,671	3,125	2,872	2,424
3603961	01S/04W-32F05S	W	FLUME #7	<input type="checkbox"/>						0					1,948	390
3600898	01S/05W-25R02S	W	NO 6	<input checked="" type="checkbox"/>	1,196	1,042	869	0	0	621	0	0	0	0	0	0
3600898-	01S/05W-25R04S	W	TWIN BUTTE # 6	<input type="checkbox"/>				1,082	1,127	442	0	0	0	0	0	0
3601236	01S/05W-36L01S	W	AGUA MANSA	<input type="checkbox"/>	0	0	402	0	0	80	0	0	0	0	0	0
3301088	01S/05W-36Q	D	PELISIER	<input type="checkbox"/>	67	0	0	0	0	13	0	0	0	0	0	0
3603117	02S/04W-05E01S	W	VAN BUREN #1 -E'LY	<input type="checkbox"/>						0	1,915	2,192	1,898	1,689	1,967	1,932
3603118	02S/04W-05E02S	W	VAN BUREN #2 - W'LY	<input type="checkbox"/>						0	2,079	2,095	1,580	1,475	1,693	1,784
3601271	02S/04W-06Q03S	W	MARCY	<input checked="" type="checkbox"/>	61	20	25	47	42	39	0	0	0	0	0	0
3601235	02S/05W-01G01S	W	LA LOMA	<input checked="" type="checkbox"/>	0	0	0	0	0	0	0	0	0	0	0	0
3601223	02S/05W-01G02S	W	MAIN PELLISI	<input type="checkbox"/>	1,070	518	392	0	0	396	0	0	0	0	0	0
3601221	02S/05W-01J03S	W	DOM PELLISI	<input type="checkbox"/>	38	13	20	26	5	20	0	0	0	0	0	0
3601488	02S/05W-01Q01S	W	WILLIAMS	<input checked="" type="checkbox"/>	562	493	634	251	265	441	0	0	0	0	0	0
3602234	02S/05W-02Q07S	W	JURUPA 6	<input type="checkbox"/>						0	0	0	0	0	0	0
3602748	02S/05W-02Q08S	W	JURUPA 7	<input type="checkbox"/>						0	987	1,122	978	1,071	1,092	1,050
3601493	02S/05W-02R01S	W	JURUPA 5	<input checked="" type="checkbox"/>	1,500	1,301	1,590	1,345	1,200	1,387	0	0	0	0	0	0
3601492	02S/05W-02R02S	W	JURUPA 4	<input checked="" type="checkbox"/>	237	0	141	123	296	159	0	0	0	0	0	0
3601491	02S/05W-02R03S	W	JURUPA 3	<input checked="" type="checkbox"/>	720	1,060	1,141	862	796	916	0	0	0	0	0	0
3601490	02S/05W-11B	W	JURUPA 1	<input checked="" type="checkbox"/>	310	65	582	694	582	447	0	0	0	0	0	0
TOTALS FOR RIVERSIDE, CITY OF					12,974	9,639	11,679	8,715	8,259	10,253	8,802	13,614	11,045	12,043	13,876	11,876
RIVERSIDE, CITY OF-GAGE CANAL																
3600783	02S/04W-05C01S	W	DEBERRY	<input type="checkbox"/>	1,504	1,474	1,639	1,231	1,169	1,403	1,849	1,601	1,074	693	1,304	1,304
TOTALS FOR RIVERSIDE, CITY OF-GAGE CANAL					1,504	1,474	1,639	1,231	1,169	1,403	1,849	1,601	1,074	693	1,304	1,304
ROQUET, HARRY V.																
3601423	02S/04W-06N	W	2 WEST	<input checked="" type="checkbox"/>	0	0	0	0	0	0	0	0	0	0	0	0
3601424	02S/04W-06P	D		<input checked="" type="checkbox"/>	67	67	67	67	67	67	0	0	0	0	0	0
3601422	02S/04W-06Q	W	1 HOUSE	<input type="checkbox"/>	23	23	23	23	23	23	115	185	145	145	35	125

**WESTERN - SAN BERNARDINO WATERMASTER
TABLE 1
VERIFIED EXTRACTIONS - FILED
RIVERSIDE NORTH BASIN**

RECRDTN NUMBER	STATE WELL NUMBER	WELL LOCAL TYPE DESIGNATION	FC	-----BASE YEARS-----						-----CALENDAR YEAR EXTRACTIONS-----						
				1959	1960	1961	1962	1963	AVG	2008	2009	2010	2011	2012	AVG	
TOTALS FOR ROQUET, HARRY V.				90	90	90	90	90	90		115	185	145	145	35	125
ROSEDALE WATER COMPANY																
3600915	01S/04W-31J01S	W NEW WELL	<input checked="" type="checkbox"/>	45	45	25	25	25	33		0	0	0	0	0	
TOTALS FOR ROSEDALE WATER COMPANY				45	45	25	25	25	33		0	0	0	0	0	0
SAN BERNARDINO COUNTY - ARROWHEAD REGIONAL MEDI																
3603947	01S/05W-24H02S	W NITRATE WELL	<input type="checkbox"/>						0		0	0	0	93	35	26
TOTALS FOR SAN BERNARDINO COUNTY - ARROWHEAD REGI									0		0	0	0	93	35	26
SERVICE ROCK CO																
3600911	01S/05W-35J	W 2	<input checked="" type="checkbox"/>	123	104	46	7	8	58		0	0	0	0	0	
TOTALS FOR SERVICE ROCK CO				123	104	46	7	8	58		0	0	0	0	0	0
STAPAKIS, WILLIAM																
3601488-	02S/05W-01Q01S	W WILLIAMS	<input checked="" type="checkbox"/>			0	0	0	0		0	0	0	0	0	
TOTALS FOR STAPAKIS, WILLIAM						0	0	0	0		0	0	0	0	0	0
VILLELLI ENTERPRISES																
3601549	01S/04W-28M01S	W 2	<input checked="" type="checkbox"/>	600	680	820	680	580	672		0	0	0	0	0	
TOTALS FOR VILLELLI ENTERPRISES				600	680	820	680	580	672		0	0	0	0	0	0
VULCAN - CAL MAT																
3602028	01S/05W-25B02S	W SEINTURIER	<input type="checkbox"/>	61	140	238	68	135	128		0	0	0	0	0	
TOTALS FOR VULCAN - CAL MAT				61	140	238	68	135	128		0	0	0	0	0	0
WAGONER, JOHN J																
3600899	02S/04W-05F	W DOM 1	<input checked="" type="checkbox"/>	0	0	0	0	0	0		0	0	0	0	0	
TOTALS FOR WAGONER, JOHN J				0	0	0	0	0	0		0	0	0	0	0	0
WEST VALLEY WATER DIST																
3601004	01S/05W-23N01S	W #19	<input checked="" type="checkbox"/>	824	904	831	808	622	798		0	0	0	0	0	
3600074	01S/05W-23Q01S	W #29 / SLOVER & RIVE	<input type="checkbox"/>	150	150	150	150	150	150		0	0	0	0	0	
3601763	01S/05W-24M01S	W #18 / SLOVER MUTUA	<input checked="" type="checkbox"/>	35	40	46	35	35	38		0	0	0	0	0	

**WESTERN - SAN BERNARDINO WATERMASTER
TABLE 1
VERIFIED EXTRACTIONS - FILED
RIVERSIDE NORTH BASIN**

RECRDTN NUMBER	STATE WELL NUMBER	WELL TYPE	LOCAL DESIGNATION	FC	-----BASE YEARS-----						-----CALENDAR YEAR EXTRACTIONS-----						
					1959	1960	1961	1962	1963	AVG	2008	2009	2010	2011	2012	AVG	
3603669	01S/05W-24M02S	W	#18A	<input type="checkbox"/>							0	2,269	938	0	1,073	2,085	1,273
3601683	01S/05W-34B02S	W	#26 END OF 12TH ST	<input checked="" type="checkbox"/>	146	170	193	118	117	149	0	0	0	0	0	0	0
3601434	01S/05W-34D01S	W	#25 14TH & LINDEN	<input checked="" type="checkbox"/>	204	211	212	203	201	206	0	0	0	0	0	0	0
3603670	01S/05W-36E03S	W	#41	<input type="checkbox"/>						0	0	0	0	0	0	0	0
TOTALS FOR WEST VALLEY WATER DIST					1,359	1,475	1,432	1,314	1,125	1,341	2,269	938	0	1,073	2,085	1,273	
YEAGER, REIDMAN & HORN																	
3603901	02S/05W-02R	W	MASON WELL #1	<input type="checkbox"/>						0	0	0	0	0	0	0	0
TOTALS FOR YEAGER, REIDMAN & HORN										0	0	0	0	0	0	0	0
TOTALS FOR 127 WELLS					37,915	33,180	36,519	29,882	27,864	33,072	22,731	26,429	20,570	21,474	23,151	22,871	

TABLE NO. 2

VERIFIED EXTRACTIONS BY OWNERS WHICH
HAVE NOT FILED WITH THE STATE WATER
RESOURCES CONTROL BOARD

SANTA ANA RIVER WHITEWATER RIVER WATERSHEDS COOPERATIVE WATER RECORDATION PROGRAM

TABLE 2

VERIFIED EXTRACTIONS - NON-FILED
RIVERSIDE NORTH BASIN

RECRDTN NUMBER	STATE WELL NUMBER	WELL TYPE	LOCAL DESIGNATION	FC	-----BASE YEARS-----						-----CALENDAR YEAR EXTRACTIONS-----					
					1959	1960	1961	1962	1963	AVG	2008	2009	2010	2011	2012	AVG
MASON,																
0000301	02S/05W-02R	W	MASON	<input checked="" type="checkbox"/>							0	0	0	0	0	0
TOTALS FOR MASON,											0	0	0	0	0	0
CALIFORNIA PORTLAND CEMENT COMPANY																
0000302	01S/05W-25P	W	MILLER HONEY	<input checked="" type="checkbox"/>	0	0	0	0	0	0	0	0	0	0	0	0
TOTALS FOR CALIFORNIA PORTLAND CEMENT COMPANY											0	0	0	0	0	0
CARSON, K.																
0000303	01S/05W-35B	W	-	<input checked="" type="checkbox"/>	50	50	50	50	50	50	50	0	0	0	0	0
TOTALS FOR CARSON, K.											50	50	50	50	50	50
FISHER, CHARLOTTE																
0000304	01S/05W-36B	W	OLD DUNN	<input type="checkbox"/>							0	0	1	1	1	1
TOTALS FOR FISHER, CHARLOTTE											0	0	1	1	1	1
HOLTER RANCH																
0000305	01S/05W-36N	W	HENDRICKS	<input checked="" type="checkbox"/>	38	38	38	38	38	38	38	0	0	0	0	0
TOTALS FOR HOLTER RANCH											38	38	38	38	38	38
SAN BERNARDINO, CITY OF																
0000306	01S/05W-36F	W	RIX OVER EXTRACTI	<input type="checkbox"/>							0	7,883	7,729	8,533	8,094	5,968
TOTALS FOR SAN BERNARDINO, CITY OF											0	7,883	7,729	8,533	8,094	5,968
MCDANIEL & SON DAIRY																
0000307	01S/04W-30P01S	W	DAIRY	<input type="checkbox"/>	13	13	13	13	13	13	13	1	1	1	1	1
TOTALS FOR MCDANIEL & SON DAIRY											13	13	13	13	13	13
WOODLAND FARMS																
0000308	01S/05W-25R	W	WARD DUCK	<input type="checkbox"/>	556	556	556	556	556	556	556	0	0	0	0	0
TOTALS FOR WOODLAND FARMS											556	556	556	556	556	556
KLECKLER, DON																
0000309	01S/05W-36M	W	15 HP	<input checked="" type="checkbox"/>							0	0	0	0	0	0

SANTA ANA RIVER WHITEWATER RIVER WATERSHEDS COOPERATIVE WATER RECORDATION PROGRAM

TABLE 2

VERIFIED EXTRACTIONS - NON-FILED
RIVERSIDE NORTH BASIN

RECRDTN NUMBER	STATE WELL NUMBER	WELL TYPE	LOCAL DESIGNATION	FC	-----BASE YEARS-----						-----CALENDAR YEAR EXTRACTIONS-----											
					1959	1960	1961	1962	1963	AVG	2008	2009	2010	2011	2012	AVG						
TOTALS FOR KLECKLER, DON										0	0	0	0	0	0	0						
WOODLAND FARMS																						
0000310	01S/05W-25R	W	WARD DUCK #2	<input type="checkbox"/>						0	48	5	5	5	1	13						
TOTALS FOR WOODLAND FARMS										0	48	5	5	5	1	13						
MILESTONE RANCH																						
0000311	02S/05W-02J	W	10" WELL	<input type="checkbox"/>						0	15	15	15	15	15	15						
TOTALS FOR MILESTONE RANCH										0	15	15	15	15	15	15						
TOTALS FOR 11 WELLS											657	657	657	657	657	657	7,947	7,751	8,555	8,116	5,986	7,671

TABLE NO. 3
VERIFIED EXTRACTIONS
(FILED AND NON-FILED)
FROM RIVERSIDE BASIN AREA WITHIN RIVERSIDE COUNTY

**WESTERN - SAN BERNARDINO WATERMASTER
TABLE 3
VERIFIED EXTRACTIONS - FILED AND NONFILED DETAIL
RIVERSIDE NORTH BASIN**

RECRDTN NUMBER	STATE NUMBER	WELL TYPE	LOCAL DESIGNATION	-----BASE YEARS-----						-----CALENDAR YEAR EXTRACTIONS-----					
				1959	1960	1961	1962	1963	AVG	2008	2009	2010	2011	2012	AVG
AGUA MANSA PROPERTIES, INC															
3601961	01S/05W-25P	W	AMRCH 1	20	18	149	141	107	87	0	0	0	0	0	0
3600535-	01S/05W-36C11S	W	3						0	27	29	29	28	27	28
TOTALS FOR AGUA MANSA PROPERTIES, INC				20	18	149	141	107	87	27	29	29	28	27	28
AGUINAGA, ROGER															
3601892	01S/05W-36F	W		150	150	165	200	200	173	0	0	0	0	0	0
TOTALS FOR AGUINAGA, ROGER				150	150	165	200	200	173	0	0	0	0	0	0
ALLEE RANCH															
3601891	01S/05W-36F	W		0	1	1	0	0	0	0	0	0	0	0	0
TOTALS FOR ALLEE RANCH				0	1	1	0	0	0	0	0	0	0	0	0
ASPHALT RECYCLING															
3603918	01S/05W-36M	W	SMALL						0	4	4	4	4	4	4
TOTALS FOR ASPHALT RECYCLING									0	4	4	4	4	4	4
BRADFORD, IVAN															
3602697	02S/05W-01P03S	W							0	0	0	0	0	0	0
TOTALS FOR BRADFORD, IVAN									0	0	0	0	0	0	0
BRADVICA, LOUIS															
3600972	02S/05W-02Q	W	RNCH 1	105	123	83	78	61	90	0	0	0	0	0	0
TOTALS FOR BRADVICA, LOUIS				105	123	83	78	61	90	0	0	0	0	0	0
CALIFORNIA PORTLAND CEMENT COMPANY															
3603909	01S/04W-30A	W	#9						0	6	9	1	1	0	3
3603759	01S/04W-30B01S	W	WELL #8						0	2,001	1,870	1,857	1,671	0	1,480
3601426	01S/04W-30D06S	W	CPC #5	1,363	515	347	545	698	694	1,088	1,329	1,198	777	1,113	1,101
3601427	01S/05W-25A02S	W	CPC #7	4	1,328	1,090	178	322	584	51	39	8	13	8	24
3601425	01S/05W-25A03S	W	CPC #6	749	7	45	86	84	194	643	755	327	294	330	470
0000302	01S/05W-25P	W	MILLER HONEY	0	0	0	0	0	0	0	0	0	0	0	0
TOTALS FOR CALIFORNIA PORTLAND CEMENT COMPANY				2,116	1,850	1,482	809	1,104	1,472	3,789	4,002	3,391	2,756	1,451	3,078

**WESTERN - SAN BERNARDINO WATERMASTER
TABLE 3
VERIFIED EXTRACTIONS - FILED AND NONFILED DETAIL
RIVERSIDE NORTH BASIN**

RECRDTN NUMBER	STATE NUMBER	WELL TYPE	LOCAL DESIGNATION	-----BASE YEARS-----						-----CALENDAR YEAR EXTRACTIONS-----						
				1959	1960	1961	1962	1963	AVG	2008	2009	2010	2011	2012	AVG	
CANALE CATERING																
3602233	01S/05W-35J	W		9	9	9	9	9	9	0	0	0	0	0	0	
TOTALS FOR CANALE CATERING				9	9	9	9	9	9	0	0	0	0	0	0	
CARSON, K.																
0000303	01S/05W-35B	W	-	50	50	50	50	50	50	0	0	0	0	0	0	
TOTALS FOR CARSON, K.				50	50	50	50	50	50	0	0	0	0	0	0	
COLTON, CITY OF																
3603598	01S/04W-18N03S	W	#24							0	1,070	1,522	1,375	1,820	1,672	1,492
3603957	01S/04W-29G01S	W	#30							0				0	0	0
3603958	01S/04W-29G02S	W	#31							0				0	0	0
3602357	01S/04W-34L	W	6610 JAMES SULLIVAN			11	11	11	7	0	0	0	0	0	0	0
3602358	01S/04W-34L	W	7418 J SULLIVAN						0	0	0	0	0	0	0	0
TOTALS FOR COLTON, CITY OF						11	11	11	0	1,070	1,522	1,375	1,820	1,672	1,492	
CORRIDOR LAND COMPANY																
3600910	01S/05W-35G02S	W	1, AGUA MANSA	133	124	125	115	118	123	0	0	0	0	0	0	0
3601717	01S/05W-35R	W	DOUBLE D RANCH	112	118	123	123	125	120	0	0	0	0	0	0	0
3603652	02S/05W-01E	W	SOUTH #1 RIVERBOTTO						0	0	0	0	0	0	0	0
3603651	02S/05W-02H	W	SOUTH WELL, HOLLY						0	0	0	0	0	0	0	0
TOTALS FOR CORRIDOR LAND COMPANY				245	242	248	238	243	243	0	0	0	0	0	0	0
COUNTRY CLUB STORAGE																
3602326	01S/04W-30R	W		55	58	61	68	71	63	0	0	0	0	0	0	0
TOTALS FOR COUNTRY CLUB STORAGE				55	58	61	68	71	63	0	0	0	0	0	0	0
DAGGETT, FOREST N.																
3601100	01S/04W-31C	W	BARN 1	227	169	174	181	0	150	0	0	0	0	0	0	0
3601101	01S/04W-31C	W	RIVER 2	198	178	159	167	0	140	0	0	0	0	0	0	0
TOTALS FOR DAGGETT, FOREST N.				425	347	333	348	0	291	0	0	0	0	0	0	0
EL RIVINO COUNTRY CLUB																
3601707	01S/05W-34J01S	W	CACTUS	733	733	733	733	733	733	560	340	98	0	0	200	

**WESTERN - SAN BERNARDINO WATERMASTER
TABLE 3
VERIFIED EXTRACTIONS - FILED AND NONFILED DETAIL
RIVERSIDE NORTH BASIN**

RECRDTN NUMBER	STATE WELL NUMBER	WELL TYPE	LOCAL DESIGNATION	-----BASE YEARS-----						-----CALENDAR YEAR EXTRACTIONS-----					
				1959	1960	1961	1962	1963	AVG	2008	2009	2010	2011	2012	AVG
TOTALS FOR EL RIVINO COUNTRY CLUB				733	733	733	733	733	733	560	340	98	0	0	200
EL SINORE VALLEY M.W.D.															
3601509	02S/04W-06A03S	W	PALM AVE	1,203	1,319	1,363	1,163	1,265	1,263	2,043	1,010	0	8	0	612
TOTALS FOR EL SINORE VALLEY M.W.D.				1,203	1,319	1,363	1,163	1,265	1,263	2,043	1,010	0	8	0	612
EMPIRE WATER															
3600832	01S/04W-32B01S	W	350" #5	723	784	571	0	180	452	0	0	10	0	0	2
3601953	01S/04W-32B02S	W	350" #7			640	2,989	2,512	1,228	0	0	0	0	0	0
3600833	01S/04W-32G01S	W	6	1,178	896	542	0	0	523	0	0	0	0	0	0
3600829	01S/04W-32G02S	W	1	26	10	0	0	0	7	0	0	0	0	0	0
3600830	01S/04W-32G04S	W	2	310	252	245	0	0	161	0	0	0	0	0	0
3600831	01S/04W-32H01S	W	4	58	30	150	0	0	48	0	0	0	0	0	0
TOTALS FOR EMPIRE WATER				2,295	1,972	2,148	2,989	2,692	2,419	0	0	10	0	0	2
FIRESTONE GROUP LTD															
3600413	01S/05W-34B01S	W		285	240	379	338	205	289	0	0	0	0	0	0
TOTALS FOR FIRESTONE GROUP LTD				285	240	379	338	205	289	0	0	0	0	0	0
FISHER, CHARLOTTE															
0000304	01S/05W-36B	W	OLD DUNN						0	0	1	1	1	1	1
TOTALS FOR FISHER, CHARLOTTE									0	0	1	1	1	1	1
GENERAL AMERICAN TRANSPORTATION CORP (GATX)															
3601124	01S/05W-24R01S	W	1 SOUTH	30	30	28	31	34	31	5	5	6	4	5	5
TOTALS FOR GENERAL AMERICAN TRANSPORTATION CORP (G				30	30	28	31	34	31	5	5	6	4	5	5
GRAND TERRACE, CITY OF															
3601970	02S/04W-05M01S	W	PICO #64			139	211	244	119	0	0	0	0	0	0
TOTALS FOR GRAND TERRACE, CITY OF						139	211	244	0	0	0	0	0	0	0
GREEN ACRES															
3601110	01S/05W-34A	W	1	161	156	182	115	97	142	98	33	1	0	0	26
TOTALS FOR GREEN ACRES				161	156	182	115	97	142	98	33	1	0	0	26

**WESTERN - SAN BERNARDINO WATERMASTER
TABLE 3
VERIFIED EXTRACTIONS - FILED AND NONFILED DETAIL
RIVERSIDE NORTH BASIN**

RECRDTN NUMBER	STATE WELL NUMBER	WELL TYPE	LOCAL DESIGNATION	-----BASE YEARS-----						-----CALENDAR YEAR EXTRACTIONS-----					
				1959	1960	1961	1962	1963	AVG	2008	2009	2010	2011	2012	AVG
GREEN ACRES MEMORIAL PARK ASS'N															
3601721	01S/05W-34K	W	56, E'LY	1,087	915	314	543	520	676	102	92	140	90	90	103
3600873	01S/05W-34K02S	W	NO 57, W'LY	726	544	0	0	130	280	98	98	0	0	0	39
3601706	01S/05W-34L02S	W	8TH ST	105	110	112	115	124	113	133	133	146	90	90	118
TOTALS FOR GREEN ACRES MEMORIAL PARK ASS'N				1,918	1,569	426	658	774	1,069	333	323	286	180	180	260
HAMADA BROS															
3600507	01S/05W-35D01S	W	1	323	325	348	390	346	346	0	0	0	0	0	0
TOTALS FOR HAMADA BROS				323	325	348	390	346	346	0	0	0	0	0	0
HOLLIDAY TRUCKING															
3600627	01S/05W-25M	W	1 COLTON	158	155	151	148	149	152	53	47	48	44	48	48
3603261	01S/05W-25M04S	W	COLTON #2						0	52	54	54	52	53	53
TOTALS FOR HOLLIDAY TRUCKING				158	155	151	148	149	152	105	101	102	96	101	101
HOLTER RANCH															
0000305	01S/05W-36N	W	HENDRICKS	38	38	38	38	38	38	0	0	0	0	0	0
TOTALS FOR HOLTER RANCH				38	38	38	38	38	38	0	0	0	0	0	0
HOWELL, ORUS															
3600097	02S/05W-01Q	W		50	50	50	50	50	50	0	0	0	0	0	0
TOTALS FOR HOWELL, ORUS				50	50	50	50	50	50	0	0	0	0	0	0
HUNGERFORD, FRANK B.															
3601345	02S/04W-05E	W	JOHNSON	0	0	0	0	0	0	0	0	0	0	0	0
TOTALS FOR HUNGERFORD, FRANK B.				0	0	0	0	0	0	0	0	0	0	0	0
INTER COUNTY WATER COMPANY															
3301347	02S/05W-02C	W	1	145	141	133	117	131	133	0	0	0	0	0	0
TOTALS FOR INTER COUNTY WATER COMPANY				145	141	133	117	131	133	0	0	0	0	0	0
JOHNSON, DOROTHY															
3600820	02S/04W-05P	W	1	0	0	0	0	0	0	0	0	0	0	0	0
TOTALS FOR JOHNSON, DOROTHY				0	0	0	0	0	0	0	0	0	0	0	0

**WESTERN - SAN BERNARDINO WATERMASTER
TABLE 3
VERIFIED EXTRACTIONS - FILED AND NONFILED DETAIL
RIVERSIDE NORTH BASIN**

RECRDTN NUMBER	STATE WELL NUMBER	WELL TYPE	LOCAL DESIGNATION	-----BASE YEARS-----						-----CALENDAR YEAR EXTRACTIONS-----					
				1959	1960	1961	1962	1963	AVG	2008	2009	2010	2011	2012	AVG
JUMAL WATER COMPANY															
3600537	02S/04W-05F02S	W		322	272	257	210	141	240	0	0	0	0	0	0
TOTALS FOR JUMAL WATER COMPANY				322	272	257	210	141	240	0	0	0	0	0	0
JURUPA WATER COMPANY															
3600535	01S/05W-36C09S	W	NO 1	58	67	73	73	29	60	0	0	0	0	0	0
3600536	01S/05W-36C10S	W	1 AND HALF	753	695	1,041	672	304	693	0	0	0	0	0	0
TOTALS FOR JURUPA WATER COMPANY				811	762	1,114	745	333	753	0	0	0	0	0	0
KLECKLER, DON															
0000309	01S/05W-36M	W	15 HP							0	0	0	0	0	0
TOTALS FOR KLECKLER, DON										0	0	0	0	0	0
LA SIERRA WATER COMPANY															
3691486	01S/04W-29Q03S	W	FLUME 4						0	0	0	0	0	0	0
3692486	01S/04W-29Q04S	W	FLUME 6						0	0	0	0	0	0	0
3601539	01S/04W-32E01S	W	1	0	0	0	0	0	0	0	0	0	0	0	0
3601543	01S/04W-32E02S	W	6	188	191	132	59	5	115	0	0	0	0	0	0
3601540	01S/04W-32E03S	W	2	0	0	0	0	0	0	0	0	0	0	0	0
3601542	01S/04W-32E05S	W	5	0	0	0	0	0	0	0	0	0	0	0	0
3601541	01S/04W-32E06S	W	4	0	0	0	0	0	0	0	0	0	0	0	0
3601544	01S/04W-32E07S	W	7	1,083	981	1,254	646	108	814	0	0	0	0	0	0
3601546	01S/04W-32E09S	W	10	614	610	428	278	274	441	0	0	0	0	0	0
3601547	01S/04W-32E10S	W	9	474	403	568	31	0	295	0	0	0	0	0	0
3601545	01S/04W-32E11S	W	8	1,104	1,005	1,005	847	577	908	0	0	0	0	0	0
TOTALS FOR LA SIERRA WATER COMPANY				3,463	3,190	3,387	1,861	964	2,573	0	0	0	0	0	0
MADISON, ERIN															
3601722	02S/05W-02A	W	58-1	606	612	726	404	271	524	0	0	0	0	0	0
3602114	02S/05W-02G	W	63-1					27	5	0	0	0	0	0	0
TOTALS FOR MADISON, ERIN				606	612	726	404	298	529	0	0	0	0	0	0
MASON,															
0000301	02S/05W-02R	W	MASON							0	0	0	0	0	0

**WESTERN - SAN BERNARDINO WATERMASTER
TABLE 3
VERIFIED EXTRACTIONS - FILED AND NONFILED DETAIL
RIVERSIDE NORTH BASIN**

RECRDTN NUMBER	STATE WELL NUMBER	WELL TYPE	LOCAL DESIGNATION	-----BASE YEARS-----						-----CALENDAR YEAR EXTRACTIONS-----					
				1959	1960	1961	1962	1963	AVG	2008	2009	2010	2011	2012	AVG
TOTALS FOR MASON,									0	0	0	0	0	0	0
MCDANIEL & SON DAIRY															
0000307	01S/04W-30P01S	W	DAIRY	13	13	13	13	13	13	1	1	1	1	1	1
TOTALS FOR MCDANIEL & SON DAIRY				13	13	13	13	13	13	1	1	1	1	1	1
MERRYFIELD WATER COMPANY															
3600962	02S/04W-06A01S	W	1	490	310	444	252	242	348	1	0	1	2	2	1
TOTALS FOR MERRYFIELD WATER COMPANY				490	310	444	252	242	348	1	0	1	2	2	1
MILESTONE RANCH															
0000311	02S/05W-02J	W	10" WELL						0	15	15	15	15	15	15
3601996	02S/05W-02J	W	KLEIN /SAND RIVER #1		0	18	67	161	49	15	15	15	15	15	15
TOTALS FOR MILESTONE RANCH					0	18	67	161	0	30	30	30	30	30	30
RANCHO DE SANTA FE															
3601088	01S/05W-33A01S	W	SANTA FE ELECTRIC A1	378	335	518	448	377	411	0	0	0	0	0	0
3602222	01S/05W-33A02S	W	GAS A-2						0	0	0	0	0	0	0
TOTALS FOR RANCHO DE SANTA FE				378	335	518	448	377	411	0	0	0	0	0	0
RIALTO, CITY OF															
3601680	01S/05W-25L02S	W	DISPOSAL	130	130	130	130	180	140	0	0	0	0	0	0
TOTALS FOR RIALTO, CITY OF				130	130	130	130	180	140	0	0	0	0	0	0
RIVERSIDE CANAL POWER CO.															
3601009	02S/04W-06J01S	W	RIV CANAL 60	25	35	38	51	53	40	0	0	0	0	0	0
3601011	02S/04W-06R04S	W	RIV CANAL 61	26	25	52	52	59	43	1	1	1	1	1	1
3601020	02S/04W-06R05S	W	RIV CANAL 62/CE #3	292	482	526	494	701	499	0	0	0	0	0	0
3601023	02S/04W-06R06S	W	RIV CANAL 63/CE #4	282	406	508	507	540	449	0	0	0	0	0	0
TOTALS FOR RIVERSIDE CANAL POWER CO.				625	948	1,124	1,104	1,353	1,031	1	1	1	1	1	1
RIVERSIDE CEMENT COMPANY															
3600874	02S/05W-02A	W	58-1	2	2	1	1	0	1	0	0	0	0	0	0
3600883	02S/05W-02G02S	W	WRIGHT	0	0	0	0	0	0	0	0	0	0	0	0
3601782	02S/05W-02L02S	W		105	105	105	105	0	84	0	0	0	0	0	0

WESTERN - SAN BERNARDINO WATERMASTER
TABLE 3
VERIFIED EXTRACTIONS - FILED AND NONFILED DETAIL
RIVERSIDE NORTH BASIN

RECRDTN NUMBER	STATE NUMBER	WELL TYPE	WELL LOCAL DESIGNATION	-----BASE YEARS-----						-----CALENDAR YEAR EXTRACTIONS-----					
				1959	1960	1961	1962	1963	AVG	2008	2009	2010	2011	2012	AVG
TOTALS FOR RIVERSIDE CEMENT COMPANY				107	107	106	106	0	85	0	0	0	0	0	0
RIVERSIDE HIGHLAND WATER CO															
3601524	01S/04W-28L01S	W	3	43	150	13	0	0	41	0	0	0	0	0	0
3601534	01S/04W-28L02S	W	RN #20	973	428	460	560	795	643	95	0	1	0	0	19
3601532	01S/04W-28N05S	W	RN #17	944	1,164	1,129	820	1,029	1,017	40	48	71	8	18	37
3601789	01S/04W-32M01S	W	LV #1	461	409	664	621	572	545	0	0	0	0	0	0
3601790	01S/04W-32M02S	W	LV #2	0	0	0	0	69	14	0	0	0	0	0	0
3603139	01S/04W-32M04S	W	LV #3						0	4	37	25	277	180	105
3601531	01S/04W-33B05S	W	RN #16	42	2	4	30	4	16	0	0	0	0	0	0
3603738	02S/04W-05F03S	W	RN #6						0	1,352	2,075	1,637	1,099	1,461	1,525
3601526	02S/04W-06R01S	W	RN #7	1,338	1,226	1,834	1,549	1,429	1,475	154	546	1,253	1,129	699	756
TOTALS FOR RIVERSIDE HIGHLAND WATER CO				3,801	3,379	4,104	3,580	3,898	3,752	1,645	2,706	2,987	2,513	2,358	2,442
RIVERSIDE, CITY OF															
3601484	01S/04W-29H01S	W	FLUME 2	1,257	968	1,237	854	642	992	954	2,749	1,577	1,667	1,675	1,724
3601483	01S/04W-29H02S	W	FLUME 1	576	481	140	0	0	239	0	0	0	0	0	0
3601487	01S/04W-29Q01S	W	FLUME 5	1,665	1,198	981	657	636	1,027	0	0	0	0	0	0
3601486	01S/04W-29Q03S	W	FLUME 4	2,218	1,501	1,663	1,316	1,503	1,640	934	2,244	2,311	2,697	2,236	2,084
3602486	01S/04W-29Q04S	W	FLUME 6						0	959	735	30	319	393	487
3601485	01S/04W-29R01S	W	FLUME 3	1,497	979	1,862	1,458	1,165	1,392	974	2,477	2,671	3,125	2,872	2,424
3603961	01S/04W-32F05S	W	FLUME #7						0					1,948	390
3600898	01S/05W-25R02S	W	NO 6	1,196	1,042	869	0	0	621	0	0	0	0	0	0
3600898-	01S/05W-25R04S	W	TWIN BUTTE # 6				1,082	1,127	442	0	0	0	0	0	0
3601236	01S/05W-36L01S	W	AGUA MANSA	0	0	402	0	0	80	0	0	0	0	0	0
3301088	01S/05W-36Q	D	PELISIER	67	0	0	0	0	13	0	0	0	0	0	0
3603117	02S/04W-05E01S	W	VAN BUREN #1 -E'LY						0	1,915	2,192	1,898	1,689	1,967	1,932
3603118	02S/04W-05E02S	W	VAN BUREN #2 - W'LY						0	2,079	2,095	1,580	1,475	1,693	1,784
3601271	02S/04W-06Q03S	W	MARCY	61	20	25	47	42	39	0	0	0	0	0	0
3601235	02S/05W-01G01S	W	LA LOMA	0	0	0	0	0	0	0	0	0	0	0	0
3601223	02S/05W-01G02S	W	MAIN PELLISI	1,070	518	392	0	0	396	0	0	0	0	0	0
3601221	02S/05W-01J03S	W	DOM PELLISI	38	13	20	26	5	20	0	0	0	0	0	0
3601488	02S/05W-01Q01S	W	WILLIAMS	562	493	634	251	265	441	0	0	0	0	0	0
3602234	02S/05W-02Q07S	W	JURUPA 6						0	0	0	0	0	0	0
3602748	02S/05W-02Q08S	W	JURUPA 7						0	987	1,122	978	1,071	1,092	1,050

**WESTERN - SAN BERNARDINO WATERMASTER
TABLE 3
VERIFIED EXTRACTIONS - FILED AND NONFILED DETAIL
RIVERSIDE NORTH BASIN**

RECRDTN NUMBER	STATE WELL NUMBER	WELL TYPE	LOCAL DESIGNATION	-----BASE YEARS-----						-----CALENDAR YEAR EXTRACTIONS-----						
				1959	1960	1961	1962	1963	AVG	2008	2009	2010	2011	2012	AVG	
3601493	02S/05W-02R01S	W	JURUPA 5	1,500	1,301	1,590	1,345	1,200	1,387	0	0	0	0	0	0	
3601492	02S/05W-02R02S	W	JURUPA 4	237	0	141	123	296	159	0	0	0	0	0	0	
3601491	02S/05W-02R03S	W	JURUPA 3	720	1,060	1,141	862	796	916	0	0	0	0	0	0	
3601490	02S/05W-11B	W	JURUPA 1	310	65	582	694	582	447	0	0	0	0	0	0	
TOTALS FOR RIVERSIDE, CITY OF				12,974	9,639	11,679	8,715	8,259	10,253	8,802	13,614	11,045	12,043	13,876	11,876	
RIVERSIDE, CITY OF-GAGE CANAL																
3600783	02S/04W-05C01S	W	DEBERRY	1,504	1,474	1,639	1,231	1,169	1,403	1,849	1,601	1,074	693	1,304	1,304	
TOTALS FOR RIVERSIDE, CITY OF-GAGE CANAL				1,504	1,474	1,639	1,231	1,169	1,403	1,849	1,601	1,074	693	1,304	1,304	
ROQUET, HARRY V.																
3601423	02S/04W-06N	W	2 WEST	0	0	0	0	0	0	0	0	0	0	0	0	
3601424	02S/04W-06P	D		67	67	67	67	67	67	0	0	0	0	0	0	
3601422	02S/04W-06Q	W	1 HOUSE	23	23	23	23	23	23	115	185	145	145	35	125	
TOTALS FOR ROQUET, HARRY V.				90	90	90	90	90	90	115	185	145	145	35	125	
ROSEDALE WATER COMPANY																
3600915	01S/04W-31J01S	W	NEW WELL	45	45	25	25	25	33	0	0	0	0	0	0	
TOTALS FOR ROSEDALE WATER COMPANY				45	45	25	25	25	33	0	0	0	0	0	0	
SAN BERNARDINO COUNTY - ARROWHEAD REGIONAL MEDI																
3603947	01S/05W-24H02S	W	NITRATE WELL							0	0	0	0	93	35	26
TOTALS FOR SAN BERNARDINO COUNTY - ARROWHEAD REGI										0	0	0	0	93	35	26
SAN BERNARDINO, CITY OF																
0000306	01S/05W-36F	W	RIX OVER EXTRACTIONS							0	7,883	7,729	8,533	8,094	5,968	7,641
TOTALS FOR SAN BERNARDINO, CITY OF										0	7,883	7,729	8,533	8,094	5,968	7,641
SERVICE ROCK CO																
3600911	01S/05W-35J	W	2	123	104	46	7	8	58	0	0	0	0	0	0	
TOTALS FOR SERVICE ROCK CO				123	104	46	7	8	58	0	0	0	0	0	0	
STAPAKIS, WILLIAM																
3601488-	02S/05W-01Q01S	W	WILLIAMS			0	0	0	0	0	0	0	0	0	0	

WESTERN - SAN BERNARDINO WATERMASTER
TABLE 3
VERIFIED EXTRACTIONS - FILED AND NONFILED DETAIL
RIVERSIDE NORTH BASIN

RECRDTN NUMBER	STATE WELL NUMBER	WELL TYPE	LOCAL DESIGNATION	-----BASE YEARS-----					-----CALENDAR YEAR EXTRACTIONS-----								
				1959	1960	1961	1962	1963	AVG	2008	2009	2010	2011	2012	AVG		
TOTALS FOR STAPAKIS, WILLIAM						0	0	0	0		0	0	0	0	0	0	
VILLELLI ENTERPRISES																	
3601549	01S/04W-28M01S	W	2	600	680	820	680	580	672	0	0	0	0	0	0	0	
TOTALS FOR VILLELLI ENTERPRISES				600	680	820	680	580	672	0	0	0	0	0	0	0	0
VULCAN - CAL MAT																	
3602028	01S/05W-25B02S	W	SEINTURIER	61	140	238	68	135	128	0	0	0	0	0	0	0	
TOTALS FOR VULCAN - CAL MAT				61	140	238	68	135	128	0	0	0	0	0	0	0	0
WAGONER, JOHN J																	
3600899	02S/04W-05F	W	DOM 1	0	0	0	0	0	0	0	0	0	0	0	0	0	
TOTALS FOR WAGONER, JOHN J				0	0	0	0	0	0	0	0	0	0	0	0	0	0
WEST VALLEY WATER DIST																	
3601004	01S/05W-23N01S	W	#19	824	904	831	808	622	798	0	0	0	0	0	0	0	
3600074	01S/05W-23Q01S	W	#29 / SLOVER & RIVER	150	150	150	150	150	150	0	0	0	0	0	0	0	
3601763	01S/05W-24M01S	W	#18 / SLOVER MUTUAL	35	40	46	35	35	38	0	0	0	0	0	0	0	
3603669	01S/05W-24M02S	W	#18A						0	2,269	938	0	1,073	2,085	1,273		
3601683	01S/05W-34B02S	W	#26 END OF 12TH ST	146	170	193	118	117	149	0	0	0	0	0	0	0	
3601434	01S/05W-34D01S	W	#25 14TH & LINDEN	204	211	212	203	201	206	0	0	0	0	0	0	0	
3603670	01S/05W-36E03S	W	#41						0	0	0	0	0	0	0	0	
TOTALS FOR WEST VALLEY WATER DIST				1,359	1,475	1,432	1,314	1,125	1,341	2,269	938	0	1,073	2,085	1,273		
WOODLAND FARMS																	
0000308	01S/05W-25R	W	WARD DUCK	556	556	556	556	556	556	0	0	0	0	0	0	0	
0000310	01S/05W-25R	W	WARD DUCK #2						0	48	5	5	5	1	13		
TOTALS FOR WOODLAND FARMS				556	556	556	556	556	556	48	5	5	5	1	13		
YEAGER, REIDMAN & HORN																	
3603901	02S/05W-02R	W	MASON WELL #1						0	0	0	0	0	0	0	0	
TOTALS FOR YEAGER, REIDMAN & HORN									0	0	0	0	0	0	0	0	0
TOTALS FOR 138 WELLS				38,572	33,837	37,176	30,539	28,521	33,729	30,678	34,180	29,125	29,590	29,137	30,542		

WESTERN - SAN BERNARDINO WATERMASTER
TABLE 3
VERIFIED EXTRACTION, SUMMARY - FILED AND NON-FILED
RIVERSIDE NORTH BASIN

	-----BASE YEARS-----						-----CALENDAR YEAR EXTRACTIONS-----					
	1959	1960	1961	1962	1963	AVG	2008	2009	2010	2011	2012	AVG
AGUA MANSA PROPERTIES, INC	20	18	149	141	107	87	27	29	29	28	27	28
AGUINAGA, ROGER	150	150	165	200	200	173	0	0	0	0	0	0
ALLEE RANCH	0	1	1	0	0	0	0	0	0	0	0	0
ASPHALT RECYCLING						0	4	4	4	4	4	4
BRADFORD, IVAN						0	0	0	0	0	0	0
BRADVICA, LOUIS	105	123	83	78	61	90	0	0	0	0	0	0
CALIFORNIA PORTLAND CEMENT COMPANY	2,116	1,850	1,482	809	1,104	1,472	3,789	4,002	3,391	2,756	1,451	3,078
CANALE CATERING	9	9	9	9	9	9	0	0	0	0	0	0
CARSON, K.	50	50	50	50	50	50	0	0	0	0	0	0
COLTON, CITY OF			11	11	11	7	1,070	1,522	1,375	1,820	1,672	1,492
CORRIDOR LAND COMPANY	245	242	248	238	243	243	0	0	0	0	0	0
COUNTRY CLUB STORAGE	55	58	61	68	71	63	0	0	0	0	0	0
DAGGETT, FOREST N.	425	347	333	348	0	291	0	0	0	0	0	0
EL RIVINO COUNTRY CLUB	733	733	733	733	733	733	560	340	98	0	0	200
ELSINORE VALLEY M.W.D.	1,203	1,319	1,363	1,163	1,265	1,263	2,043	1,010	0	8	0	612
EMPIRE WATER	2,295	1,972	2,148	2,989	2,692	2,419	0	0	10	0	0	2
FIRESTONE GROUP LTD	285	240	379	338	205	289	0	0	0	0	0	0
FISHER, CHARLOTTE						0	0	1	1	1	1	1
GENERAL AMERICAN TRANSPORTATION CORP (GATX)	30	30	28	31	34	31	5	5	6	4	5	5
GRAND TERRACE, CITY OF			139	211	244	119	0	0	0	0	0	0
GREEN ACRES	161	156	182	115	97	142	98	33	1	0	0	26
GREEN ACRES MEMORIAL PARK ASS'N	1,918	1,569	426	658	774	1,069	333	323	286	180	180	260
HAMADA BROS	323	325	348	390	346	346	0	0	0	0	0	0
HOLLIDAY TRUCKING	158	155	151	148	149	152	105	101	102	96	101	101
HOLTER RANCH	38	38	38	38	38	38	0	0	0	0	0	0
HOWELL, ORUS	50	50	50	50	50	50	0	0	0	0	0	0
HUNGERFORD, FRANK B.	0	0	0	0	0	0	0	0	0	0	0	0
INTER COUNTY WATER COMPANY	145	141	133	117	131	133	0	0	0	0	0	0
JOHNSON, DOROTHY	0	0	0	0	0	0	0	0	0	0	0	0
JUMAL WATER COMPANY	322	272	257	210	141	240	0	0	0	0	0	0
JURUPA WATER COMPANY	811	762	1,114	745	333	753	0	0	0	0	0	0
KLECKLER, DON						0	0	0	0	0	0	0
LA SIERRA WATER COMPANY	3,463	3,190	3,387	1,861	964	2,573	0	0	0	0	0	0
MADISON, ERIN	606	612	726	404	298	529	0	0	0	0	0	0
MASON,						0	0	0	0	0	0	0
MCDANIEL & SON DAIRY	13	13	13	13	13	13	1	1	1	1	1	1
MERRYFIELD WATER COMPANY	490	310	444	252	242	348	1	0	1	2	2	1

**WESTERN - SAN BERNARDINO WATERMASTER
TABLE 3
VERIFIED EXTRACTION, SUMMARY - FILED AND NON-FILED
RIVERSIDE NORTH BASIN**

	-----BASE YEARS-----						-----CALENDAR YEAR EXTRACTIONS-----					
	1959	1960	1961	1962	1963	AVG	2008	2009	2010	2011	2012	AVG
MILESTONE RANCH		0	18	67	161	49	30	30	30	30	30	30
RANCHO DE SANTA FE	378	335	518	448	377	411	0	0	0	0	0	0
RIALTO, CITY OF	130	130	130	130	180	140	0	0	0	0	0	0
RIVERSIDE CANAL POWER CO.	625	948	1,124	1,104	1,353	1,031	1	1	1	1	1	1
RIVERSIDE CEMENT COMPANY	107	107	106	106	0	85	0	0	0	0	0	0
RIVERSIDE HIGHLAND WATER CO	3,801	3,379	4,104	3,580	3,898	3,752	1,645	2,706	2,987	2,513	2,358	2,442
RIVERSIDE, CITY OF	12,974	9,639	11,679	8,715	8,259	10,253	8,802	13,614	11,045	12,043	13,876	11,876
RIVERSIDE, CITY OF-GAGE CANAL	1,504	1,474	1,639	1,231	1,169	1,403	1,849	1,601	1,074	693	1,304	1,304
ROQUET, HARRY V.	90	90	90	90	90	90	115	185	145	145	35	125
ROSEDALE WATER COMPANY	45	45	25	25	25	33	0	0	0	0	0	0
SAN BERNARDINO COUNTY - ARROWHEAD REGIONAL MEDI						0	0	0	0	93	35	26
SAN BERNARDINO, CITY OF						0	7,883	7,729	8,533	8,094	5,968	7,641
SERVICE ROCK CO	123	104	46	7	8	58	0	0	0	0	0	0
STAPAKIS, WILLIAM			0	0	0	0	0	0	0	0	0	0
VILLELLI ENTERPRISES	600	680	820	680	580	672	0	0	0	0	0	0
VULCAN - CAL MAT	61	140	238	68	135	128	0	0	0	0	0	0
WAGONER, JOHN J	0	0	0	0	0	0	0	0	0	0	0	0
WEST VALLEY WATER DIST	1,359	1,475	1,432	1,314	1,125	1,341	2,269	938	0	1,073	2,085	1,273
WOODLAND FARMS	556	556	556	556	556	556	48	5	5	5	1	13
YEAGER, REIDMAN & HORN						0	0	0	0	0	0	0
TOTALS FOR ALL WELLS	38,572	33,837	37,176	30,539	28,521	33,729	30,678	34,180	29,125	29,590	29,137	30,542

TABLE NO. 4

GROUNDWATER PRODUCTION FROM THAT PART OF THE RIVERSIDE
GROUNDWATER BASIN SITUATED WITHIN SAN BERNARDINO COUNTY
BY RIVERSIDE COUNTY ENTITIES, A PART OF WHICH IS USED IN
SAN BERNARDINO COUNTY AND THE REMAINDER EXPORTED TO
RIVERSIDE COUNTY DURING THE 5-YEAR BASE PERIOD
ENDING IN 1963 AND FOR FOLLOWING CALENDAR
YEARS 1976 THROUGH THE CURRENT YEAR

TABLE NO. 4

GROUNDWATER PRODUCTION FROM THAT PART OF THE RIVERSIDE GROUNDWATER BASIN SITUATED WITHIN SAN BERNARDINO COUNTY BY RIVERSIDE COUNTY ENTITIES, A PART OF WHICH IS USED IN SAN BERNARDINO COUNTY AND THE REMAINDER EXPORTED TO RIVERSIDE COUNTY DURING THE 5-YEAR BASE PERIOD ENDING IN 1963 AND FOR THE FOLLOWING CALENDAR YEARS 1971 THROUGH THE CURRENT YEAR

CLASSIFIED ACCORDING TO SERVICE AREA
(Quantities in Acre Feet)

EXTRACTIONS FROM THE RIVERSIDE BASIN IN SAN BERNARDINO COUNTY BASIN AREA FOR USE WITHIN AND EXPORT THEREFROM

PLAINTIFFS	1959			1960			1961			1962			1963			5-Year Average		
	Total Extract	Deliveries		Total Extract	Deliveries		Total Extract	Deliveries		Total Extract	Deliveries		Total Extract	Deliveries		Total Extract	Deliveries	
		Del. in S.B. Co.	Del. in Riv. Co.		Del. in S.B. Co.	Del. in Riv. Co.		Del. in S.B. Co.	Del. in Riv. Co.		Del. in S.B. Co.	Del. in Riv. Co.		Del. in S.B. Co.	Del. in Riv. Co.		Del. in S.B. Co.	Del. in Riv. Co.
American Cement Co.	2,526	713	1,813	2,178	719	1,459	1,146	832	314	1,053	510	543	948	298	650	1,570	614	956
City of Riverside Domestic & irrigation	12,974	1,581	11,393	9,639	852	8,787	11,679	1,171	10,508	8,715	81	8,634	8,259	84	8,175	10,253	754	9,499
City of Riverside Gage Canal Company	1,504	0	1,504	1,474	0	1,474	1,639	0	1,639	1,231	0	1,231	1,169	0	1,169	1,403	0	1,403
Inter County Water Co. West Valley WD after 1988	145	57	88	141	55	86	133	52	81	117	46	71	131	51	80	133	52	81
Jurupa Water Company JCSD after 1988	811	0	811	762	0	762	1,114	0	1,114	745	0	745	333	0	333	753	0	753
La Sierra Water Company	3,463	725	2,738	3,190	698	2,492	3,387	598	2,789	1,861	289	1,572	964	274	690	2,573	517	2,056
Riverside Highland Water Company	3,801	1,317	2,484	3,379	890	2,489	4,104	994	3,110	3,580	1,043	2,537	3,898	1,246	2,652	3,752	1,098	2,654
Temescal Water Company	1,203	0	1,203	1,319	0	1,319	1,363	0	1,363	1,163	0	1,163	1,265	0	1,265	1,263	0	1,263
West Riverside 350" Water Company	2,295	0	2,295	1,972	0	1,972	2,148	0	2,148	2,989	0	2,989	2,692	0	2,692	2,419	0	2,419
TOTALS	28,722	4,393	24,329	24,054	3,214	20,840	26,713	3,647	23,066	21,454	1,969	19,485	19,659	1,953	17,706	24,120	3,035	21,085

Total Extract -- TOTAL EXTRACTIONS.
Del in S.B. Co. -- DELIVERY WITHIN SAN BERNARDINO COUNTY.
Del. in Riv. Co. -- DELIVERY WITHIN RIVERSIDE COUNTY.

See Report of the Watermaster, Volume 5, Distribution of Extractions, Chapter I, Table No. 52-A.
Same as Table 52-A, Volume 5.

TABLE NO. 4

GROUNDWATER PRODUCTION FROM THAT PART OF THE RIVERSIDE GROUNDWATER BASIN SITUATED WITHIN SAN BERNARDINO COUNTY BY RIVERSIDE COUNTY ENTITIES, A PART OF WHICH IS USED IN SAN BERNARDINO COUNTY AND THE REMAINDER EXPORTED TO RIVERSIDE COUNTY DURING THE 5-YEAR BASE PERIOD ENDING IN 1963 AND FOR THE FOLLOWING CALENDAR YEARS 1971 THROUGH THE CURRENT YEAR

CLASSIFIED ACCORDING TO SERVICE AREA
(Quantities in Acre Feet)

EXTRACTIONS FROM THE RIVERSIDE BASIN IN SAN BERNARDINO COUNTY BASIN AREA FOR USE WITHIN AND EXPORT THEREFROM

PLAINTIFFS	1971			1972			1973			1974			1975		
	Total Extract	Deliveries		Total Extract	Deliveries		Total Extract	Deliveries		Total Extract	Deliveries		Total Extract	Deliveries	
		Del. in S.B. Co.	Del. in Riv. Co.		Del. in S.B. Co.	Del. in Riv. Co.		Del. in S.B. Co.	Del. in Riv. Co.		Del. in S.B. Co.	Del. in Riv. Co.			
American Cement Co.	831	482	349	577	204	373	537	0	537	133	0	133	0	0	0
City of Riverside Domestic & irrigation	4,537	174	4,363	5,920	107	5,813	4,986	45	4,941	6,123	111	6,012	5,838	94	5,744
City of Riverside Gage Canal Company	567	0	567	778	0	778	222	0	222	472	98	374	645	77	568
Inter County Water Co.	83	32	51	95	37	58	157	61	96	206	81	125	225	88	137
Jurupa Water Company	94	-	94	376	-	376	200	-	200	402	-	402	592	-	592
La Sierra Water Company	4,739	0	4,739	4,709	0	4,709	2,644	0	2,644	1,933	0	1,933	2,311	0	2,311
Riverside Highland Water Company	5,304	1,526	3,778	4,229	1,249	2,980	4,074	1,227	2,847	3,371	1,109	2,262	3,016	966	2,050
Temescal Water Company	1,948	-	1,948	1,368	-	1,368	1,614	-	1,614	821	-	821	2,035	-	2,035
West Riverside 350" Water Company	2,219	-	2,219	2,133	-	2,133	885	-	885	1,521	-	1,521	1,526	-	1,526
TOTALS	20,322	2,214	18,108	20,185	1,597	18,588	15,319	1,333	13,986	14,982	1,399	13,583	16,188	1,225	14,963

Total Extract -- TOTAL EXTRACTIONS.
Del in S.B. Co. -- DELIVERY WITHIN SAN BERNARDINO COUNTY.
Del. in Riv. Co. -- DELIVERY WITHIN RIVERSIDE COUNTY.

See Report of the Watermaster, Volume 5, Distribution of Extractions, Chapter I, Table No. 52-A.
Same as Table 52-A, Volume 5.

TABLE NO. 4

GROUNDWATER PRODUCTION FROM THAT PART OF THE RIVERSIDE GROUNDWATER BASIN SITUATED WITHIN SAN BERNARDINO COUNTY BY RIVERSIDE COUNTY ENTITIES, A PART OF WHICH IS USED IN SAN BERNARDINO COUNTY AND THE REMAINDER EXPORTED TO RIVERSIDE COUNTY DURING THE 5-YEAR BASE PERIOD ENDING IN 1963 AND FOR THE FOLLOWING CALENDAR YEARS 1971 THROUGH THE CURRENT YEAR

CLASSIFIED ACCORDING TO SERVICE AREA
(Quantities in Acre Feet)

EXTRACTIONS FROM THE RIVERSIDE BASIN IN SAN BERNARDINO COUNTY BASIN AREA FOR USE WITHIN AND EXPORT THEREFROM

PLAINTIFFS	1976			1977			1978			1979			1980		
	Total Extract	Deliveries		Total Extract	Deliveries		Total Extract	Deliveries		Total Extract	Deliveries		Total Extract	Deliveries	
		Del. in S.B. Co.	Del. in Riv. Co.		Del. in S.B. Co.	Del. in Riv. Co.		Del. in S.B. Co.	Del. in Riv. Co.		Del. in S.B. Co.	Del. in Riv. Co.			
American Cement Co.	218	218	0	446	446	0	227	227	0	436	436	0	218	218	0
City of Riverside Domestic & irrigation	6,345	126	6,219	4,112	279	3,833	1,364	271	1,093	2,836	587	2,249	1,706	1,591	115
City of Riverside Gage Canal Company	440	62	378	389	6	383	734	4	730	413	4	409	2,032	4	2,028
Inter County Water Co. West Valley WD after 1988	230	152	78	207	137	70	145	96	49	225	149	76	228	150	78
Jurupa Water Company JCSD after 1988	637	-	637	756	-	756	1,118	-	1,118	421	-	421	478	-	478
La Sierra Water Company	2,682	0	2,682	2,862	0	2,862	1,500	0	1,500	1,736	0	1,736	1,102	0	1,102
Riverside Highland Water Company	3,592	1,108	2,484	4,699	1,117	3,582	3,923	1,302	2,621	3,876	1,194	2,682	4,284	1,447	2,837
Temescal Water Company	2,682	-	2,682	2,363	-	2,363	1,528	-	1,528	2,130	-	2,130	1,968	-	1,968
West Riverside 350" Water Company	981	-	981	583	0	583	416	0	416	889	0	889	585	0	585
TOTALS	17,807	1,666	16,141	16,417	1,985	14,432	10,955	1,900	9,055	12,962	2,370	10,592	12,601	3,410	9,191

Total Extract -- TOTAL EXTRACTIONS.
Del in S.B. Co. -- DELIVERY WITHIN SAN BERNARDINO COUNTY.
Del. in Riv. Co. -- DELIVERY WITHIN RIVERSIDE COUNTY.

See Report of the Watermaster, Volume 5, Distribution of Extractions, Chapter I, Table No. 52-A.
Same as Table 52-A, Volume 5.

GROUNDWATER PRODUCTION FROM THAT PART OF THE RIVERSIDE GROUNDWATER BASIN SITUATED
 WITHIN SAN BERNARDINO COUNTY BY RIVERSIDE COUNTY ENTITIES, A PART OF WHICH IS USED IN
 SAN BERNARDINO COUNTY AND THE REMAINDER EXPORTED TO RIVERSIDE COUNTY DURING THE
 5-YEAR BASE PERIOD ENDING IN 1963 AND FOR THE FOLLOWING CALENDAR YEARS 1971 THROUGH THE CURRENT YEAR

CLASSIFIED ACCORDING TO SERVICE AREA
 (Quantities in Acre Feet)

EXTRACTIONS FROM THE RIVERSIDE BASIN IN SAN BERNARDINO COUNTY BASIN AREA FOR USE WITHIN AND EXPORT THEREFROM

PLAINTIFFS	1981			1982			1983			1984			1985		
	Total Extract	Deliveries		Total Extract	Deliveries		Total Extract	Deliveries		Total Extract	Deliveries		Total Extract	Deliveries	
		Del. in S.B. Co.	Del. in Riv. Co.		Del. in S.B. Co.	Del. in Riv. Co.		Del. in S.B. Co.	Del. in Riv. Co.		Del. in S.B. Co.	Del. in Riv. Co.			
American Cement Co.	413	413	0	0	0	0	0	0	0	0	0	0	0	0	0
City of Riverside Domestic & irrigation	2,894	1,526	1,368	3,615	2,102	1,513	2,581	1,933	648	2,891	448	2,443	3,193	714	2,479
City of Riverside Gage Canal Company	2,467	3	2,464	1,645	1	1,644	1,019	1	1,018	2,046	2	2,044	1,861	1	1,860
Inter County Water Co. West Valley WD after 1988	175	115	60	200	132	68	154	102	52	207	136	71	196	129	67
Jurupa Water Company JCSD after 1988	62	-	62	793	-	793	351	-	351	634	-	634	1,217	-	1,217
La Sierra Water Company	2,233	-	2,233	29	-	29	14	-	14	0	-	0	0	-	0
Riverside Highland Water Company	4,965	1,676	3,289	3,337	1,248	2,089	2,535	889	1,646	4,545	1,367	3,178	4,475	1,299	3,176
Temescal Water Company	2,196	-	2,196	1,423	-	1,423	0	-	0	1,190	-	1,190	1,817	-	1,817
West Riverside 350" Water Company	1,395	-	1,395	905	-	905	46	-	46	0	-	0	585	-	585
TOTALS	16,800	3,733	13,067	11,947	3,483	8,464	6,700	2,925	3,775	11,513	1,953	9,560	13,344	2,143	11,201

Total Extract -- TOTAL EXTRACTIONS.
 Del in S.B. Co. -- DELIVERY WITHIN SAN BERNARDINO COUNTY.
 Del. in Riv. Co. -- DELIVERY WITHIN RIVERSIDE COUNTY.

See Report of the Watermaster, Volume 5, Distribution of Extractions, Chapter I, Table No. 52-A.
 Same as Table 52-A, Volume 5.

TABLE NO. 4

GROUNDWATER PRODUCTION FROM THAT PART OF THE RIVERSIDE GROUNDWATER BASIN SITUATED WITHIN SAN BERNARDINO COUNTY BY RIVERSIDE COUNTY ENTITIES, A PART OF WHICH IS USED IN SAN BERNARDINO COUNTY AND THE REMAINDER EXPORTED TO RIVERSIDE COUNTY DURING THE 5-YEAR BASE PERIOD ENDING IN 1963 AND FOR THE FOLLOWING CALENDAR YEARS 1971 THROUGH THE CURRENT YEAR

CLASSIFIED ACCORDING TO SERVICE AREA
(Quantities in Acre Feet)

EXTRACTIONS FROM THE RIVERSIDE BASIN IN SAN BERNARDINO COUNTY BASIN AREA FOR USE WITHIN AND EXPORT THEREFROM

PLAINTIFFS	1986			1987			1988			1989			1990		
	Total Extract	Deliveries		Total Extract	Deliveries		Total Extract	Deliveries		Total Extract	Deliveries		Total Extract	Deliveries	
		Del. in S.B. Co.	Del. in Riv. Co.		Del. in S.B. Co.	Del. in Riv. Co.		Del. in S.B. Co.	Del. in Riv. Co.		Del. in S.B. Co.	Del. in Riv. Co.			
American Cement Co.	0	0	0	0	0	0	0	0	0	0	-	-	0	-	-
City of Riverside Domestic & irrigation	2,342	117	2,225	1,762	87	1,675	3,315	58	3,257	10,194	59	10,135	10,983	1,011	9,972
City of Riverside Gage Canal Company	1,893	2	1,891	1,996	1	1,995	2,189	2	2,187	1,965	2	1,963	1,962	1	1,961
Inter County Water Co. West Valley WD after 1988	189	125	64	78	51	27	21	0	21	21	0	21	21	0	21
Jurupa Water Company JCSD after 1988	1,372	-	1,372	1,083	-	1,083	26	-	26	248	-	248	392	-	392
La Sierra Water Company	0	0	0	0	0	0	0	0	0	0	0	0	0	0	0
Riverside Highland Water Company	2,089	1,001	1,088	1,632	578	1,054	1,785	713	1,072	2,558	1,558	1,000	2,858	1,616	1,242
Temescal Water Company	2,051	-	2,051	1,878	-	1,878	2,360	-	2,360	2,790	-	2,790	2,283	-	2,283
West Riverside 350" Water Company	0	-	0	0	-	0	0	-	0	0	-	0	0	-	0
TOTALS	9,936	1,245	8,691	8,429	717	7,712	9,696	773	8,923	17,776	1,619	16,157	18,499	2,628	15,871

Total Extract -- TOTAL EXTRACTIONS.
Del in S.B. Co. -- DELIVERY WITHIN SAN BERNARDINO COUNTY.
Del. in Riv. Co. -- DELIVERY WITHIN RIVERSIDE COUNTY.

See Report of the Watermaster, Volume 5, Distribution of Extractions, Chapter I, Table No. 52-A.
Same as Table 52-A, Volume 5.

TABLE NO. 4

GROUNDWATER PRODUCTION FROM THAT PART OF THE RIVERSIDE GROUNDWATER BASIN SITUATED WITHIN SAN BERNARDINO COUNTY BY RIVERSIDE COUNTY ENTITIES, A PART OF WHICH IS USED IN SAN BERNARDINO COUNTY AND THE REMAINDER EXPORTED TO RIVERSIDE COUNTY DURING THE 5-YEAR BASE PERIOD ENDING IN 1963 AND FOR THE FOLLOWING CALENDAR YEARS 1971 THROUGH THE CURRENT YEAR

CLASSIFIED ACCORDING TO SERVICE AREA
(Quantities in Acre Feet)

EXTRACTIONS FROM THE RIVERSIDE BASIN IN SAN BERNARDINO COUNTY BASIN AREA FOR USE WITHIN AND EXPORT THEREFROM

PLAINTIFFS	1991			1992			1993			1994			1995		
	Total Extract	Deliveries		Total Extract	Deliveries		Total Extract	Deliveries		Total Extract	Deliveries		Total Extract	Deliveries	
		Del. in S.B. Co.	Del. in Riv. Co.		Del. in S.B. Co.	Del. in Riv. Co.		Del. in S.B. Co.	Del. in Riv. Co.		Del. in S.B. Co.	Del. in Riv. Co.			
American Cement Co.	-	-	-	-	-	-	-	-	-	-	-	-	-	-	-
City of Riverside Domestic & irrigation	13,203	1,005	12,198	10,343	334	10,009	9,300	69	9,231	8,203	72	8,131	10,755	0	10,755
City of Riverside Gage Canal Company	1,734	1	1,733	1,657	1	1,656	2,023	2	2,021	2,028	2	2,026	1,664	0	1,664
Inter County Water Co. West Valley WD after 1988	21	-	21	21	0	21	21	0	21	21	0	21	21	0	21
Jurupa Water Company JCSJ after 1988	646	-	646	357	-	357	362	0	362	413	0	413	1,520	0	1,520
La Sierra Water Company	0	0	0	0	0	0	0	0	0	0	0	0	0	0	0
Riverside Highland Water Company	3,581	1,978	1,603	2,215	1,244	971	3,034	1,664	1,370	3,285	1,672	1,613	3,126	1,696	1,430
Temescal Water Company	2,354	-	2,354	1,714	-	1,714	1,698	0	1,698	0	0	0	556	0	556
West Riverside 350" Water Company	0	-	0	0	-	0	0	0	0	0	0	0	0	0	0
TOTALS	21,539	2,984	18,555	16,307	1,579	14,728	16,438	1,735	14,703	13,950	1,746	12,204	17,642	1,696	15,946

Total Extract -- TOTAL EXTRACTIONS.
Del in S.B. Co. -- DELIVERY WITHIN SAN BERNARDINO COUNTY.
Del. in Riv. Co. -- DELIVERY WITHIN RIVERSIDE COUNTY.

See Report of the Watermaster, Volume 5, Distribution of Extractions, Chapter I, Table No. 52-A.
Same as Table 52-A, Volume 5.

TABLE NO. 4

GROUNDWATER PRODUCTION FROM THAT PART OF THE RIVERSIDE GROUNDWATER BASIN SITUATED
 WITHIN SAN BERNARDINO COUNTY, A PART OF WHICH IS USED IN
 SAN BERNARDINO COUNTY AND THE REMAINDER EXPORTED TO RIVERSIDE COUNTY DURING THE
 5-YEAR BASE PERIOD ENDING IN 1963 AND FOR THE FOLLOWING CALENDAR YEARS 1976 THROUGH THE CURRENT YEAR

CLASSIFIED ACCORDING TO SERVICE AREA
 (Quantites in Acre Feet)

EXTRACTIONS FROM RIVERSIDE BASIN AREA WITHIN SAN BERNARDINO COUNTY FOR USE WITHIN AND EXPORT THEREFROM

PLAINTIFFS	1996			1997			1998			1999			2000		
	Total Extract	Deliveries		Total Extract	Deliveries		Total Extract	Deliveries		Total Extract	Deliveries		Total Extract	Deliveries	
		Del. in S.B. Co.	Del. in Riv. Co.		Del. in S.B. Co.	Del. in Riv. Co.		Del. in S.B. Co.	Del. in Riv. Co.		Del. in S.B. Co.	Del. in Riv. Co.			
Riverside Cement Co.*	-	-	-	-	-	-	-	-	-	-	-	-	-	-	-
City of Riverside Domestic & Irrigation	0	0	0	9,064	0	9,064	8,169	0	8,169	6,765	0	6,765	8,883	0	8,883
City of Riverside Gage Canal Company	1,664	0	1,664	1,706	0	1,706	1,591	0	1,591	1,823	0	1,823	2,051	0	2,051
Inter County Water Co. West Valley WD after 1988	21	-	21	21	-	21	21	-	21	21	-	21	21	-	21
Jurupa Community Services District Agua Mansa Properties after 1997	1,500	-	1,500	6	6	-	6	6	-	1	1	-	1	1	-
La Sierra Water Company	0	-	0	0	-	0	0	-	0	0	-	0	0	-	0
Riverside Highland Water Company	2,396	1,308	1,088	2,513	1,352	1,161	2,195	1,324	871	2,627	1,866	761	1,138	1,120	18
Temescal Water Company	25	-	25	97	-	97	194	-	194	0	-	0	1,037	-	1,037
West Riverside 350" Water Company	0	-	0	0	-	0	0	-	0	0	-	0	0	-	0
TOTALS	5,606	1,308	4,298	13,407	1,358	12,049	12,176	1,330	10,846	11,237	1,867	9,370	13,131	1,121	12,010

Total Extract -- TOTAL EXTRACTIONS

Del in S.B. Co. -- DELIVERY WITHIN SAN BERNARDINO COUNTY

Del. in Riv. Co. -- DELIVERY WITHIN RIVERSIDE COUNTY

Same as Table No. 52, Volume 5

* Name change from American Cement (Amcord) to Riverside Cement in 1981

TABLE NO. 4

GROUNDWATER PRODUCTION FROM THAT PART OF THE RIVERSIDE GROUNDWATER BASIN SITUATED
WITHIN SAN BERNARDINO COUNTY, A PART OF WHICH IS USED IN
SAN BERNARDINO COUNTY AND THE REMAINDER EXPORTED TO RIVERSIDE COUNTY DURING THE
5-YEAR BASE PERIOD ENDING IN 1963 AND FOR THE FOLLOWING CALENDAR YEARS 1976 THROUGH THE CURRENT YEAR

CLASSIFIED ACCORDING TO SERVICE AREA
(Quantities in Acre Feet)

EXTRACTIONS FROM RIVERSIDE BASIN AREA WITHIN SAN BERNARDINO COUNTY FOR USE WITHIN AND EXPORT THEREFROM

PLAINTIFFS	2001			2002			2003			2004			2005		
	Total Extract	Deliveries		Total Extract	Deliveries		Total Extract	Deliveries		Total Extract	Deliveries		Total Extract	Deliveries	
		Del. in S.B. Co.	Del. in Riv. Co.		Del. in S.B. Co.	Del. in Riv. Co.		Del. in S.B. Co.	Del. in Riv. Co.		Del. in S.B. Co.	Del. in Riv. Co.			
Riverside Cement Co.*	-	-	-	-	-	-	-	-	-	-	-	-	-	-	-
City of Riverside Domestic & Irrigation	7,288	0	7,288	7,814	0	7,814	6,390	0	6,390	5,123	0	5,123	7,829	0	7,829
City of Riverside Gage Canal Company	1,491	0	1,491	1,286	0	1,286	1,339	0	1,339	1,125	0	1,125	1,354	-	1,354
Inter County Water Co. West Valley WD after 1988	21	-	21	21	-	21	21	-	21	21	-	21	21	-	21
Agua Mansa Properties was JCSD before 1997	1	1	-	1	1	-	1	1	-	0	-	-	34	34	-
La Sierra Water Company	0	-	0	0	-	0	0	-	0	0	-	0	0	-	0
Riverside Highland Water Company	1,341	1,280	61	2,577	2,440	137	1,885	1,698	187	2,793	2,499	294	2,031	1,836	195
Temescal Water Company	252	-	252	2,417	-	2,417	1,299	-	1,299	159	-	159	1	-	1
West Riverside 350" Water Company	0	-	0	0	-	0	0	-	0	0	-	0	0	-	0
TOTALS	10,394	1,281	9,113	14,116	2,441	11,675	10,935	1,699	9,236	9,221	2,499	6,722	11,270	1,870	9,400

Total Extract -- TOTAL EXTRACTIONS

Del in S.B. Co. -- DELIVERY WITHIN SAN BERNARDINO COUNTY

Del. in Riv. Co. -- DELIVERY WITHIN RIVERSIDE COUNTY

* Name change from American Cement (Amcord) to Riverside Cement in 1981

Same as Table No. 52, Volume 5

5/07 found error in Temescal formula - off one year !

TABLE NO. 4

GROUNDWATER PRODUCTION FROM THAT PART OF THE RIVERSIDE GROUNDWATER BASIN SITUATED
WITHIN SAN BERNARDINO COUNTY, A PART OF WHICH IS USED IN
SAN BERNARDINO COUNTY AND THE REMAINDER EXPORTED TO RIVERSIDE COUNTY DURING THE
5-YEAR BASE PERIOD ENDING IN 1963 AND FOR THE FOLLOWING CALENDAR YEARS 1976 THROUGH THE CURRENT YEAR

CLASSIFIED ACCORDING TO SERVICE AREA
(Quantites in Acre Feet)

EXTRACTIONS FROM RIVERSIDE BASIN AREA WITHIN SAN BERNARDINO COUNTY FOR USE WITHIN AND EXPORT THEREFROM

PLAINTIFFS	2006			2007			2008			2009			2010		
	Total Extract	Deliveries		Total Extract	Deliveries		Total Extract	Deliveries		Total Extract	Deliveries		Total Extract	Deliveries	
		Del. in S.B. Co.	Del. in Riv. Co.		Del. in S.B. Co.	Del. in Riv. Co.		Del. in S.B. Co.	Del. in Riv. Co.		Del. in S.B. Co.	Del. in Riv. Co.			
Riverside Cement Co.*	-	-	-	-	-	-	-	-	-	-	-	-	-	-	-
City of Riverside Domestic & Irrigation	10,276	0	10,276	5,688	0	5,688	8,802	0	8,802	13,614	0	13,614	11,045	0	11,045
City of Riverside Gage Canal Company	1,969	-	1,969	1,870	-	1,870	1,849	-	1,849	1,601	-	1,601	1,074	-	1,074
West Valley Water District (was InterCounty Water Co.)	21	-	21	21	-	21	277	-	277	275	-	275	275	-	275
Agua Mansa Properties (was Jurupa Water Co)	28	28	-	25	25	-	27	27	-	29	29	-	29	29	-
La Sierra Water Company	-	-	-	-	-	-	-	-	-	-	-	-	-	-	-
Riverside Highland Water Company	1,199	1,111	88	2,136	1,900	236	1,583	1,420	163	2,617	2,325	292	2,909	2,628	281
Esinore Valley MWD (was Temescal Water Co.)	515	-	515	788	-	788	2,043	-	2,043	1,010	-	1,010	0	-	0
Empire Water Company (was West Riverside 350")	0	-	0	0	-	0	0	-	0	0	-	0	0	-	0
TOTALS	14,008	1,139	12,869	10,528	1,925	8,603	14,581	1,447	13,134	19,146	2,354	16,792	15,332	2,657	12,675

Total Extract -- TOTAL EXTRACTIONS

Del in S.B. Co. -- DELIVERY WITHIN SAN BERNARDINO COUNTY

Del. in Riv. Co. -- DELIVERY WITHIN RIVERSIDE COUNTY

* Name change from American Cement (Amcord) to Riverside Cement in 1981

Same as Table No. 52A, Volume 5

5/07 found error in Temescal formula - off one year !

12/11 West Valley serving businesses in Agua Mansa area in riverside County, Rubidoux CSD provides sewer service

TABLE NO. 4

GROUNDWATER PRODUCTION FROM THAT PART OF THE RIVERSIDE GROUNDWATER BASIN SITUATED
WITHIN SAN BERNARDINO COUNTY, A PART OF WHICH IS USED IN
SAN BERNARDINO COUNTY AND THE REMAINDER EXPORTED TO RIVERSIDE COUNTY DURING THE
5-YEAR BASE PERIOD ENDING IN 1963 AND FOR THE FOLLOWING CALENDAR YEARS 1976 THROUGH THE CURRENT YEAR

CLASSIFIED ACCORDING TO SERVICE AREA
(Quantities in Acre Feet)

EXTRACTIONS FROM RIVERSIDE BASIN AREA WITHIN SAN BERNARDINO COUNTY FOR USE WITHIN AND EXPORT THEREFROM

PLAINTIFFS	2011			2012			2013			2014			2015		
	Total Extract	Deliveries		Total Extract	Deliveries		Total Extract	Deliveries		Total Extract	Deliveries		Total Extract	Deliveries	
		Del. in S.B. Co.	Del. in Riv. Co.		Del. in S.B. Co.	Del. in Riv. Co.		Del. in S.B. Co.	Del. in Riv. Co.		Del. in S.B. Co.	Del. in Riv. Co.			
Riverside Cement Co.*	-	-	-	-	-	-	-	-	-	-	-	-	-	-	-
City of Riverside Domestic & Irrigation	12,043	0	12,043	13,876	0	13,876									
City of Riverside Gage Canal Company	693	-	693	1,304	-	1,304		-			-			-	
West Valley Water District (was InterCounty Water Co.)	275	-	275	202	-	202					-			-	
Agua Mansa Properties (was Jurupa Water Co)	28	28	-	27	27	-					-			-	
La Sierra Water Company	-	-	-	-	-	-	-	-	-	-	-	-	-	-	-
Riverside Highland Water Company	2,439	2,182	257	2,271	2,040	231									
Esinore Valley MWD (was Temescal Water Co.)	8	-	8	0	-	0					-			-	
Empire Water Company (was West Riverside 350")	0	-	0	0	-	0					-			-	
TOTALS	15,486	2,210	13,276	17,680	2,067	15,613	0	0	0	0	0	0	0	0	0

Total Extract -- TOTAL EXTRACTIONS
Del in S.B. Co. -- DELIVERY WITHIN SAN BERNARDINO COUNTY
Del. in Riv. Co. -- DELIVERY WITHIN RIVERSIDE COUNTY

Same as Table No. 52A, Volume 5
* Name change from American Cement (Amcord) to Riverside Cement in 1981, operating/owned by TXI
12/11 West Valley serving businesses in Agua Mansa area in riverside County, Rubidoux CSD provides sewer service

TABLE NO. 5

GROUNDWATER PRODUCTION FROM THAT PART OF THE
RIVERSIDE GROUNDWATER BASIN SITUATED WITHIN SAN BERNARDINO
COUNTY BY SAN BERNARDINO COUNTY ENTITIES
FOR USE IN SAN BERNARDINO COUNTY
DURING THE 5-YEAR BASE PERIOD ENDING IN 1963
AND FOR FOLLOWING CALENDAR YEARS 1971 THROUGH THE CURRENT YEAR

TABLE NO. 5

page 1 of 2

GROUNDWATER PRODUCTION FROM THAT PART OF THE
RIVERSIDE GROUNDWATER BASIN SITUATED WITHIN SAN BERNARDINO COUNTY
BY SAN BERNARDINO COUNTY ENTITIES FOR USE IN SAN BERNARDINO COUNTY
DURING THE 5-YEAR BASE PERIOD ENDING IN 1963
AND FOR FOLLOWING CALENDAR YEARS 1971 THROUGH THE CURRENT YEAR
(Quantities in Acre Feet)

Verified Extractions from
Riverside Basin Area Within San Bernardino County

Calendar Year	Total Basin	by Riverside Co. Entities	Riverside Accumulated	by San Bernardino Co. Entities
(1)	(2)	(3)	(4)	
1959	38,572	28,722		9,850
1960	33,837	24,054		9,783
1961	37,176	26,713		10,463
1962	30,539	21,454		9,085
1963	28,521	19,659		8,862
Base Period Average	33,729	24,120		9,609
1971	29,070	20,322	20,322	8,748
1972	28,148	20,185	40,507	7,963
1973	21,809	15,319	55,826	6,490
1974	21,881	14,982	70,808	6,899
1975	22,701	16,188	86,996	6,513
1976	24,705	17,807	104,803	6,898
1977	23,506	16,417	121,220	7,089
1978	17,216	10,955	132,175	6,261
1979	20,024	12,962	145,137	7,062
1980	18,533	12,601	157,738	5,932
1981	23,611	16,800	174,538	6,811
1982	17,349	11,940	186,478	5,409
1983	11,904	6,700	193,178	5,204
1984	17,161	11,513	204,691	5,648
1985	19,392	13,344	218,035	6,048
1986	17,337	9,936	227,971	7,401
1987	15,803	8,429	236,400	7,374
1988	16,933	9,698	246,098	7,235
1989	25,557	17,776	263,874	7,781
1990	26,371	18,499	282,373	7,872
1991	28,011	21,539	303,912	6,472
1992	21,959 1)	16,307	320,219	5,652
1993	21,866	16,438	336,657	5,428
1994	19,661	13,950	350,607	5,711
1995	23,865 2)	17,642	368,249	6,223
1996	26,698 3)	14,712	382,961	11,986
1997	30,284 3)	12,397	395,358	17,887
1998	33,116	11,004	406,362	22,112
1999	35,482	13,583	419,945	21,899
2000	36,124 5) 6)	12,490	432,435	23,634
2001	31,423 4) 5) 6)	10,394	442,829	21,029
2002	28,042 5) 6)	14,116	456,945	13,926
2003	27,648 5) 6)	10,935	467,880	16,713
2004	24,779 5) 6)	9,221	477,101	15,558
2005	29,447 5) 6)	11,270	488,371	18,177

Column (1), Table No. 3 total verified production all facilities.

Column (2), Table No. 4 total extractions.

Column (4), Column (1) - (2)

Same as Vol. 5, Table No. 53.

1) corrected during 1993 verification (owl rock)

2) corrected during 1997 (Colton #24 reassigned to Riverside North, Kleckler corrected)

3) corrected during 1998 (RIX conversion error corrected)

4) corrected during 2002 (new Cal Mat and RH wells)

5) corrected during 2008, Roquet backfiled 115AF for 1999-2007

6) corrected during 2009 verification, backfiled SBCo Hospital well 2000-2005

TABLE NO. 5

GROUNDWATER PRODUCTION FROM THAT PART OF THE
RIVERSIDE GROUNDWATER BASIN SITUATED WITHIN SAN BERNARDINO COUNTY
BY SAN BERNARDINO COUNTY ENTITIES FOR USE IN SAN BERNARDINO COUNTY
DURING THE 5-YEAR BASE PERIOD ENDING IN 1963
AND FOR FOLLOWING CALENDAR YEARS 1971 THROUGH THE CURRENT YEAR
 (Quantities in Acre Feet)

Verified Extractions from
 Riverside Basin Area Within San Bernardino County

Calendar Year	Total Basin	by Riverside Co. Entities	Riverside Accumulated	by San Bernardino Co. Entities
	(1)	(2)	(3)	(4)
1959	38,522	28,722		9,850
1960	33,837	24,054		9,783
1961	37,176	26,713		10,463
1962	30,539	21,454		9,085
1963	28,521	19,659		8,862
Base Period Average	33,719	24,120		9,609
2006	30,045 1)	14,008	502,379	16,037
2007	27,491 1)	10,528	512,907	16,963
2008	30,678	14,581	527,488	16,097
2009	34,180	19,146	546,634	15,034
2010	29,125	15,332	561,966	13,793
2011	29,590	15,486	577,452	14,104
2012	29,137	17,680	595,132	11,457
2013				
2014				
2015				
2016				
2017				
2018				
2019				
2020				
2021				
2022				
2023				
2024				
2025				
2026				
2027				
2028				
2029				
2030				
2031				
2032				
2033				
2034				
2035				
2036				
2037				
2038				
2039				
2040				

Column (1), Table No. 3 total verified production all facilities.
 Column (2), Vol 3, Table No. 4 total extractions same as Table 52, ln 25
 Column (4), Column (1) - (2)
 Same as Vol. 5, Table No. 53.
 1) corrected during 2008, Roquet backfiled 115AF for 1999-2007

**WESTERN - SAN BERNARDINO WATERMASTER
FOR
WESTERN MUNICIPAL WATER DISTRICT et al.
vs.
EAST SAN BERNARDINO COUNTY WATER DISTRICT et al.
CASE NO. 78426 - COUNTY OF RIVERSIDE**

VOLUME 4 - 2012

**VERIFIED EXTRACTIONS FROM THE
RIVERSIDE BASIN AREA WITHIN
RIVERSIDE COUNTY
FOR
CALENDAR YEARS 1959-1963 & 2008-2012**

**ANNUAL ACCOUNTING
FOR INDIVIDUAL WELLS**

April 1, 2014

WATERMASTER
Douglas D. Headrick
John V. Rossi

REPORT OF WATERMASTER

Western Municipal Water District of Riverside County, et al.
Plaintiffs

vs.

East San Bernardino County Water District, et al.
Defendants

Superior Court of Riverside County

Case No. 78426

VOLUME 4 - 2012

VERIFIED EXTRACTIONS FROM THE
RIVERSIDE BASIN AREA WITHIN
RIVERSIDE COUNTY

for

CALENDAR YEARS 1959-1963 & 2008-2012

ANNUAL ACCOUNTING
FOR INDIVIDUAL WELLS

April 1, 2014

WATERMASTER

Douglas D. Headrick
John V. Rossi

VOLUME 4 - 2012

TABLE OF CONTENTS

	<u>Page</u>
INTRODUCTION	i
MAP - RIVERSIDE SOUTH BASIN AREA - ALL PRODUCERS	1
GRAPH - VERIFIED WATER PRODUCTION IN RIVERSIDE SOUTH BASIN AREA FOR CALENDAR YEARS 1959-63 and 1971 THROUGH PRESENT	2
RIVERSIDE BASIN AREA IN RIVERSIDE COUNTY CROSS INDEX BY OWNER	3
RIVERSIDE BASIN AREA IN RIVERSIDE COUNTY CROSS INDEX BY STATE WELL NUMBER	9
RIVERSIDE BASIN AREA IN RIVERSIDE COUNTY CROSS INDEX BY RECORDATION NUMBER	15
 <u>TABLE NO. 1</u>	
VERIFIED EXTRACTIONS BY OWNERS WHICH HAVE RECORDATION FILINGS WITH THE WATERMASTER	21
 <u>TABLE NO. 2</u>	
VERIFIED EXTRACTIONS BY OWNERS WHICH HAVE NOT FILED WITH THE WATERMASTER	32
 <u>TABLE NO. 3</u>	
VERIFIED EXTRACTIONS (FILED AND NON-FILED) FROM RIVERSIDE BASIN AREA WITHIN RIVERSIDE COUNTY	34
 <u>TABLE NO. 3</u>	
SUMMARY OF VERIFIED EXTRACTIONS (FILED AND NON-FILED) FROM RIVERSIDE BASIN AREA WITHIN RIVERSIDE COUNTY	44
 <u>TABLE NO. 4</u>	
TOTAL VERIFIED EXTRACTIONS FROM THE RIVERSIDE BASIN AREA WITHIN RIVERSIDE COUNTY FOR USE WITHIN RIVERSIDE COUNTY DURING THE 5-YEAR BASE PERIOD ENDING IN 1963 AND FOR CALENDAR YEARS 1971 THROUGH THE CURRENT YEAR.	47

VOLUME 4 - 2012

VERIFIED EXTRACTIONS FROM
THE RIVERSIDE BASIN AREA
WITHIN RIVERSIDE COUNTY FOR
CALENDAR YEARS 1959-1963 & 2008-2012

INTRODUCTION

The provisions of Paragraph IX(a) and IX(b) of the Judgment Case No. 78426 entered April 17, 1969, entitled "Extractions from the Portion of Riverside Basin Area in Riverside County which is Tributary to Riverside Narrows" provide as follows:

IX(a) "The average annual extractions from the portion of the Riverside Basin Area in Riverside County which is tributary to Riverside Narrows, for use in Riverside County, for the five-year period ending with 1963 are assumed to be 30,044 acre-feet; the correct figures shall be determined by the Watermaster as herein provided."

IX(b) "Over any five-year period, there may be extracted from such Basin Area, without replenishment obligation, an amount equal to five times such annual average for the Basin Area; provided, however, that if extractions in any year exceed such average by more than 20 percent, Western shall provide replenishment in the following year equal to the excess extractions over such 20 percent peaking allowance."

Paragraph IX(a) of the Judgment requires only that extractions from that part of the Riverside Basin in Riverside County which is tributary to the Riverside Narrows and used in Riverside County, be verified for the five calendar year base period ending in 1963. Accordingly, a verification of these extractions has been made, the results of which are shown in Table No. 3 on page 16 and averaged 29,634 acre-feet annually for each year during the base period.

Three indexes are included which provide a cross index by owner's name, State Well Number, and State Water Resources Control Board Recordation Number. In addition, each index shows the local designation of each well, if the State Board has closed the file, which year that occurred, and the last five years verified extractions.

Tables No. 1 and No. 2 in this report list the individual wells by the owner, the owner totals for each year in the five year base period ending in 1963, the five year period average, and the extractions for the years of 2008-2012. Table No. 1 lists the wells upon which filings have been made with the Watermaster, and Table No. 2 lists the wells upon which no filings have been made. Table No. 3 includes the detail and the summary of the verified extractions, by owner, as presented in Tables No. 1 and No. 2.

The judgment further provides in Paragraph XVI that the accounting is effective from and after January 1, 1971. The recent verified extractions from the Riverside Basin Area in Riverside County for calendar years 1971 through the current year have been determined to be as follows:

<u>Year</u>	<u>Verified Extractions</u>
Base Period Average	29,634 A.F.
1971	30,942 A.F.
1972	37,804 A.F.
1973	33,094 A.F.
1974	38,304 A.F.
1975	28,285 A.F.
1976	31,565 A.F.
1977	28,226 A.F.
1978	24,576 A.F.
1979	25,512 A.F.

Year	<u>Verified Extractions</u>
Base Period Average	29,634 A.F.
1980	30,206 A.F.
1981	30,243 A.F.
1982	20,365 A.F.
1983	22,991 A.F.
1984	32,466 A.F.
1985	23,970 A.F.
1986	24,549 A.F.
1987	24,202 A.F.
1988	24,470 A.F.
1989	34,417 A.F. 1) 2)
1990	31,760 A.F. 2)
1991	29,364 A.F. 3)
1992	29,538 A.F. 3)
1993	26,505 A.F.
1994	28,125 A.F.
1995	22,580 A.F.
1996	24,906 A.F.
1997	29,128 A.F.
1998	28,558 A.F.
1999	33,837 A.F. 5)
2000	32,263 A.F. 5)
2001	33,656 A.F. 5)
2002	31,013 A.F. 5)
2003	30,957 A.F. 5)
2004	35,530 A.F. 5)
2005	32,737 A.F. 4) 5)

1) Corrected during 1990 verification (Riv.Cement 60-1,Cof R Garner T&G,1st St)

2) Corrected during 1991 verification (Riv.Co. Pk, Edmund, wrong power meter #)

3) Corrected during 1993 verification (Riv.Cement 88-1)

4) Corrected during 2006 verification (Jurupa #21)

5) Corrected during 2007 verification (Hunter Engineering #3)

Year	Verified Extractions
Base Period Average	29,634 A.F.
2006	31,026 A.F.
2007	38,237 A.F. ²⁾
2008	31,205 A.F. ^{1) 2) 3)}
2009	35,519 A.F. ⁴⁾
2010	29,077 A.F. ⁵⁾
2011	30,510 A.F. ^{6) 7)}
2012	28,049 A.F. ⁸⁾

From Vol. 5, Table 56

Table No. 4 shows the total verified extractions from the Riverside Basin Area in Riverside County for use in Riverside County during the five year period ending in 1963 and for calendar years 1971 through the current year.

- 1) Starting in 2008, blow-off water from the City of Riverside Palmyrita Treatment Plant that is returned to the groundwater basin is not counted as extraction, Volume 5, Table 2, Line 88.
- 2) 2008 & 2009 Riverside Unified Schools backfiled on new well
- 3) 2008 production total of 31,219 AF (12/31/10) less 14 AF = 31,205 AF
- 4) 2009 production total of 35,541 AF (12/31/10) less 22 AF = 35,519 AF
- 5) 2010 production total of 29,090 AF (07/09/11) less 13 AF = 29,077 AF
- 6) 2011 production total of 30,578 AF (11/05/12) less 18 AF = 30,560 AF
- 7) 2011 correct, -50 AF for City of Riverside Mori well
- 6) 2012 no blow off in 2012, all water went to Riverside Canal.

ERRATA

Volume 4, Riverside South Basin

During the 2012 verification (August 2013) the following changes or corrections were made to the report.

The following backfilings/corrected filing were made during the year

3300598, Riverside County Parks, Edmund "D", 02S/05W-21K, corrected 2011 production from 140 AF to 175 AF. From SCE data 10/13

During the 2011 verification (July 2012) the following changes or corrections were made to the report.

The following new well was added to the files this year

3303129, Riverside County Parks, Sports Complex, 02S/05W-21E02S

The following well was closed during the year

3301915, Riverside City of, Freeway, 02S/05W-23Q03S noted abandoned on 2011 filing

The following backfilings/corrected filing were made during the year

3301384, Martin's Linens, 02S/05W-22R01S, corrected 2010 production from 196 AF to 64 AF. Had entered 64 MG, -132 AF

During the 2010 Verification, July 2011, no changes were made to the report.

During the 2009 verification (November 2010) the following changes or corrections were made to the report.

The following new well was added to the files this year

3303119, Riverside Unified School District, Beatty Elementary, 02S/05W-14B01S, backfiled on First Notice
2007 5 AF
2008 18 AF

The following 1 well was **re-opened** during the year
3302204, Riverside Co. Parks Dept, Picnic Lake 8", 02S/05W-
21M03S was reopened and is now named Ag Well II-Pic Lak 8

The following **corrections or additions** were made during the year
0000303, Carson, 01S05W-35B, lost its 1959 Base Period
verified production of 50 AF between the 1996 and 1997
report - added this water back.

3301088, City of Riverside, Pelisier Diversion, 01S/05W-36Q
removed 67 AF of **verified** extraction for 1958, there was
no verification before the 1959-63 Base Period.

The following **owner name changes** were made during the year
3301915, California Dept of Transportation, Freeway, 02S/05W-
23Q03S, transferred to City of Riverside who was the historic
operator of the File Closed well which is slated for
destruction during freeway widening project

During the 2008 verification (November 2009) the following
changes or corrections were made to the report.

The following 1 new well was **added** to the files this year
3303110, Heyming, Red Barn, 03S/05W-04N01S

The following 1 well was **closed** during the year
3302539, Rubidoux Community Services District, #12 Airport,
02S/05W-21C01S

The following 1 well was **re-opened** during the year
3302052, Canyon Crest Country Club, No. 1, 02S/04W-31R01S

The following **corrections or additions** were made during the year
3301286-, City of Riverside, Palmyrita #2, 02S/04W-07N03S,
verified correction to 2065 AF for 2007, +38 AF (filing
missed 2nd turn out)
3301287, City of Riverside, Electric St, 02S/04W-07L01S,
verified correction to 2506 AF for 2007, +113 AF (filing
missed 2nd turn out)

12/09 During the Riverside Basin Study WRIMES completed a detailed analysis of Watermaster data and found several inconsistencies in the data which are corrected below.

3300003, Scopes Corp, Cook 2 changed 1976 filing from 4 to 0 AF
3300598, Riverside County Parks Edmunds "D"

1987 from 683 AF to 0 AF

1988 from 750 AF to 0 AF

1989 from 910 AF to 0 AF

All these changes were footnoted in Volume 4 and the report totals DID NOT change with these correction. Appears to have been a database restore fault.

During the 2007 verification (November 2008) the following changes or corrections were made to the report.

Hunter Engineering, Well 3, had been estimating water use for duty demand. Well pulled and power records show no use from January 1999 forward

1999 corrected from 45 af to 0 af

2000 corrected from 45 af to 0 af

2001 corrected from 45 af to 0 af

2002 corrected from 45 af to 0 af

2003 corrected from 45 af to 0 af

2004 corrected from 45 af to 0 af

2005 corrected from 45 af to 0 af

Victoria Country Club completed a second well 3303015, 3300417- now acting as a backup.

California Baptist University filed on their irrigation well, non-filer 0000403, now 3303109

During the 2006 verification (March 2008) the following changes or corrections were made to the report.

Jurupa C.S.D. Well #21 was corrected for 2005 from 1,253 Af to 472 AF, a correction of -781 AF.

During the 2005 verification (May 2007) no changes or corrections were made to the report.

During the 2004 verification (June 2006) the following changes or corrections were made to the report.

West Riverside 350" well #1 3605005 is now
Indian Hills Water Conservation Corp well #1 3302980

West Riverside 350" well #2 3605006 is now
Indian Hills Water Conservation Corp well #2 3302979

Rubidoux CSD well #17 was 3305001 is now 3302985
Rubidoux CSD well #18 was 3305002 is now 3302986

During the 2003 verification (June 2005) no changes or corrections were made to the report.

During the 2002 verification (June 2004) no changes or corrections were made to the report.

During the 2001 verification (May 2003) no changes or corrections were made to the report.

During the 2000 verification (May 2002) the following two wells were added to the database,
City of Riverside, 3302890, Russell C.
Jurupa Community Services District, 3304000, #21.

During the 1999 verification (June 2001) the following changes were made to the report.
Fort Fremont Mutual Water Company wells 3301296 and 3301297 were transferred to Rubidoux C.S.D., both well are now FC.

During the 1998 verification (June 2000) no changes or corrections were made to the report.

During the 1997 verification (June 1999) no changes or corrections were made to the report.

During the 1996 verification (June 1998) no changes or corrections were made to the report.

During the 1995 verification (June 1997) no changes or corrections were made to the report.

During the 1994 verification (June 1996) the following changes or corrections were made to the report.

Wells used by Fairmont Park (C of R wells 3301082, 1851, 1635, 1077) now are metered. Estimated water use is 3.5 af/ac.

During the 1993 verification (May 1995) the following changes and corrections were made to the report:

Riverside Cement backfiled on Well 88-1 (3302605) 64 AF for 1991 and 990 AF for 1992.

Erin Madison Well 64-1 1992 verification of 205 AF was not entered into the computer till 11/94.

During the 1992 verification (November 1993) no changes or corrections were made to the report.

During the 1991 verification (November 1992) the following changes and corrections were made to the report:

The Riverside County Park "Edmund D" well (3300598) electrical meter number has been wrong since 1987. The meter actually supplies the park headquarters office complex and a small 3 hp well. Field notes from well measurements had power meter reading that were used to correct the verification.

year	verified	corrected	difference
1987	683	0	-683
1988	750	0	-750
1989	910	0	-910
1990	884	62	-822

During the 1990 verification (November 1991) the following changes and corrections were made to the report:

The Riverside Cement Company 60-1 well (3301610) was double counted as (0000021), net change of -1,061 A.F.

City of Riverside Garner T & G (3301075) was corrected to 9 A.F., net -4 A.F. The 1st Street well (3301284) was increased from 254 A.F. (was the December production figure) to 781 A.F., a net of +527 A.F.

Changes for the year total -538 A.F. (-1061 - 4 + 527).

During the 1989 verification (June 1991) the following changes and corrections were made to the report:

The Erin Madison Group purchased land and wells from the Riverside Cement Company (3301203, 3301473, 3301626-). The wells are now listed under Madison, including the past production figures.

Corrected 1988 data for Michael C., -508 A.F. Non-verified figures used in error.

During the 1988 verification (June 1990) the following changes and corrections were made to the report:

Canyon Crest County Club (3302052) 1987 production was verified in the amount of 9 A.F.

Hunter Engineering (3600609) 1987 production of 36 A.F. was not included on the 1987 verified printout.








City of Riverside Garner C (3302472) 1987 production of 1,769 A.F. was mis-located and during 1987 verification was placed in the Riverside North Basin.

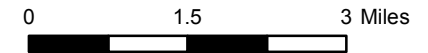
Net corrections $9 + 36 + 1,769 = 1,814$ A.F. increase from the 1987 verified amount of 23,071 A.F. to yield the 1988 verified figure of 24,885 A.F.

Riverside Cement Company's Falco well (3300371) was sold to Walter and Barbara Taylor.

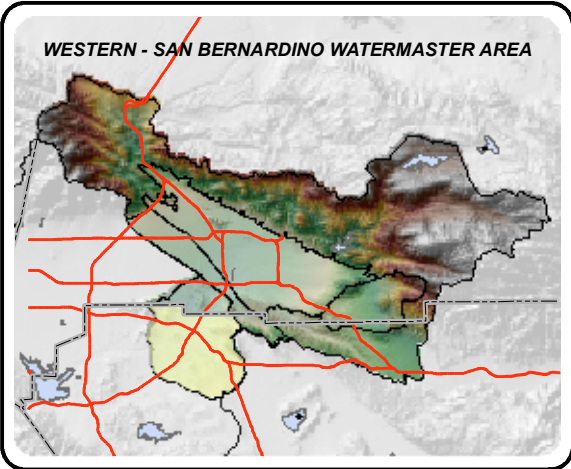
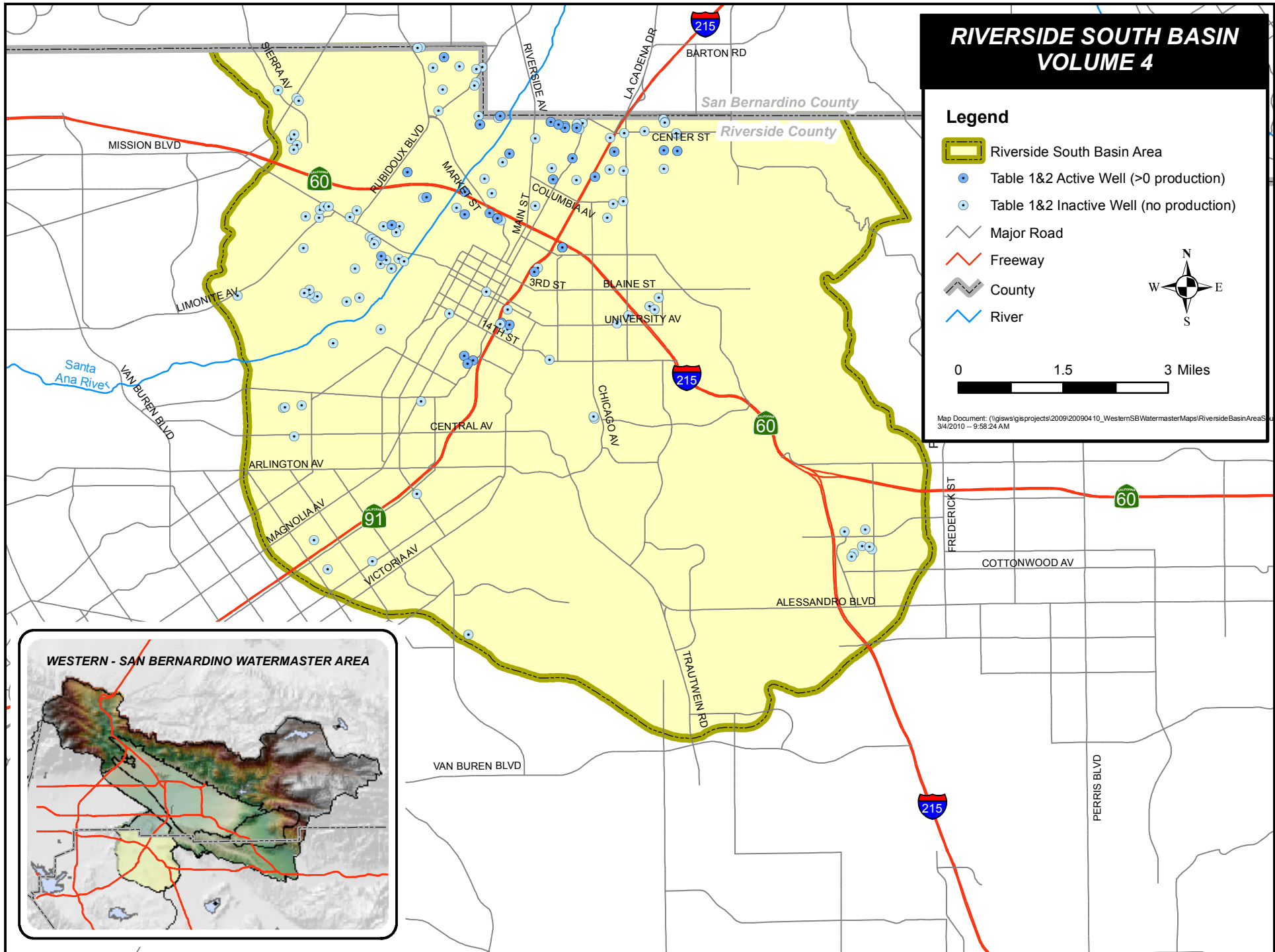
RIVERSIDE SOUTH BASIN VOLUME 4

Legend

-  Riverside South Basin Area
-  Table 1&2 Active Well (>0 production)
-  Table 1&2 Inactive Well (no production)
-  Major Road
-  Freeway
-  County
-  River

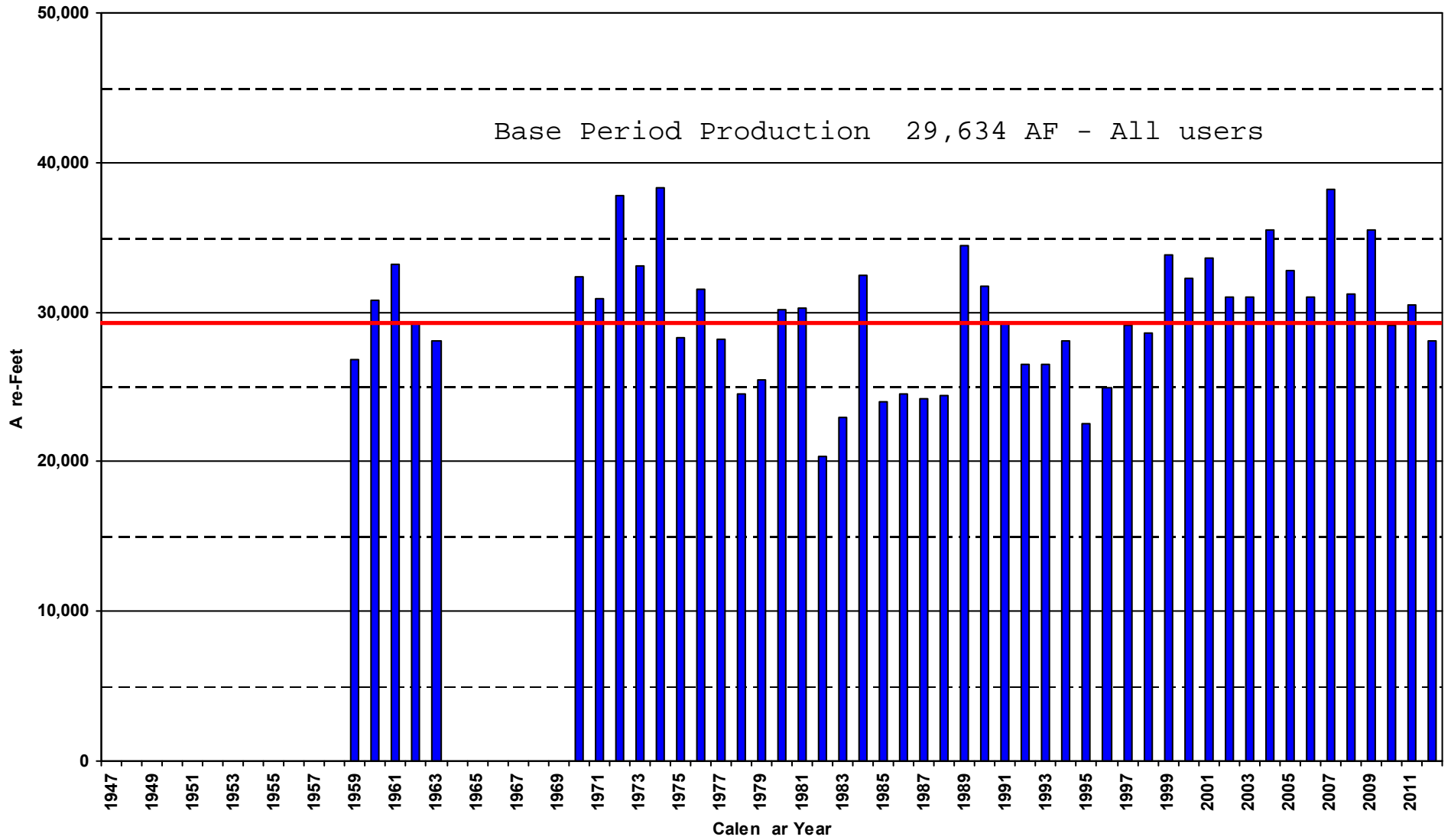


Map Document: (\\gis\sw\gis\projects\2009\20090410_WesternSBWatermasterMaps\RiversideBasinAreaSouthV04.mxd)
3/4/2010 -- 9:58:24 AM



WESTERN - SAN BERNARDINO WATERMASTER

RIVERSIDE SOUTH BASIN



RIVERSIDE BASIN AREA
IN RIVERSIDE COUNTY
CROSS INDEX BY OWNER

**WESTERN - SAN BERNARDINO WATERMASTER
VERIFIED PRODUCTION DATA
CROSS INDEX BY OWNER
RIVERSIDE SOUTH BASIN**

OWNER	WELL TYPE	RECRDTN NUMBER	STATE NUMBER	WELL LOCAL DESIGNATION	YEAR CLOSED	-----CALENDAR YEAR EXTRACTATIONS-----					
						2008	2009	2010	2011	2012	AVG
AGUA MANSA PROPERTIES, INC	W	3301081	02S/05W-14B	ANZA	1975	0	0	0	0	0	0
AGUA MANSA PROPERTIES, INC	W	3301927	02S/05W-03R03S	2	1974	0	0	0	0	0	0
ALAMO WATER COMPANY	W	3301768	02S/05W-11J			23	36	22	22	20	25
BANK OF AMERICA N.T.&S.A.	W	3301605	02S/04W-19P01S	WOODILL	1967	0	0	0	0	0	0
BOX SPRINGS MUTUAL WATER COMPANY	W	3300272	03S/04W-10A	13	1978	0	0	0	0	0	0
BOX SPRINGS MUTUAL WATER COMPANY	W	3300272-	03S/04W-10A	14	1964	0	0	0	0	0	0
BOX SPRINGS MUTUAL WATER COMPANY	W	3300273	03S/04W-10G	7	1978	0	0	0	0	0	0
BOX SPRINGS MUTUAL WATER COMPANY	W	3300273-	03S/04W-10G	15	1964	0	0	0	0	0	0
BOX SPRINGS MUTUAL WATER COMPANY	W	3300274	03S/04W-10B	8	1978	0	0	0	0	0	0
BOX SPRINGS MUTUAL WATER COMPANY	W	3300274-	03S/04W-10B	16	1989	0	0	0	0	0	0
BOX SPRINGS MUTUAL WATER COMPANY	W	3300275	03S/04W-10A	17		403	331	291	281	287	319
BURNS, F.L. & LAURA	W	3300439	02S/04W-07N	CIT ST 2	1971	0	0	0	0	0	0
CALIF BAPTIST UNIVERSITY	W	3303109	03S/05W-08B02S	IRRIGATION		77	100	100	63	53	79
CANYON CREST COUNTRY CLUB	W	3302052	02S/04W-31R01S	NO 1		27	26	25	25	25	26
CARPENTER COMPANY	W	3301036	03S/05W-09A01S	CBLNCA 1	1991	0	0	0	0	0	0
CITIZENS NATIONAL COMPANY	W	3300375	02S/05W-23L01S	AIR COND	1971	0	0	0	0	0	0
CRESTMORE HEIGHTS MUTUAL WATER COMPA	W	3301372	02S/05W-03B02S	2	1999	0	0	0	0	0	0
CRESTMORE HEIGHTS MUTUAL WATER COMPA	W	3301659	02S/05W-03B	3	1999	0	0	0	0	0	0
EASTERN MUNICIPAL WATER DISTRICT	W	3300981	03S/04W-03Q	RECHE CN	1974	0	0	0	0	0	0
EASTERN MUNICIPAL WATER DISTRICT	W	3300982	03S/04W-03R	DICKNSON	1974	0	0	0	0	0	0
EMPIRE WATER	W	3302979	02S/05W-08K05S	#2 - SCHOOL		501	427	412	386	442	434
EMPIRE WATER	W	3302980	02S/05W-08K04S	#1 - SCHOOL		74	106	63	70	61	75
GROSS, DALE P.	W	3300748	02S/05W-12E	1	1971	0	0	0	0	0	0
GRUBBS, V. W.	W	3300076	02S/04W-07P		1968	0	0	0	0	0	0
HEYMING, FRANK & LUCY	W	3303110	03S/05W-04N01S	RED BARN		0	1	13	13	13	8
HUNTER ENGINEERING COMPANY	W	3300607	02S/04W-18E01S	SMITH 1	1974	0	0	0	0	0	0
HUNTER ENGINEERING COMPANY	W	3300608	02S/04W-18F	2	1974	0	0	0	0	0	0
HUNTER ENGINEERING COMPANY	W	3300609	02S/04W-18C	3	1974	0	0	0	0	0	0
JOHNSON, TRUMAN	W	0000402	02S/05W-14E	1	1998	0	0	0	0	0	0
JOHNSON, TRUMAN	W	3300160	02S/05W-14E	1, PALMYRITA	1981	0	0	0	0	0	0
JURUPA COMMUNITY SERVICES DISTRICT	W	3301362	02S/05W-08G04S	3	2000	0	0	0	0	0	0
JURUPA COMMUNITY SERVICES DISTRICT	W	3301501	02S/05W-08G01S	SUNNYSLOPE #5		0	0	1	1	47	10
JURUPA COMMUNITY SERVICES DISTRICT	W	3301502	02S/05W-08K02S	6	1981	0	0	0	0	0	0
JURUPA COMMUNITY SERVICES DISTRICT	W	3301578	02S/05W-05R	PEARSON MUTAL	1980	0	0	0	0	0	0
JURUPA COMMUNITY SERVICES DISTRICT	W	3301625	02S/05W-08K03S	#7	1981	0	0	0	0	0	0
JURUPA COMMUNITY SERVICES DISTRICT	W	3302911	02S/05W-08G05S	#21		603	581	401	508	485	516
LA CASA CONTENTA MOTEL	W	3300573	02S/04W-19P	ADLINE	1967	0	0	0	0	0	0

**WESTERN - SAN BERNARDINO WATERMASTER
VERIFIED PRODUCTION DATA
CROSS INDEX BY OWNER
RIVERSIDE SOUTH BASIN**

OWNER	WELL TYPE	RECRDTN NUMBER	STATE WELL NUMBER	LOCAL DESIGNATION	YEAR CLOSED	-----CALENDAR YEAR EXTRACTATIONS-----						AVG
						2008	2009	2010	2011	2012		
LORING RANCH 31503 LP	W	3300601	02S/05W-22D01S	"G" (JONES RANCH)		0	0	0	0	0	0	0
MADISON, ERIN	W	3301203	02S/05W-02F	1 VALENCIA	1989	0	0	0	0	0	0	0
MADISON, ERIN	W	3301473	02S/05W-02F	CHINO NO 3	1989	0	0	0	0	0	0	0
MADISON, ERIN	W	3301626-	02S/05W-02L	64-1	1989	0	0	0	0	0	0	0
MARTIN LINEN (TRI-CITY LINEN SUPPLY CO)	W	3301384	02S/05W-22R01S	RIV LDYR/BLUE SEAL		88	77	64	71	55	71	
MARTIN, KENNETH ALLAN	W	3300554	02S/05W-32B01S	RR 1/NICHOLS PARK	1968	0	0	0	0	0	0	0
MASTERCRAFT HOMES	W	3300597	02S/05W-22C02S	C	2005	0	0	0	0	0	0	0
MASTERCRAFT HOMES	W	3300599	02S/05W-21B01S	"E" (JONES RANCH)	2006	0	0	0	0	0	0	0
MASTERCRAFT HOMES	W	3300600	02S/05W-21A01S	F	1990	0	0	0	0	0	0	0
MICHAEL, C.	W	3300595	02S/05W-22C01S	OLD A	1978	0	0	0	0	0	0	0
MICHAEL, C.	W	3300595-	02S/05W-22D	A (LEEVEE)	2007	0	0	0	0	0	0	0
MIPO CORP, DBA MISSION	W	3300000	02S/05W-23G02S	6TH ST	1975	0	0	0	0	0	0	0
PROPERTY ACQUISITION COMPANY	W	3301422	02S/05W-05R02S	PATA 66	1974	0	0	0	0	0	0	0
RIVERSIDE CEMENT COMPANY	W	3300369	02S/05W-02E	CHINO NO 2	1960	0	0	0	0	0	0	0
RIVERSIDE CEMENT COMPANY	W	3300370	02S/05W-03J	CRESTMOR	1988	0	0	0	0	0	0	0
RIVERSIDE CEMENT COMPANY	W	3300372	02S/05W-03G02S	49	1960	0	0	0	0	0	0	0
RIVERSIDE CEMENT COMPANY	W	3301610	02S/05W-03A03S	60-1 BLENDING PILE		1	1	1	57	1	12	
RIVERSIDE CEMENT COMPANY	W	3301626	02S/05W-02L	53-2	1978	0	0	0	0	0	0	0
RIVERSIDE CEMENT COMPANY	W	3302605	02S/05W-03F02S	88-1		1	0	0	0	0	0	0
RIVERSIDE COUNTY FLOOD CONTROL	W	3303111	02S/05W-14D01S	IRRIGATION		1	2	2	2	1	2	
RIVERSIDE COUNTY PARKS DEPARTMENT	W	3300596	02S/05W-21K01S	HQ		20	20	20	20	20	20	20
RIVERSIDE COUNTY PARKS DEPARTMENT	W	3300598	02S/05W-21K	EDMUNDS "D"		140	140	140	175	186	156	
RIVERSIDE COUNTY PARKS DEPARTMENT	W	3302204	02S/05W-21M03S	AG WELL #2-PIC LAK 8		0	62	12	62	62	40	
RIVERSIDE COUNTY PARKS DEPARTMENT	W	3302205	02S/05W-21M01S	PIC LAK 12	1990	0	0	0	0	0	0	0
RIVERSIDE COUNTY PARKS DEPARTMENT	W	3302206	02S/05W-21M04S	PIC LAK 14		180	180	180	180	180	180	
RIVERSIDE COUNTY PARKS DEPARTMENT	W	3303129	02S/05W-21E02S	SPORTS PARK					84	84	34	
RIVERSIDE HIGHLAND WATER CO	W	3301655	02S/04W-08M01S	RN #21		0	0	0	0	0	0	0
RIVERSIDE HIGHLAND WATER CO	W	3301656	02S/04W-08M02S	RN #22		0	0	0	0	0	0	0
RIVERSIDE INDUSTRIAL PARK	W	3300330	02S/05W-11C01S	8	1974	0	0	0	0	0	0	0
RIVERSIDE THOROUGHBRED FARM	W	3301834	02S/05W-15B10S	1	1990	0	0	0	0	0	0	0
RIVERSIDE THOROUGHBRED FARM	W	3301835	02S/05W-15B11S	#2	1986	0	0	0	0	0	0	0
RIVERSIDE UNIFIED SCHOOL DISTRICT	W	3303119	02S/05W-14B01S	BEATTY ELEMENTARY		18	18	19	21	10	17	
RIVERSIDE, CITY OF	W	3300417	02S/05W-25F01S	CLEARWTR	1995	0	0	0	0	0	0	0
RIVERSIDE, CITY OF	W	3300686	02S/04W-19J01S	LEMONA 1	1974	0	0	0	0	0	0	0
RIVERSIDE, CITY OF	W	3301073	02S/05W-12K02S	TWIN SPRINGS 1&2		2,904	3,484	3,471	2,625	2,607	3,018	
RIVERSIDE, CITY OF	W	3301074	02S/05W-23J01S	MULBERRY		0	0	1,341	1,320	776	687	
RIVERSIDE, CITY OF	W	3301075	02S/05W-12B01S	GARNER #1 (T&G)		5	4	3	3	4	4	

**WESTERN - SAN BERNARDINO WATERMASTER
VERIFIED PRODUCTION DATA
CROSS INDEX BY OWNER
RIVERSIDE SOUTH BASIN**

OWNER	WELL TYPE	RECRDTN NUMBER	STATE WELL NUMBER	LOCAL DESIGNATION	YEAR CLOSED	-----CALENDAR YEAR EXTRACTIONS-----					
						2008	2009	2010	2011	2012	AVG
RIVERSIDE, CITY OF	W	3301076	02S/05W-12P01S	MOORE GRIFFITH #1		1,293	1,623	513	1,093	1,629	1,230
RIVERSIDE, CITY OF	W	3301077	02S/05W-12P02S	BRUNTON		0	0	0	0	0	0
RIVERSIDE, CITY OF	W	3301078	02S/05W-28A01S	SANITARY	1977	0	0	0	0	0	0
RIVERSIDE, CITY OF	W	3301079	02S/05W-28C01S	DAVIS	1977	0	0	0	0	0	0
RIVERSIDE, CITY OF	W	3301082	02S/05W-14G02S	FAIRMOUNT PARK #1		132	66	52	153	223	125
RIVERSIDE, CITY OF	W	3301084	02S/05W-12A01S	RUSSELL	1972	0	0	0	0	0	0
RIVERSIDE, CITY OF	D	3301086	02S/05W-14K	SPRING BROOK	1966	0	0	0	0	0	0
RIVERSIDE, CITY OF	D	3301087	02S/05W-29G	JENSEN	1977	0	0	0	0	0	0
RIVERSIDE, CITY OF	W	3301284	02S/05W-24D01S	1ST ST		869	2,337	1,573	1,082	1,611	1,494
RIVERSIDE, CITY OF	W	3301285	02S/05W-13Q01S	CUNHAM 1	1978	0	0	0	0	0	0
RIVERSIDE, CITY OF	W	3301285-	02S/05W-13Q02S	CUNHAM 2		0	0	0	0	0	0
RIVERSIDE, CITY OF	W	3301286	02S/04W-07N01S	PALMYRITA 1	1978	0	0	0	0	0	0
RIVERSIDE, CITY OF	W	3301286-	02S/04W-07N03S	PALMYRITA #2		1,826	2,755	2,043	1,948	2,791	2,273
RIVERSIDE, CITY OF	W	3301287	02S/04W-07L01S	ELECTRIC ST		2,281	3,203	2,728	3,067	1,324	2,521
RIVERSIDE, CITY OF	W	3301288	02S/05W-23R01S	FILL		1,214	1,939	1,389	1,371	1,521	1,487
RIVERSIDE, CITY OF	W	3301289	02S/05W-23Q01S	11TH ST		0	0	0	0	0	0
RIVERSIDE, CITY OF	W	3301358	02S/04W-08E01S	HIGHGROVE 1		0	0	0	0	0	0
RIVERSIDE, CITY OF	W	3301359	02S/04W-08D03S	HIGHGROVE 2	1978	0	0	0	0	0	0
RIVERSIDE, CITY OF	W	3301359-	02S/04W-08D04S	HIGHGROVE 3		0	0	0	0	0	0
RIVERSIDE, CITY OF	W	3301635	02S/05W-14G03S	MORI		0	0	0	0	0	0
RIVERSIDE, CITY OF	W	3301814	03S/05W-03F01S	ORANGE ACRES	1982	0	0	0	0	0	0
RIVERSIDE, CITY OF	W	3301851	02S/05W-14E01S	FAIRMOUNT PARK 2		37	18	11	48	49	33
RIVERSIDE, CITY OF	W	3301915	02S/05W-23Q03S	FREEWAY	1989	0	0	0	0	0	0
RIVERSIDE, CITY OF	W	3301940	03S/05W-09E01S	LINCOLN HEIGHTS	1981	0	0	0	0	0	0
RIVERSIDE, CITY OF	W	3301959	02S/05W-12B04S	GARNER B		2,268	1,992	858	1,714	1,348	1,636
RIVERSIDE, CITY OF	W	3302472	02S/05W-12C03S	GARNER C		2,911	3,533	2,254	2,209	1,572	2,496
RIVERSIDE, CITY OF	W	3302531	02S/05W-12A03S	RUSSELL B		0	0	0	0	0	0
RIVERSIDE, CITY OF	W	3302618	02S/05W-12B06S	GARNER D		2,409	2,896	1,750	1,741	792	1,918
RIVERSIDE, CITY OF	W	3302890	02S/05W-12B07S	RUSSELL C		593	0	0	0	0	119
RIVERSIDE, CITY OF-GAGE CANAL	W	3300366	02S/05W-26F01S	OLIVEWOOD 1		1,025	712	804	987	924	890
RIVERSIDE, CITY OF-GAGE CANAL	W	3300367	02S/05W-26E02S	OLIVEWOOD 2		1,260	1,281	1,144	1,361	1,295	1,268
RIVERSIDE, CITY OF-GAGE CANAL	W	3300368	02S/05W-26M01S	OLIVEWOOD 3		907	546	705	743	385	657
RIVINO WATER COMPANY	W	3301346	02S/05W-02L01S	1	1980	0	0	0	0	0	0
ROCKY R RANCH	W	3300768	03S/05W-14E	GURNEY 1	1974	0	0	0	0	0	0
ROOS, CHARLES E.	W	3301257	02S/04W-31E01S	1	1970	0	0	0	0	0	0
ROSS, SAM	W	3301194	02S/05W-12R01S	1 WEST	1959	0	0	0	0	0	0
RUBIDOUX C.S.D.	W	0000401	02S/05W-20R01S	SEWER PLANT	1999	0	0	0	0	0	0

**WESTERN - SAN BERNARDINO WATERMASTER
VERIFIED PRODUCTION DATA
CROSS INDEX BY OWNER
RIVERSIDE SOUTH BASIN**

OWNER	WELL TYPE	RECRDTN NUMBER	STATE WELL NUMBER	LOCAL DESIGNATION	YEAR CLOSED	-----CALENDAR YEAR EXTRACTIIONS-----						AVG
						2008	2009	2010	2011	2012		
RUBIDOUX C.S.D.	W	3300022	02S/05W-16R	OLD #1 (RIO RANCHO)	1978	0	0	0	0	0	0	0
RUBIDOUX C.S.D.	W	3300022-	02S/05W-16R01S	1 (RIO RANCHO)	2000	0	0	0	0	0	0	0
RUBIDOUX C.S.D.	W	3301153	02S/05W-15M02S	#7, DALY #2		1	0	0	0	1	0	0
RUBIDOUX C.S.D.	W	3301154	02S/05W-15L09S	#8, 34TH & DALY	1989	0	0	0	0	0	0	0
RUBIDOUX C.S.D.	W	3301296	02S/05W-16J	#19 1-FT FREMONT NE		27	5	3	0	0	7	7
RUBIDOUX C.S.D.	W	3301297	02S/05W-16J	#20 2-FT FREMONT SW		1	24	22	26	14	17	17
RUBIDOUX C.S.D.	W	3301363	02S/05W-16E06S	OLD #4	1988	0	0	0	0	0	0	0
RUBIDOUX C.S.D.	W	3301423	02S/05W-16G04S	NO 1	1987	0	0	0	0	0	0	0
RUBIDOUX C.S.D.	W	3301424	02S/05W-15M01S	#9, WALLACE STREET	1988	0	0	0	0	0	0	0
RUBIDOUX C.S.D.	W	3301524	02S/05W-19J	J H #9	1979	0	0	0	0	0	0	0
RUBIDOUX C.S.D.	W	3301524-	02S/05W-20J02S	#16 HUNTER	2002	0	0	0	0	0	0	0
RUBIDOUX C.S.D.	W	3301694	02S/05W-20H04S	#13 HUNTER 6		0	0	0	0	0	0	0
RUBIDOUX C.S.D.	W	3301887	02S/05W-10P01S	#3 28TH ST		0	0	0	0	0	0	0
RUBIDOUX C.S.D.	W	3301892	02S/05W-17R03S	#11 CLEMENTS (OLD 4)		373	417	85	333	378	317	317
RUBIDOUX C.S.D.	W	3302007	02S/05W-16H06S	#2, TROYER		475	817	1,052	1,305	1,331	996	996
RUBIDOUX C.S.D.	W	3302008	02S/05W-10K06S	NO 1, W RIV MUTUAL	2001	0	0	0	0	0	0	0
RUBIDOUX C.S.D.	W	3302538	02S/05W-20A01S	#14, 46TH ST		6	0	246	0	0	50	50
RUBIDOUX C.S.D.	W	3302539	02S/05W-21C01S	#12, AIRPORT	2008	0	0	0	0	0	0	0
RUBIDOUX C.S.D.	W	3302540	02S/05W-15M01S	#5 DALY #1 (NEW 36TH)		0	0	0	0	0	0	0
RUBIDOUX C.S.D.	W	3302541	02S/05W-11C02S	#4, OLD SKOTTY		747	554	567	395	327	518	518
RUBIDOUX C.S.D.	W	3302542	02S/05W-15L01S	#1-CRESTMORE	2002	0	0	0	0	0	0	0
RUBIDOUX C.S.D.	W	3302772	02S/05W-11C02S	#6, NEW SKOTTY		70	80	23	183	156	102	102
RUBIDOUX C.S.D.	W	3302810	02S/05W-15L	GOULD (NEW DALY #8)		1,259	1,345	1,547	2,030	2,021	1,640	1,640
RUBIDOUX C.S.D.	W	3302985	02S/05W-15L11S	#17 (NORTH WELL)		87	158	15	1,133	0	279	279
RUBIDOUX C.S.D.	W	3302986	02S/05W-15L12	#18 (SOUTH WELL)		3,656	3,209	2,725	1,195	2,559	2,669	2,669
SCHWAB, A. M.	W	3300230	02S/04W-08N02S	PLMYRTA	1981	0	0	0	0	0	0	0
SCOPE CORPORATION	W	3300003	02S/04W-19J02S	COOK 2	1972	0	0	0	0	0	0	0
SCOPE CORPORATION	W	3300004	02S/04W-19R01S	HALL 1	1972	0	0	0	0	0	0	0
STOKER, GEORGE	W	3300798	02S/05W-12A		1971	0	0	0	0	0	0	0
TAYLOR, WALTER & BARBARA	W	3300371	02S/05W-05K	FALCO	2000	0	0	0	0	0	0	0
UNIVERSAL FOREST PRODUCTS	W	3302233	02S/05W-10C04S	1		0	0	0	0	0	0	0
UNIVERSAL FOREST PRODUCTS	W	3302234	02S/05W-10C03S	2		0	0	0	0	0	0	0
UNIVERSAL FOREST PRODUCTS	W	3302235	02S/05W-10C01S	3		0	0	0	0	0	0	0
UNIVERSITY OF CALIFORNIA, REGENTS OF	W	3300040	02S/04W-08D02S	#8, HIGHGROVE		0	0	0	0	0	0	0
VICTORIA COUNTRY CLUB	W	3300417-	02S/05W-25F01S	CLEARWATER		0	0	0	0	0	0	0
VICTORIA COUNTRY CLUB	W	3303105	02S/05W-25F02S	#2		426	435	400	422	379	412	412
VON KANEL, ALFRED	W	3300068	02S/05W-32A01S		1979	0	0	0	0	0	0	0

**WESTERN - SAN BERNARDINO WATERMASTER
 VERIFIED PRODUCTION DATA
 CROSS INDEX BY OWNER
 RIVERSIDE SOUTH BASIN**

OWNER	WELL TYPE	RECRDTN NUMBER	STATE WELL NUMBER	LOCAL DESIGNATION	YEAR CLOSED	-----CALENDAR YEAR EXTRACTIONS-----					
						2008	2009	2010	2011	2012	AVG
WATERMAN, ALLEN H	W	3300812	02S/05W-11P	WTRMN 1	1962	0	0	0	0	0	0
WHITE SULPHUR SPRINGS POOL	W	3300754	02S/05W-13E	WHSLPHR 1	1971	0	0	0	0	0	0
WIGHT, CHARLES H	W	3300277	02S/05W-11K		1972	0	0	0	0	0	0
ZIKE, VERA	W	3300811	02S/05W-32K01S	WAYMAN	1975	0	0	0	0	0	0
TOTALS FOR 152 WELLS						31,219	35,541	29,090	30,528	28,049	30,885

RIVERSIDE BASIN AREA
IN RIVERSIDE COUNTY
CROSS INDEX BY STATE WELL NUMBER

**WESTERN - SAN BERNARDINO WATERMASTER
VERIFIED PRODUCTION DATA
CROSS INDEX BY STATE WELL NUMBER
RIVERSIDE SOUTH BASIN**

STATE WELL NUMBER	RECRDTN NUMBER	OWNER	WELL TYPE	LOCAL DESIGNATION	YEAR CLOSED	-----CALENDAR YEAR EXTRACTIONS-----					
						2008	2009	2010	2011	2012	AVG
02S/04W-07L01S	3301287	RIVERSIDE, CITY OF	W	ELECTRIC ST		2,281	3,203	2,728	3,067	1,324	2,521
02S/04W-07N	3300439	BURNS, F.L. & LAURA	W	CIT ST 2	1971	0	0	0	0	0	0
02S/04W-07N01S	3301286	RIVERSIDE, CITY OF	W	PALMYRITA 1	1978	0	0	0	0	0	0
02S/04W-07N03S	3301286-	RIVERSIDE, CITY OF	W	PALMYRITA #2		1,826	2,755	2,043	1,948	2,791	2,273
02S/04W-07P	3300076	GRUBBS, V. W.	W		1968	0	0	0	0	0	0
02S/04W-08D02S	3300040	UNIVERSITY OF CALIFORNIA, REGENTS OF	W	#8, HIGHGROVE		0	0	0	0	0	0
02S/04W-08D03S	3301359	RIVERSIDE, CITY OF	W	HIGHGROVE 2	1978	0	0	0	0	0	0
02S/04W-08D04S	3301359-	RIVERSIDE, CITY OF	W	HIGHGROVE 3		0	0	0	0	0	0
02S/04W-08E01S	3301358	RIVERSIDE, CITY OF	W	HIGHGROVE 1		0	0	0	0	0	0
02S/04W-08M01S	3301655	RIVERSIDE HIGHLAND WATER CO	W	RN #21		0	0	0	0	0	0
02S/04W-08M02S	3301656	RIVERSIDE HIGHLAND WATER CO	W	RN #22		0	0	0	0	0	0
02S/04W-08N02S	3300230	SCHWAB, A. M.	W	PLMYRTA	1981	0	0	0	0	0	0
02S/04W-18C	3300609	HUNTER ENGINEERING COMPANY	W	3	1974	0	0	0	0	0	0
02S/04W-18E01S	3300607	HUNTER ENGINEERING COMPANY	W	SMITH 1	1974	0	0	0	0	0	0
02S/04W-18F	3300608	HUNTER ENGINEERING COMPANY	W	2	1974	0	0	0	0	0	0
02S/04W-19J01S	3300686	RIVERSIDE, CITY OF	W	LEMONA 1	1974	0	0	0	0	0	0
02S/04W-19J02S	3300003	SCOPE CORPORATION	W	COOK 2	1972	0	0	0	0	0	0
02S/04W-19P	3300573	LA CASA CONTENTA MOTEL	W	ADLINE	1967	0	0	0	0	0	0
02S/04W-19P01S	3301605	BANK OF AMERICA N.T.&S.A.	W	WOODILL	1967	0	0	0	0	0	0
02S/04W-19R01S	3300004	SCOPE CORPORATION	W	HALL 1	1972	0	0	0	0	0	0
02S/04W-31E01S	3301257	ROOS, CHARLES E.	W	1	1970	0	0	0	0	0	0
02S/04W-31R01S	3302052	CANYON CREST COUNTRY CLUB	W	NO 1		27	26	25	25	25	26
02S/05W-02E	3300369	RIVERSIDE CEMENT COMPANY	W	CHINO NO 2	1960	0	0	0	0	0	0
02S/05W-02F	3301203	MADISON, ERIN	W	1 VALENCIA	1989	0	0	0	0	0	0
02S/05W-02F	3301473	MADISON, ERIN	W	CHINO NO 3	1989	0	0	0	0	0	0
02S/05W-02L	3301626	RIVERSIDE CEMENT COMPANY	W	53-2	1978	0	0	0	0	0	0
02S/05W-02L	3301626-	MADISON, ERIN	W	64-1	1989	0	0	0	0	0	0
02S/05W-02L01S	3301346	RIVINO WATER COMPANY	W	1	1980	0	0	0	0	0	0
02S/05W-03A03S	3301610	RIVERSIDE CEMENT COMPANY	W	60-1 BLENDING PILE		1	1	1	57	1	12
02S/05W-03B	3301659	CRESTMORE HEIGHTS MUTUAL WATER COMPAN	W	3	1999	0	0	0	0	0	0
02S/05W-03B02S	3301372	CRESTMORE HEIGHTS MUTUAL WATER COMPAN	W	2	1999	0	0	0	0	0	0
02S/05W-03F02S	3302605	RIVERSIDE CEMENT COMPANY	W	88-1		1	0	0	0	0	0
02S/05W-03G02S	3300372	RIVERSIDE CEMENT COMPANY	W	49	1960	0	0	0	0	0	0
02S/05W-03J	3300370	RIVERSIDE CEMENT COMPANY	W	CRESTMOR	1988	0	0	0	0	0	0
02S/05W-03R03S	3301927	AGUA MANSA PROPERTIES, INC	W	2	1974	0	0	0	0	0	0
02S/05W-05K	3300371	TAYLOR, WALTER & BARBARA	W	FALCO	2000	0	0	0	0	0	0
02S/05W-05R	3301578	JURUPA COMMUNITY SERVICES DISTRICT	W	PEARSON MUTAL	1980	0	0	0	0	0	0

**WESTERN - SAN BERNARDINO WATERMASTER
VERIFIED PRODUCTION DATA
CROSS INDEX BY STATE WELL NUMBER
RIVERSIDE SOUTH BASIN**

STATE WELL NUMBER	RECRDTN NUMBER	OWNER	WELL TYPE	LOCAL DESIGNATION	YEAR CLOSED	-----CALENDAR YEAR EXTRACTIONS-----					
						2008	2009	2010	2011	2012	AVG
02S/05W-05R02S	3301422	PROPERTY ACQUISITION COMPANY	W	PATA 66	1974	0	0	0	0	0	0
02S/05W-08G01S	3301501	JURUPA COMMUNITY SERVICES DISTRICT	W	SUNNYSLOPE #5		0	0	1	1	47	10
02S/05W-08G04S	3301362	JURUPA COMMUNITY SERVICES DISTRICT	W	3	2000	0	0	0	0	0	0
02S/05W-08G05S	3302911	JURUPA COMMUNITY SERVICES DISTRICT	W	#21		603	581	401	508	485	516
02S/05W-08K02S	3301502	JURUPA COMMUNITY SERVICES DISTRICT	W	6	1981	0	0	0	0	0	0
02S/05W-08K03S	3301625	JURUPA COMMUNITY SERVICES DISTRICT	W	#7	1981	0	0	0	0	0	0
02S/05W-08K04S	3302980	EMPIRE WATER	W	#1 - SCHOOL		74	106	63	70	61	75
02S/05W-08K05S	3302979	EMPIRE WATER	W	#2 - SCHOOL		501	427	412	386	442	434
02S/05W-10C01S	3302235	UNIVERSAL FOREST PRODUCTS	W	3		0	0	0	0	0	0
02S/05W-10C03S	3302234	UNIVERSAL FOREST PRODUCTS	W	2		0	0	0	0	0	0
02S/05W-10C04S	3302233	UNIVERSAL FOREST PRODUCTS	W	1		0	0	0	0	0	0
02S/05W-10K06S	3302008	RUBIDOUX C.S.D.	W	NO 1, W RIV MUTUAL	2001	0	0	0	0	0	0
02S/05W-10P01S	3301887	RUBIDOUX C.S.D.	W	#3 28TH ST		0	0	0	0	0	0
02S/05W-11C01S	3300330	RIVERSIDE INDUSTRIAL PARK	W	8	1974	0	0	0	0	0	0
02S/05W-11C02S	3302541	RUBIDOUX C.S.D.	W	#4, OLD SKOTTY		747	554	567	395	327	518
02S/05W-11C02S	3302772	RUBIDOUX C.S.D.	W	#6, NEW SKOTTY		70	80	23	183	156	102
02S/05W-11J	3301768	ALAMO WATER COMPANY	W			23	36	22	22	20	25
02S/05W-11K	3300277	WIGHT, CHARLES H	W		1972	0	0	0	0	0	0
02S/05W-11P	3300812	WATERMAN, ALLEN H	W	WTRMN 1	1962	0	0	0	0	0	0
02S/05W-12A	3300798	STOKER, GEORGE	W		1971	0	0	0	0	0	0
02S/05W-12A01S	3301084	RIVERSIDE, CITY OF	W	RUSSELL	1972	0	0	0	0	0	0
02S/05W-12A03S	3302531	RIVERSIDE, CITY OF	W	RUSSELL B		0	0	0	0	0	0
02S/05W-12B01S	3301075	RIVERSIDE, CITY OF	W	GARNER #1 (T&G)		5	4	3	3	4	4
02S/05W-12B04S	3301959	RIVERSIDE, CITY OF	W	GARNER B		2,268	1,992	858	1,714	1,348	1,636
02S/05W-12B06S	3302618	RIVERSIDE, CITY OF	W	GARNER D		2,409	2,896	1,750	1,741	792	1,918
02S/05W-12B07S	3302890	RIVERSIDE, CITY OF	W	RUSSELL C		593	0	0	0	0	119
02S/05W-12C03S	3302472	RIVERSIDE, CITY OF	W	GARNER C		2,911	3,533	2,254	2,209	1,572	2,496
02S/05W-12E	3300748	GROSS, DALE P.	W	1	1971	0	0	0	0	0	0
02S/05W-12K02S	3301073	RIVERSIDE, CITY OF	W	TWIN SPRINGS 1&2		2,904	3,484	3,471	2,625	2,607	3,018
02S/05W-12P01S	3301076	RIVERSIDE, CITY OF	W	MOORE GRIFFITH #1		1,293	1,623	513	1,093	1,629	1,230
02S/05W-12P02S	3301077	RIVERSIDE, CITY OF	W	BRUNTON		0	0	0	0	0	0
02S/05W-12R01S	3301194	ROSS, SAM	W	1 WEST	1959	0	0	0	0	0	0
02S/05W-13E	3300754	WHITE SULPHUR SPRINGS POOL	W	WHSLPHR 1	1971	0	0	0	0	0	0
02S/05W-13Q01S	3301285	RIVERSIDE, CITY OF	W	CUNHAM 1	1978	0	0	0	0	0	0
02S/05W-13Q02S	3301285-	RIVERSIDE, CITY OF	W	CUNHAM 2		0	0	0	0	0	0
02S/05W-14B	3301081	AGUA MANSA PROPERTIES, INC	W	ANZA	1975	0	0	0	0	0	0
02S/05W-14B01S	3303119	RIVERSIDE UNIFIED SCHOOL DISTRICT	W	BEATTY ELEMENTARY		18	18	19	21	10	17

**WESTERN - SAN BERNARDINO WATERMASTER
VERIFIED PRODUCTION DATA
CROSS INDEX BY STATE WELL NUMBER
RIVERSIDE SOUTH BASIN**

STATE WELL NUMBER	RECRDTN NUMBER	OWNER	WELL TYPE	LOCAL DESIGNATION	YEAR CLOSED	-----CALENDAR YEAR EXTRACTIONS-----					
						2008	2009	2010	2011	2012	AVG
02S/05W-14D01S	3303111	RIVERSIDE COUNTY FLOOD CONTROL	W	IRRIGATION		1	2	2	2	1	2
02S/05W-14E	0000402	JOHNSON, TRUMAN	W	1	1998	0	0	0	0	0	0
02S/05W-14E	3300160	JOHNSON, TRUMAN	W	1, PALMYRITA	1981	0	0	0	0	0	0
02S/05W-14E01S	3301851	RIVERSIDE, CITY OF	W	FAIRMOUNT PARK 2		37	18	11	48	49	33
02S/05W-14G02S	3301082	RIVERSIDE, CITY OF	W	FAIRMOUNT PARK #1		132	66	52	153	223	125
02S/05W-14G03S	3301635	RIVERSIDE, CITY OF	W	MORI		0	0	0	0	0	0
02S/05W-14K	3301086	RIVERSIDE, CITY OF	D	SPRING BROOK	1966	0	0	0	0	0	0
02S/05W-15B10S	3301834	RIVERSIDE THOROUGHbred FARM	W	1	1990	0	0	0	0	0	0
02S/05W-15B11S	3301835	RIVERSIDE THOROUGHbred FARM	W	#2	1986	0	0	0	0	0	0
02S/05W-15L	3302810	RUBIDOUX C.S.D.	W	GOULD (NEW DALY #8)		1,259	1,345	1,547	2,030	2,021	1,640
02S/05W-15L01S	3302542	RUBIDOUX C.S.D.	W	#1-CRESTMORE	2002	0	0	0	0	0	0
02S/05W-15L09S	3301154	RUBIDOUX C.S.D.	W	#8, 34TH & DALY	1989	0	0	0	0	0	0
02S/05W-15L11S	3302985	RUBIDOUX C.S.D.	W	#17 (NORTH WELL)		87	158	15	1,133	0	279
02S/05W-15L12	3302986	RUBIDOUX C.S.D.	W	#18 (SOUTH WELL)		3,656	3,209	2,725	1,195	2,559	2,669
02S/05W-15M01S	3301424	RUBIDOUX C.S.D.	W	#9, WALLACE STREET	1988	0	0	0	0	0	0
02S/05W-15M01S	3302540	RUBIDOUX C.S.D.	W	#5 DALY #1(NEW 36TH)		0	0	0	0	0	0
02S/05W-15M02S	3301153	RUBIDOUX C.S.D.	W	#7, DALY #2		1	0	0	0	1	0
02S/05W-16E06S	3301363	RUBIDOUX C.S.D.	W	OLD #4	1988	0	0	0	0	0	0
02S/05W-16G04S	3301423	RUBIDOUX C.S.D.	W	NO 1	1987	0	0	0	0	0	0
02S/05W-16H06S	3302007	RUBIDOUX C.S.D.	W	#2, TROYER		475	817	1,052	1,305	1,331	996
02S/05W-16J	3301296	RUBIDOUX C.S.D.	W	#19 1-FT FREMONT NE		27	5	3	0	0	7
02S/05W-16J	3301297	RUBIDOUX C.S.D.	W	#20 2-FT FREMONT SW		1	24	22	26	14	17
02S/05W-16R	3300022	RUBIDOUX C.S.D.	W	OLD #1 (RIO RANCHO)	1978	0	0	0	0	0	0
02S/05W-16R01S	3300022-	RUBIDOUX C.S.D.	W	1 (RIO RANCHO)	2000	0	0	0	0	0	0
02S/05W-17R03S	3301892	RUBIDOUX C.S.D.	W	#11 CLEMENTS (OLD 4)		373	417	85	333	378	317
02S/05W-19J	3301524	RUBIDOUX C.S.D.	W	J H #9	1979	0	0	0	0	0	0
02S/05W-20A01S	3302538	RUBIDOUX C.S.D.	W	#14, 46TH ST		6	0	246	0	0	50
02S/05W-20H04S	3301694	RUBIDOUX C.S.D.	W	#13 HUNTER 6		0	0	0	0	0	0
02S/05W-20J02S	3301524-	RUBIDOUX C.S.D.	W	#16 HUNTER	2002	0	0	0	0	0	0
02S/05W-20R01S	0000401	RUBIDOUX C.S.D.	W	SEWER PLANT	1999	0	0	0	0	0	0
02S/05W-21A01S	3300600	MASTERCRAFT HOMES	W	F	1990	0	0	0	0	0	0
02S/05W-21B01S	3300599	MASTERCRAFT HOMES	W	"E" (JONES RANCH)	2006	0	0	0	0	0	0
02S/05W-21C01S	3302539	RUBIDOUX C.S.D.	W	#12, AIRPORT	2008	0	0	0	0	0	0
02S/05W-21E02S	3303129	RIVERSIDE COUNTY PARKS DEPARTMENT	W	SPORTS PARK					84	84	34
02S/05W-21K	3300598	RIVERSIDE COUNTY PARKS DEPARTMENT	W	EDMUNDS "D"		140	140	140	175	186	156
02S/05W-21K01S	3300596	RIVERSIDE COUNTY PARKS DEPARTMENT	W	HQ		20	20	20	20	20	20
02S/05W-21M01S	3302205	RIVERSIDE COUNTY PARKS DEPARTMENT	W	PIC LAK 12	1990	0	0	0	0	0	0

**WESTERN - SAN BERNARDINO WATERMASTER
VERIFIED PRODUCTION DATA
CROSS INDEX BY STATE WELL NUMBER
RIVERSIDE SOUTH BASIN**

STATE WELL NUMBER	RECRDTN NUMBER	OWNER	WELL TYPE	LOCAL DESIGNATION	YEAR CLOSED	-----CALENDAR YEAR EXTRACTIONS-----					
						2008	2009	2010	2011	2012	AVG
02S/05W-21M03S	3302204	RIVERSIDE COUNTY PARKS DEPARTMENT	W	AG WELL #2-PIC LAK 8		0	62	12	62	62	40
02S/05W-21M04S	3302206	RIVERSIDE COUNTY PARKS DEPARTMENT	W	PIC LAK 14		180	180	180	180	180	180
02S/05W-22C01S	3300595	MICHAEL, C.	W	OLD A	1978	0	0	0	0	0	0
02S/05W-22C02S	3300597	MASTERCRAFT HOMES	W	C	2005	0	0	0	0	0	0
02S/05W-22D	3300595-	MICHAEL, C.	W	A (LEEVEE)	2007	0	0	0	0	0	0
02S/05W-22D01S	3300601	LORING RANCH 31503 LP	W	"G" (JONES RANCH)		0	0	0	0	0	0
02S/05W-22R01S	3301384	MARTIN LINEN (TRI-CITY LINEN SUPPLY CO)	W	RIV LDRY/BLUE SEAL		88	77	64	71	55	71
02S/05W-23G02S	3300000	MIPO CORP, DBA MISSION	W	6TH ST	1975	0	0	0	0	0	0
02S/05W-23J01S	3301074	RIVERSIDE, CITY OF	W	MULBERRY		0	0	1,341	1,320	776	687
02S/05W-23L01S	3300375	CITIZENS NATIONAL COMPANY	W	AIR COND	1971	0	0	0	0	0	0
02S/05W-23Q01S	3301289	RIVERSIDE, CITY OF	W	11TH ST		0	0	0	0	0	0
02S/05W-23Q03S	3301915	RIVERSIDE, CITY OF	W	FREEWAY	1989	0	0	0	0	0	0
02S/05W-23R01S	3301288	RIVERSIDE, CITY OF	W	FILL		1,214	1,939	1,389	1,371	1,521	1,487
02S/05W-24D01S	3301284	RIVERSIDE, CITY OF	W	1ST ST		869	2,337	1,573	1,082	1,611	1,494
02S/05W-25F01S	3300417	RIVERSIDE, CITY OF	W	CLEARWTR	1995	0	0	0	0	0	0
02S/05W-25F01S	3300417-	VICTORIA COUNTRY CLUB	W	CLEARWATER		0	0	0	0	0	0
02S/05W-25F02S	3303105	VICTORIA COUNTRY CLUB	W	#2		426	435	400	422	379	412
02S/05W-26E02S	3300367	RIVERSIDE, CITY OF-GAGE CANAL	W	OLIVEWOOD 2		1,260	1,281	1,144	1,361	1,295	1,268
02S/05W-26F01S	3300366	RIVERSIDE, CITY OF-GAGE CANAL	W	OLIVEWOOD 1		1,025	712	804	987	924	890
02S/05W-26M01S	3300368	RIVERSIDE, CITY OF-GAGE CANAL	W	OLIVEWOOD 3		907	546	705	743	385	657
02S/05W-28A01S	3301078	RIVERSIDE, CITY OF	W	SANITARY	1977	0	0	0	0	0	0
02S/05W-28C01S	3301079	RIVERSIDE, CITY OF	W	DAVIS	1977	0	0	0	0	0	0
02S/05W-29G	3301087	RIVERSIDE, CITY OF	D	JENSEN	1977	0	0	0	0	0	0
02S/05W-32A01S	3300068	VON KANEL, ALFRED	W		1979	0	0	0	0	0	0
02S/05W-32B01S	3300554	MARTIN, KENNETH ALLAN	W	RR 1/NICHOLS PARK	1968	0	0	0	0	0	0
02S/05W-32K01S	3300811	ZIKE, VERA	W	WAYMAN	1975	0	0	0	0	0	0
03S/04W-03Q	3300981	EASTERN MUNICIPAL WATER DISTRICT	W	RECHE CN	1974	0	0	0	0	0	0
03S/04W-03R	3300982	EASTERN MUNICIPAL WATER DISTRICT	W	DICKNSON	1974	0	0	0	0	0	0
03S/04W-10A	3300272	BOX SPRINGS MUTUAL WATER COMPANY	W	13	1978	0	0	0	0	0	0
03S/04W-10A	3300272-	BOX SPRINGS MUTUAL WATER COMPANY	W	14	1964	0	0	0	0	0	0
03S/04W-10A	3300275	BOX SPRINGS MUTUAL WATER COMPANY	W	17		403	331	291	281	287	319
03S/04W-10B	3300274	BOX SPRINGS MUTUAL WATER COMPANY	W	8	1978	0	0	0	0	0	0
03S/04W-10B	3300274-	BOX SPRINGS MUTUAL WATER COMPANY	W	16	1989	0	0	0	0	0	0
03S/04W-10G	3300273	BOX SPRINGS MUTUAL WATER COMPANY	W	7	1978	0	0	0	0	0	0
03S/04W-10G	3300273-	BOX SPRINGS MUTUAL WATER COMPANY	W	15	1964	0	0	0	0	0	0
03S/05W-03F01S	3301814	RIVERSIDE, CITY OF	W	ORANGE ACRES	1982	0	0	0	0	0	0
03S/05W-04N01S	3303110	HEYMING, FRANK & LUCY	W	RED BARN		0	1	13	13	13	8

**WESTERN - SAN BERNARDINO WATERMASTER
 VERIFIED PRODUCTION DATA
 CROSS INDEX BY STATE WELL NUMBER
 RIVERSIDE SOUTH BASIN**

STATE WELL NUMBER	RECRDTN NUMBER	OWNER	WELL TYPE	LOCAL DESIGNATION	YEAR CLOSED	-----CALENDAR YEAR EXTRACTIONS-----					
						2008	2009	2010	2011	2012	AVG
03S/05W-08B02S	3303109	CALIF BAPTIST UNIVERSITY	W	IRRIGATION		77	100	100	63	53	79
03S/05W-09A01S	3301036	CARPENTER COMPANY	W	CBLNCA 1	1991	0	0	0	0	0	0
03S/05W-09E01S	3301940	RIVERSIDE, CITY OF	W	LINCOLN HEIGHTS	1981	0	0	0	0	0	0
03S/05W-14E	3300768	ROCKY R RANCH	W	GURNEY 1	1974	0	0	0	0	0	0
TOTALS FOR 152 WELLS						31,219	35,541	29,090	30,528	28,049	30,885

RIVERSIDE BASIN AREA
IN RIVERSIDE COUNTY
CROSS INDEX BY RECORDATION NUMBER

**WESTERN - SAN BERNARDINO WATERMASTER
VERIFIED PRODUCTION DATA
CROSS INDEX BY RECORDATION NUMBER
RIVERSIDE SOUTH BASIN**

RECRDTN NUMBER	STATE WELL NUMBER	WELL OWNER	WELL TYPE	LOCAL DESIGNATION	YEAR CLOSED	-----CALENDAR YEAR EXTRACTIONS-----					
						2008	2009	2010	2011	2012	AVG
0000401	02S/05W-20R01S	RUBIDOUX C.S.D.	W	SEWER PLANT	1999	0	0	0	0	0	0
0000402	02S/05W-14E	JOHNSON, TRUMAN	W	1	1998	0	0	0	0	0	0
3300000	02S/05W-23G02S	MIPO CORP, DBA MISSION	W	6TH ST	1975	0	0	0	0	0	0
3300003	02S/04W-19J02S	SCOPE CORPORATION	W	COOK 2	1972	0	0	0	0	0	0
3300004	02S/04W-19R01S	SCOPE CORPORATION	W	HALL 1	1972	0	0	0	0	0	0
3300022	02S/05W-16R	RUBIDOUX C.S.D.	W	OLD #1 (RIO RANCHO)	1978	0	0	0	0	0	0
3300022-	02S/05W-16R01S	RUBIDOUX C.S.D.	W	1 (RIO RANCHO)	2000	0	0	0	0	0	0
3300040	02S/04W-08D02S	UNIVERSITY OF CALIFORNIA, REGENTS OF	W	#8, HIGHGROVE		0	0	0	0	0	0
3300068	02S/05W-32A01S	VON KANEL, ALFRED	W		1979	0	0	0	0	0	0
3300076	02S/04W-07P	GRUBBS, V. W.	W		1968	0	0	0	0	0	0
3300160	02S/05W-14E	JOHNSON, TRUMAN	W	1, PALMYRITA	1981	0	0	0	0	0	0
3300230	02S/04W-08N02S	SCHWAB, A. M.	W	PLMYRITA	1981	0	0	0	0	0	0
3300272	03S/04W-10A	BOX SPRINGS MUTUAL WATER COMPANY	W	13	1978	0	0	0	0	0	0
3300272-	03S/04W-10A	BOX SPRINGS MUTUAL WATER COMPANY	W	14	1964	0	0	0	0	0	0
3300273	03S/04W-10G	BOX SPRINGS MUTUAL WATER COMPANY	W	7	1978	0	0	0	0	0	0
3300273-	03S/04W-10G	BOX SPRINGS MUTUAL WATER COMPANY	W	15	1964	0	0	0	0	0	0
3300274	03S/04W-10B	BOX SPRINGS MUTUAL WATER COMPANY	W	8	1978	0	0	0	0	0	0
3300274-	03S/04W-10B	BOX SPRINGS MUTUAL WATER COMPANY	W	16	1989	0	0	0	0	0	0
3300275	03S/04W-10A	BOX SPRINGS MUTUAL WATER COMPANY	W	17		403	331	291	281	287	319
3300277	02S/05W-11K	WIGHT, CHARLES H	W		1972	0	0	0	0	0	0
3300330	02S/05W-11C01S	RIVERSIDE INDUSTRIAL PARK	W	8	1974	0	0	0	0	0	0
3300366	02S/05W-26F01S	RIVERSIDE, CITY OF-GAGE CANAL	W	OLIVEWOOD 1		1,025	712	804	987	924	890
3300367	02S/05W-26E02S	RIVERSIDE, CITY OF-GAGE CANAL	W	OLIVEWOOD 2		1,260	1,281	1,144	1,361	1,295	1,268
3300368	02S/05W-26M01S	RIVERSIDE, CITY OF-GAGE CANAL	W	OLIVEWOOD 3		907	546	705	743	385	657
3300369	02S/05W-02E	RIVERSIDE CEMENT COMPANY	W	CHINO NO 2	1960	0	0	0	0	0	0
3300370	02S/05W-03J	RIVERSIDE CEMENT COMPANY	W	CRESTMOR	1988	0	0	0	0	0	0
3300371	02S/05W-05K	TAYLOR, WALTER & BARBARA	W	FALCO	2000	0	0	0	0	0	0
3300372	02S/05W-03G02S	RIVERSIDE CEMENT COMPANY	W	49	1960	0	0	0	0	0	0
3300375	02S/05W-23L01S	CITIZENS NATIONAL COMPANY	W	AIR COND	1971	0	0	0	0	0	0
3300417	02S/05W-25F01S	RIVERSIDE, CITY OF	W	CLEARWTR	1995	0	0	0	0	0	0
3300417-	02S/05W-25F01S	VICTORIA COUNTRY CLUB	W	CLEARWATER		0	0	0	0	0	0
3300439	02S/04W-07N	BURNS, F.L. & LAURA	W	CIT ST 2	1971	0	0	0	0	0	0
3300554	02S/05W-32B01S	MARTIN, KENNETH ALLAN	W	RR 1/NICHOLS PARK	1968	0	0	0	0	0	0
3300573	02S/04W-19P	LA CASA CONTENTA MOTEL	W	ADLINE	1967	0	0	0	0	0	0
3300595	02S/05W-22C01S	MICHAEL, C.	W	OLD A	1978	0	0	0	0	0	0

**WESTERN - SAN BERNARDINO WATERMASTER
VERIFIED PRODUCTION DATA
CROSS INDEX BY RECORDATION NUMBER
RIVERSIDE SOUTH BASIN**

RECRDTN NUMBER	STATE WELL NUMBER	WELL OWNER	WELL TYPE	LOCAL DESIGNATION	YEAR CLOSED	-----CALENDAR YEAR EXTRACTIONS-----					
						2008	2009	2010	2011	2012	AVG
3300595-	02S/05W-22D	MICHAEL, C.	W	A (LEEVEE)	2007	0	0	0	0	0	0
3300596	02S/05W-21K01S	RIVERSIDE COUNTY PARKS DEPARTMENT	W	HQ		20	20	20	20	20	20
3300597	02S/05W-22C02S	MASTERCRAFT HOMES	W	C	2005	0	0	0	0	0	0
3300598	02S/05W-21K	RIVERSIDE COUNTY PARKS DEPARTMENT	W	EDMUNDS "D"		140	140	140	175	186	156
3300599	02S/05W-21B01S	MASTERCRAFT HOMES	W	"E" (JONES RANCH)	2006	0	0	0	0	0	0
3300600	02S/05W-21A01S	MASTERCRAFT HOMES	W	F	1990	0	0	0	0	0	0
3300601	02S/05W-22D01S	LORING RANCH 31503 LP	W	"G" (JONES RANCH)		0	0	0	0	0	0
3300607	02S/04W-18E01S	HUNTER ENGINEERING COMPANY	W	SMITH 1	1974	0	0	0	0	0	0
3300608	02S/04W-18F	HUNTER ENGINEERING COMPANY	W	2	1974	0	0	0	0	0	0
3300609	02S/04W-18C	HUNTER ENGINEERING COMPANY	W	3	1974	0	0	0	0	0	0
3300686	02S/04W-19J01S	RIVERSIDE, CITY OF	W	LEMONA 1	1974	0	0	0	0	0	0
3300748	02S/05W-12E	GROSS, DALE P.	W	1	1971	0	0	0	0	0	0
3300754	02S/05W-13E	WHITE SULPHUR SPRINGS POOL	W	WHSPLHR 1	1971	0	0	0	0	0	0
3300768	03S/05W-14E	ROCKY R RANCH	W	GURNEY 1	1974	0	0	0	0	0	0
3300798	02S/05W-12A	STOKER, GEORGE	W		1971	0	0	0	0	0	0
3300811	02S/05W-32K01S	ZIKE, VERA	W	WAYMAN	1975	0	0	0	0	0	0
3300812	02S/05W-11P	WATERMAN, ALLEN H	W	WTRMN 1	1962	0	0	0	0	0	0
3300981	03S/04W-03Q	EASTERN MUNICIPAL WATER DISTRICT	W	RECHE CN	1974	0	0	0	0	0	0
3300982	03S/04W-03R	EASTERN MUNICIPAL WATER DISTRICT	W	DICKNSON	1974	0	0	0	0	0	0
3301036	03S/05W-09A01S	CARPENTER COMPANY	W	CBLNCA 1	1991	0	0	0	0	0	0
3301073	02S/05W-12K02S	RIVERSIDE, CITY OF	W	TWIN SPRINGS 1&2		2,904	3,484	3,471	2,625	2,607	3,018
3301074	02S/05W-23J01S	RIVERSIDE, CITY OF	W	MULBERRY		0	0	1,341	1,320	776	687
3301075	02S/05W-12B01S	RIVERSIDE, CITY OF	W	GARNER #1 (T&G)		5	4	3	3	4	4
3301076	02S/05W-12P01S	RIVERSIDE, CITY OF	W	MOORE GRIFFITH #1		1,293	1,623	513	1,093	1,629	1,230
3301077	02S/05W-12P02S	RIVERSIDE, CITY OF	W	BRUNTON		0	0	0	0	0	0
3301078	02S/05W-28A01S	RIVERSIDE, CITY OF	W	SANITARY	1977	0	0	0	0	0	0
3301079	02S/05W-28C01S	RIVERSIDE, CITY OF	W	DAVIS	1977	0	0	0	0	0	0
3301081	02S/05W-14B	AGUA MANSA PROPERTIES, INC	W	ANZA	1975	0	0	0	0	0	0
3301082	02S/05W-14G02S	RIVERSIDE, CITY OF	W	FAIRMOUNT PARK #1		132	66	52	153	223	125
3301084	02S/05W-12A01S	RIVERSIDE, CITY OF	W	RUSSELL	1972	0	0	0	0	0	0
3301086	02S/05W-14K	RIVERSIDE, CITY OF	D	SPRING BROOK	1966	0	0	0	0	0	0
3301087	02S/05W-29G	RIVERSIDE, CITY OF	D	JENSEN	1977	0	0	0	0	0	0
3301153	02S/05W-15M02S	RUBIDOUX C.S.D.	W	#7, DALY #2		1	0	0	0	1	0
3301154	02S/05W-15L09S	RUBIDOUX C.S.D.	W	#8, 34TH & DALY	1989	0	0	0	0	0	0
3301194	02S/05W-12R01S	ROSS, SAM	W	1 WEST	1959	0	0	0	0	0	0

**WESTERN - SAN BERNARDINO WATERMASTER
VERIFIED PRODUCTION DATA
CROSS INDEX BY RECORDATION NUMBER
RIVERSIDE SOUTH BASIN**

RECRDTN NUMBER	STATE WELL NUMBER	WELL OWNER	WELL TYPE	LOCAL DESIGNATION	YEAR CLOSED	-----CALENDAR YEAR EXTRACTIONS-----					
						2008	2009	2010	2011	2012	AVG
3301203	02S/05W-02F	MADISON, ERIN	W	1 VALENCIA	1989	0	0	0	0	0	0
3301257	02S/04W-31E01S	ROOS, CHARLES E.	W	1	1970	0	0	0	0	0	0
3301284	02S/05W-24D01S	RIVERSIDE, CITY OF	W	1ST ST		869	2,337	1,573	1,082	1,611	1,494
3301285	02S/05W-13Q01S	RIVERSIDE, CITY OF	W	CUNHAM 1	1978	0	0	0	0	0	0
3301285-	02S/05W-13Q02S	RIVERSIDE, CITY OF	W	CUNHAM 2		0	0	0	0	0	0
3301286	02S/04W-07N01S	RIVERSIDE, CITY OF	W	PALMYRITA 1	1978	0	0	0	0	0	0
3301286-	02S/04W-07N03S	RIVERSIDE, CITY OF	W	PALMYRITA #2		1,826	2,755	2,043	1,948	2,791	2,273
3301287	02S/04W-07L01S	RIVERSIDE, CITY OF	W	ELECTRIC ST		2,281	3,203	2,728	3,067	1,324	2,521
3301288	02S/05W-23R01S	RIVERSIDE, CITY OF	W	FILL		1,214	1,939	1,389	1,371	1,521	1,487
3301289	02S/05W-23Q01S	RIVERSIDE, CITY OF	W	11TH ST		0	0	0	0	0	0
3301296	02S/05W-16J	RUBIDOUX C.S.D.	W	#19 1-FT FREMONT NE		27	5	3	0	0	7
3301297	02S/05W-16J	RUBIDOUX C.S.D.	W	#20 2-FT FREMONT SW		1	24	22	26	14	17
3301346	02S/05W-02L01S	RIVINO WATER COMPANY	W	1	1980	0	0	0	0	0	0
3301358	02S/04W-08E01S	RIVERSIDE, CITY OF	W	HIGHGROVE 1		0	0	0	0	0	0
3301359	02S/04W-08D03S	RIVERSIDE, CITY OF	W	HIGHGROVE 2	1978	0	0	0	0	0	0
3301359-	02S/04W-08D04S	RIVERSIDE, CITY OF	W	HIGHGROVE 3		0	0	0	0	0	0
3301362	02S/05W-08G04S	JURUPA COMMUNITY SERVICES DISTRICT	W	3	2000	0	0	0	0	0	0
3301363	02S/05W-16E06S	RUBIDOUX C.S.D.	W	OLD #4	1988	0	0	0	0	0	0
3301372	02S/05W-03B02S	CRESTMORE HEIGHTS MUTUAL WATER COMPAN	W	2	1999	0	0	0	0	0	0
3301384	02S/05W-22R01S	MARTIN LINEN (TRI-CITY LINEN SUPPLY CO)	W	RIV LDYR/BLUE SEAL		88	77	64	71	55	71
3301422	02S/05W-05R02S	PROPERTY ACQUISITION COMPANY	W	PATA 66	1974	0	0	0	0	0	0
3301423	02S/05W-16G04S	RUBIDOUX C.S.D.	W	NO 1	1987	0	0	0	0	0	0
3301424	02S/05W-15M01S	RUBIDOUX C.S.D.	W	#9, WALLACE STREET	1988	0	0	0	0	0	0
3301473	02S/05W-02F	MADISON, ERIN	W	CHINO NO 3	1989	0	0	0	0	0	0
3301501	02S/05W-08G01S	JURUPA COMMUNITY SERVICES DISTRICT	W	SUNNYSLOPE #5		0	0	1	1	47	10
3301502	02S/05W-08K02S	JURUPA COMMUNITY SERVICES DISTRICT	W	6	1981	0	0	0	0	0	0
3301524	02S/05W-19J	RUBIDOUX C.S.D.	W	J H #9	1979	0	0	0	0	0	0
3301524-	02S/05W-20J02S	RUBIDOUX C.S.D.	W	#16 HUNTER	2002	0	0	0	0	0	0
3301578	02S/05W-05R	JURUPA COMMUNITY SERVICES DISTRICT	W	PEARSON MUTAL	1980	0	0	0	0	0	0
3301605	02S/04W-19P01S	BANK OF AMERICA N.T.&S.A.	W	WOODILL	1967	0	0	0	0	0	0
3301610	02S/05W-03A03S	RIVERSIDE CEMENT COMPANY	W	60-1 BLENDING PILE		1	1	1	57	1	12
3301625	02S/05W-08K03S	JURUPA COMMUNITY SERVICES DISTRICT	W	#7	1981	0	0	0	0	0	0
3301626	02S/05W-02L	RIVERSIDE CEMENT COMPANY	W	53-2	1978	0	0	0	0	0	0
3301626-	02S/05W-02L	MADISON, ERIN	W	64-1	1989	0	0	0	0	0	0
3301635	02S/05W-14G03S	RIVERSIDE, CITY OF	W	MORI		0	0	0	0	0	0

**WESTERN - SAN BERNARDINO WATERMASTER
VERIFIED PRODUCTION DATA
CROSS INDEX BY RECORDATION NUMBER
RIVERSIDE SOUTH BASIN**

RECRDTN NUMBER	STATE WELL NUMBER	WELL OWNER	WELL TYPE	LOCAL DESIGNATION	YEAR CLOSED	-----CALENDAR YEAR EXTRACTIONS-----					
						2008	2009	2010	2011	2012	AVG
3301655	02S/04W-08M01S	RIVERSIDE HIGHLAND WATER CO	W	RN #21		0	0	0	0	0	0
3301656	02S/04W-08M02S	RIVERSIDE HIGHLAND WATER CO	W	RN #22		0	0	0	0	0	0
3301659	02S/05W-03B	CRESTMORE HEIGHTS MUTUAL WATER COMPAN	W	3	1999	0	0	0	0	0	0
3301694	02S/05W-20H04S	RUBIDOUX C.S.D.	W	#13 HUNTER 6		0	0	0	0	0	0
3301768	02S/05W-11J	ALAMO WATER COMPANY	W			23	36	22	22	20	25
3301814	03S/05W-03F01S	RIVERSIDE, CITY OF	W	ORANGE ACRES	1982	0	0	0	0	0	0
3301834	02S/05W-15B10S	RIVERSIDE THOROUGHbred FARM	W	1	1990	0	0	0	0	0	0
3301835	02S/05W-15B11S	RIVERSIDE THOROUGHbred FARM	W	#2	1986	0	0	0	0	0	0
3301851	02S/05W-14E01S	RIVERSIDE, CITY OF	W	FAIRMOUNT PARK 2		37	18	11	48	49	33
3301887	02S/05W-10P01S	RUBIDOUX C.S.D.	W	#3 28TH ST		0	0	0	0	0	0
3301892	02S/05W-17R03S	RUBIDOUX C.S.D.	W	#11 CLEMENTS (OLD 4)		373	417	85	333	378	317
3301915	02S/05W-23Q03S	RIVERSIDE, CITY OF	W	FREEWAY	1989	0	0	0	0	0	0
3301927	02S/05W-03R03S	AGUA MANSA PROPERTIES, INC	W	2	1974	0	0	0	0	0	0
3301940	03S/05W-09E01S	RIVERSIDE, CITY OF	W	LINCOLN HEIGHTS	1981	0	0	0	0	0	0
3301959	02S/05W-12B04S	RIVERSIDE, CITY OF	W	GARNER B		2,268	1,992	858	1,714	1,348	1,636
3302007	02S/05W-16H06S	RUBIDOUX C.S.D.	W	#2, TROYER		475	817	1,052	1,305	1,331	996
3302008	02S/05W-10K06S	RUBIDOUX C.S.D.	W	NO 1, W RIV MUTUAL	2001	0	0	0	0	0	0
3302052	02S/04W-31R01S	CANYON CREST COUNTRY CLUB	W	NO 1		27	26	25	25	25	26
3302204	02S/05W-21M03S	RIVERSIDE COUNTY PARKS DEPARTMENT	W	AG WELL #2-PIC LAK 8		0	62	12	62	62	40
3302205	02S/05W-21M01S	RIVERSIDE COUNTY PARKS DEPARTMENT	W	PIC LAK 12	1990	0	0	0	0	0	0
3302206	02S/05W-21M04S	RIVERSIDE COUNTY PARKS DEPARTMENT	W	PIC LAK 14		180	180	180	180	180	180
3302233	02S/05W-10C04S	UNIVERSAL FOREST PRODUCTS	W	1		0	0	0	0	0	0
3302234	02S/05W-10C03S	UNIVERSAL FOREST PRODUCTS	W	2		0	0	0	0	0	0
3302235	02S/05W-10C01S	UNIVERSAL FOREST PRODUCTS	W	3		0	0	0	0	0	0
3302472	02S/05W-12C03S	RIVERSIDE, CITY OF	W	GARNER C		2,911	3,533	2,254	2,209	1,572	2,496
3302531	02S/05W-12A03S	RIVERSIDE, CITY OF	W	RUSSELL B		0	0	0	0	0	0
3302538	02S/05W-20A01S	RUBIDOUX C.S.D.	W	#14, 46TH ST		6	0	246	0	0	50
3302539	02S/05W-21C01S	RUBIDOUX C.S.D.	W	#12, AIRPORT	2008	0	0	0	0	0	0
3302540	02S/05W-15M01S	RUBIDOUX C.S.D.	W	#5 DALY #1(NEW 36TH)		0	0	0	0	0	0
3302541	02S/05W-11C02S	RUBIDOUX C.S.D.	W	#4, OLD SKOTTY		747	554	567	395	327	518
3302542	02S/05W-15L01S	RUBIDOUX C.S.D.	W	#1-CRESTMORE	2002	0	0	0	0	0	0
3302605	02S/05W-03F02S	RIVERSIDE CEMENT COMPANY	W	88-1		1	0	0	0	0	0
3302618	02S/05W-12B06S	RIVERSIDE, CITY OF	W	GARNER D		2,409	2,896	1,750	1,741	792	1,918
3302772	02S/05W-11C02S	RUBIDOUX C.S.D.	W	#6, NEW SKOTTY		70	80	23	183	156	102
3302810	02S/05W-15L	RUBIDOUX C.S.D.	W	GOULD (NEW DALY #8)		1,259	1,345	1,547	2,030	2,021	1,640

**WESTERN - SAN BERNARDINO WATERMASTER
VERIFIED PRODUCTION DATA
CROSS INDEX BY RECORDATION NUMBER
RIVERSIDE SOUTH BASIN**

RECRDTN NUMBER	STATE WELL NUMBER	OWNER	WELL TYPE	LOCAL DESIGNATION	YEAR CLOSED	-----CALENDAR YEAR EXTRACTIONS-----					
						2008	2009	2010	2011	2012	AVG
3302890	02S/05W-12B07S	RIVERSIDE, CITY OF	W	RUSSELL C		593	0	0	0	0	119
3302911	02S/05W-08G05S	JURUPA COMMUNITY SERVICES DISTRICT	W	#21		603	581	401	508	485	516
3302979	02S/05W-08K05S	EMPIRE WATER	W	#2 - SCHOOL		501	427	412	386	442	434
3302980	02S/05W-08K04S	EMPIRE WATER	W	#1 - SCHOOL		74	106	63	70	61	75
3302985	02S/05W-15L11S	RUBIDOUX C.S.D.	W	#17 (NORTH WELL)		87	158	15	1,133	0	279
3302986	02S/05W-15L12	RUBIDOUX C.S.D.	W	#18 (SOUTH WELL)		3,656	3,209	2,725	1,195	2,559	2,669
3303105	02S/05W-25F02S	VICTORIA COUNTRY CLUB	W	#2		426	435	400	422	379	412
3303109	03S/05W-08B02S	CALIF BAPTIST UNIVERSITY	W	IRRIGATION		77	100	100	63	53	79
3303110	03S/05W-04N01S	HEYMING, FRANK & LUCY	W	RED BARN		0	1	13	13	13	8
3303111	02S/05W-14D01S	RIVERSIDE COUNTY FLOOD CONTROL	W	IRRIGATION		1	2	2	2	1	2
3303119	02S/05W-14B01S	RIVERSIDE UNIFIED SCHOOL DISTRICT	W	BEATTY ELEMENTARY		18	18	19	21	10	17
3303129	02S/05W-21E02S	RIVERSIDE COUNTY PARKS DEPARTMENT	W	SPORTS PARK					84	84	34
TOTALS FOR 152 WELLS						31,219	35,541	29,090	30,528	28,049	30,885

TABLE NO. 1

VERIFIED EXTRACTIONS BY OWNERS WHICH HAVE
RECORDATION FILINGS WITH THE STATE WATER
RESOURCES CONTROL BOARD

**WESTERN - SAN BERNARDINO WATERMASTER
TABLE 1
VERIFIED EXTRACTIIONS - FILED
RIVERSIDE SOUTH BASIN**

RECRDTN NUMBER	STATE WELL NUMBER	WELL TYPE	LOCAL DESIGNATION	FC	-----BASE YEARS-----						-----CALENDAR YEAR EXTRACTIIONS-----					
					1959	1960	1961	1962	1963	AVG	2008	2009	2010	2011	2012	AVG
AGUA MANSA PROPERTIES, INC																
3301927	02S/05W-03R03S	W	2	<input checked="" type="checkbox"/>							0	0	0	0	0	0
3301081	02S/05W-14B	W	ANZA	<input checked="" type="checkbox"/>	121	151	134	0	0	81	0	0	0	0	0	0
TOTALS FOR AGUA MANSA PROPERTIES, INC					121	151	134	0	0	81	0	0	0	0	0	0
ALAMO WATER COMPANY																
3301768	02S/05W-11J	W		<input type="checkbox"/>	79	100	132	163	149	125	23	36	22	22	20	25
TOTALS FOR ALAMO WATER COMPANY					79	100	132	163	149	125	23	36	22	22	20	25
BANK OF AMERICA N.T.&S.A.																
3301605	02S/04W-19P01S	W	WOODILL	<input checked="" type="checkbox"/>	90	90	90	90	94	91	0	0	0	0	0	0
TOTALS FOR BANK OF AMERICA N.T.&S.A.					90	90	90	90	94	91	0	0	0	0	0	0
BOX SPRINGS MUTUAL WATER COMPANY																
3300272	03S/04W-10A	W	13	<input checked="" type="checkbox"/>	0	0	0	0	0	0	0	0	0	0	0	0
3300272-	03S/04W-10A	W	14	<input checked="" type="checkbox"/>	0	0	0	0	0	0	0	0	0	0	0	0
3300275	03S/04W-10A	W	17	<input type="checkbox"/>	473	453	492	442	428	458	403	331	291	281	287	319
3300274	03S/04W-10B	W	8	<input checked="" type="checkbox"/>	0	0	0	0	0	0	0	0	0	0	0	0
3300274-	03S/04W-10B	W	16	<input checked="" type="checkbox"/>	53	50	55	55	42	51	0	0	0	0	0	0
3300273	03S/04W-10G	W	7	<input checked="" type="checkbox"/>	0	0	0	0	0	0	0	0	0	0	0	0
3300273-	03S/04W-10G	W	15	<input checked="" type="checkbox"/>	0	0	0	0	0	0	0	0	0	0	0	0
TOTALS FOR BOX SPRINGS MUTUAL WATER COMPANY					526	503	547	497	470	509	403	331	291	281	287	319
BURNS, F.L. & LAURA																
3300439	02S/04W-07N	W	CIT ST 2	<input checked="" type="checkbox"/>	0	0	0	0	0	0	0	0	0	0	0	0
TOTALS FOR BURNS, F.L. & LAURA					0	0	0	0	0	0	0	0	0	0	0	0
CALIF BAPTIST UNIVERSITY																
3303109	03S/05W-08B02S	W	IRRIGATION	<input type="checkbox"/>						0	77	100	100	63	53	79
TOTALS FOR CALIF BAPTIST UNIVERSITY										0	77	100	100	63	53	79
CANYON CREST COUNTRY CLUB																
3302052	02S/04W-31R01S	W	NO 1	<input type="checkbox"/>						0	27	26	25	25	25	26

**WESTERN - SAN BERNARDINO WATERMASTER
TABLE 1
VERIFIED EXTRACTIONS - FILED
RIVERSIDE SOUTH BASIN**

RECRDTN NUMBER	STATE WELL NUMBER	WELL LOCAL TYPE	LOCAL DESIGNATION	FC	-----BASE YEARS-----						-----CALENDAR YEAR EXTRACTIONS-----						
					1959	1960	1961	1962	1963	AVG	2008	2009	2010	2011	2012	AVG	
TOTALS FOR CANYON CREST COUNTRY CLUB											0	27	26	25	25	25	26
CARPENTER COMPANY																	
3301036	03S/05W-09A01S	W	CBLNCA 1	<input checked="" type="checkbox"/>	118	247	420	300	300	277	0	0	0	0	0	0	0
TOTALS FOR CARPENTER COMPANY					118	247	420	300	300	277	0	0	0	0	0	0	0
CITIZENS NATIONAL COMPANY																	
3300375	02S/05W-23L01S	W	AIR COND	<input checked="" type="checkbox"/>	0	33	33	33	33	26	0	0	0	0	0	0	0
TOTALS FOR CITIZENS NATIONAL COMPANY					0	33	33	33	33	26	0	0	0	0	0	0	0
CRESTMORE HEIGHTS MUTUAL WATER COMPANY																	
3301659	02S/05W-03B	W	3	<input checked="" type="checkbox"/>			13	44	42	20	0	0	0	0	0	0	0
3301372	02S/05W-03B02S	W	2	<input checked="" type="checkbox"/>	67	63	52	17	16	43	0	0	0	0	0	0	0
TOTALS FOR CRESTMORE HEIGHTS MUTUAL WATER COMPAN					67	63	65	61	58	63	0	0	0	0	0	0	0
EASTERN MUNICIPAL WATER DISTRICT																	
3300981	03S/04W-03Q	W	RECHE CN	<input checked="" type="checkbox"/>	0	0	0	0	0	0	0	0	0	0	0	0	0
3300982	03S/04W-03R	W	DICKNSON	<input checked="" type="checkbox"/>	3	1	0	0	0	1	0	0	0	0	0	0	0
TOTALS FOR EASTERN MUNICIPAL WATER DISTRICT					3	1	0	0	0	1	0	0	0	0	0	0	0
EMPIRE WATER																	
3302980	02S/05W-08K04S	W	#1 - SCHOOL	<input type="checkbox"/>						0	74	106	63	70	61	75	
3302979	02S/05W-08K05S	W	#2 - SCHOOL	<input type="checkbox"/>						0	501	427	412	386	442	434	
TOTALS FOR EMPIRE WATER										0	575	533	475	456	503	508	
GROSS, DALE P.																	
3300748	02S/05W-12E	W	1	<input checked="" type="checkbox"/>	0	0	0	0	0	0	0	0	0	0	0	0	0
TOTALS FOR GROSS, DALE P.					0	0	0	0	0	0	0	0	0	0	0	0	0
GRUBBS, V. W.																	
3300076	02S/04W-07P	W		<input checked="" type="checkbox"/>	45	40	51	38	39	43	0	0	0	0	0	0	0
TOTALS FOR GRUBBS, V. W.					45	40	51	38	39	43	0	0	0	0	0	0	0

WESTERN - SAN BERNARDINO WATERMASTER
TABLE 1
VERIFIED EXTRACTIIONS - FILED
RIVERSIDE SOUTH BASIN

RECRDTN NUMBER	STATE WELL NUMBER	WELL LOCAL TYPE DESIGNATION	FC	-----BASE YEARS-----						-----CALENDAR YEAR EXTRACTIIONS-----											
				1959	1960	1961	1962	1963	AVG	2008	2009	2010	2011	2012	AVG						
HEYMING, FRANK & LUCY																					
3303110	03S/05W-04N01S	W RED BARN	<input type="checkbox"/>						0	0	1	13	13	13	8						
TOTALS FOR HEYMING, FRANK & LUCY										0	0	1	13	13	13	8					
HUNTER ENGINEERING COMPANY																					
3300609	02S/04W-18C	W 3	<input checked="" type="checkbox"/>	0	0	0	31	188	44	0	0	0	0	0	0						
3300607	02S/04W-18E01S	W SMITH 1	<input checked="" type="checkbox"/>	0	0	0	0	0	0	0	0	0	0	0	0						
3300608	02S/04W-18F	W 2	<input checked="" type="checkbox"/>	0	0	0	0	0	0	0	0	0	0	0	0						
TOTALS FOR HUNTER ENGINEERING COMPANY										0	0	0	31	188	44	0	0	0	0	0	
JOHNSON, TRUMAN																					
3300160	02S/05W-14E	W 1, PALMYRITA	<input checked="" type="checkbox"/>	270	214	248	187	250	234	0	0	0	0	0	0						
TOTALS FOR JOHNSON, TRUMAN										270	214	248	187	250	234	0	0	0	0	0	
JURUPA COMMUNITY SERVICES DISTRICT																					
3301578	02S/05W-05R	W PEARSON MUTAL	<input checked="" type="checkbox"/>	9	6	6	6	78	21	0	0	0	0	0	0						
3301501	02S/05W-08G01S	W SUNNYSLOPE #5	<input type="checkbox"/>	624	180	422	275	552	411	0	0	1	1	47	10						
3301362	02S/05W-08G04S	W 3	<input checked="" type="checkbox"/>	12	180	422	275	552	288	0	0	0	0	0	0						
3302911	02S/05W-08G05S	W #21	<input type="checkbox"/>						0	603	581	401	508	485	516						
3301502	02S/05W-08K02S	W 6	<input checked="" type="checkbox"/>	308	351	103	295	116	235	0	0	0	0	0	0						
3301625	02S/05W-08K03S	W #7	<input checked="" type="checkbox"/>	50	351	103	295	116	183	0	0	0	0	0	0						
TOTALS FOR JURUPA COMMUNITY SERVICES DISTRICT										1,003	1,068	1,056	1,146	1,414	1,137	603	581	402	509	532	525
LA CASA CONTENTA MOTEL																					
3300573	02S/04W-19P	W ADLINE	<input checked="" type="checkbox"/>	0	0	0	0	0	0	0	0	0	0	0	0						
TOTALS FOR LA CASA CONTENTA MOTEL										0	0	0	0	0	0	0	0	0	0	0	
LORING RANCH 31503 LP																					
3300601	02S/05W-22D01S	W "G" (JONES RANCH)	<input type="checkbox"/>	5	5	5	5	5	5	0	0	0	0	0	0						
TOTALS FOR LORING RANCH 31503 LP										5	5	5	5	5	5	0	0	0	0	0	
MADISON, ERIN																					
3301203	02S/05W-02F	W 1 VALENCIA	<input checked="" type="checkbox"/>	564	704	731	476	912	677	0	0	0	0	0	0						
3301473	02S/05W-02F	W CHINO NO 3	<input checked="" type="checkbox"/>	603	781	465	515	531	579	0	0	0	0	0	0						

WESTERN - SAN BERNARDINO WATERMASTER

TABLE 1
VERIFIED EXTRACTIONS - FILED
RIVERSIDE SOUTH BASIN

RECRDTN NUMBER	STATE WELL NUMBER	WELL TYPE	LOCAL DESIGNATION	FC	-----BASE YEARS-----						-----CALENDAR YEAR EXTRACTIONS-----					
					1959	1960	1961	1962	1963	AVG	2008	2009	2010	2011	2012	AVG
3301626-	02S/05W-02L	W	64-1	<input checked="" type="checkbox"/>							0	0	0	0	0	0
TOTALS FOR MADISON, ERIN					1,167	1,485	1,196	991	1,443	1,256	0	0	0	0	0	0
MARTIN LINEN (TRI-CITY LINEN SUPPLY CO)																
3301384	02S/05W-22R01S	W	RIV LDRY/BLUE SEAL	<input type="checkbox"/>	30	34	38	35	31	34	88	77	64	71	55	71
TOTALS FOR MARTIN LINEN (TRI-CITY LINEN SUPPLY CO)					30	34	38	35	31	34	88	77	64	71	55	71
MARTIN, KENNETH ALLAN																
3300554	02S/05W-32B01S	W	RR 1/NICHOLS PARK	<input checked="" type="checkbox"/>	0	0	0	0	0	0	0	0	0	0	0	0
TOTALS FOR MARTIN, KENNETH ALLAN					0	0	0	0	0	0	0	0	0	0	0	0
MASTERCRAFT HOMES																
3300600	02S/05W-21A01S	W	F	<input checked="" type="checkbox"/>	564	564	564	564	564	564	0	0	0	0	0	0
3300599	02S/05W-21B01S	W	"E" (JONES RANCH)	<input checked="" type="checkbox"/>	422	422	422	422	422	422	0	0	0	0	0	0
3300597	02S/05W-22C02S	W	C	<input checked="" type="checkbox"/>	1	1	1	1	1	1	0	0	0	0	0	0
TOTALS FOR MASTERCRAFT HOMES					987	987	987	987	987	987	0	0	0	0	0	0
MICHAEL, C.																
3300595	02S/05W-22C01S	W	OLD A	<input checked="" type="checkbox"/>	0	0	0	0	0	0	0	0	0	0	0	0
3300595-	02S/05W-22D	W	A (LEVEE)	<input checked="" type="checkbox"/>	354	354	354	354	354	354	0	0	0	0	0	0
TOTALS FOR MICHAEL, C.					354	354	354	354	354	354	0	0	0	0	0	0
MIPO CORP, DBA MISSION																
3300000	02S/05W-23G02S	W	6TH ST	<input checked="" type="checkbox"/>	73	73	73	73	73	73	0	0	0	0	0	0
TOTALS FOR MIPO CORP, DBA MISSION					73	73	73	73	73	73	0	0	0	0	0	0
PROPERTY ACQUISITION COMPANY																
3301422	02S/05W-05R02S	W	PATA 66	<input checked="" type="checkbox"/>	140	136	143	139	141	140	0	0	0	0	0	0
TOTALS FOR PROPERTY ACQUISITION COMPANY					140	136	143	139	141	140	0	0	0	0	0	0
RIVERSIDE CEMENT COMPANY																
3300369	02S/05W-02E	W	CHINO NO 2	<input checked="" type="checkbox"/>	398	0	0	0	0	80	0	0	0	0	0	0
3301626	02S/05W-02L	W	53-2	<input checked="" type="checkbox"/>	350	350	0	132	110	188	0	0	0	0	0	0
3301610	02S/05W-03A03S	W	60-1 BLENDING PILE	<input type="checkbox"/>		488	2,420	2,020	1,563	1,298	1	1	1	57	1	12

WESTERN - SAN BERNARDINO WATERMASTER
TABLE 1
VERIFIED EXTRACTIONS - FILED
RIVERSIDE SOUTH BASIN

RECRDTN NUMBER	STATE WELL NUMBER	WELL TYPE	LOCAL DESIGNATION	FC	-----BASE YEARS-----						-----CALENDAR YEAR EXTRACTIONS-----					
					1959	1960	1961	1962	1963	AVG	2008	2009	2010	2011	2012	AVG
3302605	02S/05W-03F02S	W	88-1	<input type="checkbox"/>						0	1	0	0	0	0	0
3300372	02S/05W-03G02S	W	49	<input checked="" type="checkbox"/>	37	0	0	0	0	7	0	0	0	0	0	0
3300370	02S/05W-03J	W	CRESTMOR	<input checked="" type="checkbox"/>	282	242	282	282	532	324	0	0	0	0	0	0
TOTALS FOR RIVERSIDE CEMENT COMPANY					1,067	1,080	2,702	2,434	2,205	1,898	2	1	1	57	1	12
RIVERSIDE COUNTY FLOOD CONTROL																
3303111	02S/05W-14D01S	W	IRRIGATION	<input type="checkbox"/>						0	1	2	2	2	1	2
TOTALS FOR RIVERSIDE COUNTY FLOOD CONTROL										0	1	2	2	2	1	2
RIVERSIDE COUNTY PARKS DEPARTMENT																
3303129	02S/05W-21E02S	W	SPORTS PARK	<input type="checkbox"/>						0				84	84	34
3300598	02S/05W-21K	W	EDMUNDS "D"	<input type="checkbox"/>	1,220	1,220	1,220	1,220	1,220	1,220	140	140	140	175	186	156
3300596	02S/05W-21K01S	W	HQ	<input type="checkbox"/>	1	1	1	1	1	1	20	20	20	20	20	20
3302205	02S/05W-21M01S	W	PIC LAK 12	<input checked="" type="checkbox"/>	515	515	515	515	515	515	0	0	0	0	0	0
3302204	02S/05W-21M03S	W	AG WELL #2-PIC LAK	<input type="checkbox"/>						0	0	62	12	62	62	40
3302206	02S/05W-21M04S	W	PIC LAK 14	<input type="checkbox"/>	504	504	504	504	504	504	180	180	180	180	180	180
TOTALS FOR RIVERSIDE COUNTY PARKS DEPARTMENT					2,240	2,240	2,240	2,240	2,240	2,240	340	402	352	521	532	429
RIVERSIDE HIGHLAND WATER CO																
3301655	02S/04W-08M01S	W	RN #21	<input type="checkbox"/>	0	0	0	1,393	1,381	555	0	0	0	0	0	0
3301656	02S/04W-08M02S	W	RN #22	<input type="checkbox"/>			0	0	0	0	0	0	0	0	0	0
TOTALS FOR RIVERSIDE HIGHLAND WATER CO					0	0	0	1,393	1,381	555	0	0	0	0	0	0
RIVERSIDE INDUSTRIAL PARK																
3300330	02S/05W-11C01S	W	8	<input checked="" type="checkbox"/>	315	315	224	209	174	247	0	0	0	0	0	0
TOTALS FOR RIVERSIDE INDUSTRIAL PARK					315	315	224	209	174	247	0	0	0	0	0	0
RIVERSIDE THOROUGHBRED FARM																
3301834	02S/05W-15B10S	W	1	<input checked="" type="checkbox"/>					30	6	0	0	0	0	0	0
3301835	02S/05W-15B11S	W	#2	<input checked="" type="checkbox"/>					60	12	0	0	0	0	0	0
TOTALS FOR RIVERSIDE THOROUGHBRED FARM									90	18	0	0	0	0	0	0

WESTERN - SAN BERNARDINO WATERMASTER
TABLE 1
VERIFIED EXTRACTIIONS - FILED
RIVERSIDE SOUTH BASIN

RECRDTN NUMBER	STATE WELL NUMBER	WELL TYPE	LOCAL DESIGNATION	FC	-----BASE YEARS-----						-----CALENDAR YEAR EXTRACTIIONS-----						
					1959	1960	1961	1962	1963	AVG	2008	2009	2010	2011	2012	AVG	
RIVERSIDE UNIFIED SCHOOL DISTRICT																	
3303119	02S/05W-14B01S	W	BEATTY ELEMENTAR	<input type="checkbox"/>							0	18	18	19	21	10	17
TOTALS FOR RIVERSIDE UNIFIED SCHOOL DISTRICT											0	18	18	19	21	10	17
RIVERSIDE, CITY OF																	
3301287	02S/04W-07L01S	W	ELECTRIC ST	<input type="checkbox"/>	2,731	1,776	507	167	258	1,088	2,281	3,203	2,728	3,067	1,324	2,521	
3301286	02S/04W-07N01S	W	PALMYRITA 1	<input checked="" type="checkbox"/>	553	0	0	0	0	111	0	0	0	0	0	0	
3301286-	02S/04W-07N03S	W	PALMYRITA #2	<input type="checkbox"/>		1,069	811	620	599	620	1,826	2,755	2,043	1,948	2,791	2,273	
3301359	02S/04W-08D03S	W	HIGHGROVE 2	<input checked="" type="checkbox"/>	147	357	375	254	0	227	0	0	0	0	0	0	
3301359-	02S/04W-08D04S	W	HIGHGROVE 3	<input type="checkbox"/>					0	0	0	0	0	0	0	0	
3301358	02S/04W-08E01S	W	HIGHGROVE 1	<input type="checkbox"/>	220	198	210	250	439	263	0	0	0	0	0	0	
3300686	02S/04W-19J01S	W	LEMONA 1	<input checked="" type="checkbox"/>	384	319	378	203	274	312	0	0	0	0	0	0	
3301084	02S/05W-12A01S	W	RUSSELL	<input checked="" type="checkbox"/>	483	740	445	778	510	591	0	0	0	0	0	0	
3302531	02S/05W-12A03S	W	RUSSELL B	<input type="checkbox"/>						0	0	0	0	0	0	0	
3301075	02S/05W-12B01S	W	GARNER #1 (T&G)	<input type="checkbox"/>	264	383	250	534	285	343	5	4	3	3	4	4	
3301959	02S/05W-12B04S	W	GARNER B	<input type="checkbox"/>						0	2,268	1,992	858	1,714	1,348	1,636	
3302618	02S/05W-12B06S	W	GARNER D	<input type="checkbox"/>						0	2,409	2,896	1,750	1,741	792	1,918	
3302890	02S/05W-12B07S	W	RUSSELL C	<input type="checkbox"/>						0	593	0	0	0	0	119	
3302472	02S/05W-12C03S	W	GARNER C	<input type="checkbox"/>						0	2,911	3,533	2,254	2,209	1,572	2,496	
3301073	02S/05W-12K02S	W	TWIN SPRINGS 1&2	<input type="checkbox"/>	672	1,034	2,232	1,593	1,026	1,311	2,904	3,484	3,471	2,625	2,607	3,018	
3301076	02S/05W-12P01S	W	MOORE GRIFFITH #1	<input type="checkbox"/>	458	589	685	690	771	639	1,293	1,623	513	1,093	1,629	1,230	
3301077	02S/05W-12P02S	W	BRUNTON	<input type="checkbox"/>	259	299	152	482	409	320	0	0	0	0	0	0	
3301285	02S/05W-13Q01S	W	CUNHAM 1	<input checked="" type="checkbox"/>	0	0	0	0	0	0	0	0	0	0	0	0	
3301285-	02S/05W-13Q02S	W	CUNHAM 2	<input type="checkbox"/>	0	0	2,075	1,325	1,547	989	0	0	0	0	0	0	
3301851	02S/05W-14E01S	W	FAIRMOUNT PARK 2	<input type="checkbox"/>						0	37	18	11	48	49	33	
3301082	02S/05W-14G02S	W	FAIRMOUNT PARK #1	<input type="checkbox"/>	1,166	1,187	1,096	1,045	675	1,034	132	66	52	153	223	125	
3301635	02S/05W-14G03S	W	MORI	<input type="checkbox"/>		365	1,829	1,684	1,536	1,083	0	0	0	0	0	0	
3301086	02S/05W-14K	D	SPRING BROOK	<input checked="" type="checkbox"/>	0	0	0	0	0	0	0	0	0	0	0	0	
3301074	02S/05W-23J01S	W	MULBERRY	<input type="checkbox"/>	12	46	24	108	40	46	0	0	1,341	1,320	776	687	
3301289	02S/05W-23Q01S	W	11TH ST	<input type="checkbox"/>	543	760	895	573	311	616	0	0	0	0	0	0	
3301915	02S/05W-23Q03S	W	FREEWAY	<input checked="" type="checkbox"/>						0	0	0	0	0	0	0	
3301288	02S/05W-23R01S	W	FILL	<input type="checkbox"/>	651	1,103	629	369	374	625	1,214	1,939	1,389	1,371	1,521	1,487	

WESTERN - SAN BERNARDINO WATERMASTER

TABLE 1
VERIFIED EXTRACTIONS - FILED
RIVERSIDE SOUTH BASIN

RECRDTN NUMBER	STATE WELL NUMBER	WELL TYPE	LOCAL DESIGNATION	FC	-----BASE YEARS-----						-----CALENDAR YEAR EXTRACTIONS-----					
					1959	1960	1961	1962	1963	AVG	2008	2009	2010	2011	2012	AVG
3301284	02S/05W-24D01S	W	1ST ST	<input type="checkbox"/>	766	2,360	1,246	1,012	581	1,193	869	2,337	1,573	1,082	1,611	1,494
3300417	02S/05W-25F01S	W	CLEARWTR	<input checked="" type="checkbox"/>	528	631	805	23	126	423	0	0	0	0	0	0
3301078	02S/05W-28A01S	W	SANITARY	<input checked="" type="checkbox"/>	4	3	3	3	3	3	0	0	0	0	0	0
3301079	02S/05W-28C01S	W	DAVIS	<input checked="" type="checkbox"/>	0	0	0	0	0	0	0	0	0	0	0	0
3301087	02S/05W-29G	D	JENSEN	<input checked="" type="checkbox"/>	2,613	2,475	1,628	1,467	1,467	1,930	0	0	0	0	0	0
3301814	03S/05W-03F01S	W	ORANGE ACRES	<input checked="" type="checkbox"/>	24	19	18	14	12	17	0	0	0	0	0	0
3301940	03S/05W-09E01S	W	LINCOLN HEIGHTS	<input checked="" type="checkbox"/>	438	464	448	358	300	402	0	0	0	0	0	0
TOTALS FOR RIVERSIDE, CITY OF					12,916	16,177	16,741	13,552	11,543	14,186	18,742	23,850	17,986	18,374	16,247	19,040
RIVERSIDE, CITY OF-GAGE CANAL																
3300367	02S/05W-26E02S	W	OLIVEWOOD 2	<input type="checkbox"/>	1,752	1,595	1,633	985	1,165	1,426	1,260	1,281	1,144	1,361	1,295	1,268
3300366	02S/05W-26F01S	W	OLIVEWOOD 1	<input type="checkbox"/>	856	931	1,044	727	688	849	1,025	712	804	987	924	890
3300368	02S/05W-26M01S	W	OLIVEWOOD 3	<input type="checkbox"/>	449	461	559	305	318	418	907	546	705	743	385	657
TOTALS FOR RIVERSIDE, CITY OF-GAGE CANAL					3,057	2,987	3,236	2,017	2,171	2,694	3,192	2,539	2,653	3,091	2,604	2,816
RIVINO WATER COMPANY																
3301346	02S/05W-02L01S	W	1	<input checked="" type="checkbox"/>	297	211	187	477	372	309	0	0	0	0	0	0
TOTALS FOR RIVINO WATER COMPANY					297	211	187	477	372	309	0	0	0	0	0	0
ROCKY R RANCH																
3300768	03S/05W-14E	W	GURNEY 1	<input checked="" type="checkbox"/>	45	24	6	6	5	17	0	0	0	0	0	0
TOTALS FOR ROCKY R RANCH					45	24	6	6	5	17	0	0	0	0	0	0
ROOS, CHARLES E.																
3301257	02S/04W-31E01S	W	1	<input checked="" type="checkbox"/>	0	200	0	0	0	40	0	0	0	0	0	0
TOTALS FOR ROOS, CHARLES E.					0	200	0	0	0	40	0	0	0	0	0	0
ROSS, SAM																
3301194	02S/05W-12R01S	W	1 WEST	<input checked="" type="checkbox"/>	0	0	0	0	0	0	0	0	0	0	0	0
TOTALS FOR ROSS, SAM					0	0	0	0	0	0	0	0	0	0	0	0
RUBIDOUX C.S.D.																
3302008	02S/05W-10K06S	W	NO 1, W RIV MUTUAL	<input checked="" type="checkbox"/>	178	178	178	178	178	178	0	0	0	0	0	0

**WESTERN - SAN BERNARDINO WATERMASTER
TABLE 1
VERIFIED EXTRACTIIONS - FILED
RIVERSIDE SOUTH BASIN**

RECRDTN NUMBER	STATE WELL NUMBER	WELL TYPE	LOCAL DESIGNATION	FC	-----BASE YEARS-----						-----CALENDAR YEAR EXTRACTIIONS-----						
					1959	1960	1961	1962	1963	AVG	2008	2009	2010	2011	2012	AVG	
3301887	02S/05W-10P01S	W	#3 28TH ST	<input type="checkbox"/>							0	0	0	0	0	0	
3302541	02S/05W-11C02S	W	#4, OLD SKOTTY	<input type="checkbox"/>							0	747	554	567	395	327	518
3302772	02S/05W-11C02S	W	#6, NEW SKOTTY	<input type="checkbox"/>							0	70	80	23	183	156	102
3302810	02S/05W-15L	W	GOULD (NEW DALY #	<input type="checkbox"/>							0	1,259	1,345	1,547	2,030	2,021	1,640
3302542	02S/05W-15L01S	W	#1-CRESTMORE	<input checked="" type="checkbox"/>							0	0	0	0	0	0	0
3301154	02S/05W-15L09S	W	#8, 34TH & DALY	<input checked="" type="checkbox"/>	50	51	62	32	28	45	0	0	0	0	0	0	0
3302985	02S/05W-15L11S	W	#17 (NORTH WELL)	<input type="checkbox"/>							0	87	158	15	1,133	0	279
3302986	02S/05W-15L12	W	#18 (SOUTH WELL)	<input type="checkbox"/>							0	3,656	3,209	2,725	1,195	2,559	2,669
3301424	02S/05W-15M01S	W	#9, WALLACE STREE	<input checked="" type="checkbox"/>	136	195	190	140	117	156	0	0	0	0	0	0	0
3302540	02S/05W-15M01S	W	#5 DALY #1(NEW 36T	<input type="checkbox"/>							0	0	0	0	0	0	0
3301153	02S/05W-15M02S	W	#7, DALY #2	<input type="checkbox"/>	101	126	123	75	117	108	1	0	0	0	0	1	0
3301363	02S/05W-16E06S	W	OLD #4	<input checked="" type="checkbox"/>	59	90	190	130	108	115	0	0	0	0	0	0	0
3301423	02S/05W-16G04S	W	NO 1	<input checked="" type="checkbox"/>	167	136	129	126	141	140	0	0	0	0	0	0	0
3302007	02S/05W-16H06S	W	#2, TROYER	<input type="checkbox"/>							0	475	817	1,052	1,305	1,331	996
3301296	02S/05W-16J	W	#19 1-FT FREMONT N	<input type="checkbox"/>	70	27	27	18	45	37	27	5	3	0	0	0	7
3301297	02S/05W-16J	W	#20 2-FT FREMONT S	<input type="checkbox"/>	136	182	188	184	144	167	1	24	22	26	14	17	17
3300022	02S/05W-16R	W	OLD #1 (RIO RANCHO	<input checked="" type="checkbox"/>	0	0	0	0	0	0	0	0	0	0	0	0	0
3300022-	02S/05W-16R01S	W	1 (RIO RANCHO)	<input checked="" type="checkbox"/>	84	86	98	76	103	89	0	0	0	0	0	0	0
3301892	02S/05W-17R03S	W	#11 CLEMENTS (OLD	<input type="checkbox"/>							0	373	417	85	333	378	317
3301524	02S/05W-19J	W	J H #9	<input checked="" type="checkbox"/>	22	3	0	0	0	5	0	0	0	0	0	0	0
3302538	02S/05W-20A01S	W	#14, 46TH ST	<input type="checkbox"/>							0	6	0	246	0	0	50
3301694	02S/05W-20H04S	W	#13 HUNTER 6	<input type="checkbox"/>			76	100	94	54	0	0	0	0	0	0	0
3301524-	02S/05W-20J02S	W	#16 HUNTER	<input checked="" type="checkbox"/>		35	125	117	141	84	0	0	0	0	0	0	0
3302539	02S/05W-21C01S	W	#12, AIRPORT	<input checked="" type="checkbox"/>							0	0	0	0	0	0	0
TOTALS FOR RUBIDOUX C.S.D.					1,003	1,109	1,386	1,176	1,216	1,178	6,702	6,609	6,285	6,600	6,787	6,597	
SCHWAB, A. M.																	
3300230	02S/04W-08N02S	W	PLMYRTA	<input checked="" type="checkbox"/>	110	88	42	11	12	53	0	0	0	0	0	0	0
TOTALS FOR SCHWAB, A. M.					110	88	42	11	12	53	0	0	0	0	0	0	0
SCOPE CORPORATION																	
3300003	02S/04W-19J02S	W	COOK 2	<input checked="" type="checkbox"/>	99	67	85	101	5	71	0	0	0	0	0	0	0

**WESTERN - SAN BERNARDINO WATERMASTER
TABLE 1
VERIFIED EXTRACTIONS - FILED
RIVERSIDE SOUTH BASIN**

RECRDTN NUMBER	STATE WELL NUMBER	WELL TYPE	LOCAL DESIGNATION	FC	-----BASE YEARS-----						-----CALENDAR YEAR EXTRACTIONS-----					
					1959	1960	1961	1962	1963	AVG	2008	2009	2010	2011	2012	AVG
3300004	02S/04W-19R01S	W	HALL 1	<input checked="" type="checkbox"/>	17	23	50	98	95	57	0	0	0	0	0	0
TOTALS FOR SCOPE CORPORATION					116	90	135	199	100	128	0	0	0	0	0	0
STOKER, GEORGE																
3300798	02S/05W-12A	W		<input checked="" type="checkbox"/>	158	165	159	165	134	156	0	0	0	0	0	0
TOTALS FOR STOKER, GEORGE					158	165	159	165	134	156	0	0	0	0	0	0
TAYLOR, WALTER & BARBARA																
3300371	02S/05W-05K	W	FALCO	<input checked="" type="checkbox"/>	0	0	0	30	15	9	0	0	0	0	0	0
TOTALS FOR TAYLOR, WALTER & BARBARA					0	0	0	30	15	9	0	0	0	0	0	0
UNIVERSAL FOREST PRODUCTS																
3302235	02S/05W-10C01S	W	3	<input type="checkbox"/>							0	0	0	0	0	0
3302234	02S/05W-10C03S	W	2	<input type="checkbox"/>							0	0	0	0	0	0
3302233	02S/05W-10C04S	W	1	<input type="checkbox"/>							0	0	0	0	0	0
TOTALS FOR UNIVERSAL FOREST PRODUCTS											0	0	0	0	0	0
UNIVERSITY OF CALIFORNIA, REGENTS OF																
3300040	02S/04W-08D02S	W	#8, HIGHGROVE	<input type="checkbox"/>	131	283	370	94	227	221	0	0	0	0	0	0
TOTALS FOR UNIVERSITY OF CALIFORNIA, REGENTS OF					131	283	370	94	227	221	0	0	0	0	0	0
VICTORIA COUNTRY CLUB																
3300417-	02S/05W-25F01S	W	CLEARWATER	<input type="checkbox"/>	0	0	0	0	0	0	0	0	0	0	0	0
3303105	02S/05W-25F02S	W	#2	<input type="checkbox"/>							0	426	435	400	422	379
TOTALS FOR VICTORIA COUNTRY CLUB					0	0	0	0	0	0	426	435	400	422	379	412
VON KANEL, ALFRED																
3300068	02S/05W-32A01S	W		<input checked="" type="checkbox"/>	83	87	94	94	78	87	0	0	0	0	0	0
TOTALS FOR VON KANEL, ALFRED					83	87	94	94	78	87	0	0	0	0	0	0
WATERMAN, ALLEN H																
3300812	02S/05W-11P	W	WTRMN 1	<input checked="" type="checkbox"/>	25	33	16	0	0	15	0	0	0	0	0	0
TOTALS FOR WATERMAN, ALLEN H					25	33	16	0	0	15	0	0	0	0	0	0

**WESTERN - SAN BERNARDINO WATERMASTER
TABLE 1
VERIFIED EXTRACTIONS - FILED
RIVERSIDE SOUTH BASIN**

RECRDTN NUMBER	STATE WELL NUMBER	WELL LOCAL TYPE DESIGNATION	FC	-----BASE YEARS-----						-----CALENDAR YEAR EXTRACTIONS-----							
				1959	1960	1961	1962	1963	AVG	2008	2009	2010	2011	2012	AVG		
WHITE SULPHUR SPRINGS POOL																	
3300754	02S/05W-13E	W WHSLPHR 1	<input checked="" type="checkbox"/>	49	53	54	44	40	48	0	0	0	0	0	0	0	
TOTALS FOR WHITE SULPHUR SPRINGS POOL				49	53	54	44	40	48	0	0	0	0	0	0	0	0
WIGHT, CHARLES H																	
3300277	02S/05W-11K	W	<input checked="" type="checkbox"/>	76	0	0	0	0	15	0	0	0	0	0	0	0	
TOTALS FOR WIGHT, CHARLES H				76	0	0	0	0	15	0	0	0	0	0	0	0	0
ZIKE, VERA																	
3300811	02S/05W-32K01S	W WAYMAN	<input checked="" type="checkbox"/>	53	37	47	20	18	35	0	0	0	0	0	0	0	
TOTALS FOR ZIKE, VERA				53	37	47	20	18	35	0	0	0	0	0	0	0	0
TOTALS FOR 150 WELLS				26,819	30,763	33,211	29,291	28,050	29,627	31,219	35,541	29,090	30,528	28,049	30,885		

TABLE NO. 2

VERIFIED EXTRACTIONS BY OWNERS WHICH
HAVE NOT FILED WITH THE STATE WATER
RESOURCES CONTROL BOARD

SANTA ANA RIVER WHITEWATER RIVER WATERSHEDS COOPERATIVE WATER RECORDATION PROGRAM

TABLE 2

VERIFIED EXTRACTIONS - NON-FILED
RIVERSIDE SOUTH BASIN

RECRDTN NUMBER	STATE WELL NUMBER	WELL TYPE	LOCAL DESIGNATION	FC	-----BASE YEARS-----						-----CALENDAR YEAR EXTRACTIONS-----						
					1959	1960	1961	1962	1963	AVG	2008	2009	2010	2011	2012	AVG	
RUBIDOUX C.S.D.																	
0000401	02S/05W-20R01S	W	SEWER PLANT	<input checked="" type="checkbox"/>	3	3	3	3	3	3	3	0	0	0	0	0	0
TOTALS FOR RUBIDOUX C.S.D.					3	3	3	3	3	3	3	0	0	0	0	0	0
JOHNSON, TRUMAN																	
0000402	02S/05W-14E	W	1	<input checked="" type="checkbox"/>	4	4	4	4	4	4	4	0	0	0	0	0	0
TOTALS FOR JOHNSON, TRUMAN					4	4	4	4	4	4	4	0	0	0	0	0	0
TOTALS FOR 2 WELLS					7	7	7	7	7	7	7	0	0	0	0	0	0

TABLE NO. 3
VERIFIED EXTRACTIONS
(FILED AND NON-FILED)
FROM RIVERSIDE BASIN AREA WITHIN RIVERSIDE COUNTY

**WESTERN - SAN BERNARDINO WATERMASTER
TABLE 3
VERIFIED EXTRACTIONS - FILED AND NONFILED DETAIL
RIVERSIDE SOUTH BASIN**

RECRDTN NUMBER	STATE NUMBER	WELL TYPE	WELL LOCAL DESIGNATION	-----BASE YEARS-----						-----CALENDAR YEAR EXTRACTIONS-----					
				1959	1960	1961	1962	1963	AVG	2008	2009	2010	2011	2012	AVG
AGUA MANSA PROPERTIES, INC															
3301927	02S/05W-03R03S	W	2							0	0	0	0	0	0
3301081	02S/05W-14B	W	ANZA	121	151	134	0	0	81	0	0	0	0	0	0
TOTALS FOR AGUA MANSA PROPERTIES, INC				121	151	134	0	0	81	0	0	0	0	0	0
ALAMO WATER COMPANY															
3301768	02S/05W-11J	W		79	100	132	163	149	125	23	36	22	22	20	25
TOTALS FOR ALAMO WATER COMPANY				79	100	132	163	149	125	23	36	22	22	20	25
BANK OF AMERICA N.T.&S.A.															
3301605	02S/04W-19P01S	W	WOODILL	90	90	90	90	94	91	0	0	0	0	0	0
TOTALS FOR BANK OF AMERICA N.T.&S.A.				90	90	90	90	94	91	0	0	0	0	0	0
BOX SPRINGS MUTUAL WATER COMPANY															
3300272	03S/04W-10A	W	13	0	0	0	0	0	0	0	0	0	0	0	0
3300272-	03S/04W-10A	W	14	0	0	0	0	0	0	0	0	0	0	0	0
3300275	03S/04W-10A	W	17	473	453	492	442	428	458	403	331	291	281	287	319
3300274	03S/04W-10B	W	8	0	0	0	0	0	0	0	0	0	0	0	0
3300274-	03S/04W-10B	W	16	53	50	55	55	42	51	0	0	0	0	0	0
3300273	03S/04W-10G	W	7	0	0	0	0	0	0	0	0	0	0	0	0
3300273-	03S/04W-10G	W	15	0	0	0	0	0	0	0	0	0	0	0	0
TOTALS FOR BOX SPRINGS MUTUAL WATER COMPANY				526	503	547	497	470	509	403	331	291	281	287	319
BURNS, F.L. & LAURA															
3300439	02S/04W-07N	W	CIT ST 2	0	0	0	0	0	0	0	0	0	0	0	0
TOTALS FOR BURNS, F.L. & LAURA				0	0	0	0	0	0	0	0	0	0	0	0
CALIF BAPTIST UNIVERSITY															
3303109	03S/05W-08B02S	W	IRRIGATION						0	77	100	100	63	53	79
TOTALS FOR CALIF BAPTIST UNIVERSITY									0	77	100	100	63	53	79
CANYON CREST COUNTRY CLUB															
3302052	02S/04W-31R01S	W	NO 1						0	27	26	25	25	25	26
TOTALS FOR CANYON CREST COUNTRY CLUB									0	27	26	25	25	25	26

**WESTERN - SAN BERNARDINO WATERMASTER
TABLE 3
VERIFIED EXTRACTIONS - FILED AND NONFILED DETAIL
RIVERSIDE SOUTH BASIN**

RECRDTN NUMBER	STATE WELL NUMBER	WELL TYPE	LOCAL DESIGNATION	-----BASE YEARS-----						-----CALENDAR YEAR EXTRACTIONS-----					
				1959	1960	1961	1962	1963	AVG	2008	2009	2010	2011	2012	AVG
CARPENTER COMPANY															
3301036	03S/05W-09A01S	W	CBLNCA 1	118	247	420	300	300	277	0	0	0	0	0	0
TOTALS FOR CARPENTER COMPANY				118	247	420	300	300	277	0	0	0	0	0	0
CITIZENS NATIONAL COMPANY															
3300375	02S/05W-23L01S	W	AIR COND	0	33	33	33	33	26	0	0	0	0	0	0
TOTALS FOR CITIZENS NATIONAL COMPANY				0	33	33	33	33	26	0	0	0	0	0	0
CRESTMORE HEIGHTS MUTUAL WATER COMPANY															
3301659	02S/05W-03B	W	3			13	44	42	20	0	0	0	0	0	0
3301372	02S/05W-03B02S	W	2	67	63	52	17	16	43	0	0	0	0	0	0
TOTALS FOR CRESTMORE HEIGHTS MUTUAL WATER COMPAN				67	63	65	61	58	63	0	0	0	0	0	0
EASTERN MUNICIPAL WATER DISTRICT															
3300981	03S/04W-03Q	W	RECHE CN	0	0	0	0	0	0	0	0	0	0	0	0
3300982	03S/04W-03R	W	DICKNSON	3	1	0	0	0	1	0	0	0	0	0	0
TOTALS FOR EASTERN MUNICIPAL WATER DISTRICT				3	1	0	0	0	1	0	0	0	0	0	0
EMPIRE WATER															
3302980	02S/05W-08K04S	W	#1 - SCHOOL						0	74	106	63	70	61	75
3302979	02S/05W-08K05S	W	#2 - SCHOOL						0	501	427	412	386	442	434
TOTALS FOR EMPIRE WATER									0	575	533	475	456	503	508
GROSS, DALE P.															
3300748	02S/05W-12E	W	1	0	0	0	0	0	0	0	0	0	0	0	0
TOTALS FOR GROSS, DALE P.				0	0	0	0	0	0	0	0	0	0	0	0
GRUBBS, V. W.															
3300076	02S/04W-07P	W		45	40	51	38	39	43	0	0	0	0	0	0
TOTALS FOR GRUBBS, V. W.				45	40	51	38	39	43	0	0	0	0	0	0
HEYMING, FRANK & LUCY															
3303110	03S/05W-04N01S	W	RED BARN						0	0	1	13	13	13	8
TOTALS FOR HEYMING, FRANK & LUCY									0	0	1	13	13	13	8

**WESTERN - SAN BERNARDINO WATERMASTER
TABLE 3
VERIFIED EXTRACTIONS - FILED AND NONFILED DETAIL
RIVERSIDE SOUTH BASIN**

RECRDTN NUMBER	STATE NUMBER	WELL TYPE	WELL LOCAL DESIGNATION	-----BASE YEARS-----						-----CALENDAR YEAR EXTRACTIONS-----					
				1959	1960	1961	1962	1963	AVG	2008	2009	2010	2011	2012	AVG
HUNTER ENGINEERING COMPANY															
3300609	02S/04W-18C	W	3	0	0	0	31	188	44	0	0	0	0	0	0
3300607	02S/04W-18E01S	W	SMITH 1	0	0	0	0	0	0	0	0	0	0	0	0
3300608	02S/04W-18F	W	2	0	0	0	0	0	0	0	0	0	0	0	0
TOTALS FOR HUNTER ENGINEERING COMPANY				0	0	0	31	188	44	0	0	0	0	0	0
JOHNSON, TRUMAN															
0000402	02S/05W-14E	W	1	4	4	4	4	4	4	0	0	0	0	0	0
3300160	02S/05W-14E	W	1, PALMYRITA	270	214	248	187	250	234	0	0	0	0	0	0
TOTALS FOR JOHNSON, TRUMAN				274	218	252	191	254	238	0	0	0	0	0	0
JURUPA COMMUNITY SERVICES DISTRICT															
3301578	02S/05W-05R	W	PEARSON MUTAL	9	6	6	6	78	21	0	0	0	0	0	0
3301501	02S/05W-08G01S	W	SUNNYSLOPE #5	624	180	422	275	552	411	0	0	1	1	47	10
3301362	02S/05W-08G04S	W	3	12	180	422	275	552	288	0	0	0	0	0	0
3302911	02S/05W-08G05S	W	#21						0	603	581	401	508	485	516
3301502	02S/05W-08K02S	W	6	308	351	103	295	116	235	0	0	0	0	0	0
3301625	02S/05W-08K03S	W	#7	50	351	103	295	116	183	0	0	0	0	0	0
TOTALS FOR JURUPA COMMUNITY SERVICES DISTRICT				1,003	1,068	1,056	1,146	1,414	1,137	603	581	402	509	532	525
LA CASA CONTENTA MOTEL															
3300573	02S/04W-19P	W	ADLINE	0	0	0	0	0	0	0	0	0	0	0	0
TOTALS FOR LA CASA CONTENTA MOTEL				0	0	0	0	0	0	0	0	0	0	0	0
LORING RANCH 31503 LP															
3300601	02S/05W-22D01S	W	"G" (JONES RANCH)	5	5	5	5	5	5	0	0	0	0	0	0
TOTALS FOR LORING RANCH 31503 LP				5	5	5	5	5	5	0	0	0	0	0	0
MADISON, ERIN															
3301203	02S/05W-02F	W	1 VALENCIA	564	704	731	476	912	677	0	0	0	0	0	0
3301473	02S/05W-02F	W	CHINO NO 3	603	781	465	515	531	579	0	0	0	0	0	0
3301626-	02S/05W-02L	W	64-1						0	0	0	0	0	0	0
TOTALS FOR MADISON, ERIN				1,167	1,485	1,196	991	1,443	1,256	0	0	0	0	0	0

**WESTERN - SAN BERNARDINO WATERMASTER
TABLE 3
VERIFIED EXTRACTIONS - FILED AND NONFILED DETAIL
RIVERSIDE SOUTH BASIN**

RECRDTN NUMBER	STATE WELL NUMBER	WELL TYPE	LOCAL DESIGNATION	-----BASE YEARS-----						-----CALENDAR YEAR EXTRACTIONS-----					
				1959	1960	1961	1962	1963	AVG	2008	2009	2010	2011	2012	AVG
MARTIN LINEN (TRI-CITY LINEN SUPPLY CO)															
3301384	02S/05W-22R01S	W	RIV LDRY/BLUE SEAL	30	34	38	35	31	34	88	77	64	71	55	71
TOTALS FOR MARTIN LINEN (TRI-CITY LINEN SUPPLY CO)				30	34	38	35	31	34	88	77	64	71	55	71
MARTIN, KENNETH ALLAN															
3300554	02S/05W-32B01S	W	RR 1/NICHOLS PARK	0	0	0	0	0	0	0	0	0	0	0	0
TOTALS FOR MARTIN, KENNETH ALLAN				0	0	0	0	0	0	0	0	0	0	0	0
MASTERCRAFT HOMES															
3300600	02S/05W-21A01S	W	F	564	564	564	564	564	564	0	0	0	0	0	0
3300599	02S/05W-21B01S	W	"E" (JONES RANCH)	422	422	422	422	422	422	0	0	0	0	0	0
3300597	02S/05W-22C02S	W	C	1	1	1	1	1	1	0	0	0	0	0	0
TOTALS FOR MASTERCRAFT HOMES				987	987	987	987	987	987	0	0	0	0	0	0
MICHAEL, C.															
3300595	02S/05W-22C01S	W	OLD A	0	0	0	0	0	0	0	0	0	0	0	0
3300595-	02S/05W-22D	W	A (LEVEE)	354	354	354	354	354	354	0	0	0	0	0	0
TOTALS FOR MICHAEL, C.				354	354	354	354	354	354	0	0	0	0	0	0
MIPO CORP, DBA MISSION															
3300000	02S/05W-23G02S	W	6TH ST	73	73	73	73	73	73	0	0	0	0	0	0
TOTALS FOR MIPO CORP, DBA MISSION				73	73	73	73	73	73	0	0	0	0	0	0
PROPERTY ACQUISITION COMPANY															
3301422	02S/05W-05R02S	W	PATA 66	140	136	143	139	141	140	0	0	0	0	0	0
TOTALS FOR PROPERTY ACQUISITION COMPANY				140	136	143	139	141	140	0	0	0	0	0	0
RIVERSIDE CEMENT COMPANY															
3300369	02S/05W-02E	W	CHINO NO 2	398	0	0	0	0	80	0	0	0	0	0	0
3301626	02S/05W-02L	W	53-2	350	350	0	132	110	188	0	0	0	0	0	0
3301610	02S/05W-03A03S	W	60-1 BLENDING PILE		488	2,420	2,020	1,563	1,298	1	1	1	57	1	12
3302605	02S/05W-03F02S	W	88-1						0	1	0	0	0	0	0
3300372	02S/05W-03G02S	W	49	37	0	0	0	0	7	0	0	0	0	0	0
3300370	02S/05W-03J	W	CRESTMOR	282	242	282	282	532	324	0	0	0	0	0	0

**WESTERN - SAN BERNARDINO WATERMASTER
TABLE 3
VERIFIED EXTRACTIONS - FILED AND NONFILED DETAIL
RIVERSIDE SOUTH BASIN**

RECRDTN NUMBER	STATE WELL NUMBER	WELL TYPE	LOCAL DESIGNATION	-----BASE YEARS-----						-----CALENDAR YEAR EXTRACTIONS-----					
				1959	1960	1961	1962	1963	AVG	2008	2009	2010	2011	2012	AVG
TOTALS FOR RIVERSIDE CEMENT COMPANY				1,067	1,080	2,702	2,434	2,205	1,898	2	1	1	57	1	12
RIVERSIDE COUNTY FLOOD CONTROL															
3303111	02S/05W-14D01S	W	IRRIGATION						0	1	2	2	2	1	2
TOTALS FOR RIVERSIDE COUNTY FLOOD CONTROL									0	1	2	2	2	1	2
RIVERSIDE COUNTY PARKS DEPARTMENT															
3303129	02S/05W-21E02S	W	SPORTS PARK						0				84	84	34
3300598	02S/05W-21K	W	EDMUNDS "D"	1,220	1,220	1,220	1,220	1,220	1,220	140	140	140	175	186	156
3300596	02S/05W-21K01S	W	HQ	1	1	1	1	1	1	20	20	20	20	20	20
3302205	02S/05W-21M01S	W	PIC LAK 12	515	515	515	515	515	515	0	0	0	0	0	0
3302204	02S/05W-21M03S	W	AG WELL #2-PIC LAK 8						0	0	62	12	62	62	40
3302206	02S/05W-21M04S	W	PIC LAK 14	504	504	504	504	504	504	180	180	180	180	180	180
TOTALS FOR RIVERSIDE COUNTY PARKS DEPARTMENT				2,240	2,240	2,240	2,240	2,240	2,240	340	402	352	521	532	429
RIVERSIDE HIGHLAND WATER CO															
3301655	02S/04W-08M01S	W	RN #21	0	0	0	1,393	1,381	555	0	0	0	0	0	0
3301656	02S/04W-08M02S	W	RN #22				0	0	0	0	0	0	0	0	0
TOTALS FOR RIVERSIDE HIGHLAND WATER CO				0	0	0	1,393	1,381	555	0	0	0	0	0	0
RIVERSIDE INDUSTRIAL PARK															
3300330	02S/05W-11C01S	W	8	315	315	224	209	174	247	0	0	0	0	0	0
TOTALS FOR RIVERSIDE INDUSTRIAL PARK				315	315	224	209	174	247	0	0	0	0	0	0
RIVERSIDE THOROUGHBRED FARM															
3301834	02S/05W-15B10S	W	1					30	6	0	0	0	0	0	0
3301835	02S/05W-15B11S	W	#2					60	12	0	0	0	0	0	0
TOTALS FOR RIVERSIDE THOROUGHBRED FARM								90	0	0	0	0	0	0	0
RIVERSIDE UNIFIED SCHOOL DISTRICT															
3303119	02S/05W-14B01S	W	BEATTY ELEMENTARY						0	18	18	19	21	10	17
TOTALS FOR RIVERSIDE UNIFIED SCHOOL DISTRICT									0	18	18	19	21	10	17
RIVERSIDE, CITY OF															
3301287	02S/04W-07L01S	W	ELECTRIC ST	2,731	1,776	507	167	258	1,088	2,281	3,203	2,728	3,067	1,324	2,521

**WESTERN - SAN BERNARDINO WATERMASTER
TABLE 3
VERIFIED EXTRACTIONS - FILED AND NONFILED DETAIL
RIVERSIDE SOUTH BASIN**

RECRDTN NUMBER	STATE WELL NUMBER	WELL TYPE	LOCAL DESIGNATION	-----BASE YEARS-----						-----CALENDAR YEAR EXTRACTIONS-----					
				1959	1960	1961	1962	1963	AVG	2008	2009	2010	2011	2012	AVG
3301286	02S/04W-07N01S	W	PALMYRITA 1	553	0	0	0	0	111	0	0	0	0	0	0
3301286-	02S/04W-07N03S	W	PALMYRITA #2		1,069	811	620	599	620	1,826	2,755	2,043	1,948	2,791	2,273
3301359	02S/04W-08D03S	W	HIGHGROVE 2	147	357	375	254	0	227	0	0	0	0	0	0
3301359-	02S/04W-08D04S	W	HIGHGROVE 3					0	0	0	0	0	0	0	0
3301358	02S/04W-08E01S	W	HIGHGROVE 1	220	198	210	250	439	263	0	0	0	0	0	0
3300686	02S/04W-19J01S	W	LEMONA 1	384	319	378	203	274	312	0	0	0	0	0	0
3301084	02S/05W-12A01S	W	RUSSELL	483	740	445	778	510	591	0	0	0	0	0	0
3302531	02S/05W-12A03S	W	RUSSELL B						0	0	0	0	0	0	0
3301075	02S/05W-12B01S	W	GARNER #1 (T&G)	264	383	250	534	285	343	5	4	3	3	4	4
3301959	02S/05W-12B04S	W	GARNER B						0	2,268	1,992	858	1,714	1,348	1,636
3302618	02S/05W-12B06S	W	GARNER D						0	2,409	2,896	1,750	1,741	792	1,918
3302890	02S/05W-12B07S	W	RUSSELL C						0	593	0	0	0	0	119
3302472	02S/05W-12C03S	W	GARNER C						0	2,911	3,533	2,254	2,209	1,572	2,496
3301073	02S/05W-12K02S	W	TWIN SPRINGS 1&2	672	1,034	2,232	1,593	1,026	1,311	2,904	3,484	3,471	2,625	2,607	3,018
3301076	02S/05W-12P01S	W	MOORE GRIFFITH #1	458	589	685	690	771	639	1,293	1,623	513	1,093	1,629	1,230
3301077	02S/05W-12P02S	W	BRUNTON	259	299	152	482	409	320	0	0	0	0	0	0
3301285	02S/05W-13Q01S	W	CUNHAM 1	0	0	0	0	0	0	0	0	0	0	0	0
3301285-	02S/05W-13Q02S	W	CUNHAM 2	0	0	2,075	1,325	1,547	989	0	0	0	0	0	0
3301851	02S/05W-14E01S	W	FAIRMOUNT PARK 2						0	37	18	11	48	49	33
3301082	02S/05W-14G02S	W	FAIRMOUNT PARK #1	1,166	1,187	1,096	1,045	675	1,034	132	66	52	153	223	125
3301635	02S/05W-14G03S	W	MORI		365	1,829	1,684	1,536	1,083	0	0	0	0	0	0
3301086	02S/05W-14K	D	SPRING BROOK	0	0	0	0	0	0	0	0	0	0	0	0
3301074	02S/05W-23J01S	W	MULBERRY	12	46	24	108	40	46	0	0	1,341	1,320	776	687
3301289	02S/05W-23Q01S	W	11TH ST	543	760	895	573	311	616	0	0	0	0	0	0
3301915	02S/05W-23Q03S	W	FREEWAY						0	0	0	0	0	0	0
3301288	02S/05W-23R01S	W	FILL	651	1,103	629	369	374	625	1,214	1,939	1,389	1,371	1,521	1,487
3301284	02S/05W-24D01S	W	1ST ST	766	2,360	1,246	1,012	581	1,193	869	2,337	1,573	1,082	1,611	1,494
3300417	02S/05W-25F01S	W	CLEARWTR	528	631	805	23	126	423	0	0	0	0	0	0
3301078	02S/05W-28A01S	W	SANITARY	4	3	3	3	3	3	0	0	0	0	0	0
3301079	02S/05W-28C01S	W	DAVIS	0	0	0	0	0	0	0	0	0	0	0	0
3301087	02S/05W-29G	D	JENSEN	2,613	2,475	1,628	1,467	1,467	1,930	0	0	0	0	0	0
3301814	03S/05W-03F01S	W	ORANGE ACRES	24	19	18	14	12	17	0	0	0	0	0	0
3301940	03S/05W-09E01S	W	LINCOLN HEIGHTS	438	464	448	358	300	402	0	0	0	0	0	0
TOTALS FOR RIVERSIDE, CITY OF				12,916	16,177	16,741	13,552	11,543	14,186	18,742	23,850	17,986	18,374	16,247	19,040

**WESTERN - SAN BERNARDINO WATERMASTER
TABLE 3
VERIFIED EXTRACTIONS - FILED AND NONFILED DETAIL
RIVERSIDE SOUTH BASIN**

RECRDTN NUMBER	STATE WELL NUMBER	WELL TYPE	LOCAL DESIGNATION	-----BASE YEARS-----						-----CALENDAR YEAR EXTRACTIONS-----						
				1959	1960	1961	1962	1963	AVG	2008	2009	2010	2011	2012	AVG	
RIVERSIDE, CITY OF-GAGE CANAL																
3300367	02S/05W-26E02S	W	OLIVEWOOD 2	1,752	1,595	1,633	985	1,165	1,426	1,260	1,281	1,144	1,361	1,295	1,268	
3300366	02S/05W-26F01S	W	OLIVEWOOD 1	856	931	1,044	727	688	849	1,025	712	804	987	924	890	
3300368	02S/05W-26M01S	W	OLIVEWOOD 3	449	461	559	305	318	418	907	546	705	743	385	657	
TOTALS FOR RIVERSIDE, CITY OF-GAGE CANAL				3,057	2,987	3,236	2,017	2,171	2,694	3,192	2,539	2,653	3,091	2,604	2,816	
RIVINO WATER COMPANY																
3301346	02S/05W-02L01S	W	1	297	211	187	477	372	309	0	0	0	0	0	0	
TOTALS FOR RIVINO WATER COMPANY				297	211	187	477	372	309	0	0	0	0	0	0	0
ROCKY R RANCH																
3300768	03S/05W-14E	W	GURNEY 1	45	24	6	6	5	17	0	0	0	0	0	0	
TOTALS FOR ROCKY R RANCH				45	24	6	6	5	17	0	0	0	0	0	0	0
ROOS, CHARLES E.																
3301257	02S/04W-31E01S	W	1	0	200	0	0	0	40	0	0	0	0	0	0	
TOTALS FOR ROOS, CHARLES E.				0	200	0	0	0	40	0	0	0	0	0	0	0
ROSS, SAM																
3301194	02S/05W-12R01S	W	1 WEST	0	0	0	0	0	0	0	0	0	0	0	0	
TOTALS FOR ROSS, SAM				0	0	0	0	0	0	0	0	0	0	0	0	0
RUBIDOUX C.S.D.																
3302008	02S/05W-10K06S	W	NO 1, W RIV MUTUAL	178	178	178	178	178	178	0	0	0	0	0	0	
3301887	02S/05W-10P01S	W	#3 28TH ST						0	0	0	0	0	0	0	
3302541	02S/05W-11C02S	W	#4, OLD SKOTTY						0	747	554	567	395	327	518	
3302772	02S/05W-11C02S	W	#6, NEW SKOTTY						0	70	80	23	183	156	102	
3302810	02S/05W-15L	W	GOULD (NEW DALY #8)						0	1,259	1,345	1,547	2,030	2,021	1,640	
3302542	02S/05W-15L01S	W	#1-CRESTMORE						0	0	0	0	0	0	0	
3301154	02S/05W-15L09S	W	#8, 34TH & DALY	50	51	62	32	28	45	0	0	0	0	0	0	
3302985	02S/05W-15L11S	W	#17 (NORTH WELL)						0	87	158	15	1,133	0	279	
3302986	02S/05W-15L12	W	#18 (SOUTH WELL)						0	3,656	3,209	2,725	1,195	2,559	2,669	
3301424	02S/05W-15M01S	W	#9, WALLACE STREET	136	195	190	140	117	156	0	0	0	0	0	0	
3302540	02S/05W-15M01S	W	#5 DALY #1(NEW 36TH)						0	0	0	0	0	0	0	
3301153	02S/05W-15M02S	W	#7, DALY #2	101	126	123	75	117	108	1	0	0	0	1	0	

**WESTERN - SAN BERNARDINO WATERMASTER
TABLE 3
VERIFIED EXTRACTIONS - FILED AND NONFILED DETAIL
RIVERSIDE SOUTH BASIN**

RECRDTN NUMBER	STATE WELL NUMBER	WELL TYPE	LOCAL DESIGNATION	-----BASE YEARS-----							-----CALENDAR YEAR EXTRACTIONS-----					
				1959	1960	1961	1962	1963	AVG	2008	2009	2010	2011	2012	AVG	
3301363	02S/05W-16E06S	W	OLD #4	59	90	190	130	108	115	0	0	0	0	0	0	
3301423	02S/05W-16G04S	W	NO 1	167	136	129	126	141	140	0	0	0	0	0	0	
3302007	02S/05W-16H06S	W	#2, TROYER						0	475	817	1,052	1,305	1,331	996	
3301296	02S/05W-16J	W	#19 1-FT FREMONT NE	70	27	27	18	45	37	27	5	3	0	0	7	
3301297	02S/05W-16J	W	#20 2-FT FREMONT SW	136	182	188	184	144	167	1	24	22	26	14	17	
3300022	02S/05W-16R	W	OLD #1 (RIO RANCHO)	0	0	0	0	0	0	0	0	0	0	0	0	
3300022-	02S/05W-16R01S	W	1 (RIO RANCHO)	84	86	98	76	103	89	0	0	0	0	0	0	
3301892	02S/05W-17R03S	W	#11 CLEMENTS (OLD 4)						0	373	417	85	333	378	317	
3301524	02S/05W-19J	W	J H #9	22	3	0	0	0	5	0	0	0	0	0	0	
3302538	02S/05W-20A01S	W	#14, 46TH ST						0	6	0	246	0	0	50	
3301694	02S/05W-20H04S	W	#13 HUNTER 6			76	100	94	54	0	0	0	0	0	0	
3301524-	02S/05W-20J02S	W	#16 HUNTER		35	125	117	141	84	0	0	0	0	0	0	
0000401	02S/05W-20R01S	W	SEWER PLANT	3	3	3	3	3	3	0	0	0	0	0	0	
3302539	02S/05W-21C01S	W	#12, AIRPORT						0	0	0	0	0	0	0	
TOTALS FOR RUBIDOUX C.S.D.				1,006	1,112	1,389	1,179	1,219	1,181	6,702	6,609	6,285	6,600	6,787	6,597	
SCHWAB, A. M.																
3300230	02S/04W-08N02S	W	PLMYRTA	110	88	42	11	12	53	0	0	0	0	0	0	
TOTALS FOR SCHWAB, A. M.				110	88	42	11	12	53	0	0	0	0	0	0	
SCOPE CORPORATION																
3300003	02S/04W-19J02S	W	COOK 2	99	67	85	101	5	71	0	0	0	0	0	0	
3300004	02S/04W-19R01S	W	HALL 1	17	23	50	98	95	57	0	0	0	0	0	0	
TOTALS FOR SCOPE CORPORATION				116	90	135	199	100	128	0	0	0	0	0	0	
STOKER, GEORGE																
3300798	02S/05W-12A	W		158	165	159	165	134	156	0	0	0	0	0	0	
TOTALS FOR STOKER, GEORGE				158	165	159	165	134	156	0	0	0	0	0	0	
TAYLOR, WALTER & BARBARA																
3300371	02S/05W-05K	W	FALCO	0	0	0	30	15	9	0	0	0	0	0	0	
TOTALS FOR TAYLOR, WALTER & BARBARA				0	0	0	30	15	9	0	0	0	0	0	0	
UNIVERSAL FOREST PRODUCTS																
3302235	02S/05W-10C01S	W	3						0	0	0	0	0	0	0	

**WESTERN - SAN BERNARDINO WATERMASTER
TABLE 3
VERIFIED EXTRACTIONS - FILED AND NONFILED DETAIL
RIVERSIDE SOUTH BASIN**

RECRDTN NUMBER	STATE WELL NUMBER	WELL TYPE	LOCAL DESIGNATION	-----BASE YEARS-----					-----CALENDAR YEAR EXTRACTIONS-----								
				1959	1960	1961	1962	1963	AVG	2008	2009	2010	2011	2012	AVG		
3302234	02S/05W-10C03S	W	2							0	0	0	0	0	0	0	
3302233	02S/05W-10C04S	W	1							0	0	0	0	0	0	0	
TOTALS FOR UNIVERSAL FOREST PRODUCTS										0	0	0	0	0	0	0	
UNIVERSITY OF CALIFORNIA, REGENTS OF																	
3300040	02S/04W-08D02S	W	#8, HIGHGROVE	131	283	370	94	227	221	0	0	0	0	0	0	0	
TOTALS FOR UNIVERSITY OF CALIFORNIA, REGENTS OF				131	283	370	94	227	221	0	0	0	0	0	0	0	
VICTORIA COUNTRY CLUB																	
3300417-	02S/05W-25F01S	W	CLEARWATER	0	0	0	0	0	0	0	0	0	0	0	0	0	
3303105	02S/05W-25F02S	W	#2							0	426	435	400	422	379	412	
TOTALS FOR VICTORIA COUNTRY CLUB				0	0	0	0	0	0	0	426	435	400	422	379	412	
VON KANEL, ALFRED																	
3300068	02S/05W-32A01S	W		83	87	94	94	78	87	0	0	0	0	0	0	0	
TOTALS FOR VON KANEL, ALFRED				83	87	94	94	78	87	0	0	0	0	0	0	0	0
WATERMAN, ALLEN H																	
3300812	02S/05W-11P	W	WTRMN 1	25	33	16	0	0	15	0	0	0	0	0	0	0	
TOTALS FOR WATERMAN, ALLEN H				25	33	16	0	0	15	0	0	0	0	0	0	0	0
WHITE SULPHUR SPRINGS POOL																	
3300754	02S/05W-13E	W	WHSLPHR 1	49	53	54	44	40	48	0	0	0	0	0	0	0	
TOTALS FOR WHITE SULPHUR SPRINGS POOL				49	53	54	44	40	48	0	0	0	0	0	0	0	0
WIGHT, CHARLES H																	
3300277	02S/05W-11K	W		76	0	0	0	0	15	0	0	0	0	0	0	0	
TOTALS FOR WIGHT, CHARLES H				76	0	0	0	0	15	0	0	0	0	0	0	0	0
ZIKE, VERA																	
3300811	02S/05W-32K01S	W	WAYMAN	53	37	47	20	18	35	0	0	0	0	0	0	0	
TOTALS FOR ZIKE, VERA				53	37	47	20	18	35	0	0	0	0	0	0	0	0
TOTALS FOR 152 WELLS				26,826	30,770	33,218	29,298	28,057	29,634	31,219	35,541	29,090	30,528	28,049	30,885		

TABLE NO. 3
SUMMARY OF VERIFIED EXTRACTIONS
(FILED AND NON-FILED)
FROM RIVERSIDE BASIN AREA WITHIN RIVERSIDE COUNTY

WESTERN - SAN BERNARDINO WATERMASTER
TABLE 3
VERIFIED EXTRACTION, SUMMARY - FILED AND NON-FILED
RIVERSIDE SOUTH BASIN

	-----BASE YEARS-----						-----CALENDAR YEAR EXTRACTIONS-----					
	1959	1960	1961	1962	1963	AVG	2008	2009	2010	2011	2012	AVG
AGUA MANSÁ PROPERTIES, INC	121	151	134	0	0	81	0	0	0	0	0	0
ALAMO WATER COMPANY	79	100	132	163	149	125	23	36	22	22	20	25
BANK OF AMERICA N.T.&S.A.	90	90	90	90	94	91	0	0	0	0	0	0
BOX SPRINGS MUTUAL WATER COMPANY	526	503	547	497	470	509	403	331	291	281	287	319
BURNS, F.L. & LAURA	0	0	0	0	0	0	0	0	0	0	0	0
CALIF BAPTIST UNIVERSITY						0	77	100	100	63	53	79
CANYON CREST COUNTRY CLUB						0	27	26	25	25	25	26
CARPENTER COMPANY	118	247	420	300	300	277	0	0	0	0	0	0
CITIZENS NATIONAL COMPANY	0	33	33	33	33	26	0	0	0	0	0	0
CRESTMORE HEIGHTS MUTUAL WATER COMPANY	67	63	65	61	58	63	0	0	0	0	0	0
EASTERN MUNICIPAL WATER DISTRICT	3	1	0	0	0	1	0	0	0	0	0	0
EMPIRE WATER						0	575	533	475	456	503	508
GROSS, DALE P.	0	0	0	0	0	0	0	0	0	0	0	0
GRUBBS, V. W.	45	40	51	38	39	43	0	0	0	0	0	0
HEYMING, FRANK & LUCY						0	0	1	13	13	13	8
HUNTER ENGINEERING COMPANY	0	0	0	31	188	44	0	0	0	0	0	0
JOHNSON, TRUMAN	274	218	252	191	254	238	0	0	0	0	0	0
JURUPA COMMUNITY SERVICES DISTRICT	1,003	1,068	1,056	1,146	1,414	1,137	603	581	402	509	532	525
LA CASA CONTENTA MOTEL	0	0	0	0	0	0	0	0	0	0	0	0
LORING RANCH 31503 LP	5	5	5	5	5	5	0	0	0	0	0	0
MADISON, ERIN	1,167	1,485	1,196	991	1,443	1,256	0	0	0	0	0	0
MARTIN LINEN (TRI-CITY LINEN SUPPLY CO)	30	34	38	35	31	34	88	77	64	71	55	71
MARTIN, KENNETH ALLAN	0	0	0	0	0	0	0	0	0	0	0	0
MASTERCRAFT HOMES	987	987	987	987	987	987	0	0	0	0	0	0
MICHAEL, C.	354	354	354	354	354	354	0	0	0	0	0	0
MIPO CORP, DBA MISSION	73	73	73	73	73	73	0	0	0	0	0	0
PROPERTY ACQUISITION COMPANY	140	136	143	139	141	140	0	0	0	0	0	0
RIVERSIDE CEMENT COMPANY	1,067	1,080	2,702	2,434	2,205	1,898	2	1	1	57	1	12
RIVERSIDE COUNTY FLOOD CONTROL						0	1	2	2	2	1	2
RIVERSIDE COUNTY PARKS DEPARTMENT	2,240	2,240	2,240	2,240	2,240	2,240	340	402	352	521	532	429
RIVERSIDE HIGHLAND WATER CO	0	0	0	1,393	1,381	555	0	0	0	0	0	0
RIVERSIDE INDUSTRIAL PARK	315	315	224	209	174	247	0	0	0	0	0	0
RIVERSIDE THOROUGHBRED FARM					90	18	0	0	0	0	0	0
RIVERSIDE UNIFIED SCHOOL DISTRICT						0	18	18	19	21	10	17
RIVERSIDE, CITY OF	12,916	16,177	16,741	13,552	11,543	14,186	18,742	23,850	17,986	18,374	16,247	19,040
RIVERSIDE, CITY OF-GAGE CANAL	3,057	2,987	3,236	2,017	2,171	2,694	3,192	2,539	2,653	3,091	2,604	2,816
RIVINO WATER COMPANY	297	211	187	477	372	309	0	0	0	0	0	0

**WESTERN - SAN BERNARDINO WATERMASTER
TABLE 3
VERIFIED EXTRACTION, SUMMARY - FILED AND NON-FILED
RIVERSIDE SOUTH BASIN**

	-----BASE YEARS-----						-----CALENDAR YEAR EXTRACTIONS-----					
	1959	1960	1961	1962	1963	AVG	2008	2009	2010	2011	2012	AVG
ROCKY R RANCH	45	24	6	6	5	17	0	0	0	0	0	0
ROOS, CHARLES E.	0	200	0	0	0	40	0	0	0	0	0	0
ROSS, SAM	0	0	0	0	0	0	0	0	0	0	0	0
RUBIDOUX C.S.D.	1,006	1,112	1,389	1,179	1,219	1,181	6,702	6,609	6,285	6,600	6,787	6,597
SCHWAB, A. M.	110	88	42	11	12	53	0	0	0	0	0	0
SCOPE CORPORATION	116	90	135	199	100	128	0	0	0	0	0	0
STOKER, GEORGE	158	165	159	165	134	156	0	0	0	0	0	0
TAYLOR, WALTER & BARBARA	0	0	0	30	15	9	0	0	0	0	0	0
UNIVERSAL FOREST PRODUCTS						0	0	0	0	0	0	0
UNIVERSITY OF CALIFORNIA, REGENTS OF	131	283	370	94	227	221	0	0	0	0	0	0
VICTORIA COUNTRY CLUB	0	0	0	0	0	0	426	435	400	422	379	412
VON KANEL, ALFRED	83	87	94	94	78	87	0	0	0	0	0	0
WATERMAN, ALLEN H	25	33	16	0	0	15	0	0	0	0	0	0
WHITE SULPHUR SPRINGS POOL	49	53	54	44	40	48	0	0	0	0	0	0
WIGHT, CHARLES H	76	0	0	0	0	15	0	0	0	0	0	0
ZIKE, VERA	53	37	47	20	18	35	0	0	0	0	0	0
TOTALS FOR ALL WELLS	26,826	30,770	33,218	29,298	28,057	29,634	31,219	35,541	29,090	30,528	28,049	30,885

TABLE NO. 4
TOTAL VERIFIED EXTRACTIONS FROM THE
RIVERSIDE BASIN AREA WITHIN RIVERSIDE COUNTY
FOR USE WITHIN RIVERSIDE COUNTY
DURING THE 5-YEAR BASE PERIOD ENDING IN 1963
AND FOR CALENDAR YEARS 1971 THROUGH THE CURRENT YEAR

TOTAL VERIFIED EXTRACTATIONS FROM THE
RIVERSIDE BASIN AREA WITHIN RIVERSIDE COUNTY
FOR USE WITHIN RIVERSIDE COUNTY
DURING THE 5-YEAR BASE PERIOD ENDING IN 1963
AND FOR CALENDAR YEARS 1971 THROUGH THE CURRENT YEAR
 (Quantities in Acre Feet)

Year	Extractions	Accumulated Extractions
1959	26,826	26,826
1960	30,770	57,596
1961	33,218	90,814
1962	29,298	120,112
1963	28,057	148,169
5-Yr. Avg.	29,634	
1971	30,942	30,942
1972	37,804	68,746
1973	33,094	101,840
1974	38,304	140,144
1975	28,285	168,429
1976	31,565	199,994
1977	28,226	228,220
1978	24,576	252,796
1979	25,512	278,308
1980	30,206	308,514
1981	30,243	338,757
1982	20,365	359,122
1983	22,991	382,113
1984	32,466	414,579
1985	23,970	438,549
1986	24,549	463,098
1987	24,202	487,300
1988	24,470 ^{1) 3)}	511,770
1989	34,417 ^{2) 3)}	546,187
1990	31,760 ³⁾	577,947
1991	29,364 ⁴⁾	607,311
1992	26,538 ⁴⁾	633,849
1993	26,505	660,354
1994	28,125	688,479
1995	22,580	711,059
1996	24,906	735,965
1997	29,128	765,093
1998	28,558	793,651
1999	33,837 ⁶⁾	827,488
2000	32,263 ⁶⁾	859,751
2001	33,656 ⁶⁾	893,407
2002	31,013 ⁶⁾	924,420
2003	30,957 ⁶⁾	955,377
2004	35,530 ⁶⁾	990,907
2005	32,737 ^{5) 6)}	1,023,644

Same as Table 56, Volume 5.

- 1) Corrected during 1989 verification (Michael C.).
 - 2) Corrected during 1990 verification (Riv. Cement 60-1, C of R Garner T&G, 1st St).
 - 3) Corrected during 1991 verification (Riv.Co Pk Edmund, wrong meter # for 5 yrs).
 - 4) Corrected during 1993 verification (Riv Cement 88-1).
 - 5) Corrected during 2006 verification (JCSD #21).
- 1999 thru 2005 reduced by 45 af/yr for Hunter Engineering #3 well

TOTAL VERIFIED EXTRACTIONS FROM THE
RIVERSIDE BASIN AREA WITHIN RIVERSIDE COUNTY
FOR USE WITHIN RIVERSIDE COUNTY
DURING THE 5-YEAR BASE PERIOD ENDING IN 1963
AND FOR CALENDAR YEARS 1971 THROUGH THE CURRENT YEAR
 (Quantities in Acre Feet)

Year	Extractions	Accumulated Extractions
1959	26,826	26,826
1960	30,770	57,596
1961	33,218	90,814
1962	29,298	120,112
1963	28,057	148,169
5-Yr. Avg.	29,634	
2006	31,026	1,054,670
2007	38,237	1,092,907
2008	31,205 1)	1,124,112
2009	35,519	1,159,631
2010	29,077 2)	1,188,708
2011	30,510	1,219,218
2012	28,049	1,247,267
2013		
2014		
2015		
2016		
2017		
2018		
2019		
2020		
2021		
2022		
2023		
2024		
2025		
2026		
2027		
2028		
2029		
2030		
2031		
2032		
2033		
2034		
2035		
2036		
2037		
2038		
2039		
2040		

Same as Table 56, Volume 5.

1) Starting with 2008, this value is production less RPU blowoff amounts
 2) bad link corrected during 2011 verification work

**WESTERN - SAN BERNARDINO WATERMASTER
FOR**

WESTERN MUNICIPAL WATER DISTRICT et al.

vs.

EAST SAN BERNARDINO COUNTY WATER DISTRICT et al.

CASE NO. 78426 - COUNTY OF RIVERSIDE

VOLUME 5 - 2012

DISTRIBUTION OF EXTRACTATIONS

1. EXTRACTATIONS BY PLAINTIFFS FROM SAN BERNARDINO BASIN AREA.
2. EXTRACTION BY SAN BERNARDINO AND RIVERSIDE COUNTY ENTITIES FROM COLTON BASIN AREA FOR USE WITHIN EACH COUNTY.
3. EXTRACTATIONS BY SAN BERNARDINO AND RIVERSIDE COUNTY ENTITIES FROM RIVERSIDE BASIN AREA IN SAN BERNARDINO COUNTY FOR USE WITHIN EACH COUNTY.
4. EXTRACTION BY RIVERSIDE COUNTY ENTITIES FROM RIVERSIDE BASIN IN RIVERSIDE COUNTY.
5. SUMMARY OF EXTRACTATIONS FROM SAN BERNARDINO BASIN AREA, COLTON BASIN AREA, RIVERSIDE BASIN AREA IN SAN BERNARDINO COUNTY, AND RIVERSIDE BASIN AREA IN RIVERSIDE COUNTY FOR USE IN RIVERSIDE COUNTY.

**ANNUAL ACCOUNTING
2012**

April 1, 2014

WATERMASTER

*Douglas D. Headrick
John V. Rossi*

REPORT OF WATERMASTER

Western Municipal Water District of Riverside County, et al.
Plaintiffs

vs.

East San Bernardino County Water District, et al.
Defendants

Superior Court of Riverside County

Case No. 78426

VOLUME 5-2012

Distribution of Extractions

1. EXTRACTIONS BY PLAINTIFFS FROM SAN BERNARDINO BASIN AREA.
2. EXTRACTIONS BY SAN BERNARDINO AND RIVERSIDE COUNTY ENTITIES FROM COLTON BASIN AREA FOR USE WITHIN EACH COUNTY.
3. EXTRACTIONS BY SAN BERNARDINO AND RIVERSIDE COUNTY ENTITIES FROM RIVERSIDE BASIN AREA IN SAN BERNARDINO COUNTY FOR USE WITHIN EACH COUNTY
4. EXTRACTIONS BY RIVERSIDE COUNTY ENTITIES FROM RIVERSIDE BASIN IN RIVERSIDE COUNTY.
5. SUMMARY OF EXTRACTIONS FROM SAN BERNARDINO BASIN AREA, COLTON BASIN AREA, RIVERSIDE BASIN IN SAN BERNARDINO COUNTY, AND RIVERSIDE BASIN IN RIVERSIDE COUNTY FOR USE IN RIVERSIDE COUNTY.

ANNUAL ACCOUNTING

2012

April 1, 2014

WATERMASTER

Douglas D. Headrick
John V. Rossi

VOLUME 5-2012

DISTRIBUTION OF EXTRACTIONS

The distribution of the verified extractions by the Plaintiffs and Riverside County entities from the San Bernardino Basin Area, Colton Basin Area, and Riverside Basin Area for the five calendar years ending with 1963 and the ensuing years 1964 through 1970 was presented in the Report of Watermaster, Volume 5, dated June 1972. That volume also included the distribution of extractions from the Colton Basin Area and that portion of the Riverside Basin Area within San Bernardino County made by San Bernardino county entities for the five calendar years ending with 1963 and the year of 1970.

The distribution of extractions in calendar years 1971, 1972, and 1973 was presented in separate reports as updates to the original Volume 5 dated June 1972. Changes in the distribution systems of the various water entities during the period 1971 through 1973, necessitated several revisions of the original Volume 5. Therefore, Volume 5 for calendar year 1974 was completely revised and updated to reflect these changes. As a result Volume 5 dated August 1976 now represents the most recent complete report on distribution of extractions including descriptions of each water system.

This report, Volume 5-2012 shows the distribution of extractions for calendar years 1971 through 2012 and is supplementary to the Volume 5 dated August 1976. Detailed computations and tables are used to show the distribution of extractions from Colton and Riverside Basin Areas by both Riverside and San Bernardino County entities and the Plaintiffs' extractions from the San Bernardino Basin Area.

The following Table of Contents lists the tables used to show the distribution of extractions. Tables No.5 through No.7 and No.23 through No.27 did not require updating and therefore they are not included in this volume. These tables are presented in Volume 5 - 1974.

Tables No.5 through No.7 do not require updating because Ownership changes within the service area of the Trujillo Water Company have occurred and since 1965 the entire service area of the Trujillo Water Company is within Riverside County and is served by water extracted from the Garner Well, situated in Riverside County and owned by the City of Riverside.

Tables No.9, No.10, No.11, No.14 & No.16 also no longer require updating due to changes in methods of operation of the various water suppliers.

Tables No.23 through No.27 do not require updating because they contain data for years prior to 1963. These tables show the distribution of the Riverside Highland Water Company production from the San Bernardino Basin based on the assumption that 50 percent of the delivery was made in each county. This assumption results in the distribution shown on Table No. 27 and is identical with Table B-1, Appendix "B" of the Judgment. Following the settlement of the suit and the filing of the Judgment, the actual water deliveries in Riverside County were provided by the Riverside Highland Water Company. This information has been used by the Watermaster for the period 1964 through the current year, and results in the data shown in Table No. 31-A. Starting with calendar year 1990, Tables No.28-31 were replaced by Table No.23R in an effort to better quantify the distribution of extractions for Riverside Highland Water Company.

TABLE OF CONTENTS

Page

MAP 1

MAP FOR VOLUME 5 1

TABLES 1-14 CITY OF RIVERSIDE PRODUCTION AND DISTRIBUTION

TABLE NO. 1

CITY OF RIVERSIDE WATER PRODUCTION BUNKER HILL BASIN,
DOMESTIC & IRRIGATION DIVISIONS INCLUDING FORMER
RIVERSIDE WATER CO. IN SAN BERNARDINO BASIN AREA 3

TABLE NO. 2

CITY OF RIVERSIDE WATER PRODUCTION COLTON BASIN & RIVERSIDE
BASIN IN SAN BERNARDINO CO., DOMESTIC & IRRIGATION DIVISIONS
INCLUDING FORMER RIVERSIDE WATER CO 11

TABLE NO. 3

CITY OF RIVERSIDE DOMESTIC & IRRIGATION DIVISIONS,
DELIVERIES MADE FROM WATER PRODUCED FROM THE BUNKER
HILL, COLTON AND RIVERSIDE GROUND WATER BASINS
SITUATED IN SAN BERNARDINO CO. 19

TABLE NO. 4

CITY OF RIVERSIDE WATER DELIVERIES TO TRUJILLO WATER CO.
IN SAN BERNARDINO AND RIVERSIDE COUNTIES 22

TABLES NO. 5,6 & 7 - See Volume 5-1974 for data 24

TABLE NO. 8

CITY OF RIVERSIDE JURUPA DITCH CO. WATER PRODUCTION FROM
RIVERSIDE BASIN IN SAN BERNARDINO COUNTY FOR USE IN
SAN BERNARDINO CO. AND EXPORT TO RIVERSIDE CO.. 25

TABLE NO. 9

CITY OF RIVERSIDE IRRIGATION DIVISION, PRODUCTION DELIVERED
TO FORMER RIVERSIDE WATER COMPANY CANAL AND DISTRIBUTION OF
PRODUCTION DELIVERED TO SALAZAR WATER CO. 27

CITY OF RIVERSIDE IRRIGATION DIVISION, PRODUCTION DELIVERED TO FORMER RIVERSIDE WATER COMPANY CANAL AND DISTRIBUTION OF PRODUCTION DELIVERED TO SO. CALIF. EDISON CO. HIGHGROVE POWER PLANT 28

TABLE NO. 11

CITY OF RIVERSIDE DOMESTIC & IRRIGATION DIVISIONS, WATER PRODUCTION & DELIVERIES FROM COLTON BASIN-WATER PRODUCTION FROM COLTON GROUND WATER BASIN IN SAN BERNARDINO COUNTY AND DELIVERIES OF PRODUCTION MADE NORTH OF THE COUNTY LINE IN SAN BERNARDINO COUNTY AND SOUTH OF THE COUNTY LINE IN RIVERSIDE COUNTY 29

TABLE NO. 12

CITY OF RIVERSIDE DOMESTIC & IRRIGATION DIVISIONS, WATER PRODUCTION & DELIVERIES FROM THE RIVERSIDE BASIN-WATER PRODUCTION FROM THAT PORTION OF THE RIVERSIDE GROUND WATER BASIN SITUATED NORTH OF THE COUNTY LINE IN SAN BERNARDINO COUNTY AND DELIVERIES OF PRODUCTION MADE NORTH OF THE COUNTY LINE IN SAN BERNARDINO COUNTY AND SOUTH OF THE RIVERSIDE COUNTY LINE. 30

TABLE NO. 13

CITY OF RIVERSIDE WATER PRODUCTION FROM SAN BERNARDINO BASIN AREA AND DELIVERIES WITHIN SAN BERNARDINO COUNTY AND EXPORT TO RIVERSIDE COUNTY 33

TABLE NO. 14

CITY OF RIVERSIDE AND UNIVERSITY OF CALIFORNIA EXTRactions FROM BUNKER HILL BASIN IN SAN BERNARDINO BASIN AREA 35

TABLES 15-18 GAGE CANAL WATER PRODUCTION AND DISTRIBUTION

TABLE NO. 15

THE GAGE CANAL COMPANY WATER PRODUCTION FROM BUNKER HILL BASIN, RIVERSIDE BASIN IN SAN BERNARDINO COUNTY AND RIVERSIDE BASIN IN RIVERSIDE COUNTY 37

<u>TABLE NO. 16</u>	<u>Page</u>
THE GAGE CANAL COMPANY WATER PRODUCTION FROM BUNKER HILL BASIN DELIVERED IN SAN BERNARDINO COUNTY & RIVERSIDE COUNTY TO EAST RIVERSIDE WATER COMPANY	41

<u>TABLE NO. 17</u>	
THE GAGE CANAL COMPANY WATER PRODUCTION FROM BUNKER HILL AND RIVERSIDE BASINS SITUATED IN SAN BERNARDINO COUNTY WITH DELIVERIES MADE IN SAN BERNARDINO COUNTY & EXPORTS TO RIVERSIDE COUNTY	42

<u>TABLE NO. 18</u>	
GAGE CANAL WATER PRODUCTION FROM SAN BERNARDINO BASIN AREA AND DELIVERIES WITHIN SAN BERNARDINO COUNTY AND EXPORTS TO RIVERSIDE COUNTY FOR BASE PERIOD 1959-1963 AND SUBSEQUENT YEARS	45

TABLES 19-31A RIVERSIDE HIGHLAND WATER COMPANY PRODUCTION AND DISTRIBUTION

<u>TABLE NO. 19</u>	
RIVERSIDE HIGHLAND WATER COMPANY WATER PRODUCTION FROM LYTLE AND BUNKER HILL BASINS IN SAN BERNARDINO BASIN AREA	48

<u>TABLE NO. 20</u>	
RIVERSIDE HIGHLAND WATER CO. WATER PRODUCTION FROM COLTON BASIN	50

<u>TABLE NO. 21</u>	
RIVERSIDE HIGHLAND WATER CO. WATER PRODUCTION FROM RIVERSIDE BASIN IN SAN BERNARDINO AND RIVERSIDE COUNTIES	52

<u>TABLE NO. 22</u>	
RIVERSIDE HIGHLAND WATER COMPANY WATER SUPPLY FROM OTHER COMPANIES AND RIVERSIDE HIGHLAND CO. PRODUCTION	54

<u>TABLE NO. 23, 24, 25, 26 & 27</u> - See Volume 5-1974 for data	56
---	----

TABLE NO. 23R

Page

RIVERSIDE HIGHLAND WATER COMPANY DISTRIBUTION OF EXTRACTATIONS. . 57
Replaces Tables 28, 29, 30, 31 after 1989.

TABLE NO. 28

RIVERSIDE HIGHLAND WATER COMPANY IRRIGATION AND DOMESTIC
DELIVERIES AND PRODUCTION REQUIRED IN RIVERSIDE & SAN
BERNARDINO COUNTIES 61

TABLE NO. 29

RIVERSIDE HIGHLAND WATER COMPANY WATER PRODUCTION SHOWN ON
RECORDATION FILING DELIVERED FOR IRRIGATION & DOMESTIC USES
WITHIN BOTH RIVERSIDE AND SAN BERNARDINO COUNTIES 62

TABLE NO. 30

RIVERSIDE HIGHLAND WATER COMPANY WATER PRODUCTION FROM LYTLE,
BUNKER HILL, COLTON & RIVERSIDE BASINS IN SAN BERNARDINO AND
RIVERSIDE COUNTIES AND THE DELIVERY OF THE PRODUCTION IN SAN
BERNARDINO AND RIVERSIDE COUNTIES 63

TABLE NO. 31

RIVERSIDE HIGHLAND WATER COMPANY WATER PRODUCTION FROM
LYTLE, BUNKER HILL, COLTON & RIVERSIDE BASINS IN SAN
BERNARDINO AND RIVERSIDE COUNTIES AND THE DELIVERY OF
THE PRODUCTION IN SAN BERNARDINO & RIVERSIDE COUNTIES 66

TABLE NO. 31-A

TOTAL PRODUCTION BY RIVESIDE HIGHLAND WATER COMPANY
FROM THE SAN BERNARDINO BASIN AREA (INCLUDES LYTLE AND
BUNKER HILL BASINS) AS DELIVERED IN SAN BERNARDINO AND
RIVERSIDE COUNTIES 67

TABLE NO. 31-B - Not required for updating after 1970 69

**TABLES 32-34 MEEKS AND DALEY WATER COMPANY WATER PRODUCTION
AND DISTRIBUTION**

TABLE NO. 32

MEEKS & DALEY WATER COMPANY AND AGUA MANSA WATER COMPANY
WATER PRODUCTION FROM THE SAN BERNARDINO BASIN AREA AND
THE COLTON BASIN AREA. 71

<u>TABLE NO. 33</u>	<u>Page</u>
MEEKS & DALEY WATER COMPANY AND AGUA MANSA WATER COMPANY WATER PRODUCTION FROM THE SAN BERNARDINO BASIN AREA AND THE COLTON BASIN AREA DELIVERED IN SAN BERNARDINO COUNTY AND EXPORTED TO RIVERSIDE COUNTY	73

<u>TABLE NO. 34</u>	
MEEKS & DALEY WATER COMPANY WATER PRODUCTION FROM SAN BERNARDINO BASIN AREA AND DELIVERIES WITHIN SAN BERNARDINO COUNTY AND EXPORT TO RIVERSIDE COUNTY	75

**TABLES 35-36 REGENTS OF THE UNIVERSITY OF CALIFORNIA WATER
PRODUCTION AND DISTRIBUTION**

<u>TABLE NO. 35</u>	
UNIVERSITY OF CALIFORNIA WATER PRODUCTION FROM BUNKER HILL BASIN IN THE SAN BERNARDINO BASIN AREA AND EXPORT TO RIVERSIDE COUNTY	78

<u>TABLE NO. 36</u>	
UNIVERSITY OF CALIFORNIA WATER PRODUCTION FROM SAN BERNARDINO BASIN AREA AND EXPORT TO RIVERSIDE COUNTY	80

TABLES 36A-36E PLAINTIFFS SBBA PRODUCTION AND DELIVERIES

<u>TABLE NO. 36-A</u>	
EXTRACTIONS BY PLAINTIFFS FROM THE SAN BERNARDINO BASIN AREA THROUGH THE CURRENT YEAR	83

<u>TABLE NO. 36-B</u>	
TOTAL PLAINTIFF EXTRACTIONS FROM SAN BERNARDINO BASIN AREA	93

<u>TABLE NO. 36-C</u>	
PLAINTIFF EXTRACTIONS FROM SAN BERNARDINO BASIN AREA DELIVERIES IN SAN BERNARDINO BASIN AREA	95

<u>TABLE NO. 36-D</u>	<u>Page</u>
PLAINTIFF EXTRACTIONS FROM SAN BERNARDINO BASIN AREA DELIVERIES IN COLTON & RIVERSIDE BASINS IN SAN BERNARDINO COUNTY	97

<u>TABLE NO. 36-E</u>	
PLAINTIFF EXTRACTIONS FROM SAN BERNARDINO BASIN AREA DELIVERIES OUTSIDE SAN BERNARDINO VALLEY	99

TABLES 37-39A COLTON BASIN PRODUCTION AND DELIVERIES

<u>TABLE NO. 37</u>	
RIVERSIDE ENTITIES PRODUCTION AND DELIVERY FROM COLTON BASIN AREA FOR USE WITHIN SAN BERNARDINO COUNTY AND RIVERSIDE COUNTY	102

<u>TABLE NO. 38</u>	
SAN BERNARDINO ENTITIES PRODUCTION FROM COLTON BASIN AREA FOR USE WITHIN SAN BERNARDINO COUNTY	108

<u>TABLE NO. 38-A</u>	
COLTON BASIN EXTRACTIONS BY RIVERSIDE ENTITIES AND PLACE OF USE	110

<u>TABLE NO. 39</u>	
VERIFIED EXTRACTIONS FROM COLTON BASIN AREA BY SAN BERNARDINO AND RIVERSIDE COUNTY ENTITIES FOR USE WITHIN EACH COUNTY	112

<u>TABLE NO. 39-A</u>	
GROUND WATER EXTRACTIONS BY RIVERSIDE ENTITIES FROM COLTON BASIN AREA FOR USE IN RIVERSIDE & SAN BERNARDINO COUNTIES FROM 1971 THROUGH CURRENT YEAR	122

TABLES 40-54 RIVERSIDE NORTH BASIN PRODUCTION AND DELIVERIES

<u>TABLE NO. 40</u>	<u>Page</u>
RIVERSIDE CEMENT COMPANY, WATER PRODUCTION FROM RIVERSIDE GROUND WATER BASIN SITUATED WITHIN SAN BERNARDINO COUNTY	133
<u>TABLE NO. 41</u>	
RIVERSIDE CEMENT COMPANY, WATER PRODUCTION FROM RIVERSIDE GROUND WATER BASIN WITHIN SAN BERNARDINO COUNTY FOR PERIOD 1971 THROUGH CURRENT YEAR AND PRODUCTION DELIVERED IN RIVERSIDE AND SAN BERNARDINO COUNTIES	134
<u>TABLE NO. 42</u>	
CITY OF RIVERSIDE IRRIGATION & DOMESTIC DIVISIONS WATER PRODUCTION FROM RIVERSIDE GROUND WATER BASIN WITHIN SAN BERNARDINO COUNTY FOR PERIOD 1971 THROUGH CURRENT YEAR AND PRODUCTION DELIVERED IN RIVERSIDE AND SAN BERNARDINO COUNTIES.	135
<u>TABLE NO. 43</u>	
CITY OF RIVERSIDE IRRIGATION & DOMESTIC DIVISIONS, GAGE CANAL COMPANY, WATER PRODUCTION FROM RIVERSIDE GROUND WATER BASIN WITHIN SAN BERNARDINO COUNTY FOR PERIOD 1971 THROUGH CURRENT YEAR, AND PRODUCTION DELIVERED IN RIVERSIDE AND SAN BERNARDINO COUNTIES.	137
<u>TABLE NO. 44</u>	
INTER COUNTY WATER COMPANY WATER PRODUCTION FROM RIVERSIDE GROUND WATER BASIN WITHIN SAN BERNARDINO COUNTY FOR PERIOD 1971 THROUGH CURRENT YEAR AND PRODUCTION DELIVERED IN RIVERSIDE AND SAN BERNARDINO COUNTIES	139
<u>TABLE NO. 45 B</u>	
JURUPA WATER COMPANY WATER PRODUCTION FROM RIVERSIDE GROUND WATER BASIN WITHIN SAN BERNARDINO COUNTY FOR PERIOD 1971 THROUGH CURRENT YEAR AND PRODUCTION DELIVERED IN RIVERSIDE AND SAN BERNARDINO COUNTIES	141

LA SIERRA WATER COMPANY WATER PRODUCTION FROM COLTON BASIN AND THAT PART OF RIVERSIDE BASIN LOCATED WITHIN SAN BERNARDINO COUNTY 143

TABLE NO. 47

LA SIERRA WATER COMPANY WATER PRODUCTION FROM COLTON AND RIVERSIDE BASIN SITUATED WITHIN SAN BERNARDINO COUNTY WITH DELIVERIES IN SAN BERNARDINO COUNTY AND EXPORTS TO RIVERSIDE COUNTY. 146

TABLE NO. 48

LA SIERRA WATER CO. WATER PRODUCTION FROM RIVERSIDE GROUND WATER BASIN WITHIN SAN BERNARDINO COUNTY FOR PERIOD 1971 THROUGH CURRENT YEAR AND PRODUCTION DELIVERED IN RIVERSIDE AND SAN BERNARDINO COUNTIES 147

TABLE NO. 49

RIVERSIDE HIGHLAND WATER COMPANY WATER PRODUCTION FROM RIVERSIDE GROUND WATER BASIN WITHIN SAN BERNARDINO COUNTY FOR PERIOD 1971 THROUGH CURRENT YEAR AND PRODUCTION DELIVERED IN RIVERSIDE AND SAN BERNARDINO COUNTIES 148

TABLE NO. 50

TEMESCAL WATER CO. WATER PRODUCTION FROM RIVERSIDE GROUND WATER BASIN WITHIN SAN BERNARDINO COUNTY FOR PERIOD 1971 THROUGH CURRENT YEAR AND PRODUCTION DELIVERED IN RIVERSIDE AND SAN BERNARDINO COUNTIES. 150

TABLE NO. 51

WEST RIVERSIDE 350 INCH WATER COMPANY WATER PRODUCTION FROM RIVERSIDE GROUND WATER BASIN WITHIN SAN BERNARDINO COUNTY FOR PERIOD 1971 THROUGH CURRENT YEAR 152

TABLE NO. 52

GROUND WATER PRODUCTION FROM THAT PART OF THE RIVERSIDE GROUND WATER BASIN SITUATED WITHIN SAN BERNARDINO COUNTY, A PART IS USED IN SAN BERNARDINO COUNTY AND THE REMAINDER EXPORTED TO RIVERSIDE COUNTY DURING CALENDAR YEARS 1971 THROUGH CURRENT YEARS. 154

TABLE NO. 52-A

Page

GROUND WATER PRODUCTION FROM THAT PART OF RIVERSIDE
GROUND WATER BASIN SITUATED WITHIN SAN BERNARDINO COUNTY,
A PART OF WHICH IS USED IN SAN BERNARDINO COUNTY AND THE
REMAINDER EXPORTED TO RIVERSIDE COUNTY DURING THE CALENDAR
YEARS 1971 THROUGH CURRENT YEAR. 160

TABLE NO. 53

SAN BERNARDINO ENTITIES PRODUCTION FROM RIVERSIDE BASIN
AREA WITHIN SAN BERNARDINO COUNTY FOR THE PERIOD 1971
THROUGH CURRENT YEAR FOR USE WITHIN SAN BERNARDINO COUNTY. . . 170

TABLE NO. 54

TOTAL VERIFIED EXTRACTATIONS FROM THAT PORTION OF THE RIVERSIDE
BASIN SITUATED IN SAN BERNARDINO COUNTY FOR THE PERIOD 1971
THROUGH CURRENT YEAR BY SAN BERNARDINO AND RIVERSIDE COUNTY
ENTITIES FOR USE WITHIN EACH COUNTY. 172

TABLES 55-56 RIVERSIDE SOUTH BASIN PRODUCTION

TABLE NO. 55

This table has not been updated after 1970 182

TABLE NO. 56

TOTAL VERIFIED EXTRACTATIONS BY RIVERSIDE ENTITIES FROM THE
RIVERSIDE BASIN AREA WITHIN RIVERSIDE COUNTY FOR USE WITHIN
RIVERSIDE COUNTY 183

TABLE 57 SUMMARY OF EXTRACTATIONS FOR USE IN RIVERSIDE COUNTY

TABLE NO. 57

SUMMARY OF EXTRACTATIONS FROM SAN BERNARDINO BASIN AREA,
COLTON BASIN AREA, RIVERSIDE BASIN AREA IN SAN BERNARDINO
COUNTY, AND RIVERSIDE BASIN AREA IN RIVERSIDE COUNTY FOR
USE IN RIVERSIDE COUNTY 186

DIAGRAM B RIVERSIDE HIGHLAND WATER PRODUCTION AND DISTRIBUTION FLOW CHARTS









DIAGRAM B

Page

RIVERSIDE HIGHLAND WATER COMPANY DIAGRAM ILLUSTRATING THE PRODUCTION AND DISTRIBUTION NORTH AND SOUTH OF RIVERSIDE-SAN BERNARDINO CO. LINE, YEARS 1971 THROUGH CURRENT YEAR 189


MAP 1 VOLUME 5

Legend

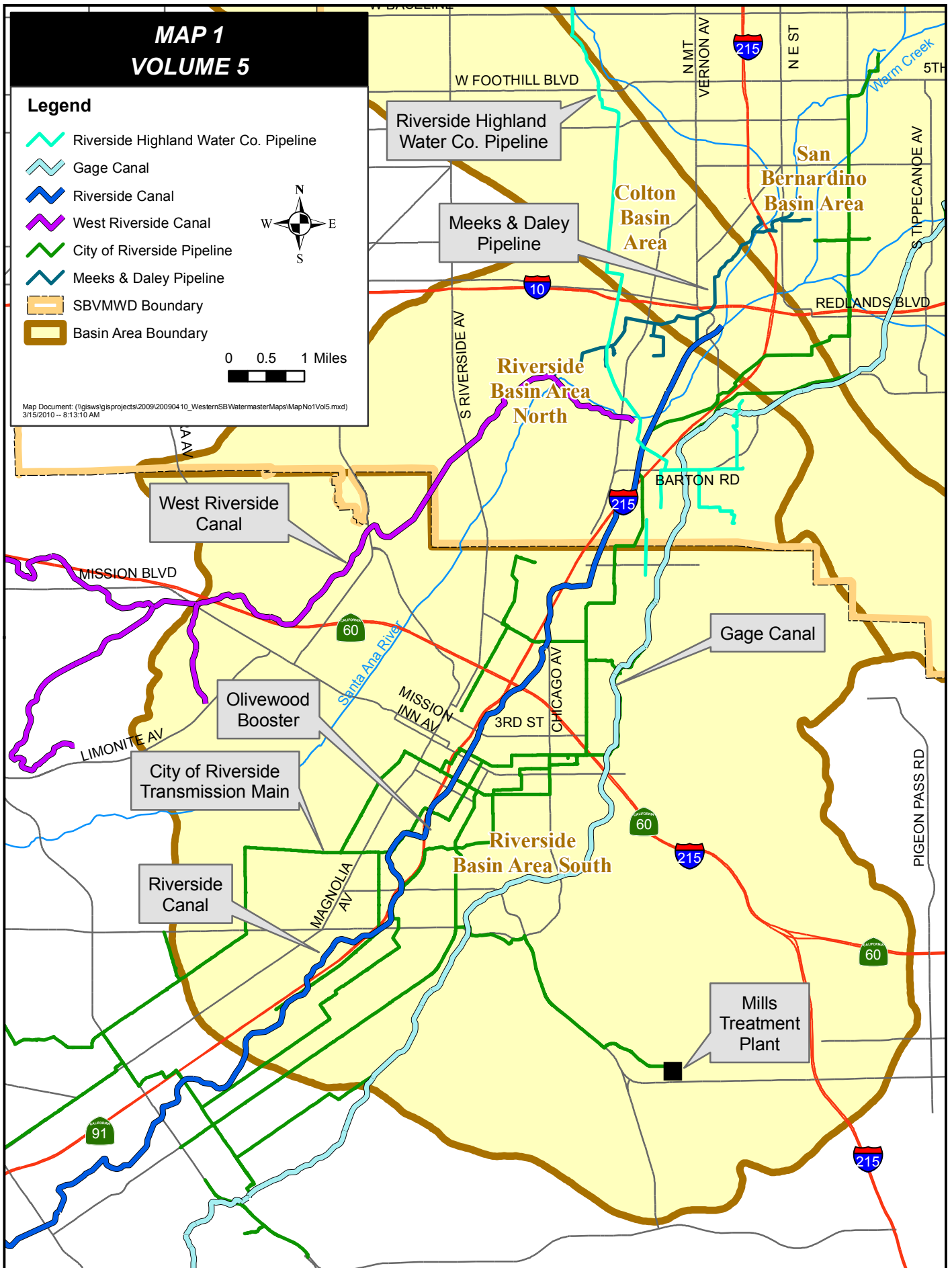
-  Riverside Highland Water Co. Pipeline
-  Gage Canal
-  Riverside Canal
-  West Riverside Canal
-  City of Riverside Pipeline
-  Meeks & Daley Pipeline
-  SBVMWD Boundary
-  Basin Area Boundary



0 0.5 1 Miles



Map Document: (\\gisw\gis\projects\2009\20090410_WesternSBWatermaster\Maps\MapNo1Vol5.mxd)
3/15/2010 -- 8:13:10 AM



Volume 5

Tables 1-14

City of Riverside water
production and distribution

TABLE NO. 1

CITY OF RIVERSIDE WATER PRODUCTION
BUNKER HILL BASIN
DOMESTIC & IRRIGATION DIVISIONS INCLUDING FORMER RIVERSIDE WATER CO.
IN SAN BERNARDINO BASIN AREA

(Quantities in Acre Feet by Calendar Year)

Ln #	Local Designation	State Well #	Recordation #	1971	1972	1973	1974	1975	1976	1977	1978	1979	1980	1981	1982
1	McCrary # 1	1S/4W-01B03S	3601457	0	0	0	0	0	0	0	0	0	0	0	0
2	McCrary # 2	1S/4W-01B02S	3601458	0	0	0	0	0	0	0	0	0	0	0	0
3	McCrary # 3	1S/4W-01B	3601459	0	0	0	0	0	0	0	0	0	0	0	0
4	McCrary # 4	1S/4W-01B	3601460	0	0	0	0	0	0	0	0	0	0	0	0
5	McCrary # 5	1S/4W-01B	3601461	0	0	0	0	0	0	0	0	0	0	0	0
6	Poole	1S/4W-01E01S	3601462	1,927	1,498	0	0	0	0	0	0	0	0	0	0
7	Stiles	1S/4W-02A03S	3601463	1,870	1,401	1,349	1,665	1,938	1,911	1,520	1,367	1,702	1,578	1,739	1,517
8	Scheuer	1S/4W-02L01S	3601489	568	525	83	527	560	406	633	442	658	570	366	183
9	Garner # 1	1S/4W-02P06S	3601464	755	566	392	958	1,029	598	448	546	654	602	753	742
10	Garner # 2	1S/4W-02Q03S	3601465	669	506	419	359	527	602	302	373	582	470	238	507
11	Garner # 3	1S/4W-02Q07S	3601466	0	0	0	0	0	0	0	0	0	0	0	0
12	Garner # 4	1S/4W-02Q06S	3601467	771	460	525	749	881	874	669	951	1,275	865	365	894
13	Garner # 5	1S/4W-02P01S	3601468	2,100	2,206	2,411	1,438	2,422	2,237	1,599	1,806	1,904	1,598	1,485	1,565
14	Paine Hot	1S/4W-22A01S	3601469	0	0	0	0	0	0	0	0	0	0	0	0
15	Thorn # 1 *	1S/4W-22G01S	3601016	-	-	-	-	-	-	-	-	-	-	-	-
16	Thorn # 2 **	1S/4W-22G15S	3601470	-	-	-	-	-	-	-	-	-	-	-	-
17	Thorn # 3	1S/4W-22G14S	3601471	502	94	0	0	1,077	31	0	0	0	0	0	266
18	Thorn # 4	1S/4W-22G11S	3601472	0	0	0	0	0	0	0	0	0	0	0	0
19	Thorn # 5	1S/4W-22G16S	3601473	359	0	0	0	494	0	0	0	0	0	0	16
20	Thorn # 6	1S/4W-22G18S	3601474	0	0	0	0	0	0	0	0	0	0	0	2
21	Thorn # 7	1S/4W-22G17S	3601475	0	0	0	0	0	0	0	0	0	0	0	7
22	Thorn # 8	1S/4W-22G19S	3601476	134	121	0	323	140	0	0	0	0	0	0	0
23	Thorn # 9	1S/4W-22B01S	3601477	0	0	0	0	0	0	0	0	0	0	0	0
24	Thorn # 10	1S/4W-22B03S	3601478	0	40	27	47	5	37	12	0	0	0	0	146
25	Thorn # 11	1S/4W-22B05S	3601479	0	0	0	0	0	0	0	0	0	0	0	0
26	Thorn # 12 **	1S/4W-22B07S	3601470-	1,162	1,054	502	1,345	976	909	743	776	582	578	64	708
27	a Warm Ck Rising Wtr.	1S/4W-21P	3601496	0	0	0	0	0	-	0	0	0	0	0	0
28															
29															
30	Sub Total	(Line 1 - 30)		10,817	8,471	5,708	7,411	10,049	7,605	5,926	6,261	7,357	6,261	5,010	6,553

o Abandoned &/or File Closed.

* Thorn No. 1 sold to C.E.P. (So Calif. Edison), in City production after 1958.

** Thorn # 12 replacement well for Thorn #2.

a Located in Colton Basin, see Volume 2.

+26 AF added to 1981 production as a correction to 1980 extraction

TABLE NO. 1

CITY OF RIVERSIDE WATER PRODUCTION
BUNKER HILL BASIN
DOMESTIC & IRRIGATION DIVISIONS INCLUDING FORMER RIVERSIDE WATER CO.
IN SAN BERNARDINO BASIN AREA

(Quantities in Acre Feet by Calendar Year)

Ln #	Local Designation	State Well #	Recordation #	1983	1984	1985	1986	1987	1988	1989	1990	1991	1992	1993	1994	1995
1	o McCrary # 1	1S/4W-01B03S	3601457	0	0	0	0	0	0	0	0	0	0	0	0	0
2	o McCrary # 2	1S/4W-01B02S	3601458	0	0	0	0	0	0	0	0	0	0	0	0	0
3	o McCrary # 3	1S/4W-01B	3601459	0	0	0	0	0	0	0	0	0	0	0	0	0
4	o McCrary # 4	1S/4W-01B	3601460	0	0	0	0	0	0	0	0	0	0	0	0	0
5	o McCrary # 5	1S/4W-01B	3601461	0	0	0	0	0	0	0	0	0	0	0	0	0
6	Poole	1S/4W-01E01S	3601462	0	0	0	0	0	0	0	0	0	0	0	0	0
7	Stiles	1S/4W-02A03S	3601463	1,779	1,848	2,105	1,899	1,452	1,363	1,270	1,114	717	225	679	768	1,085
8	Scheuer	1S/4W-02L01S	3601489	37	159	436	655	76	451	231	131	347	553	826	220	368
9	Garner # 1	1S/4W-02P06S	3601464	376	1,026	595	808	836	867	594	775	760	769	723	556	681
10	Garner # 2	1S/4W-02Q03S	3601465	196	54	419	341	416	536	524	543	462	500	461	293	562
11	o Garner # 3	1S/4W-02Q07S	3601466	0	0	0	0	0	0	0	0	0	0	0	0	0
12	Garner # 4	1S/4W-02Q06S	3601467	74	185	895	668	744	842	644	746	0	0	0	0	0
13	Garner # 5	1S/4W-02P01S	3601468	1,602	1,639	1,292	1,942	1,805	2,224	2,027	2,024	1,713	1,701	1,388	1,172	1,835
14	o Paine Hot	1S/4W-22A01S	3601469	0	0	0	0	0	0	0	0	0	0	0	0	0
15	Thorn # 1 *	1S/4W-22G01S	3601016	-	-	-	-	-	-	-	-	-	-	-	-	-
16	o Thorn # 2 **	1S/4W-22G15S	3601470	-	-	-	-	-	-	-	-	-	-	-	-	-
17	Thorn # 3	1S/4W-22G14S	3601471	0	0	1,103	12	0	0	0	0	859	111	0	0	0
18	o Thorn # 4	1S/4W-22G11S	3601472	0	0	0	0	0	0	0	0	0	0	0	0	0
19	Thorn # 5	1S/4W-22G16S	3601473	0	0	525	6	0	0	0	0	487	61	100	1	0
20	Thorn # 6	1S/4W-22G18S	3601474	0	0	311	2	0	0	0	0	98	22	0	0	0
21	Thorn # 7	1S/4W-22G17S	3601475	0	0	322	2	0	0	0	0	93	0	0	0	0
22	Thorn # 8	1S/4W-22G19S	3601476	0	0	0	0	0	0	0	0	0	0	0	0	0
23	o Thorn # 9	1S/4W-22B01S	3601477	0	0	0	0	0	0	0	0	0	0	0	0	0
24	Thorn # 10	1S/4W-22B03S	3601478	144	0	0	0	0	46	28	19	155	203	90	7	1
25	Thorn # 11	1S/4W-22B05S	3601479	0	0	0	0	0	0	0	0	0	0	0	0	608
26	Thorn # 12 **	1S/4W-22B07S	3601470-	1,345	0	515	1,552	1,593	1,277	1,112	160	1,200	1,021	907	1,421	1,081
27	a Warm Ck Rising Wtr	1S/4W-21P	3601496	-	-	-	-	-	-	-	-	-	-	-	-	-
28																
29																
30	Sub Total	(Line 1 - 30)		5,553	4,911	8,518	7,887	6,922	7,606	6,430	5,512	6,891	5,166	5,174	4,438	6,221

o Abandoned &/or File Closed.

* Thorn No. 1 sold to C.E.P. (So Calif. Edison), in City production after 1958.

** Thorn # 12 replacement well for Thorn #2.

a Located in Colton Basin, see Volume 2.

TABLE NO. 1

CITY OF RIVERSIDE WATER PRODUCTION
BUNKER HILL BASIN
DOMESTIC & IRRIGATION DIVISIONS INCLUDING FORMER RIVERSIDE WATER CO.
IN SAN BERNARDINO BASIN AREA

(Quantities in Acre Feet by Calendar Year)

Ln #	Local Designation	State Well #	Recordation #	1996	1997	1998	1999	2000	2001	2002	2003	2004	2005	2006	2007	2008	2009	2010
1	o McCrary # 1	1S/4W-01B03S	3601457	-	-	-	-	-	-	-	-	-	-	-	-	-	-	-
2	o McCrary # 2	1S/4W-01B02S	3601458	-	-	-	-	-	-	-	-	-	-	-	-	-	-	-
3	o McCrary # 3	1S/4W-01B	3601459	-	-	-	-	-	-	-	-	-	-	-	-	-	-	-
4	o McCrary # 4	1S/4W-01B	3601460	-	-	-	-	-	-	-	-	-	-	-	-	-	-	-
5	o McCrary # 5	1S/4W-01B	3601461	-	-	-	-	-	-	-	-	-	-	-	-	-	-	-
6	Poole	1S/4W-01E01S	3601462	0	0	0	0	0	0	0	0	0	0	0	0	0	0	0
7	Stiles	1S/4W-02A03S	3601463	838	538	813	563	368	759	467	530	302	903	539	647	728	575	231
8	o Scheuer	1S/4W-02L01S	3601489	163	36	55	69	157	111	137	8	2	1	0	0	-	-	-
8A	Scheuer #2	1S/4W-02L01S	3603923	-	-	-	-	-	-	-	-	-	-	-	-	1,799	1,784	1,306
9	Garner # 1	1S/4W-02P06S	3601464	328	181	157	234	552	439	696	338	467	297	108	211	338	102	52
10	Garner # 2	1S/4W-02Q03S	3601465	170	67	131	93	266	774	780	5	110	10	0	0	0	0	0
11	o Garner # 3	1S/4W-02Q07S	3601466	-	-	-	-	-	-	-	-	-	-	-	-	-	-	-
12	Garner # 4	1S/4W-02Q06S	3601467	0	0	0	0	0	0	0	0	0	0	0	0	199	174	104
13	Garner # 5	1S/4W-02P01S	3601468	146	1,456	1,139	1,756	1,924	1,071	2,144	1,943	1,161	1,115	1,206	1,322	1,502	1,240	364
14	o Paine Hot	1S/4W-22A01S	3601469	-	-	-	-	-	-	-	-	-	-	-	-	-	-	-
15	Thorn # 1 *	1S/4W-22G01S	3601016	-	-	-	-	-	-	-	-	-	-	-	-	-	-	-
16	o Thorn # 2 **	1S/4W-22G15S	3601470	-	-	-	-	-	-	-	-	-	-	-	-	-	-	-
17	Thorn # 3	1S/4W-22G14S	3601471	0	0	0	0	0	0	23	0	0	0	0	0	0	0	0
18	o Thorn # 4	1S/4W-22G11S	3601472	-	-	-	-	-	-	-	-	-	-	-	-	-	-	-
19	Thorn # 5	1S/4W-22G16S	3601473	0	0	0	0	0	0	0	0	0	0	0	0	0	0	0
20	Thorn # 6	1S/4W-22G18S	3601474	0	0	0	0	0	0	0	0	0	0	0	0	0	0	0
21	Thorn # 7	1S/4W-22G17S	3601475	0	0	0	0	0	0	0	0	0	0	0	0	0	0	0
22	Thorn # 8	1S/4W-22G19S	3601476	0	0	0	0	0	0	10	0	0	0	0	0	0	0	0
23	o Thorn # 9	1S/4W-22B01S	3601477	-	-	-	-	-	-	-	-	-	-	-	-	-	-	-
24	Thorn # 10	1S/4W-22B03S	3601478	0	68	0	0	0	22	11	9	0	0	5	20	0	0	1
25	Thorn # 11	1S/4W-22B05S	3601479	268	418	0	0	0	186	161	1	0	13	25	19	0	0	1
26	Thorn # 12 **	1S/4W-22B07S	3601470-	1,660	1,296	300	851	1,231	833	1,098	834	890	749	980	873	570	38	264
27	a Warm Ck Rising Wtr.	1S/4W-21P	3601496	-	-	-	-	-	-	-	-	-	-	-	-	-	-	-
28																		
29																		
30	Sub Total	(Line 1 - 30)		3,573	4,060	2,595	3,566	4,498	4,195	5,527	3,668	2,932	3,088	2,863	3,092	5,136	3,913	2,323

o Abandoned &/or File Closed.
 * Thorn No. 1 sold to C.E.P. (So Calif. Edison), in City production after 1958.
 ** Thorn # 12 replacement well for Thorn #2.
 a Located in Colton Basin, see Volume 2.

TABLE NO. 1

CITY OF RIVERSIDE WATER PRODUCTION
BUNKER HILL BASIN
DOMESTIC & IRRIGATION DIVISIONS INCLUDING FORMER RIVERSIDE WATER CO.
IN SAN BERNARDINO BASIN AREA

(Quantities in Acre Feet by Calendar Year)

Ln #	Local Designation	State Well #	Recordation #	2011	2012	2013	2014	2015	2016	2017	2018	2019	2020	2021	2022	2023	2024	2025
1	o McCrary # 1	1S/4W-01B03S	3601457	-	-	-	-	-	-	-	-	-	-	-	-	-	-	-
2	o McCrary # 2	1S/4W-01B02S	3601458	-	-	-	-	-	-	-	-	-	-	-	-	-	-	-
3	o McCrary # 3	1S/4W-01B	3601459	-	-	-	-	-	-	-	-	-	-	-	-	-	-	-
4	o McCrary # 4	1S/4W-01B	3601460	-	-	-	-	-	-	-	-	-	-	-	-	-	-	-
5	o McCrary # 5	1S/4W-01B	3601461	-	-	-	-	-	-	-	-	-	-	-	-	-	-	-
6	o Poole	1S/4W-01E01S	3601462	0	0													
7	o Stiles	1S/4W-02A03S	3601463	581	262													
8	o Scheuer	1S/4W-02L01S	3601489	-	-	-	-	-	-	-	-	-	-	-	-	-	-	-
8A	Scheuer #2	1S/4W-02L01S	3603923	1,473	1,840													
9	o Garner # 1	1S/4W-02P06S	3601464	53	55													
10	o Garner # 2	1S/4W-02Q03S	3601465	0	0													
11	o Garner # 3	1S/4W-02Q07S	3601466	-	-	-	-	-	-	-	-	-	-	-	-	-	-	-
12	o Garner # 4	1S/4W-02Q06S	3601467	39	28													
13	o Garner # 5	1S/4W-02P01S	3601468	1,896	1,864													
14	o Paine Hot	1S/4W-22A01S	3601469	-	-	-	-	-	-	-	-	-	-	-	-	-	-	-
15	o Thorn # 1 *	1S/4W-22G01S	3601016	-	-	-	-	-	-	-	-	-	-	-	-	-	-	-
16	o Thorn # 2 **	1S/4W-22G15S	3601470	-	-	-	-	-	-	-	-	-	-	-	-	-	-	-
17	o Thorn # 3	1S/4W-22G14S	3601471	0	0													
18	o Thorn # 4	1S/4W-22G11S	3601472	-	-	-	-	-	-	-	-	-	-	-	-	-	-	-
19	o Thorn # 5	1S/4W-22G16S	3601473	0	0													
20	o Thorn # 6	1S/4W-22G18S	3601474	0	0													
21	o Thorn # 7	1S/4W-22G17S	3601475	0	0													
22	o Thorn # 8	1S/4W-22G19S	3601476	0	0													
23	o Thorn # 9	1S/4W-22B01S	3601477	-	-	-	-	-	-	-	-	-	-	-	-	-	-	-
24	o Thorn # 10	1S/4W-22B03S	3601478	0	0													
25	o Thorn # 11	1S/4W-22B05S	3601479	0	0													
26	o Thorn # 12 **	1S/4W-22B07S	3601470-	259	435													
27	a Warm Ck Rising Wtr.	1S/4W-21P	3601496	-	-	-	-	-	-	-	-	-	-	-	-	-	-	-
28																		
29																		
30	Sub Total	(Line 1 - 30)		4,301	4,484													

o Abandoned &/or File Closed.

* Thorn No. 1 sold to C.E.P. (So Calif. Edison), in City production after 1958.

** Thorn # 12 replacement well for Thorn #2.

a Located in Colton Basin, see Volume 2.

TABLE NO. 1

CITY OF RIVERSIDE WATER PRODUCTION
BUNKER HILL BASIN
DOMESTIC & IRRIGATION DIVISIONS INCLUDING FORMER RIVERSIDE WATER CO.
IN SAN BERNARDINO BASIN AREA

(Quantities in Acre Feet by Calendar Year)

Ln #	Local Designation	State Well #	Recordation #	1971	1972	1973	1974	1975	1976	1977	1978	1979	1980	1981	1982
31	o Cooley E	1S/4W-02P04S	3601220	0	0	0	0	0	0	0	0	0	0	0	0
32	o Cooley C	1S/4W-02P03S	3601224	0	0	0	0	0	0	0	0	0	0	0	0
33	o Cooley D	1S/4W-02P02S	3601225	0	0	0	0	0	0	0	0	0	0	0	0
34	o Cooley F	1S/4W-02L02S	3601226	0	0	0	0	0	0	0	0	0	0	0	0
35	o Cooley G	1S/4W-02N02S	3601227	0	0	0	0	0	0	0	0	0	0	0	0
36	Cooley H	1S/4W-11D02S	3601228	1,420	1,053	494	725	1,045	923	1,065	1,116	1,209	1,092	1,125	643
37	Cooley I	1S/4W-11D03S	3601229	3,580	2,606	4,089	3,743	3,328	3,367	2,756	2,318	2,884	2,513	3,086	2,017
38	o Cooley A	1S/4W-11D04S	3601232	-	-	-	-	-	-	-	-	-	-	-	-
39	o Cooley B	1S/4W-11D01S	3601432	-	-	-	-	-	-	-	-	-	-	-	-
40	o Raub # 1	1S/4W-14P02S	3601218	0	0	0	0	0	0	0	0	0	0	0	0
41	Raub # 2	1S/4W-23C02S	3601219	904	724	772	939	812	542	699	431	466	572	189	495
42	Raub # 4	1S/4W-23C03S	3601238	1,267	1,074	2,001	2,024	1,333	1,747	1,221	1,328	1,632	971	1,374	1,306
43	Raub # 3	1S/4W-14P06S	3601239	342	216	294	605	748	444	502	97	603	661	199	562
43a	Raub # 5	1S/4W-14N09S	3602484	0	1,353	2,465	3,731	1,544	2,966	2,277	2,697	3,335	2,306	1,861	2,249
44	o Byrne 1	1S/4W-22B02S	3601237	-	-	-	-	-	-	-	-	-	-	-	-
45	Warren # 3	1S/4W-22H03S	3601230	484	180	222	408	21	222	221	275	173	105	60	137
46	Warren # 2	1S/4W-22H01S	3601231	784	357	603	1,124	830	666	473	783	344	790	711	299
47	Warren # 1	1S/4W-22H04S	3601240	1,921	1,614	1,809	1,700	1,785	1,496	573	1,030	902	939	468	485
48	Warren # 4	1S/4W-22H02S	3601243	2,737	2,012	1,822	2,875	2,479	1,450	1,258	1,678	1,517	2,022	2,096	1,772
49	Hunt # 6 *	1S/4W-27A11S	3602771	225	209	249	547	241	22	542	393	397	1	1	77
50	o Hunt # 8 *	1S/4W-27A07S	3601241	-	-	-	-	-	-	-	-	-	-	-	-
51	o Hunt # 9 *	1S/4W-27A08S	3601242	-	-	-	-	-	-	-	-	-	-	-	-
52	Hunt # 10 *	1S/4W-27A09S	3602772	446	600	933	1,577	1,010	600	899	645	738	6	510	25
53	Hunt # 11 *	1S/4W-27A10S	3602773	0	0	0	0	10	31	462	0	0	0	0	86
54	Stewart # 21	1S/4W-27A13S	3601233	-	-	-	-	-	-	-	-	-	-	-	-
55	o Stewart # 19	1S/4W-27A19S	3601234	-	-	-	-	-	-	-	-	-	-	-	-
56	Stewart # 20	1S/4W-27H01S	3601431	12	5	32	11	13	4	26	3	4	3	4	1
56a	Raub # 6	1S/4W-14N10S	3602778	-	-	-	-	-	-	-	-	-	633	3,635	2,815
56b															
56c															
57	Sub Total	(Lines 31 - 56)		14,122	12,003	15,785	20,009	15,199	14,480	12,974	12,794	14,204	12,614	15,319	12,969
58															
59	Sub Total	(Lines 1 - 30)	Sheet 1	10,817	8,471	5,708	7,411	10,049	7,605	5,926	6,261	7,357	6,261	5,044	6,553
60	Sub Total	(Lines 31-57)		14,122	12,003	15,785	20,009	15,199	14,480	12,974	12,794	14,204	12,614	15,319	12,969
61	TOTAL PRODUCTION FROM BUNKER HILL BASIN			24,939	20,474	21,493	27,420	25,248	22,085	18,900	19,055	21,561	18,875	20,363	19,522
62															
63	Meeks & Daley	Sta. 59	3601887	0	0	0	275	1,649	1,895	1,848	1,385	1,231	1,650	2,496	1,471
64	Gage Canal Co.	30-1 & Gage Stewart		2,854	1,900	2,446	2,095	1,577	**	**	**	**	**	**	**
65	Total Lines 61+63+64	TOTAL WATER FOR DISTRIBUTION		27,793	22,374	23,939	29,790	28,474	23,980	20,748	20,440	22,792	20,525	22,859	20,993

* Figures shown for Hunt wells are for C of R use only, University of California reports its own usage.

** Gage 30-1 & Gage Stewart removed after covering of the Canal in 1975.

o Abandoned &/or File Closed.

TABLE NO. 1

**CITY OF RIVERSIDE WATER PRODUCTION
BUNKER HILL BASIN
DOMESTIC & IRRIGATION DIVISIONS INCLUDING FORMER RIVERSIDE WATER CO.
IN SAN BERNARDINO BASIN AREA**

(Quantities in Acre Feet by Calendar Year)

Ln #	Local Designation	State Well #	Recordation #	1983	1984	1985	1986	1987	1988	1989	1990	1991	1992	1993	1994	1995
31	o Cooley E	1S/4W-02P04S	3601220	0	0	0	0	0	0	0	0	0	0	0	0	0
32	o Cooley C	1S/4W-02P03S	3601224	0	0	0	0	0	0	0	0	0	0	0	0	0
33	o Cooley D	1S/4W-02P02S	3601225	0	0	0	0	0	0	0	0	0	0	0	0	0
34	o Cooley F	1S/4W-02L02S	3601226	0	0	0	0	0	0	0	0	0	0	0	0	0
35	o Cooley G	1S/4W-02N02S	3601227	0	0	0	0	0	0	0	0	0	0	0	0	0
36	Cooley H	1S/4W-11D02S	3601228	1,138	907	1,489	1,160	633	933	820	864	1,003	1,032	1,132	898	773
37	Cooley I	1S/4W-11D03S	3601229	3,242	3,221	3,680	2,264	2,239	2,505	1,891	2,291	2,332	1,886	2,716	2,197	2,321
38	o Cooley A	1S/4W-11D04S	3601232	-	-	-	-	-	-	-	-	-	-	-	-	-
39	o Cooley B	1S/4W-11D01S	3601432	-	-	-	-	-	-	-	-	-	-	-	-	-
40	Raub # 1	1S/4W-14P02S	3601218	0	0	0	0	0	0	0	0	0	0	0	0	0
41	Raub # 2	1S/4W-23C02S	3601219	222	3	96	0	37	250	169	64	99	285	254	342	411
42	Raub # 4	1S/4W-23C03S	3601238	1,649	1,775	2,201	1,425	1,957	1,096	1,005	1,029	1,628	1,326	1,602	1,228	412
43	Raub # 3	1S/4W-14P06S	3601239	221	43	236	460	89	340	321	205	280	342	273	343	339
44	Raub # 5	1S/4W-14N09S	3602484	3,359	3,747	3,351	4,223	3,327	3,182	3,093	3,030	2,538	1,783	1,471	2,401	2,438
45	o Byrne 1	1S/4W-22B02S	3601237	-	-	-	-	-	-	-	-	-	-	-	-	-
46	Warren # 3	1S/4W-22H03S	3601230	2	0	276	72	17	201	44	103	51	116	115	177	216
47	Warren # 2	1S/4W-22H01S	3601231	517	1,111	1,185	725	842	801	717	1,075	884	570	277	506	525
48	Warren # 1	1S/4W-22H04S	3601240	1,014	490	467	749	1,105	1,175	996	999	2,119	1,765	1,383	1,742	1,069
49	Warren # 4	1S/4W-22H02S	3601243	1,559	2,592	2,844	2,526	3,077	2,374	1,586	1,805	1,243	1,583	1,744	1,833	242
50	Hunt # 6 *	1S/4W-27A11S	3602771	568	224	866	661	454	642	496	394	472	233	144	323	413
51	o Hunt # 8 *	1S/4W-27A07S	3601241	-	-	-	-	-	-	-	-	-	-	-	-	-
52	o Hunt # 9 *	1S/4W-27A08S	3601242	-	-	-	-	-	-	-	-	-	-	-	-	-
53	Hunt # 10 *	1S/4W-27A09S	3602772	1,547	1,307	1,170	726	912	782	694	845	1,027	791	460	536	481
54	Hunt # 11 *	1S/4W-27A10S	3602773	850	537	782	477	434	634	608	326	961	636	536	440	430
55	Stewart # 21	1S/4W-27A13S	3601233	-	-	-	-	-	-	-	-	-	-	-	-	-
56	o Stewart # 19	1S/4W-27A19S	3601234	-	-	-	-	-	-	-	-	-	-	-	-	-
57	Stewart # 20	1S/4W-27H01S	3601431	1	1	1	3	1	1	1	3	1	1	1	1	3
58	Raub # 6	1S/4W-14N10S	3602778	4,239	4,162	4,655	2,638	3,482	3,968	2,258	2,397	2,516	2,131	2,250	1,974	390
59	Garner # 6	1S/4W-02P09S	3603254	0	0	0	0	0	0	0	0	2,088	3,082	3,476	3,428	4,014
59a	Raub # 8	1S/4W-14N10S	3603555	0	0	0	0	0	0	0	0	0	2,055	2,559	2,917	2,618
60	Sub Total	(Lines 31 - 60)		20,128	20,120	23,299	18,109	18,606	18,884	14,699	15,430	19,242	19,617	20,393	21,286	17,095
61																
62	Sub Total	(Lines 1 - 30)	sheet 1	5,553	4,911	8,518	7,887	6,922	7,606	6,430	5,512	6,891	5,166	5,174	4,438	6,221
63																
64	TOTAL PRODUCTION FROM BUNKER HILL BASIN			25,681	25,031	31,817	25,996	25,528	26,490	21,129	20,942	26,133	24,783	25,567	25,724	23,316
65																
66	ADDITIONAL DELIVERIES FROM OTHER COMPANIES															
67	MEEKS & DALEY	Station 59	3601887	2,317	2,567	2,492	2,660	2,274	2,251	2,505	2,079	1,597	1,888	1,597	2,141	2,322
68	MEEKS & DALEY	Warren #4 Lease	3602863						0	399	519	1,098	447	447	347	750
69	MEEKS & DALEY	Raub #6 Lease	3602864						0	139	791	302	950	378	639	94
70	NET WATER EXCHANGE WITH CITY OF SAN BERNARDINO								-769	0	0	0	0	198	0	0
71	Sub Total	(Lines 67 - 70)		2,317	2,567	2,492	2,660	2,274	1,482	3,043	3,389	2,997	3,285	2,620	3,127	3,166
72																
73	TOTAL WATER FOR DISTRIBUTION	(Line 64 + 71)		27,998	27,598	34,309	28,656	27,802	27,972	24,172	24,331	29,130	28,068	28,187	28,851	26,482

o Abandoned &/or File Closed.

* Figures shown for Hunt wells are for C of R use only, University of California reports its own usage.

** Gage 30-1 & Gage Stewart removed after covering of the Canal in 1975.

TABLE NO. 1

CITY OF RIVERSIDE WATER PRODUCTION
BUNKER HILL BASIN
DOMESTIC & IRRIGATION DIVISIONS INCLUDING FORMER RIVERSIDE WATER CO.
IN SAN BERNARDINO BASIN AREA

(Quantities in Acre Feet by Calendar Year)

Ln #	Local Designation	State Well #	Recordation #	2011	2012	2013	2014	2015	2016	2017	2018	2019	2020	2021	2022	2023	2024	2025
31	o Raub # 1	1S/4W-14P02S	3601218	-	-	-	-	-	-	-	-	-	-	-	-	-	-	-
32	Raub # 2	1S/4W-23C02S	3601219	0	0	-	-	-	-	-	-	-	-	-	-	-	-	-
33	o Cooley E	1S/4W-02P04S	3601220	-	-	-	-	-	-	-	-	-	-	-	-	-	-	-
34	o Cooley C	1S/4W-02P03S	3601224	-	-	-	-	-	-	-	-	-	-	-	-	-	-	-
35	o Cooley D	1S/4W-02P02S	3601225	-	-	-	-	-	-	-	-	-	-	-	-	-	-	-
36	o Cooley F	1S/4W-02L02S	3601226	-	-	-	-	-	-	-	-	-	-	-	-	-	-	-
37	o Cooley G	1S/4W-02N02S	3601227	-	-	-	-	-	-	-	-	-	-	-	-	-	-	-
38	Cooley H	1S/4W-11D02S	3601228	552	51	-	-	-	-	-	-	-	-	-	-	-	-	-
39	Cooley I	1S/4W-11D03S	3601229	1,289	1,329	-	-	-	-	-	-	-	-	-	-	-	-	-
40	Warren # 3	1S/4W-22H03S	3601230	0	0	-	-	-	-	-	-	-	-	-	-	-	-	-
41	Warren # 2	1S/4W-22H01S	3601231	0	0	-	-	-	-	-	-	-	-	-	-	-	-	-
42	o Cooley A	1S/4W-11D04S	3601232	-	-	-	-	-	-	-	-	-	-	-	-	-	-	-
43	o Stewart # 21	1S/4W-27A13S	3601233	-	-	-	-	-	-	-	-	-	-	-	-	-	-	-
44	o Stewart # 19	1S/4W-27A19S	3601234	-	-	-	-	-	-	-	-	-	-	-	-	-	-	-
45	o Byrne 1	1S/4W-22B02S	3601237	-	-	-	-	-	-	-	-	-	-	-	-	-	-	-
46	Raub # 4	1S/4W-23C03S	3601238	1,800	1,294	-	-	-	-	-	-	-	-	-	-	-	-	-
47	Raub # 3	1S/4W-14P06S	3601239	0	0	-	-	-	-	-	-	-	-	-	-	-	-	-
48	Warren # 1	1S/4W-22H04S	3601240	32	528	-	-	-	-	-	-	-	-	-	-	-	-	-
49	o Hunt # 8 *	1S/4W-27A07S	3601241	-	-	-	-	-	-	-	-	-	-	-	-	-	-	-
50	o Hunt # 9 *	1S/4W-27A08S	3601242	-	-	-	-	-	-	-	-	-	-	-	-	-	-	-
51	Warren # 4	1S/4W-22H02S	3601243	64	0	-	-	-	-	-	-	-	-	-	-	-	-	-
52	Stewart # 20	1S/4W-27H01S	3601431	0	0	-	-	-	-	-	-	-	-	-	-	-	-	-
53	o Cooley B	1S/4W-11D01S	3601432	-	-	-	-	-	-	-	-	-	-	-	-	-	-	-
54	Raub # 5	1S/4W-14N09S	3602484	3	123	-	-	-	-	-	-	-	-	-	-	-	-	-
55	Hunt # 6 *	1S/4W-27A11S	3602771	7	0	-	-	-	-	-	-	-	-	-	-	-	-	-
56	Hunt # 10 *	1S/4W-27A09S	3602772	0	0	-	-	-	-	-	-	-	-	-	-	-	-	-
57	Hunt # 11 *	1S/4W-27A10S	3602773	0	0	-	-	-	-	-	-	-	-	-	-	-	-	-
58	Raub # 6	1S/4W-14N10S	3602778	88	46	-	-	-	-	-	-	-	-	-	-	-	-	-
59	Garner # 7	1S/4W-02Q11S	3603948	2,209	2,946	-	-	-	-	-	-	-	-	-	-	-	-	-
59a	Garner # 6	1S/4W-02P09S	3603254	2,696	2,472	-	-	-	-	-	-	-	-	-	-	-	-	-
59b	Raub # 8	1S/4W-14N10S	3603555	336	992	-	-	-	-	-	-	-	-	-	-	-	-	-
59c	Cooley J	1S/4W-11D06S	3603775	2,399	1,859	-	-	-	-	-	-	-	-	-	-	-	-	-
59d	Raub #7	1S/4W-23C06S	3603929	921	260	-	-	-	-	-	-	-	-	-	-	-	-	-
60	Sub Total	(Lines 31 - 60)		12,396	11,900													
61																		
62	Sub Total	(Lines 1 - 30)	Sheet 1	4,301	4,484													
63																		
64	TOTAL PRODUCTION FROM BUNKER HILL BASIN			16,697	16,384													
65																		
66	ADDITIONAL DELIVERIES FROM OTHER COMPANIES																	
67	MEEKS & DALEY	Station 59	3601887	0	0													
68	MEEKS & DALEY	Warren #4 Lease	3602863	630	857													
69	MEEKS & DALEY	Raub #6 Lease	3602864	1,841	2,082													
69a	MEEKS & DALEY	Warren #1 Lease	3603904	0	0													
69b	MEEKS & DALEY	Raub 8 Lease	3603905	1,553	366													
69c	MEEKS & DALEY	Raub 5 Lease	3603906	1,154	1,341													
69c1	MEEKS & DALEY	Garner 6 Lease	3603939	0	0													
69c2	MEEKS & DALEY	Tippecanoe Lease	3603928	0	0													
69c3	MEEKS & DALEY	Garner 7 Lease	3603940	0	0													
69c4	MEEKS & DALEY	Raub 7 Lease	3603951	1,939	2,471													
69d	M&D Lease subtotal			7,117	7,117													
69e																		
69f	RIVERSIDE HIGHLANDS	Cooley H Lease	3603911	440	414													
69g	RIVERSIDE HIGHLANDS	Cooley I Lease	3603912	0	26													
69h	RIVERSIDE HIGHLANDS	Cooley J Lease	3603913	0	0													
69i	RIVERSIDE HIGHLANDS	Raub 6 Lease	3603907	0	0													
69j	RIVERSIDE HIGHLANDS	Raub 8 Lease	3603908	0	0													
69k	RH Lease subtotal			440	440													
69l																		
70	NET WATER EXCHANGE WITH CITY OF SAN BERNARDINO			0	0													
71	Sub Total	(Lines 67 - 70)		7,557	7,557													
72																		
73	TOTAL WATER FOR DISTRIBUTION	(line 64 + 71)		24,254	23,941													

o Abandoned &/or File Closed.
 * Figures shown for Hunt wells are for C of R use only, University of California reports its own usage.

TABLE NO. 2

CITY OF RIVERSIDE WATER PRODUCTION
COLTON BASIN & RIVERSIDE BASIN IN SAN BERNARDINO CO.
DOMESTIC & IRRIGATION DIVISIONS INCLUDING FORMER RIVERSIDE WATER CO.

(Quantities in Acre Feet by Calendar Year)

Ln #	Local Designation	State Well #	Recordation #	1971	1972	1973	1974	1975	1976	1977	1978	1979	1980	1981	1982
Colton Basin															
1	Johnson #1	1S/4W-21Q03S	3601480	851	954	1	526	1,162	479	241	0	1	0	23	15
2	o Johnson #2	1S/4W-21P01S	3601494	-	-	-	-	-	-	-	-	-	-	-	-
3	o Johnson #3	1S/4W-21Q01S	3601495	-	-	-	-	-	-	-	-	-	-	-	-
4	Johnson #4	1S/4W-21L04S	3603255	0	0	0	0	0	0	0	0	0	0	0	0
5	Johnson #5	1S/4W-21L		0	0	0	0	0	0	0	0	0	0	0	0
6	Vaughn #1	1S/4W-21L01S	3601481	1,193	956	0	378	816	67	0	456	3	0	31	22
7	Meek #1	1S/4W-28C01S	3601482	443	383	31	315	397	299	25	0	1	5	11	11
8	Mills	1S/4W-28D01S	3602208	209	228	69	167	170	8	29	8	0	0	12	9
9	Total Production - Colton			2,696	2,521	101	1,386	2,545	853	295	464	5	5	77	57
Riverside Basin- In San Bernardino County															
12	o Flume #1	1S/4W-29H02S	3601483	-	-	-	-	-	-	-	-	-	-	-	-
13	Flume #2	1S/4W-29H01S	3601484	855	1,856	1,778	547	530	2	401	7	15	1	6	2
14	Flume #3	1S/4W-29R01S	3601485	161	496	486	364	103	3	192	1	0	0	15	8
15	Flume #4 *	1S/4W-29Q03S	3601486	8	404	144	533	1,030	1,615	561	0	0	8	0	12
16	o Flume #5	1S/4W-29Q01S	3601487	-	-	-	-	-	-	-	-	-	-	-	-
17	Flume #6 *	1S/4W-29Q04S	3602486	0	0	0	144	408	832	45	0	0	2	0	2
18	Sub Total			1,024	2,756	2,408	1,588	2,071	2,452	1,199	8	15	11	21	24
19	Twin Buttes #6	1S/5W-25R02S	3600898												
20		1S/5W-25R04S	3600898-	406	173	0	1,539	807	426	69	0	0	0	0	0
21	Pelissier River	1S/5W-36Q	3301088	0	0	0	0	0	0	0	0	0	0	0	0
22	Pelissier Agua Mansa **	1S/5W-36L01S	3601236	157	55	0	3	12	2	7	7	19	25	23	25
23	o Pelissier La Loma	2S/5W-01G01S	3601235	-	-	-	-	-	-	-	-	-	-	-	-
24	Pelissier Main	2S/5W-01G02S	3601223	13	47	40	103	77	117	265	258	558	1,551	1,489	2,063
25	Pelissier Domestic	2S/5W-01J03S	3601221	4	5	5	5	5	7	7	6	10	15	14	14
26	Sub Total Lines 21-25 (Pelissier Ranch)			174	107	45	111	94	126	279	271	587	1,591	1,526	2,102
27	Prescriptive Rights Only														
28	Marcy C.E.														
29	o Putnam L.L.	2S/4W-06Q03S	3601271	-	-	-	-	-	-	-	-	-	-	-	-
30	o Williams	2S/5W-01Q01S	3601488	-	-	-	-	-	-	-	-	-	-	-	-
31	o Jurupa #1	2S/5W-02R	3601490	381	321	277	3	322	649	359	-	-	-	-	-
32	o Jurupa #3	2S/5W-02R03S	3601491	902	942	563	910	852	936	787	-	-	-	-	-
33	o Jurupa #4	2S/5W-02R02S	3601492	136	138	307	466	281	192	102	-	-	-	-	-
34	o Jurupa #5	2S/5W-02R01S	3601493	1,452	1,453	1,273	1,504	1,411	1,564	1,317	-	-	-	-	-
35	Jurupa #6	2S/5W-02Q07S	3602234	62	30	113	2	0	0	0	0	0	0	0	0
36	Jurupa #7	2S/5W-02Q08S	3602748	0	0	0	0	0	0	0	0	0	0	1,347	1,489
37	Mason	2S/5W-02Q	0000031	0	0	0	0	0	0	0	1,085	2,234	95	0	0
38	Van Buren #1	2S/4W-05E01S	3603117												
39	Van Buren #2	2S/4W-05E02S	3603118												
40	Sub Total Lines 28-39			2,933	2,884	2,533	2,885	2,866	3,341	2,565	1,085	2,234	104	1,347	1,489
41															
43	Total Production			4,131	5,747	4,986	4,584	5,031	5,919	4,043	1,364	2,836	1,706	2,894	3,615
44															
45	Total Production - Riverside North			4,537	5,920	4,986	6,123	5,838	6,345	4,112	1,364	2,836	1,706	2,894	3,615

TABLE NO. 2

CITY OF RIVERSIDE WATER PRODUCTION
COLTON BASIN & RIVERSIDE BASIN IN SAN BERNARDINO CO.
DOMESTIC & IRRIGATION DIVISIONS INCLUDING FORMER RIVERSIDE WATER CO.

(Quantities in Acre Feet by Calendar Year)

Ln #	Local Designation	State Well #	Recordation #	1983	1984	1985	1986	1987	1988	1989	1990	1991	1992	1993	1994	1995
Colton Basin																
1	o Johnson #1	1S/4W-21Q03S	3601480	-	-	-	-	-	-	-	-	-	-	-	-	-
2	o Johnson #2	1S/4W-21P01S	3601494	-	-	-	-	-	-	-	-	-	-	-	-	-
3	o Johnson #3	1S/4W-21Q01S	3601495	-	-	-	-	-	-	-	-	-	-	-	-	-
4	Johnson #4	1S/4W-21L04S	3603255	0	0	0	0	0	0	0	0	0	0	0	0	0
5	Johnson #5	1S/4W-21L		0	0	0	0	0	0	0	0	0	0	0	0	0
6	Vaughn #1	1S/4W-21L01S	3601481	0	0	695	0	0	0	0	0	0	0	0	0	0
7	Meek #1	1S/4W-28C01S	3601482	0	0	0	0	0	0	0	0	0	0	0	0	0
8	Mills	1S/4W-28D01S	3602208	0	0	0	0	0	0	519	131	428	307	311	466	171
9	Total Production - Colton			0	0	695	0	0	0	519	131	428	307	311	466	171
Riverside Basin- In San Bernardino County																
12	o Flume #1	1S/4W-29H02S	3601483	-	-	-	-	-	-	-	-	-	-	-	-	-
13	Flume #2	1S/4W-29H01S	3601484	18	6	4	6	11	29	11	6	507	917	347	50	572
14	Flume #3	1S/4W-29R01S	3601485	2	0	29	50	21	4	18	7	1,692	344	548	131	628
15	Flume #4 *	1S/4W-29Q03S	3601486	25	0	28	127	0	0	15	0	0	0	0	0	0
16	o Flume #5	1S/4W-29Q01S	3601487	-	-	-	-	-	-	-	-	-	-	-	-	-
17	Flume #6 *	1S/4W-29Q04S	3602486	12	3	18	10	17	35	20	8	1,174	845	653	234	997
18	Sub Total			57	9	79	193	49	68	64	21	3,373	2,106	1,548	415	2,197
19	Twin Buttes #6	1S/5W-25R04S	3600898-	0	0	0	0	12	1,199	407	355	0	0	0	0	0
21	Pelissier River	1S/5W-36Q	3301088	0	0	0	0	0	0	0	0	0	0	0	0	0
22	Pelissier Agua Mansa	1S/5W-36L01S	3601236	26	58	29	93	65	21	27	28	28	90	69	72	0
23	o Pelissier La Loma	2S/5W-01G01S	3601235	-	-	-	-	-	-	-	-	-	-	-	-	-
24	Pelissier Main	2S/5W-01G02S	3601223	1,866	387	652	0	0	16	12	966	959	240	0	0	0
25	Pelissier Domestic	2S/5W-01J03S	3601221	41	3	33	24	22	21	20	17	18	4	0	0	0
26	Sub Total Lines 21-25 (Pelissier Ranch)			1,933	448	714	117	87	58	59	1,011	1,005	334	69	72	0
28	Marcy C.E.	Prescriptive Rights Only														
29	o Putnam L.L.	2S/4W-06Q03S	3601271	-	-	-	-	-	-	-	-	-	-	-	-	-
30	o Williams	2S/5W-01Q01S	3601488	-	-	-	-	-	-	-	-	-	-	-	-	-
31	o Jurupa #1	2S/5W-02R	3601490	-	-	-	-	-	-	-	-	-	-	-	-	-
32	o Jurupa #3	2S/5W-02R03S	3601491	-	-	-	-	-	-	-	-	-	-	-	-	-
33	o Jurupa #4	2S/5W-02R02S	3601492	-	-	-	-	-	-	-	-	-	-	-	-	-
34	o Jurupa #5	2S/5W-02R01S	3601493	-	-	-	-	-	-	-	-	-	-	-	-	-
35	Jurupa #6	2S/5W-02Q07S	3602234	0	0	0	0	0	0	0	0	0	0	0	0	0
36	Jurupa #7	2S/5W-02Q08S	3602748	591	2,434	2,400	2,032	1,614	1,990	2,088	1,822	1,511	1,398	947	1,133	1,225
37	o Mason	2S/5W-02Q		-	-	-	-	-	-	-	-	-	-	-	-	-
38	Van Buren #1	2S/4W-05E01S	3603117							3,592	3,872	3,652	3,132	3,109	3,311	3,655
39	Van Buren #2	2S/4W-05E02S	3603118							3,984	3,902	3,662	3,373	3,627	3,272	3,678
40	Sub Total Lines 28-39			591	2,434	2,400	2,032	1,614	1,990	9,664	9,596	8,825	7,903	7,683	7,716	8,558
43	Total Production			2,581	2,891	3,193	2,342	1,750	2,116	9,787	10,628	13,203	10,343	9,300	8,203	10,755
44																
45	Total Production - Riverside North			2,581	2,891	3,193	2,342	1,762	3,315	10,194	10,983	13,203	10,343	9,300	8,203	10,755

o Abandoned &/or File Closed.

* A portion of the flows from Flume 4 & 6 can be leased to the La Sierra Water Co., portion shown is Riverside's production only.

TABLE NO. 2

CITY OF RIVERSIDE WATER PRODUCTION
 COLTON BASIN & RIVERSIDE BASIN IN SAN BERNARDINO CO.
 DOMESTIC & IRRIGATION DIVISIONS INCLUDING FORMER RIVERSIDE WATER CO.

(Quantities in Acre Feet by Calendar Year)

Ln #	Local Designation	State Well #	Recordation #	1996	1997	1998	1999	2000	2001	2002	2003	2004	2005	2006	2007	2008	2009	2010	
Colton Basin																			
1	o Johnson #1	1S/4W-21Q03S	3601480	-	-	-	-	-	-	-	-	-	-	-	-	-	-	-	
2	o Johnson #2	1S/4W-21P01S	3601494	-	-	-	-	-	-	-	-	-	-	-	-	-	-	-	
3	o Johnson #3	1S/4W-21Q01S	3601495	-	-	-	-	-	-	-	-	-	-	-	-	-	-	-	
4	Johnson #4	1S/4W-21L04S	3603255	0	0	0	0	0	0	0	0	0	0	0	0	0	0	0	
5	Johnson #5	1S/4W-21L		0	0	0	0	0	0	0	0	0	0	0	0	0	0	0	
6	Vaughn #1	1S/4W-21L01S	3601481	0	0	0	0	0	0	0	0	0	0	0	0	0	0	0	
7	Meek #1	1S/4W-28C01S	3601482	0	0	0	0	0	0	0	0	0	0	0	0	0	0	0	
8	Mills	1S/4W-28D01S	3602208	208	633	142	7	128	0	0	171	0	0	122	0	1	0	0	
9	Total Production - Colton			208	633	142	7	128	0	0	171	0	0	122	0	1	0	0	
Riverside Basin in San Bernardino County																			
12	o Flume #1	1S/4W-29H02S	3601483	-	-	-	-	-	-	-	-	-	-	-	-	-	-	-	
13	Flume #2	1S/4W-29H01S	3601484	723	863	300	813	770	525	847	15	0	667	1,650	35	954	2,749	1,577	
14	Flume #3	1S/4W-29R01S	3601485	10	0	0	0	0	0	0	0	0	686	1,447	0	974	2,477	2,671	
15	Flume #4	1S/4W-29Q03S	3601486	0	0	0	0	0	0	0	0	0	429	674	0	934	2,244	2,311	
16	o Flume #5	1S/4W-29Q01S	3601487	-	-	-	-	-	-	-	-	-	-	-	-	-	-	-	
17	Flume #6	1S/4W-29Q04S	3602486	1,173	1,408	590	1,265	1,901	698	984	849	0	757	874	0	959	735	30	
18	Sub Total			1,906	2,271	890	2,078	2,671	1,223	1,831	864	0	2,539	4,645	35	3,821	8,205	6,589	
19	Twin Buttes #6 **	1S/5W-25R04S	3600898-	0	0	0	1	1	1	1	1	1	0	0	0	0	0	0	
21	Pelissier River	1S/5W-36Q	3301088	0	0	0	0	0	0	0	0	0	0	0	0	0	0	0	
22	Pelissier Agua Mansa	1S/5W-36L01S	3601236	0	0	0	0	0	0	0	0	0	0	0	0	0	0	0	
23	o Pelissier La Loma	2S/5W-01G01S	3601235	-	-	-	-	-	-	-	-	-	-	-	-	-	-	-	
24	Pelissier Main	2S/5W-01G02S	3601223	0	0	0	0	0	0	0	0	0	0	0	0	0	0	0	
25	Pelissier Domestic	2S/5W-01J03S	3601221	0	0	0	0	0	0	0	0	0	0	0	0	0	0	0	
26	Sub Total Lines 21-25 (Pelisser Ranch)			0	0	0	0	0	0	0	0	0	0	0	0	0	0	0	
28	Marcy C.E.	Prescriptive Rights Only																	
29	o Putnam L.L.	2S/4W-06Q03S	3601271	-	-	-	-	-	-	-	-	-	-	-	-	-	-	-	
30	o Williams	2S/5W-01Q01S	3601488	-	-	-	-	-	-	-	-	-	-	-	-	-	-	-	
31	o Jurupa #1	2S/5W-02R	3601490	-	-	-	-	-	-	-	-	-	-	-	-	-	-	-	
32	o Jurupa #3	2S/5W-02R03S	3601491	-	-	-	-	-	-	-	-	-	-	-	-	-	-	-	
33	o Jurupa #4	2S/5W-02R02S	3601492	-	-	-	-	-	-	-	-	-	-	-	-	-	-	-	
34	o Jurupa #5	2S/5W-02R01S	3601493	-	-	-	-	-	-	-	-	-	-	-	-	-	-	-	
35	Jurupa #6	2S/5W-02Q07S	3602234	0	0	0	0	0	0	0	0	0	0	0	0	0	0	0	
36	Jurupa #7	2S/5W-02Q08S	3602748	1,087	1,067	1,034	1,116	997	974	1,161	1,500	1,036	1,432	1,208	1,414	987	1,122	978	
37	o Mason	2S/5W-02Q		-	-	-	-	-	-	-	-	-	-	-	-	-	-	-	
38	Van Buren #1	2S/4W-05E01S	3603117	3,476	2,750	2,925	2,967	2,563	2,609	2,366	2,009	1,942	2,102	2,180	1,997	1,915	2,192	1,898	
39	Van Buren #2	2S/4W-05E02S	3603118	2,595	2,081	1,916	2,721	2,397	2,481	2,455	2,016	2,144	1,756	2,243	2,242	2,079	2,095	1,580	
40	Sub Total Lines 28-39			7,158	5,898	5,875	6,804	5,957	6,064	5,982	5,525	5,122	5,290	5,631	5,653	4,981	5,409	4,456	
43	Total Production - Riverside North			9,064	8,169	6,765	8,883	8,629	7,288	7,814	6,390	5,123	7,829	10,276	5,688	8,802	13,614	11,045	
44	o Abandoned &/or File Closed.																		
45	** Overlying land use - Tiger Rescue																		

TABLE NO. 2

CITY OF RIVERSIDE WATER PRODUCTION
COLTON BASIN & RIVERSIDE BASIN IN SAN BERNARDINO CO.
DOMESTIC & IRRIGATION DIVISIONS INCLUDING FORMER RIVERSIDE WATER CO.

(Quantities in Acre Feet by Calendar Year)

Ln #	Local Designation	State Well #	Recordation #	2011	2012	2013	2014	2015	2016	2017	2018	2019	2020	2021	2022	2023	2024	2025	
<u>Colton Basin</u>																			
1	o Johnson #1	1S/4W-21Q03S	3601480	-	-	-	-	-	-	-	-	-	-	-	-	-	-	-	
2	o Johnson #2	1S/4W-21P01S	3601494	-	-	-	-	-	-	-	-	-	-	-	-	-	-	-	
3	o Johnson #3	1S/4W-21Q01S	3601495	-	-	-	-	-	-	-	-	-	-	-	-	-	-	-	
4	Johnson #4	1S/4W-21L04S	3603255	0	0														
5	Johnson #5	1S/4W-21L		0	0														
6	Vaughn #1	1S/4W-21L01S	3601481	0	0														
7	Meek #1	1S/4W-28C01S	3601482	0	0														
8	Mills	1S/4W-28D01S	3602208	0	0														
9	Total Production - Colton			0	0														
10																			
11	<u>Riverside Basin in San Bernardino County</u>																		
12	o Flume #1	1S/4W-29H02S	3601483	-	-	-	-	-	-	-	-	-	-	-	-	-	-	-	
13	Flume #2	1S/4W-29H01S	3601484	1,667	1,675														
14	Flume #3	1S/4W-29R01S	3601485	3,125	2,872														
15	Flume #4	1S/4W-29Q03S	3601486	2,697	2,236														
16	o Flume #5	1S/4W-29Q01S	3601487	-	-	-	-	-	-	-	-	-	-	-	-	-	-	-	
17	Flume #6	1S/4W-29Q04S	3602486	319	393														
17a	Flume #7	1S/4W-323F05S	3603961		1,948														
18	Sub Total *			7,808	9,124														
19	Twin Buttes #6 **	1S/5W-25R04S	3600898-	-	-	-	-	-	-	-	-	-	-	-	-	-	-	-	
20																			
21	Pelissier River	1S/5W-36Q	3301088	0	0														
22	Pelissier Agua Mansa	1S/5W-36L01S	3601236	0	0														
23	o Pelissier La Loma	2S/5W-01G01S	3601235	-	-	-	-	-	-	-	-	-	-	-	-	-	-	-	
24	Pelissier Main	2S/5W-01G02S	3601223	0	0														
25	Pelissier Domestic	2S/5W-01J03S	3601221	0	0														
26	Sub Total Lines 21-25 (Pelisser Ranch)			0	0														
27																			
28	Marcy C.E. Prescriptive Rights Only																		
29	o Putnam L.L.	2S/4W-06Q03S	3601271	-	-	-	-	-	-	-	-	-	-	-	-	-	-	-	
30	o Williams	2S/5W-01Q01S	3601488	-	-	-	-	-	-	-	-	-	-	-	-	-	-	-	
31	o Jurupa #1	2S/5W-02R	3601490	-	-	-	-	-	-	-	-	-	-	-	-	-	-	-	
32	o Jurupa #3	2S/5W-02R03S	3601491	-	-	-	-	-	-	-	-	-	-	-	-	-	-	-	
33	o Jurupa #4	2S/5W-02R02S	3601492	-	-	-	-	-	-	-	-	-	-	-	-	-	-	-	
34	o Jurupa #5	2S/5W-02R01S	3601493	-	-	-	-	-	-	-	-	-	-	-	-	-	-	-	
35	Jurupa #6	2S/5W-02Q07S	3602234	0	0														
36	Jurupa #7	2S/5W-02Q08S	3602748	1,071	1,092														
37	o Mason	2S/5W-02Q		-	-	-	-	-	-	-	-	-	-	-	-	-	-	-	
38	Van Buren #1	2S/4W-05E01S	3603117	1,689	1,967														
39	Van Buren #2	2S/4W-05E02S	3603118	1,475	1,693														
40	Sub Total Lines 28-39			4,235	4,752														
41																			
43	Total Production - Riverside North			12,043	13,876														
44	o Abandoned &/or File Closed.																		
45	** Overlying land use																		

TABLE NO. 2

CITY OF RIVERSIDE WATER PRODUCTION
RIVERSIDE BASIN IN RIVERSIDE CO.
DOMESTIC & IRRIGATION DIVISIONS INCLUDING FORMER RIVERSIDE WATER CO.

(Quantities in Acre Feet by Calendar Year)

Ln #	Local Designation	State Well #	Recordation #	1971	1972	1973	1974	1975	1976	1977	1978	1979	1980	1981	1982
Riverside Basin in Riverside County															
46	Electric Street	2S/4W-07L01S	3301287	329	898	1,313	1,612	1,344	225	1,119	162	424	2,435	2,541	131
47	o Palmyrita #1	2S/4W-07N01S	3301286	-	-	-	-	-	-	-	-	-	-	-	-
48	Palmyrita #2	2S/4W-07N03S	3301286-	415	783	562	1,829	1,275	345	605	840	1,564	2,056	320	0
49	o Cunningham #1	2S/5W-13Q01S	3301285	-	-	-	-	-	-	-	-	-	-	-	-
50	Cunningham #2	2S/5W-13Q02S	3301285-	163	129	28	542	113	2,405	2,588	1,838	833	2,809	3,633	426
51															
52	First Street	2S/5W-24D01S	3301284	480	673	406	692	670	748	920	545	708	1,179	1,016	866
53	Fill	2S/5W-23R01S	3301288	625	1,262	1,039	1,105	766	469	207	420	1,276	478	674	230
54	Eleventh	2S/5W-23Q01S	3301289	1,393	1,589	1,228	1,679	211	477	97	198	1,380	565	793	132
55	Highgrove #1	2S/4W-08E01S	3301358	0	0	0	0	0	0	0	0	0	0	0	0
56	o Highgrove #2	2S/4W-08D03S	3301359	-	-	-	-	-	-	-	-	-	-	-	-
57	Highgrove #3	2S/4W-08D04S	3301359-	0	0	0	0	0	0	0	0	0	0	0	0
58	o Lemona	2S/4W-19J01S	3300686	-	-	-	-	-	-	-	-	-	-	-	-
59	Garner (T&G)	2S/5W-12B01S	3301075	300	275	253	251	220	248	257	177	265	328	243	198
60	o Russell	2S/5W-12A01S	3301084	-	-	-	-	-	-	-	-	-	-	-	-
61	Twin Springs	2S/5W-12K02S	3301073	3,119	3,736	2,841	3,111	2,526	3,504	2,435	1,822	1,978	2,434	2,868	2,674
62	Russell B	2S/5W-12A03S	3302531	727	2,010	1,694	1,972	1,561	2,323	1,359	1,678	1,822	1,966	1,930	1,364
62a	Russell C	2S/5W-13B07S	3302890												
63	Moore Griffith	2S/5W-12P01S	3301076	642	891	801	1,476	1,606	1,363	1,395	718	1,157	1,217	1,754	681
64	Mulberry	2S/5W-23J01S	3301074	363	406	125	773	471	557	5	0	24	0	94	0
65	Garner B	2S/5W-12B04S	3301959	1,049	1,548	1,350	992	581	1,528	1,552	1,875	1,033	1,156	1,332	1,411
66	Garner C	2S/5W-12C03S	3302472												
67	Garner D	2S/5W-12B06S	3302618												
68															
69	Sub Total Lines 46-69			9,605	14,200	11,640	16,034	11,344	14,192	12,539	10,273	12,464	16,623	17,198	8,113
70															
71	o Clearwater *	2S/5W-25F01S	3300417	-	-	-	-	-	-	-	-	-	-	-	-
72															
73	Brunton	2S/5W-12P02S	3301077	357	361	281	244	326	289	282	270	199	313	119	87
74	Fairmount Park #1	2S/5W-14G02S	3301082	691	471	868	864	0	0	440	692	7	1,503	169	298
75	Fairmount Park #2	2S/5W-14E01S	3301851	687	2,381	2,441	2,065	525	873	117	0	34	0	112	77
76	Mori No. 2	2S/5W-14G03S	3301635	1,442	1,537	1,161	1,517	287	122	134	452	596	307	2	472
77	o Springbrook Diversion	2S/5W-14K	3301086	-	-	-	-	-	-	-	-	-	-	-	-
78	o Sanitary Fill	2S/5W-28A01S	3301078	-	-	-	-	-	-	-	-	-	-	-	-
79	o Sanitary Fill, Davis	2S/5W-28C01S	3301079	-	-	-	-	-	-	-	-	-	-	-	-
80	o Jensen Slough **	2S/5W-29G	3301087	1,089	871	421	**	**	**	**	**	**	**	**	**
81	Orange Acres Mutual	3S/5W-03F01S	3301814	57	90	63	67	69	6	0	0	0	0	0	0
82	Lincoln Heights Wtr	3S/5W-09E01S	3301940	170	208	274	201	298	148	72	0	0	0	0	0
83	Freeway	2S/5W-23Q03S	3301915	378	455	362	549	503	435	408	573	35	9	71	306
84															
85	Sub Total Lines 73-84			4,871	6,374	5,871	5,507	2,008	1,873	1,453	1,987	871	2,132	473	1,240
86	Total Lines 69+71+85			14,476	20,574	17,511	21,541	13,352	16,065	13,992	12,260	13,335	18,755	17,671	9,353
87															
88	o Abandoned &/or File Closed.														
89	* Now owned by Victoria County Club.														
90	** Jensen Slough sold to Riverside County Parks Dept in 1972, Water rights Quit-Deeded back to the City in 1975.														
	Freeway Well added to City of Riverside during 2011 Verification														

TABLE NO. 2

CITY OF RIVERSIDE WATER PRODUCTION
RIVERSIDE BASIN IN RIVERSIDE CO.
DOMESTIC & IRRIGATION DIVISIONS INCLUDING FORMER RIVERSIDE WATER CO.

(Quantities in Acre Feet by Calendar Year)

Ln #	Local Designation	State Well #	Recordation #	1983	1984	1985	1986	1987	1988	1989	1990	1991	1992	1993	1994	1995
Riverside Basin in Riverside County																
46	Electric Street	2S/4W-07L01S	3301287	614	2,742	2,216	2,673	3,251	2,983	4,072	3,913	3,302	3,151	4,035	3,304	2,437
47	o Palmyrita #1	2S/4W-07N01S	3301286	-	-	-	-	-	-	-	-	-	-	-	-	-
48	Palmyrita #2	2S/4W-07N03S	3301286-	0	0	16	0	3	0	0	90	415	0	0	0	0
49	o Cunningham #1	2S/5W-13Q01S	3301285	-	-	-	-	-	-	-	-	-	-	-	-	-
50	Cunningham #2	2S/5W-13Q02S	3301285-	1,166	341	0	0	0	0	0	0	0	0	0	0	0
52	First Street	2S/5W-24D01S	3301284	769	1,083	22	35	8	438	781	491	609	1,385	1,433	1,055	1,251
53	Fill	2S/5W-23R01S	3301288	1,795	808	119	8	12	335	393	215	1,425	1,624	481	2,069	1,842
54	Eleventh	2S/5W-23Q01S	3301289	956	396	63	0	0	0	57	419	479	83	825	1,102	894
55	Highgrove #1	2S/4W-08E01S	3301358	0	0	0	0	0	0	0	0	0	0	0	0	0
56	o Highgrove #2	2S/4W-08D03S	3301359	-	-	-	-	-	-	-	-	-	-	-	-	-
57	Highgrove #3	2S/4W-08D04S	3301359-	-	0	0	0	0	0	0	0	0	0	0	0	0
58	o Lemona	2S/4W-19J01S	3300686	-	-	-	-	-	-	-	-	-	-	-	-	-
59	Garner (T&G)	2S/5W-12B01S	3301075	158	220	168	6	11	15	9	10	8	8	8	7	12
60	o Russell	2S/5W-12A01S	3301084	-	-	-	-	-	-	-	-	-	-	-	-	-
61	Twin Springs	2S/5W-12K02S	3301073	1,865	2,951	1,676	2,184	1,900	960	1,648	3	0	0	0	0	0
62	Russell B	2S/5W-12A03S	3302531	913	1,615	1,061	1,653	1,467	1,277	2,356	2,631	1,736	1,685	1,615	1,211	786
62a	Russell C	2S/5W-13B07S	3302890	0	0	0	0	0	0	0	0	0	0	0	0	0
63	Moore Griffith	2S/5W-12P01S	3301076	763	1,069	221	855	61	28	0	1	0	0	0	1	0
64	Mulberry	2S/5W-23J01S	3301074	1	1	0	0	0	0	0	0	1	0	0	0	0
65	Garner B	2S/5W-12B04S	3301959	699	1,411	810	1,004	1,508	1,387	3,104	2,698	2,579	784	1,755	1,851	120
66	Garner C	2S/5W-12C03S	3302472	0	0	0	0	1,769	2,495	3,782	3,706	3,025	2,854	2,538	1,870	1,345
67	Garner D	2S/5W-12B06S	3302618	0	0	0	0	0	0	0	0	1,090	2,316	2,099	1,373	1,127
69	Sub Total Lines 46-69			9,699	12,637	6,372	8,418	9,990	9,918	16,202	14,177	14,669	13,890	14,789	13,843	9,814
71	o Clearwater *	2S/5W-25F01S	3300417	-	-	-	-	-	-	-	-	-	-	-	-	-
73	Brunton	2S/5W-12P02S	3301077	265	394	0	381	137	179	160	158	0	0	0	0	0
74	Fairmount Park #1	2S/5W-14G02S	3301082	461	207	415	33	165	135	141	139	141	139	28	299	533
75	Fairmount Park #2	2S/5W-14E01S	3301851	434	298	39	49	30	39	36	38	37	41	150	1,417	1,132
76	Mori No. 2	2S/5W-14G03S	3301635	540	571	403	77	216	155	161	160	158	156	146	38	925
77	o Springbrook Diversion	2S/5W-14K	3301086	-	-	-	-	-	-	-	-	-	-	-	-	-
78	o Sanitary Fill	2S/5W-28A01S	3301078	-	-	-	-	-	-	-	-	-	-	-	-	-
79	o Sanitary Fill, Davis	2S/5W-28C01S	3301079	-	-	-	-	-	-	-	-	-	-	-	-	-
80	o Jensen Slough **	2S/5W-29G	3301087	**	**	**	**	**	**	**	**	**	**	**	**	**
81	o Orange Acres Mutual	3S/5W-03F01S	3301814	-	-	-	-	-	-	-	-	-	-	-	-	-
82	o Lincoln Heights Wtr	3S/5W-09E01S	3301940	-	-	-	-	-	-	-	-	-	-	-	-	-
83	Freeway	2S/5W-23Q03S	3301915	83	463	33	856	687	564	0	0	0	0	0	0	0
85	Sub Total Lines 73-84			1,783	1,933	890	1,396	1,235	1,072	498	495	336	336	324	1,754	2,590
86	Total Lines 69+71+85			11,482	14,570	7,262	9,814	11,225	10,990	16,700	14,672	15,005	14,226	15,113	15,597	12,404

o Abandoned &/or File Closed.

* Now owned by Victoria County Club.

** Jensen Slough sold to Riverside County Parks Dept in 1972, Water rights Quit-Deeded back to the City in 1975.

Freeway Well added to City of Riverside during 2011 Verification

TABLE NO. 2

CITY OF RIVERSIDE WATER PRODUCTION
RIVERSIDE BASIN IN RIVERSIDE CO.
DOMESTIC & IRRIGATION DIVISIONS INCLUDING FORMER RIVERSIDE WATER CO.

(Quantities in Acre Feet by Calendar Year)

Ln #	Local Designation	State Well #	Recordation #	2011	2012	2013	2014	2015	2016	2017	2018	2019	2020	2021	2022	2023	2024	2025
Riverside Basin in Riverside County																		
46	Electric Street	2S/4W-07L01S	3301287	3,067	1,324													
47	o Palmyrita #1	2S/4W-07N01S	3301286	-	-	-	-	-	-	-	-	-	-	-	-	-	-	-
48	Palmyrita #2	2S/4W-07N03S	3301286-	1,948	2,791													
49	o Cunningham #1	2S/5W-13Q01S	3301285	-	-	-	-	-	-	-	-	-	-	-	-	-	-	-
50	Cunningham #2	2S/5W-13Q02S	3301285-	0	0													
51																		
52	First Street	2S/5W-24D01S	3301284	1,082	1,611													
53	Fill	2S/5W-23R01S	3301288	1,371	1,521													
54	Eleventh	2S/5W-23Q01S	3301289	0	0													
55	Highgrove #1	2S/4W-08E01S	3301358	0	0													
56	o Highgrove #2	2S/4W-08D03S	3301359	-	-	-	-	-	-	-	-	-	-	-	-	-	-	-
57	Highgrove #3	2S/4W-08D04S	3301359-	0	0													
58	o Lemona	2S/4W-19J01S	3300686	-	-	-	-	-	-	-	-	-	-	-	-	-	-	-
59	Garner (T&G)	2S/5W-12B01S	3301075	3	4													
60	o Russell	2S/5W-12A01S	3301084	-	-	-	-	-	-	-	-	-	-	-	-	-	-	-
61	Twin Springs	2S/5W-12K02S	3301073	2,625	2,607													
62	Russell B	2S/5W-12A03S	3302531	0	0													
62a	Russell C	2S/5W-13B07S	3302890	0	0													
63	Moore Griffith	2S/5W-12P01S	3301076	1,093	1,629													
64	Mulberry	2S/5W-23J01S	3301074	1,320	776													
65	Garner B	2S/5W-12B04S	3301959	1,714	1,348													
66	Garner C	2S/5W-12C03S	3302472	2,209	1,572													
67	Garner D	2S/5W-12B06S	3302618	1,741	792													
68																		
69	Sub Total Lines 46-69			18,173	15,975													
70																		
71	o Clearwater *	2S/5W-25F01S	3300417	-	-	-	-	-	-	-	-	-	-	-	-	-	-	-
72																		
73	Brunton	2S/5W-12P02S	3301077	0	0													
74	Fairmount Park #1	2S/5W-14G02S	3301082	153	223													
75	Fairmount Park #2	2S/5W-14E01S	3301851	48	49													
76	Mori No. 2	2S/5W-14G03S	3301635	0	0													
77	o Springbrook Diversion	2S/5W-14K	3301086	-	-	-	-	-	-	-	-	-	-	-	-	-	-	-
78	o Sanitary Fill	2S/5W-28A01S	3301078	-	-	-	-	-	-	-	-	-	-	-	-	-	-	-
79	o Sanitary Fill, Davis	2S/5W-28C01S	3301079	-	-	-	-	-	-	-	-	-	-	-	-	-	-	-
80	o Jensen Slough **	2S/5W-29G	3301087	-	-	-	-	-	-	-	-	-	-	-	-	-	-	-
81	Orange Acres Mutual	3S/5W-03F01S	3301814	0	0													
82	Lincoln Heights Wtr	3S/5W-09E01S	3301940	0	0													
83	o Freeway	2S/5W-23Q03S	3301915	0	-	-	-	-	-	-	-	-	-	-	-	-	-	-
84																		
85	Sub Total Lines 73-84			201	272													
86	Total Lines 69+71+85			18,374	16,247													
87																		
88	Blowoff from Garner B and Palmyrita Treatment Plants			18	0													
89																		
90	Net Riverside South Basin Production Line 86 - 88			18,356	16,247													

o Abandoned &/or File Closed.

* Now owned by Victoria County Club.

** Jensen Slough sold to Riverside County Parks Dept in 1972, Water rights Quit-Deeded back to the City in 1975.

TABLE NO. 3

CITY OF RIVERSIDE
DOMESTIC AND IRRIGATION DIVISIONS
DELIVERIES MADE FROM WATER PRODUCED FROM THE BUNKER HILL,
COLTON AND RIVERSIDE GROUNDWATER BASINS SITUATED IN SAN BERNARDINO CO.

(Identification of Deliveries and Amounts Delivered In Acre Feet)

Calendar Year	Riverside Highland Water Co.	Salazar Water Co.	Trujillo Water Co.	Jurupa Ditch Co.	S.C.E. CO. Highgrove Power Plant	Pellissier Ranch	Williams Ranch	Net City of San Bernardino	Overlying Land Use	Total of all Deliveries
(1)	(2)	(3)	(4)	(5)	(6)	(7)	(8)	(9)	(10)	
1971	0	-	300	2,933	-	174	-	0		3,407
1972	0	-	175	2,884	-	107	-	0		3,166
1973	0	-	77	2,533	-	45	-	0		2,655
1974	279	-	73	2,885	-	111	-	0		3,348
1975	0	-	72	2,866	-	94	-	0		3,032
1976	0	-	80	3,341	-	126	-	0		3,547
1977	0	-	76	2,565	-	279	-	0		2,920
1978	0	-	174	1,085	-	271	-	0		1,530
1979	0	-	254	2,234	-	587	-	0		3,075
1980	0	-	328	104	-	1,591	-	0		2,023
1981	0	-	243	1,347	-	1,526	-	0		3,116
1982	0	-	185	1,489	-	2,102	-	0	146	3,922 *
1983	0	-	158	591	-	1,933	-	0	144	2,826 *

(1) From City of Riverside Records.
 (2) From City of Riverside Records.
 (3) From City of Riverside Records.
 (4) From Table No. 2, Sheet 1, Line 28
 (5) From City of Riverside Records.

(6) From Table No. 2, Sheet 1, Lines 20
 (7) From City of Riverside Records.
 (8) From City of Riverside Records.
 (9) Golf Course irrigation, Thorn 10 and 11.
 (10) Total of Column (1) through Column (9).

FOR YEARS PRECEEDING 1971: Refer to Volume 5, August 1976, Page I-21.

* Corrected during 1984 verification

- Column 1 Riverside Highlands delivery made from water product in Bunker Hill Basin. Water is commingled with production from other basins by RH and delivered by this company. See Riverside Highland tabulation for basin allocation of water production
- Column 2 Salazar Water Company delivery made in San Bernardino County from the canal of the Riverside Water Company, which contains commingled water produced from Bunker Hill, Colton, and Riverside Basins, all within San Bernardino County. Delivery is made directly to the West Riverside Canal and transported by this canal directly to Riverside County southerly of the County Line.
- Column 3 Trujillo Water Company. For the period 1947 through a portion of 1952, deliveries were made to the Trujillo Water Company at a point in San Bernardino County from the Canal of the Riverside Water Company, which contained a comingled water supply produced from the Bunker Hill, Colton and Riverside Groundwater Basins, all within San Bernardino County. For this period a portion of the 1952 through 1965, deliveries to the Trujillo Water Company were made from the Williams Well, producing water from that portion of the Riverside Ground Water Basin lying within San Bernardino County. The service area of the Trujillo Water company lies astride the Riverside-San Bernardino County Line, and during both of the periods described above, water was delivered both in San Bernardino County and in Riverside County to shareholders entitled to received this water by ownership of Trujillo Water Company stock. In addition, deliveries were also made from the Williams Well for overlying use on the Williams Ranch, situated within San Bernardino County. Tabulations of this proecution and the inter-county deliveries are shown in detail on Tables No. 4, 5, 6, and 7.
- Column 4 Deliveries to the Jurupa Ditch Company are made directly from the production from the Jurupa Wells, situated within the San Bernardino County in the Riverside Groundwater Basin and exported across the County Line to Riverside County. Deliveries for overlying use in San Bernardino County are also made from these wells for use on the Jurupa ranch in san Bernardino County. A tabulation of overlying use from the Jurupa Wells within San Bernardino County and exported to Riverside County are shown in Table No. 8. No other breakdown is required.
- Column 5 Water delivered to the Southern California Edison Company Highgrove Power Plant was delivered from 1952 though 1963 from comingled water supply in the Riverside Water Company Canal, which was produced entirely with San Bernardino County from the Bunker Hill, Colton and Riverside Ground Water Basins. An Allocation of this production, by basin, is shown in Table No. 10.
- Column 6 The Pellissier Ranch, which is owned by the City of Riverside, overlies that portion of the riverside Ground Water Basin situated within San Bernardino County, and water is produced by wells located thereon for overlying use within San Bernardino County. The production from these wells is shown in Table No. 2, Line 20.
- Column 7 Change of ownership to Stapakis, William S., in calendar year 1974.
- Column 8 The delivery to the City of San Bernardino was made during the years of 1959 and 1960 from water produced in the Bunker Hill Basin from the Garner Wells.

TABLE NO. 3

CITY OF RIVERSIDE
DOMESTIC AND IRRIGATION DIVISIONS
DELIVERIES MADE FROM WATER PRODUCED FROM THE BUNKER HILL,
COLTON AND RIVERSIDE GROUNDWATER BASINS SITUATED IN SAN BERNARDINO CO.

(Identification of Deliveries and Amounts Delivered In Acre Feet)

Calendar Year	Riverside Highland Water Co.	Salazar Water Co.	Trujillo Water Co.	Jurupa Ditch Co.	S.C.E. CO. Highgrove Power Plant	Pellissier Ranch	Williams Ranch	Net City of San Bernardino	Overlying Land Use	Total of all Deliveries
	(1)	(2)	(3)	(4)	(5)	(6)	(7)	(8)	(9)	(10)
1984	0	-	220	2,434	-	448	-	9	0	3,111
1985	0	-	168	2,400	-	714	-	0	0	3,282
1986	0	-	6	2,032	-	87	-	292	0	2,417
1987	0	-	11	1,614	-	87	-	319	0	2,031
1988	0	-	15	1,990	-	58	-	769	46	2,878
1989	0	-	7	2,088	-	59	-	0	28	2,182
1990	0	-	10	1,822	-	1,011	-	0	19	2,862
1991	0	-	8	1,511	-	1,005	-	0	155	2,679
1992	0	-	8	1,398	-	334	-	0	203	1,943
1993	0	-	8	947	-	69	-	-198	90	916
1994	0	-	7	1,133	-	72	-	0	7	1,219
1995	0	-	12	1,225	-	0	-	0	1	1,238
1996	0	-	11	1,087	-	0	-	0	268	1,366
1997	0	-	6	1,067	-	0	-	0	486	1,559
1998	0	-	5	1,034	-	0	-	0	0	1,039
1999	0	-	6	1,116	-	0	-	0	0	1,122
2000	0	-	4	997	-	0	-	0	0	1,001
2001	0	-	2	974	-	0	-	0	208	1,184
2002	0	-	2	1,161	-	0	-	0	172	1,335
2003	0	-	5	1,500	-	0	-	0	10	1,515
2004	0	-	5	1,036	-	0	-	0	0	1,041
2005	0	-	5	1,432	-	0	-	0	13	1,450

(1) From City of Riverside Records.

(2) No longer in use.

(3) From City of Riverside Printout, Garner T & G (City source #'s 1203 & 1204) in Riverside

(4) From Table No. 2, Sheet 2, Line 35 + 36. Sheet 3 after 1995

(5) No longer in use.

(6) From Table No. 2, Sheet 2, Lines 21 thru 25. Sheet 3 after 1995

(7) No longer in use.

(8) From City of Riverside Records.

(9) Golf Course irrigation, Thorn 10 and 11.

(10) Total of Column (1) through Column (9).

FOR YEARS PRECEEDING 1971: Refer to Volume 5, August 1976, Page I-21.

TABLE NO. 3

CITY OF RIVERSIDE
DOMESTIC AND IRRIGATION DIVISIONS
DELIVERIES MADE FROM WATER PRODUCED FROM THE BUNKER HILL,
COLTON AND RIVERSIDE GROUNDWATER BASINS SITUATED IN SAN BERNARDINO CO.

(Identification of Deliveries and Amounts Delivered In Acre Feet)

Calendar Year	Riverside Highland Water Co. (1)	Salazar Water Co. (2)	Trujillo Water Co. (3)	Jurupa Ditch Co. (4)	S.C.E. CO. Highgrove Power Plant (5)	Pellissier Ranch (6)	Williams Ranch (7)	Net City of San Bernardino (8)	Overlying Land Use (9)	Blowoff returned to Basin (9a)	Total of all Deliveries (10)
2006	0	-	6	1,208	-	0	-	0	30		1,244
2007	0	-	3	1,414	-	0	-	0	39		1,456
2008	0	-	5	987	-	0	-	0	0	70	1,062
2009	0	-	4	1,122	-	0	-	0	0	121	1,247
2010	0	-	3	978	-	0	-	0	2	78	1,061
2011	0	-	3	1,071	-	0	-	0	0	72	1,146
2012	0	-	4	1,092	-	0	-	0	0	13	1,109
2013		-			-		-				
2014		-			-		-				
2015		-			-		-				
2016		-			-		-				
2017		-			-		-				
2018		-			-		-				
2019		-			-		-				
2020		-			-		-				
2021		-			-		-				
2022		-			-		-				
2023		-			-		-				
2024		-			-		-				
2025		-			-		-				
2026		-			-		-				
2027		-			-		-				
2028		-			-		-				
2029		-			-		-				
2030		-			-		-				

(1) From City of Riverside Records.	(6) From Table No. 2, pages 3 & 4, Line 26
(2) No longer in use.	(7) No longer in use.
(3) From City of Riverside Printout, Garner T & G (City source #'s 1203 & 1204)	(8) From City of Riverside Records. Table 1 page 7 & 8, li
(4) From Table No. 2, page 3 & 4, Line 35 + 36.	(9) Golf Course irrigation, Thorn 10 & 11. Table 1, pages 3 & 4, lines 24 +
(5) No longer in use.	(9a) From City of Riverside Records, Table 2, pg 7 & 8, line 88
	(10) Total of Column (1) through Column (9).

FOR YEARS PRECEEDING 1971: Refer to Volume 5, August 1976, Page I-21.

TABLE NO. 4

CITY OF RIVERSIDE
WATER DELIVERIES TO TRUJILLO WATER CO.
IN SAN BERNARDINO AND RIVERSIDE COUNTIES
 (Quantities in Acre Feet)

Trujillo Water Company Delivery	DELIVERED IN SAN BERNARDINO COUNTY						Delivered in Riverside County
	Year	Ac.Ft. (1)(c)	Individual		Total		
Russell (2)			Pellissier (3)	Proportion (4)	Percent (5)	Ac. Ft. (6)	
1971	300	-	-	-	-	-	300
1972	175	-	-	-	-	-	175
1973	77	-	-	-	-	-	77
1974	73	-	-	-	-	-	73
1975	72	-	-	-	-	-	72
1976	80	-	-	-	-	-	80
1977	76	-	-	-	-	-	76
1978	174	-	-	-	-	-	174
1979	254	-	-	-	-	-	264
1980	328	-	-	-	-	-	328
1981	243	-	-	-	-	-	243
1982	185	-	-	-	-	-	185
1983	158	-	-	-	-	-	158
1984	220	-	-	-	-	-	220
1985	168	-	-	-	-	-	168
1986	6	-	-	-	-	-	6
1987	11	-	-	-	-	-	11
1988	15	-	-	-	-	-	15
1989	7	-	-	-	-	-	7
1990	10	-	-	-	-	-	10
1991	8	-	-	-	-	-	8
1992	8	-	-	-	-	-	8
1993	8	-	-	-	-	-	8
1994	7	-	-	-	-	-	7
1995	12	-	-	-	-	-	12
1996	11	-	-	-	-	-	11
1997	6	-	-	-	-	-	6
1998	5	-	-	-	-	-	5
1999	6	-	-	-	-	-	6
2000	4	-	-	-	-	-	4
2001	2	-	-	-	-	-	2
2002	2	-	-	-	-	-	2
2003	5	-	-	-	-	-	5
2004	5	-	-	-	-	-	5
2005	5	-	-	-	-	-	5

(1) = From Table No. 3, pg 2 & 3, Column 3

(2)(3)(4)(5)(6) are no longer needed.

(c) = Delivered from Garner T & G Well in Riverside Co.

For Years Preceding 1971: Refer to Volume 5, August 1976, Page I-23.

TABLE NO. 4

CITY OF RIVERSIDE
WATER DELIVERIES TO TRUJILLO WATER CO.
IN SAN BERNARDINO AND RIVERSIDE COUNTIES
 (Quantities in Acre Feet)

Trujillo Water Company Delivery	DELIVERED IN SAN BERNARDINO COUNTY						Delivered in Riverside County	
	Individual		Total					
Year	Ac.Ft.		Russell Pellissier	Proportion	Percent	Ac. Ft.	Ac. Ft.	
	(1)	(c)	(2)	(3)	(4)	(5)	(6)	(7)
2006	6		-	-	-	-	-	6
2007	3		-	-	-	-	-	3
2008	5		-	-	-	-	-	5
2009	4		-	-	-	-	-	4
2010	3		-	-	-	-	-	3
2011	3		-	-	-	-	-	3
2012	4		-	-	-	-	-	4
2013			-	-	-	-	-	
2014			-	-	-	-	-	
2015			-	-	-	-	-	
2016			-	-	-	-	-	
2017			-	-	-	-	-	
2018			-	-	-	-	-	
2019			-	-	-	-	-	
2020			-	-	-	-	-	
2021			-	-	-	-	-	
2022			-	-	-	-	-	
2023			-	-	-	-	-	
2024			-	-	-	-	-	
2025			-	-	-	-	-	
2026			-	-	-	-	-	
2027			-	-	-	-	-	
2028			-	-	-	-	-	
2029			-	-	-	-	-	
2030			-	-	-	-	-	
2031			-	-	-	-	-	
2032			-	-	-	-	-	
2033			-	-	-	-	-	
2034			-	-	-	-	-	
2035			-	-	-	-	-	
2036			-	-	-	-	-	
2037			-	-	-	-	-	
2038			-	-	-	-	-	
2039			-	-	-	-	-	
2040			-	-	-	-	-	

(1) = From Table No. 3.

(2)(3)(4)(5)(6) are no longer needed.

(c) = Delivered from Garner T & G Well in Riverside Co., Table 2, page 7 & 8, Ln 59

For Years Preceding 1971: Refer to Volume 5, August 1976, Page I-23.

The following Tables are not needed
after the Base Period Verification Work

City of Riverside

Table Numbered 5, 6, 7

see Volume 5-1974 for data

Table No. 8

Page 1 of 2

CITY OF RIVERSIDE
JURUPA DITCH CO.
WATER PRODUCTION FROM RIVERSIDE BASIN IN SAN BERNARDINO COUNTY
FOR USE IN SAN BERNARDINO CO. AND EXPORTED TO RIVERSIDE CO.

Jurupa Ditch Co. Water Production & Distribution
(Quantities in Acre Feet)

Year	Total Production Jurupa Wells	Distribution	
		Overlying Use in S.B. Co.	Export to Riverside County
(1)	(2)	(3)	(4)
Base Period Average	2,909	39	2,870
1971	2,933	-	2,933
1972	2,884	-	2,884
1973	2,533	-	2,533
1974	2,885	-	2,885
1975	2,866	-	2,866
1976	3,341	-	3,341
1977	2,565	-	2,565
1978	1,085 *	-	1,085
1979	2,234 *	-	2,234
1980	104 **	-	104
1981	1,347	-	1,347
1982	1,489	-	1,489
1983	591	-	591
1984	2,434	-	2,434
1985	2,400	-	2,400
1986	2,032	-	2,032
1987	1,614	-	1,614
1988	1,990	-	1,990
1989	2,088	-	2,088
1990	1,822	-	1,822
1991	1,511	-	1,511
1992	1,398	-	1,398
1993	947	-	947
1994	1,133	-	1,133
1995	1,225	-	1,225
1996	1,087	-	1,087
1997	1,067	-	1,067
1998	1,034	-	1,034
1999	1,116	-	1,116
2000	997	-	997
2001	974	-	974
2002	1,161	-	1,161
2003	1,500	-	1,500
2004	1,036	-	1,036
2005	1,432	-	1,432

* Production From Mason Well

** Includes Mason Well, Jurupa #7 online

Starting in 1984, all production from Jurupa #7 (3602748).

Note: Jurupa 1,3,4,5 destroyed by flooding.

(2) From Table No. 2, sum of active Jurupa (Mason) wells

(3) From City of Riverside Records - all water exported to Riverside County.

(4) Col. 2-Col. 3.

FOR YEARS PRECEDING 1971: Refer to Volume 5, August 1976, Page I-28.

Base Period Average from Base Period Volume 5, Table 8, page 422

TABLE NO. 8

CITY OF RIVERSIDE
JURUPA DITCH CO.
WATER PRODUCTION FROM RIVERSIDE BASIN IN SAN BERNARDINO COUNTY
FOR USE IN SAN BERNARDINO CO. AND EXPORTED TO RIVERSIDE CO.

Jurupa Ditch Co. Water Production & Distribution
 (Quantities in Acre Feet)

Year	Total Production Jurupa Wells	Distribution	
		Overlying Use in S.B. Co.	Export to Riverside County
(1)	(2)*	(3)	(4)
Base Period Average	2,909	39	2,870
2006	1,208	-	1,208
2007	1,414	-	1,414
2008	987	-	987
2009	1,122	-	1,122
2010	978	-	978
2011	1,071	-	1,071
2012	1,092	-	1,092
2013		-	
2014		-	
2015		-	
2016		-	
2017		-	
2018		-	
2019		-	
2020		-	
2021		-	
2022		-	
2023		-	
2024		-	
2025		-	
2026		-	
2027		-	
2028		-	
2029		-	
2030		-	
2031		-	
2032		-	
2033		-	
2034		-	
2035		-	
2036		-	
2037		-	
2038		-	
2039		-	
2040		-	

* All production from Jurupa #7 (3602748).

Note: Jurupa 1,3,4,5 destroyed by flooding.

(2) from Table 2, pg 4, columns 35 + 36 or Table 3, pg 3, column 4

(3) From City of Riverside Records - all water exported to Riverside County.

(4) Col. 2- Col. 3.

FOR YEARS PRECEDING 1971: Refer to Volume 5, August 1976, Page I-28.

Base Period Average from Base Period Volume 5, Table 8, page 422

CITY OF RIVERSIDE
IRRIGATION DIVISION
Production Delivered to Former Riverside Water Company Canal
And Distribution of Production Delivered to Salazar Water Co.

(Quantities in Acre Feet)

SUB-ROUTINE TO ASCERTAIN COMPONENTS OF COMMINGLED WATER APPURTENANT TO SALAZAR DELIVERY AND EXPORTED TO RIVERSIDE COUNTY

Calendar Year	BUNKER HILL BASIN											Percent of Water Production In Canal, from Ground Water Basins			Total Production Delivered to Salazar Water Co. exported to Riverside County				
	Total Prod. Irrig. Division	Less Deliveries in Basin				Domestic Water to Canal from Bunker Hill Basin	Total c Bunker Hill Basin to	Colton Basin Johnson Vaughn Meeks	Total Prod. To Canal Bunker Hill	Riverside Basin Flume Wells 1-2-3-4-5 To *Dom. To Canal	From Bunker Hill Basin	From Colton Basin	From Riverside Basin	Total Delivery	From Bunker Hill Basin	From Colton Basin	From Riverside Basin		
		Riverside Highland Water Co.	City of Riverside Domestic System	City of San Bernardino	Sub Total Deliveries Above Bunker Hill Dike														
(1)	(2)	(3)	(4)	(5)	(6)	(7)	(8)	(9)	10a	(10)	(11)	(12)	(13)	(14)	(15)	(16)	(17)	(18)	
1971	10,817	0	9,822	0	9,822	995	0	995	2,696	276	748	4,439	22.41%	60.73%	16.85%	0	0	0	0
1972	8,471	0	8,216	0	8,216	255	0	255	2,521	1,576	1,180	3,956	6.45%	63.73%	29.83%	0	0	0	0
1973	5,708	0	5,681	0	5,681	27	0	27	101	1,864	544	672	4.02%	15.03%	80.95%	0	0	0	0
1974	7,411	279	7,041	0	7,320	91	0	91	1,386	0	1,588	3,065	2.97%	45.22%	51.81%	0	0	0	0
1975	10,049	0	8,333	0	8,333	1,716	0	1,716	2,545	0	2,071	6,332	27.10%	40.19%	32.71%	0	0	0	0
1976	7,605	0	7,537	0	7,537	68	0	68	853	0	2,452	3,373	2.02%	25.29%	72.69%	0	0	0	0
1977	5,926	0	5,914	0	5,914	12	0	12	295	0	1,199	1,506	0.80%	19.59%	79.61%	0	0	0	0
1978	6,261	0	6,261	0	6,261	0	0	0	464	0	8	472	0.00%	98.31%	1.69%	0	0	0	0
1979	7,357	0	7,357	0	7,357	0	0	0	5	0	97	102	0.00%	4.90%	95.10%	0	0	0	0
1980	6,261	0	6,261	0	6,261	0	0	0	5	0	11	16	0.00%	31.25%	68.75%	0	0	0	0
1981	5,044	0	5,010	0	5,010	34	0	34	77	0	21	132	25.76%	58.33%	15.91%	0	0	0	0

TABLE NOT REQUIRED, WATER NO LONGER DELIVERED

*Grand Avenue Booster
Prod.- Production

Starts Operating October 1966

Domestic Division Total (Table 1, Set 1, Line 30). Less Thorn 2 thru 11 (irrigation use)

- (1) From Table No. 1, Sub Total Sheet 1
- (2) From Table No.3, Page1, Column (1)
- (3) Col. 1 - (Production from Thorn 1-11)
- (4) From Table No. 3, Page 1,Column (8)
- (5) Columns (2) + (3) + (4)
- (6) Column (1)-Column (5)
- (7) From City of Riverside Records
- (8) Column (6) + Column (7)
- (9) From Table No. 2, Sheet 1, Page 1, Line 10
- (10) From Table No. 2, Sheet 1, Line 18 Less Grand Ave. Booster to Domestic
- (11) Columns (8) + (9) + (10)
- (12) Column (8) / Column (11)
- (13) Column (9) / Column (11)
- (14) Column (10) / Column (11)
- (15) From Table No. 3, Column (2)
- (16) Column (15) x Column (12)
- (17) Column (15) x Column (13)
- (18) Column (15) x Column (14)

SALAZAR WATER CO. MAKES NO DELIVERIES IN SAN BERNARDINO COUNTY
 FOR YEARS PRECEEDING 1971: Refer to Volume 5, August 1976, Page 1-30.

TABLE NO. 10

CITY OF RIVERSIDE
IRRIGATION DIVISION
Production Delivered to Former Riverside Water Company Canal
And Distribution of Production Delivered to Southern California Edison Co.
Highgrove Power Plant
(Quantities in Acre Feet)

SUB-ROUTINE TO ASCERTAIN COMPONENTS OF COMMINGLED WATER APPURTENANT TO S.C.E. CO. HIGHGROVE POWER PLANT DELIVERY

Calendar Year	BUNKER HILL BASIN									Percent of Water Production In Canal, from Ground Water Basins			Southern California Edison Co. Highgrove Power Plant Deliveries						
	Total Prod. Irrig. Division	Less Deliveries in Basin					water to Canal from Bunker Hill Basin	Domestic No. 1 Well to Canal	Total Bunker Hill Basin	Colton Basin Johnson Vaughn Meeks Mill	Total Prod. To Canal Bunker Hill Colton and Riverside	From Bunker Hill Basin	From Colton Basin	From Riverside Basin	Total Delivery	From Bunker Hill Basin	From Colton Basin	From Riverside Basin	
		City of Riverside	City of San Bernardino	Sub Total Deliveries Above Bunker Hill Dike	City of Riverside	City of San Bernardino													
		Highland Water Co.	Domestic System	City of San Bernardino	City of Riverside	City of San Bernardino													
(1)	(2)	(3)	(4)	(5)	(6)	(7)	(8)	(9)	10a	(10)	(11)	(12)	(13)	(14)	(15)	(16)	(17)	(18)	
1971	10,817	0	9,822	0	9,822	995	0	995	2,696	276	748	4,439	22.41%	60.73%	16.85%	0	0	0	0
1972	8,471	0	8,216	0	8,216	255	0	255	2,521	1,576	1,180	3,956	6.45%	63.73%	29.83%	0	0	0	0
1973	5,708	0	5,681	0	5,681	27	0	27	101	1,864	544	672	4.02%	15.03%	80.95%	0	0	0	0
1974	7,411	279	7,041	0	7,320	91	0	91	1,386	0	1,588	3,065	2.97%	45.22%	51.81%	0	0	0	0
1975	10,049	0	8,333	0	8,333	1,716	0	1716	2,545	0	2,071	6,332	27.10%	40.19%	32.71%	0	0	0	0
1976	7,605	0	7,537	0	7,537	68	0	68	853	0	2,452	3,373	2.02%	25.29%	72.69%	0	0	0	0
1977	5,926	0	5,914	0	5,914	12	0	12	295	0	1,199	1,506	0.80%	19.59%	79.61%	0	0	0	0
1978	6,261	0	6,261	0	6,261	0	0	0	464	0	8	472	0.00%	98.31%	1.69%	0	0	0	0
1979	7,357	0	7,357	0	7,357	0	0	0	5	0	97	102	0.00%	4.90%	95.10%	0	0	0	0
1980	6,261	0	6,261	0	6,261	0	0	0	5	0	11	16	0.00%	31.25%	68.75%	0	0	0	0
1981	5,044	0	5,010	0	5,010	34	0	34	77	0	21	132	25.76%	58.33%	15.91%	0	0	0	0

TABLE NOT REQUIRED, WATER NO LONGER DELIVERED

*Grand Avenue Booster Starts Operating October 1966
Prod.- Production

- | | | |
|---|---|-----------------------------------|
| (1) From Table No. 1, Sub Total Sheet 1 | (7) From City of Riverside Records | (13) Column (9) / Column (11) |
| (2) From Table No.3, Page1, Column (1) | (8) Column (6) + Column (7) | (14) Column (10) / Column (11) |
| (3) Col. 1 - (Production from Thorn 1-11) | (9) From Table No. 2, Sheet 1, Page 1, Line 10 | (15) From Table No. 3, Column (2) |
| (4) From Table No. 3, Page 1,Column (8) | (10) From Table No. 2, Sheet 1, Line 18 Less Grand Ave. Booster to Domestic | (16) Column (15) x Column (12) |
| (5) Columns (2) + (3) + (4) | (11) Columns (8) + (9) + (10) | (17) Column (15) x Column (13) |
| (6) Column (1)-Column (5) | (12) Column (8) / Column (11) | (18) Column (15) x Column (14) |

FOR YEARS PRECEEDING 1971: Refer to Volume 5, August 1976, Page 1-30.

TABLE NO. 11

CITY OF RIVERSIDE
DOMESTIC & IRRIGATION DIVISIONS
WATER PRODUCTION & DELIVERIES
FROM
COLTON BASIN

WATER PRODUCTION FROM COLTON GROUND WATER BASIN IN
SAN BERNARDINO COUNTY AND DELIVERIES OF PRODUCTION
MADE NORTH OF THE COUNTY LINE IN SAN BERNARDINO COUNTY
AND SOUTH OF THE COUNTY LINE IN RIVERSIDE COUNTY
(Quantities in Acre Feet)

COLTON BASIN PRODUCTION
Delivered in San Bernardino County

Calendar Year	Total Production From Colton Basin	Trujillo Water Company	SCE Co Power Plant Highgrove	Total Deliveries	Total Deliveries Exported to Riverside County
(1)	(2)	(3)	(4)	(5)	(6)
1971	2,696	0	0	0	2,696
1972	2,521	0	0	0	2,521
1973	101	0	0	0	101
1974	1,386	0	0	0	1,386
1975	2,545	0	0	0	2,545
1976	853	0	0	0	853
1977	295	0	0	0	295
1978	464	0	0	0	464
1979	5	0	0	0	5
1980	5	0	0	0	5
1981	77	0	0	0	77

Table not Required, Deliveries No Longer Made

FOR YEARS PRECEDING 1971: Refer to Volume 5,
(2) From Table No 2, Sheet 1, Line 9.
(3) From Table No.4, See Note (C) thereon.
(4) From Table No, 10, Column (17).
(S) Column (3) + Column (4),
(6) Column (2) - Column (5),

TABLE NO. 12

CITY OF RIVERSIDE
DOMESTIC & IRRIGATION DIVISIONS
WATER PRODUCTION & DELIVERIES
FROM
THE RIVERSIDE BASIN

WATER PRODUCTION FROM THAT PORTION OF THE RIVERSIDE GROUND WATER BASIN SITUATED
 NORTH OF THE COUNTY LINE IN SAN BERNARDINO COUNTY AND DELIVERIES OF PRODUCTION MADE
 NORTH OF THE COUNTY LINE IN SAN BERNARDINO COUNTY AND SOUTH OF THE RIVERSIDE COUNTY LINE
 (Quantities in Acre Feet)

Riverside Basin production in San Bernardino County
 Delivered in San Bernardino County

Year	Total Production from Riverside North Basin	Trujillo Water Company	S.C.E. Co. Highgrove Power Plant	Overlying Land Use			Total Deliveries	Total Deliveries Exported to Riverside County
	(2)	(3)	(4)	Pellissier Ranch	Williams Ranch	Jurupa Ranch	(8)	(9)
1971	4,537	0	0	174	0	0	174	4,363
1972	5,920	0	0	107	0	0	107	5,813
1973	4,986	0	0	45	0	0	45	4,941
1974	6,123	0	0	111	0	0	111	6,012
1975	5,838	0	0	94	0	0	94	5,744
1976	6,345	0	0	126	0	0	126	6,219
1977	4,112	0	0	279	0	0	279	3,833
1978	1,364	0	0	271	0	0	271	1,093
1979	2,836	0	0	587	0	0	587	2,249
1980	1,706	0	0	1,591	0	0	1,591	115
1981	2,894	0	0	1,526	0	0	1,526	1,368
1982	3,615	0	0	2,102	0	0	2,102	1,513

Column (2) From Table No. 2, Sheet 1, Page 1, Line 43. Columns (6) & (7): Property sold, Williams rights retained.

Column (3) From Table 4, See Note (c).

Column (8) = Columns (3) + (4) + (5) + (6) + (7).

Column (4) From Table No. 10, Column (18).

Column (9) = Columns (2) - (9).

Column (5) From Table No. 2, Sheet 1, Page 1, Line 26.

TABLE NO. 12

CITY OF RIVERSIDE
DOMESTIC & IRRIGATION DIVISIONS
WATER PRODUCTION & DELIVERIES
FROM
THE RIVERSIDE BASIN

WATER PRODUCTION FROM THAT PORTION OF THE RIVERSIDE GROUND WATER BASIN SITUATED
 NORTH OF THE COUNTY LINE IN SAN BERNARDINO COUNTY AND DELIVERIES OF PRODUCTION MADE
 NORTH OF THE COUNTY LINE IN SAN BERNARDINO COUNTY AND SOUTH OF THE RIVERSIDE COUNTY LINE
 (Quantities in Acre Feet)

Riverside Basin production in San Bernardino County
 Delivered in San Bernardino County

Year	Total Production from Riverside North Basin	Trujillo Water Company	S.C.E. Co. Highgrove Power Plant	Overlying Land Use			Total Deliveries	Total Deliveries Exported to Riverside County
				Pellissier Ranch	Williams Ranch	Jurupa Ranch		
	(2)	(3)	(4)	(5)	(6)	(7)	(8)	(9)
1983	2,581	-	-	1,933	-	-	1,933	648
1984	2,891	-	-	448	-	-	448	2,443
1985	3,193	-	-	714	-	-	714	2,479
1986	2,342	-	-	117	-	-	117	2,225
1987	1,762	-	-	87	-	-	87	1,675
1988	3,315	-	-	58	-	-	58	3,257
1989	10,194	-	-	59	-	-	59	10,135
1990	10,983	-	-	1,011	-	-	1,011	9,972
1991	13,203	-	-	1,005	-	-	1,005	12,198
1992	10,343	-	-	334	-	-	334	10,009
1993	9,300	-	-	69	-	-	69	9,231
1994	8,203	-	-	72	-	-	72	8,131
1995	10,755	-	-	0	-	-	0	10,755
1996	9,064	-	-	0	-	-	0	9,064
1997	8,169	-	-	0	-	-	0	8,169
1998	6,765	-	-	0	-	-	0	6,765
1999	8,883	-	-	0	-	-	0	8,883
2000	8,629	-	-	0	-	-	0	8,629
2001	7,288	-	-	0	-	-	0	7,288
2002	7,814	-	-	0	-	-	0	7,814
2003	6,390	-	-	0	-	-	0	6,390
2004	5,123	-	-	0	-	-	0	5,123
2005	7,829	-	-	0	-	-	0	7,829

Column (2) From Table No. 2, Sheet 1, page 2 or 3, Line 43. Columns (6) & (7): Property sold, Williams rights retained.
 Column (3) From Table 4, See Note (c). Column (8) = Columns (3) + (4) + (5) + (6) + (7).
 Column (4) From Table No. 10, Column (18). Column (9) = Columns (2) - (9).
 Column (5) From Table No. 2, Sheet 1, Page 2 or 3, Line 26.

TABLE NO. 12

CITY OF RIVERSIDE
DOMESTIC & IRRIGATION DIVISIONS
WATER PRODUCTION & DELIVERIES
FROM
THE RIVERSIDE BASIN

WATER PRODUCTION FROM THAT PORTION OF THE RIVERSIDE GROUND WATER BASIN SITUATED
 NORTH OF THE COUNTY LINE IN SAN BERNARDINO COUNTY AND DELIVERIES OF PRODUCTION MADE
 NORTH OF THE COUNTY LINE IN SAN BERNARDINO COUNTY AND SOUTH OF THE RIVERSIDE COUNTY LINE
 (Quantities in Acre Feet)

Riverside Basin production in San Bernardino County
 Delivered in San Bernardino County

Year	Total Production from Riverside North Basin	Trujillo Water Company	S.C.E. Co. Highgrove Power Plant	Overlying Land Use			Total Deliveries	Total Deliveries Exported to Riverside County
				Pellissier Ranch	Williams Ranch	Jurupa Ranch		
(1)	(2)	(3)	(4)	(5)	(6)	(7)	(8)	(9)
2006	10,276	-	-	0	-	-	0	10,276
2007	5,688	-	-	0	-	-	0	5,688
2008	8,802	-	-	0	-	-	0	8,802
2009	13,614	-	-	0	-	-	0	13,614
2010	11,045	-	-	0	-	-	0	11,045
2011	12,043	-	-	0	-	-	0	12,043
2012	13,876	-	-	0	-	-	0	13,876
2013		-	-		-	-		
2014		-	-		-	-		
2015		-	-		-	-		
2016		-	-		-	-		
2017		-	-		-	-		
2018		-	-		-	-		
2019		-	-		-	-		
2020		-	-		-	-		
2021		-	-		-	-		
2022		-	-		-	-		
2023		-	-		-	-		
2024		-	-		-	-		
2025		-	-		-	-		

Column (2) From Table No. 2, Sheet 1, Page 3, Line 43. Page 4 in 2011
 Column (3) From Table 4, See Note (c).
 Column (4) From Table No. 10, Column (18).
 Column (5) From Table No. 2, Sheet 1, pg 3, Line 26. Page 4 in 2011

Columns (6) & (7): Property sold, Williams rights retained.
 Column (8) = Columns (3) + (4) + (5) + (6) + (7).
 Column (9) = Columns (2) - (9).

TABLE NO. 13

CITY OF RIVERSIDE
WATER PRODUCTION FROM SAN BERNARDINO BASIN AREA
AND DELIVERIES WITHIN SAN BERNARDINO COUNTY AND EXPORT TO RIVERSIDE COUNTY
 (Quantities in Acre Feet)

Year	CITY PRODUCTION & DELIVERY IN SAN BERNARDINO BASIN AREA			CITY DELIVERIES IN COLTON & RIVERSIDE BASINS IN SAN BERNARDINO COUNTY				Total Water From San Bernardino Basin Area Exported to Riverside County
	City Wells	Deliveries in San Bernardino Basin Area	Total City Production Available for Export	Prior Right Delivered to Riverside Highland Water Company	Trujillo Water Company	Edison Power Plant	Total	
	(1)	(2)	(3)	(4)	(5)	(6)	(7)	(8)
1971	24,939	0	24,939	0	-	-	0	24,939
1972	20,474	0	20,474	0	-	-	0	20,474
1973	21,493	0	21,493	0	-	-	0	21,493
1974	27,420	0	27,420	65	-	-	65	27,355
1975	25,248	0	25,248	0	-	-	0	25,248
1976	22,085	0	22,085	0	-	-	0	22,085
1977	18,900	0	18,900	0	-	-	0	18,900
1978	19,055	0	19,055	0	-	-	0	19,055
1979	21,561	0	21,561	0	-	-	0	21,561
1980	18,875	0	18,875	0	-	-	0	18,875
1981	20,363	0	20,363	0	-	-	0	20,363
1982	19,522	146	19,376	0	-	-	0	19,376
1983	25,681	144	25,537	0	-	-	0	25,537
1984	25,031	9	25,022	0	-	-	0	25,022
1985	31,817	0	31,817	0	-	-	0	31,817
1986	25,996	292	25,704	0	-	-	0	25,704
1987	25,528	319	25,209	0	-	-	0	25,209
1988	26,490	815	25,675	0	-	-	0	25,675
1989	21,129	28	21,101	0	-	-	0	21,101
1990	20,942	19	20,923	0	-	-	0	20,923
1991	26,133	155	25,978	0	-	-	0	25,978
1992	24,783	203	24,580	0	-	-	0	24,580
1993	25,567	-108	25,675	0	-	-	0	25,675
1994	25,724	7	25,717	0	-	-	0	25,717
1995	23,316	1	23,315	0	-	-	0	23,315

Column (1) = From Table No. 1, Sheet 2, Page 5, Line 61, thru 1982, C of R production

Column (1) = From Table No. 1, Sheet 2, Page 6, Line 64, C of R production

Column (2) = From Table No. 3, Columns (8) + (9).

Column (3) = Column (1) - Column (2).

FOR YEARS PRECEDING 1971: Refer to Volume 5, August 1976, Page I-28.

Column (4) = Table No. 22, Column (2).

Column (5) = Table No. 4, Column (1), Note "C".

Column (6) = Table No. 10, Column (16).

Column (7) = Columns (4) + (5) + (6).

Column (8) = Column (3) - (7).

TABLE NO. 13

CITY OF RIVERSIDE
WATER PRODUCTION FROM SAN BERNARDINO BASIN AREA
AND DELIVERIES WITHIN SAN BERNARDINO COUNTY AND EXPORT TO RIVERSIDE COUNTY
 (Quantities in Acre Feet)

Year	CITY PRODUCTION & DELIVERY IN SAN BERNARDINO BASIN AREA			CITY DELIVERIES IN COLTON & RIVERSIDE BASINS IN SAN BERNARDINO COUNTY				Total Water From San Bernardino Basin Area Exported to Riverside County
	City Wells	Deliveries in San Bernardino Basin Area	Total City Production Available for Export	Prior Right Delivered to Riverside Highland Water Company	Trujillo Water Company	Edison Power Plant	Total	
	(1)	(2)	(3)	(4)	(5)	(6)	(7)	(8)
1996	29,351	268	29,083	0	-	-	0	29,083
1997	27,621	486	27,135	0	-	-	0	27,135
1998	24,210	0	24,210	0	-	-	0	24,210
1999	25,435	0	25,435	0	-	-	0	25,435
2000	28,257	0	28,257	0	-	-	0	28,257
2001	23,042	208	22,834	0	-	-	0	22,834
2002	28,604	172	28,432	0	-	-	0	28,432
2003	21,836	10	21,826	0	-	-	0	21,826
2004	20,525	0	20,525	0	-	-	0	20,525
2005	14,966	13	14,953	0	-	-	0	14,953
2006	17,653	30	17,623	0	-	-	0	17,623
2007	19,694	39	19,655	0	-	-	0	19,655
2008	20,835	70	20,765	0	-	-	0	20,765
2009	8,511	121	8,390	0	-	-	0	8,390
2010	12,333	80	12,253	0	-	-	0	12,253
2011	16,697	72	16,625	0	-	-	0	16,625
2012	16,384	13	16,371	0	-	-	0	16,371
2013					-	-		
2014					-	-		
2015					-	-		
2016					-	-		
2017					-	-		
2018					-	-		
2019					-	-		
2020					-	-		
2021								
2022								
2023								
2024								
2025								

Column (1) = From Table No. 1, Sheet 2, pg 7, Line 64, thru 2010, the pg 8 starting with 2011

Column (2) = From Table No. 3, Columns (8) + (9) + (9a)

Column(3) = Column (1) - Column (2).

FOR YEARS PRECEDING 1971: Refer to Volume 5, August 1976, Page I-28.

Column (4) = Table No. 22, Column (2).

Column (5) = Table No. 4, Column (1), Note "C".

Column (6) = Table No. 10, Column (16).

Column (7) = Columns (4) + (5) + (6).

Column (8) = Column (3) - (7).

Column (2) is where SBBA blowoff water is deducted starting in 2008, is reported in Table 3, Page 3, Column (9a)

TABLE NO. 14

CITY OF RIVERSIDE AND UNIVERSITY OF CALIFORNIA
EXTRACTIONS FROM BUNKER HILL BASIN
IN SAN BERNARDINO BASIN AREA
(Quantities in Acre Feet)

Year	City of Riverside Extractions From Bunker Hill Basin		University of California Extractions From Bunker Hill Basin		Total City & University Extractions From Bunker Hill Basin	
	Amended Filings Ac. Ft.	Original Filings Ac. Ft.	Amended Filings Ac. Ft.	Original Filings Ac. Ft.	Amended Filings Ac. Ft.	Original Filings Ac. Ft.
(1)	(2)	(3)	(4)	(5)	(6)	(7)
1971	24,939	24,939	219	219	25,158	25,158
1972	20,474	20,474	239	239	20,713	20,713
1973	21,493	21,493	239	239	21,732	21,732
1974	27,420	27,420	267	267	27,687	27,687
1975	25,248	25,248	179	179	25,427	25,427
1976	22,085	22,085	245	245	22,330	22,330
1977	18,900	18,900	87	87	18,987	18,987
1978	19,055	20,099 *	183	183	19,238	20,282 *
1979	21,561	21,561	83	83	21,644	21,644
1980	18,875	18,875	7	7	18,882	18,882
1981	20,363	20,363	143	143	20,506	20,506
1982	19,522	19,522	48	48	19,570	19,570

Table Not Needed

1959-1963 Average 24,092 24,061 *550 581 *24,642 24,642

* = Amended Recordation Filings

2 = City of Riverside Table No. 1, Line 61

3 = City of Riverside Original Recordation Filing

4 = University of California Table No. 35, Col. 6

5 = University of California Table No. 35, Col. 7

6 = Col. 2 + Col. 4

7 = Col. 3 + Col. 5

FOR YEARS PRECEDING 1971: Refer to Volume 5, August 1976, Page I-40

Volume 5

Tables 15-18

Gage Canal water production
and distribution

TABLE NO. 15

THE GAGE CANAL COMPANY WATER PRODUCTION
FROM BUNKER HILL BASIN
RIVERSIDE BASIN IN SAN BERNARDINO COUNTY
AND RIVERSIDE BASIN IN RIVERSIDE COUNTY

(Quantities in Acre Feet)

Ln #	Local Designation	State Well #	Recordation #	1971	1972	1973	1974	1975	1976	1977	1978	1979	1980	1981	1982	
<u>BUNKER HILL BASIN IN SAN BERNARDINO BASIN AREA</u>																
1	o No. 6	1S/4W-13L01S	3600784													
2	o No. 17	1S/4W-14R	3600785													
3	No. 21	1S/4W-13L02S	3600786	612	662	710	983	1,117	1,527	2,046	1,286	732	970	1,421	1,341	
4	No. 26-1	1S/4W-23A02S	3600787	1,597	1,241	1,703	1,165	1,358	2,609	2,659	1,538	1,819	1,483	1,679	1,576	
5	No. 27-1	1S/4W-23H01S	3600788	2,010	1,921	1,844	1,152	1,317	225	2,208	1,521	2,381	1,780	1,901	1,606	
6	No. 27-2	1S/4W-23K01S	3600789	1,201	1,224	967	1,325	1,278	1,731	2,021	1,556	2,476	1,440	1,140	1,347	
7	No. 29-1	1S/4W-23K02S	3600790	2,052	1,742	1,567	1,296	951	2,061	2,145	1,255	1,891	1,924	1,444	1,356	
8	No. 29-2	1S/4W-13N01S	3600791	4,365	3,645	3,604	64	3,816	4,720	4,432	3,029	3,282	3,308	4,464	3,517	
9	No. 29-3	1S/4W-13N02S	3600792	3,864	3,220	378	1,241	3,343	3,943	3,843	2,849	2,750	3,299	2,832	3,263	
10	No. 30-1	1S/4W-13M02S	3600793	1,778	1,323	1,499	1,352	1,577	890	1,204	1,594	1,603	1,204	1,754	1,430	
11	No. 31-1	1S/4W-13F02S	3600794	1,266	721	787	1,266	1,154	1,837	289	937	1,749	1,203	1,213	1,244	
12	No. 46-1	1S/4W-13G02S	3600795	3,906	3,431	2,915	2,232	2,508	3,420	3,981	4,774	4,801	5,372	5,010	4,782	
13	No. 51-1	1S/4W-23A05S	3600796	673	616	624	121	4	452	875	775	1,358	967	1,380	1,245	
14	No. 56-1	1S/4W-13G03S	3600797	2,513	2,973	2,436	1,870	2,132	2,923	3,170	2,537	3,389	4,015	3,130	3,896	
15	o Cowlane	1S/4W-23G01S	3600798	-	-	-	-	-	-	-	-	-	-	-	-	
16	No. 66-1	1S/4W-23G	3602331	2,980	2,394	2,415	1,748	2,077	2,855	3,113	2,581	2,558	4,853	4,372	3,425	
17	No. 6-Domestic	1S/4W-13P	3602423	126	107	80	132	82	96	113	97	27	63	54	49	
20	Total Production	Bunker Hill Basin		28,943	25,220	21,529	15,947	22,714	29,289	32,099	26,329	30,816	31,881	31,794	30,077	
22	<u>RIVERSIDE BASIN IN SAN BERNARDINO COUNTY</u>															
24	DeBerry	2S4W-05C01S	3600783	567	778	222	472	645	440	389	734	413	2,032	2,467	1,645	
24b	Total Production	Riverside Basin in S. B. Co.		567	778	222	472	645	440	389	734	413	2,032	2,467	1,645	
26	<u>RIVERSIDE BASIN IN RIVERSIDE COUNTY</u>															
28	Olivewood #1	2S/5W-26F01S	3300366	392	674	550	539	413	253	89	131	352	557	247	176	
29	Olivewood #2	2S/5W-26E02S	3300367	1,026	1,140	908	1,182	789	273	653	614	978	929	399	528	
30	Olivewood #3	22/5W-26M01S	3300368	127	396	404	715	249	52	60	72	64	343	35	180	
32	Total Production	Riverside Basin in Riverside Co.		1,545	2,210	1,862	2,436	1,451	578	802	817	1,394	1,829	681	884	
33a	Gage Total Production	All Basins		31,055	28,208	23,613	18,855	24,810	30,307	33,290	27,880	32,623	35,742	34,942	32,606	
34	ADDITIONAL DELIVERIES FROM OTHER COMPANIES															
36	Riverside Water Co. Booster fro Gage R.W. Co. Stock			-	-	-	-	-	-	-	-	-	-	-	-	
37	City of Riverside - Clearwater Well (Sold to Victoria Count			-	-	-	-	-	-	-	-	-	-	-	-	

o Abandoned &/or File Closed.

Data from C of R Recordation Filings cross checked with Gage's Year End Report.

Line 36 not required because of revision of method for determining quantity of water "not tributary" to Riverside Narrows (see Volume 6)

FOR YEARS PRECEDING 1971: Refer to Volume 5, August 1976, Page I-44

TABLE NO. 15

THE GAGE CANAL COMPANY WATER PRODUCTION
FROM BUNKER HILL BASIN
RIVERSIDE BASIN IN SAN BERNARDINO COUNTY
AND RIVERSIDE BASIN IN RIVERSIDE COUNTY

(Quantities in Acre Feet)

Ln #	Local Designation	State Well #	Recordation #	1983	1984	1985	1986	1987	1988	1989	1990	1991	1992	1993	1994	1995	
<u>BUNKER HILL BASIN IN SAN BERNARDINO BASIN AREA</u>																	
1	o No. 6	1S/4W-13L01S	3600784	0	0	0	0	0	0	0	0	0	0	0	0	0	
2	o No. 17	1S/4W-14R	3600785	0	0	0	0	0	0	0	0	0	0	0	0	0	
3	o No. 21	1S/4W-13L02S	3600786	621	742	985	1,213	1,097	1,560	919	678	588	679	630	880	0	
4	No. 26-1	1S/4W-23A02S	3600787	1,147	2,208	2,021	1,645	2,121	3,074	2,428	1,815	2,106	2,311	1,937	1,095	1,476	
5	No. 27-1	1S/4W-23H01S	3600788	1,417	2,544	2,013	1,940	2,061	3,047	1,773	1,723	1,878	1,590	1,551	1,528	1,990	
6	No. 27-2	1S/4W-23K01S	3600789	872	2,127	2,332	1,866	2,561	3,537	2,521	2,468	2,023	2,418	2,377	2,565	2,555	
7	No. 29-1	1S/4W-23K02S	3600790	1,017	2,265	2,003	1,962	1,778	2,847	1,792	1,564	1,789	1,901	2,208	689	2,355	
8	No. 29-2	1S/4W-13N01S	3600791	2,621	3,630	3,498	4,582	3,583	4,497	3,394	3,747	3,177	2,698	2,226	2,306	1,456	
9	No. 29-3	1S/4W-13N02S	3600792	2,384	4,044	3,152	3,396	4,427	3,912	3,410	2,739	2,921	2,335	2,320	1,681	15	
10	No. 30-1	1S/4W-13M02S	3600793	588	970	1,118	1,233	871	688	1,046	1,884	1,447	1,916	1,611	1,206	787	
11	No. 31-1	1S/4W-13F02S	3600794	1,035	1,444	2,192	2,119	1,225	1,010	1,347	1,251	1,729	2,395	1,987	2,308	1,967	
12	No. 46-1	1S/4W-13G02S	3600795	3,250	5,407	5,050	5,071	4,589	4,839	3,819	3,287	3,558	2,943	2,918	3,039	3,277	
13	No. 51-1	1S/4W-23A05S	3600796	372	1,138	969	1,434	1,428	1,671	975	754	1,003	595	1,274	1,123	0	
14	No. 56-1	1S/4W-13G03S	3600797	2,385	3,525	2,251	3,751	3,249	3,762	3,220	2,225	2,080	1,490	1,892	1,777	13	
15	o Cowlane	1S/4W-23G01S	3600798	0	0	0	0	0	0	0	0	0	0	0	0	0	
16	No. 66-1	1S/4W-23G	3602331	2,630	3,759	3,607	3,714	3,261	3,526	2,975	2,521	2,439	2,117	2,194	2,354	2,196	
17	No. 6-Domestic	1S/4W-13P	3602423	44	72	65	57	62	52	36	39	38	68	76	70	60	
18	No. 92-3	1S/4W-13L08S	3603556											1,005	3,705	4,437	
19	No. 92-2	1S/4W-13L07S	3603557											233	4,023	4,489	
20	No. 92-1	1S/4W-13N07S	3603558											0	4,374	5,003	
21																	
22																	
23																	
24																	
25	Total Production	Bunker Hill Basin		20,383	33,875	31,256	33,983	32,313	38,022	29,655	26,695	26,776	25,456	26,439	34,723	32,076	
26																	
27	<u>RIVERSIDE BASIN IN SAN BERNARDINO COUNTY</u>																
28																	
29	DeBerry	2S4W-05C01S	3600783	1,019	2,046	1,861	1,893	1,996	2,189	1,965	1,962	1,734	1,657	2,023	2,028	1,664	
30																	
31	Total Production	Riverside Basin in S. B. Co.		1,019	2,046	1,861	1,893	1,996	2,189	1,965	1,962	1,734	1,657	2,023	2,028	1,664	
32																	
33	<u>RIVERSIDE BASIN IN RIVERSIDE COUNTY</u>																
34																	
35	Olivewood #1	2S/5W-26F01S	3300366	80	787	535	680	521	463	1,677	1,869	1,446	666	435	855	555	
36	Olivewood #2	2S/5W-26E02S	3300367	301	1,306	968	1,091	910	1,045	1,954	2,136	1,773	795	802	1,402	930	
37	Olivewood #3	22/5W-26M01S	3300368	44	694	487	485	336	576	1,239	1,300	940	324	265	531	354	
38																	
39	Total Production	Riverside Basin in Riverside		425	2,787	1,990	2,256	1,767	2,084	4,870	5,305	4,159	1,785	1,502	2,788	1,839	
40																	
41	Gage Total Production			21,827	38,708	35,107	38,132	36,076	42,295	36,490	33,962	32,669	28,898	29,964	39,539	35,579	

o Abandoned &/or File Closed.

Data from C of R Recordation Filings cross checked with Gage's Year End Report.

THE GAGE CANAL COMPANY WATER PRODUCTION
FROM BUNKER HILL BASIN
RIVERSIDE BASIN IN SAN BERNARDINO COUNTY
AND RIVERSIDE BASIN IN RIVERSIDE COUNTY

(Quantities in Acre Feet)

Ln #	Local Designation	State Well #	Recordation #	1996	1997	1998	1999	2000	2001	2002	2003	2004	2005	2006	2007	2008	2009	2010	
<u>BUNKER HILL BASIN IN SAN BERNARDINO BASIN AREA</u>																			
1	o No. 6	1S/4W-13L01S	3600784	-	-	-	-	-	-	-	-	-	-	-	-	-	-	-	
2	o No. 17	1S/4W-14R	3600785	-	-	-	-	-	-	-	-	-	-	-	-	-	-	-	
3	o No. 21	1S/4W-13L02S	3600786	-	-	-	-	-	-	-	-	-	-	-	-	-	-	-	
4	No. 26-1	1S/4W-23A02S	3600787	1,895	1,996	1,133	2,332	2,685	2,506	3,001	2,530	3,507	2,720	2,911	2,541	1,976	1,422	1,005	
5	No. 27-1	1S/4W-23H01S	3600788	2,237	1,825	1,193	2,702	2,635	2,310	2,352	1,611	2,388	2,261	3,015	2,831	2,647	3,658	2,616	
6	No. 27-2	1S/4W-23K01S	3600789	2,454	2,575	2,282	2,368	1,539	1,339	2,034	1,580	1,636	1,634	1,104	1,466	823	1,631	1,787	
7	No. 29-1	1S/4W-23K02S	3600790	1,495	2,224	1,733	2,459	2,062	2,099	1,949	1,314	710	1,643	1,402	1,669	1,242	1,444	1,197	
8	No. 29-2	1S/4W-13N01S	3600791	1,767	1,400	1,558	1,652	2,323	2,281	1,354	1,876	2,880	2,423	609	2,815	3,491	2,568	3,029	
9	No. 29-3	1S/4W-13N02S	3600792	1	311	727	804	1,655	1,780	2,609	3,894	3,941	2,478	2,624	2,505	2,167	1,816	1,885	
10	No. 30-1	1S/4W-13M02S	3600793	1,321	1,030	1,071	1,240	691	843	1,152	916	650	366	604	563	299	100	138	
11	No. 31-1	1S/4W-13F02S	3600794	1,980	1,933	1,567	902	1,242	1,443	2,026	1,913	1,285	131	2,431	1,396	579	666	654	
12	o No. 46-1	1S/4W-13G02S	3600795	3,249	2,329	2,945	2,829	1,758	2,096	3,411	2,711	2,773	2,924	2,257	851	-	-	-	
13	No. 51-1	1S/4W-23A05S	3600796	1,429	1,681	1,573	1,756	1,166	1,686	940	1,018	236	1,510	1,517	1,770	1,408	825	1,355	
14	No. 56-1	1S/4W-13G03S	3600797	2,346	1,728	1,710	2,034	1,791	1,485	2,131	1,855	1,287	1,019	1,564	933	768	1,222	902	
15	o Cowlane	1S/4W-23G01S	3600798	-	-	-	-	-	-	-	-	-	-	-	-	-	-	-	
16	No. 66-1	1S/4W-23G	3602331	2,136	2,264	1,963	2,311	1,411	1,698	1,252	1,148	1,249	643	768	2,172	2,872	2,615	2,035	
17	No. 6-Domestic	1S/4W-13P	3602423	36	37	22	33	38	25	34	45	42	33	6	5	3	7	6	
18	No. 92-3	1S/4W-13L08S	3603556	4,028	3,804	3,555	3,916	3,762	3,468	3,274	3,286	2,660	2,633	2,364	2,274	1,511	2,599	2,282	
19	No. 92-2	1S/4W-13L07S	3603557	3,951	3,497	3,816	3,740	3,243	3,458	3,058	2,567	2,555	1,788	1,712	2,073	1,606	2,788	2,837	
20	No. 92-1	1S/4W-13N07S	3603558	3,706	3,683	3,359	3,968	3,049	3,344	1,917	954	1,822	2,507	3,459	3,369	3,376	2,986	2,622	
21	No. 98-1	1S/4W-23A06S	3603728				661	4,165	4,409	4,364	3,460	3,268	3,017	3,444	3,091	2,510	3,310	3,239	
22	Tippecanoe	1S/4W-13F02S	3603920													2,767	2,694	4,000	
23	No. 46-1R	1S/4W-23A07S	3603921													2,701	2,199	1,791	
24																			
25	Total Production Bunker Hill Basin			34,031	32,317	30,207	35,707	35,215	36,270	36,858	32,678	32,889	29,730	31,791	32,324	32,746	34,550	33,380	
26																			
27	<u>RIVERSIDE BASIN IN SAN BERNARDINO COUNTY</u>																		
28																			
29	DeBerry	2S/4W05-C01S	3600783	1,706	1,591	1,823	2,051	1,664	1,491	1,286	1,339	1,125	1,354	1,969	1,870	1,849	1,601	1,074	
30																			
31	Total Production Riverside Basin in S. B. Co.			1,706	1,591	1,823	2,051	1,664	1,491	1,286	1,339	1,125	1,354	1,969	1,870	1,849	1,601	1,074	
32																			
33	<u>RIVERSIDE BASIN IN RIVERSIDE COUNTY</u>																		
34																			
35	Olivewood #1	2S/5W-26F01S	3300366	695	595	800	1,049	634	700	1,228	1,068	1,308	1,094	1,088	933	1,025	712	804	
36	Olivewood #2	2S/5W-26E02S	3300367	912	667	1,184	1,432	1,149	952	1,669	1,432	1,772	1,179	1,542	1,517	1,260	1,281	1,144	
37	Olivewood #3	22/5W-26M01S	3300368	416	407	516	801	594	881	645	722	1,026	706	748	751	907	546	705	
38																			
39	Total Production Riverside Basin in Riverside Co.			2,023	1,669	2,500	3,282	2,377	2,533	3,542	3,222	4,106	2,979	3,378	3,201	3,192	2,539	2,653	
40																			
41	Gage Total Production			37,760	35,577	34,530	41,040	39,256	40,294	41,686	37,239	38,120	34,063	37,138	37,395	37,787	38,690	37,107	

o Abandoned &/or File Closed.
 Data from C of R Recordation Filings cross checked with Gage's Year End Report.

TABLE NO. 15

THE GAGE CANAL COMPANY WATER PRODUCTION
FROM BUNKER HILL BASIN
RIVERSIDE BASIN IN SAN BERNARDINO COUNTY
AND RIVERSIDE BASIN IN RIVERSIDE COUNTY

(Quantities in Acre Feet)

Ln #	Local Designation	State Well #	Recordation #	2011	2012	2013	2014	2015	2016	2017	2018	2019	2020	2021	2022	2023	2024	2025
<u>BUNKER HILL BASIN IN SAN BERNARDINO BASIN AREA</u>																		
1	o No. 6	1S/4W-13L01S	3600784	-	-	-	-	-	-	-	-	-	-	-	-	-	-	-
2	o No. 17	1S/4W-14R	3600785	-	-	-	-	-	-	-	-	-	-	-	-	-	-	-
3	o No. 21	1S/4W-13L02S	3600786	-	-	-	-	-	-	-	-	-	-	-	-	-	-	-
4	No. 26-1	1S/4W-23A02S	3600787	3,091	2,785													
5	No. 27-1	1S/4W-23H01S	3600788		13	2,057												
6	No. 27-2	1S/4W-23K01S	3600789	1,248	713													
7	No. 29-1	1S/4W-23K02S	3600790	746	1,272													
8	No. 29-2	1S/4W-13N01S	3600791	2,041	3,286													
9	No. 29-3	1S/4W-13N02S	3600792	2,417	2,320													
10	No. 30-1	1S/4W-13M02S	3600793	18	0													
11	No. 31-1	1S/4W-13F02S	3600794	131	0													
12	o No. 46-1	1S/4W-13G02S	3600795	-	-	-	-	-	-	-	-	-	-	-	-	-	-	-
13	No. 51-1	1S/4W-23A05S	3600796	1,831	2,172													
14	No. 56-1	1S/4W-13G03S	3600797	783	737													
15	o Cowlane	1S/4W-23G01S	3600798	-	-	-	-	-	-	-	-	-	-	-	-	-	-	-
16	No. 66-1	1S/4W-23G	3602331	899	2,185													
17	No. 6-Domestic	1S/4W-13P	3602423	33	15													
18	No. 92-3	1S/4W-13L08S	3603556	2,604	2,484													
19	No. 92-2	1S/4W-13L07S	3603557	2,639	2,965													
20	No. 92-1	1S/4W-13N07S	3603558	3,524	3,430													
21	No. 98-1	1S/4W-23A06S	3603728	3,387	3,389													
22	Tippecanoe	1S/4W-13F02S	3603920	4,228	3,977													
23	No. 46-1R	1S/4W-23A07S	3603921	158	2,335													
24																		
25	Total Production Bunker Hill Basin			29,791	36,122													
26																		
27	<u>RIVERSIDE BASIN IN SAN BERNARDINO COUNTY</u>																	
28																		
29	DeBerry	2S4W05C01S	3600783	693	1,304													
30																		
31	Total Production Riverside Basin in S. B. Co.			693	1,304													
32																		
33	<u>RIVERSIDE BASIN IN RIVERSIDE COUNTY</u>																	
34																		
35	Olivewood #1	2S/5W-26F01S	3300366	987	924													
36	Olivewood #2	2S/5W-26E02S	3300367	1,361	1,295													
37	Olivewood #3	22/5W-26M01S	3300368	743	385													
38																		
39	Total Production Riverside Basin in Riverside Co.			3,091	2,604													
40																		
41	Gage Total Production			33,575	40,030													

o Abandoned &/or File Closed.

Data from C of R Recordation Filings cross checked with Gage's Year End Report.

TABLE NO. 16

THE GAGE CANAL COMPANY
WATER PRODUCTION FROM BUNKER HILL BASIN
DELIVERED IN SAN BERNARDINO COUNTY & RIVERSIDE COUNTY
TO EAST RIVERSIDE WATER COMPANY

(1)	(2)	(3)	(4)	Delivered		(7)
				San Bernardino County	Riverside	
	Irrigation Season in Days	Total Delivered to East Riverside Water Company in A.F.	Average A.F. per day of Irrigation Season in A.F.	Estimated	Measured	County in A.F.
				in A.F.	in A.F.	
1971						108
1972						90
1973						82
1974						**0
1975						**0
1976						**0
1977						**0
1978						**0
1979						**0
1980						**0
1981						**0
1982						**0

See **, Table No Longer Needed

Columns (2) & (3) Gage Records

Column (4) 632 Ac. Ft. /326 days = 1.94 for Years 1947 through 1952 = Col. (6)/Col. (2)

Column (5) (4) x (2)

Column (6) Gage Canal Records

Column (7) = Column (3) - Column (5) or Column (3) - Column (6)

*From 1968 to 1973, the Gage Canal has provided the Watermaster with just that portion of water delivered to East Riverside Water Co. that was used within San Bernardino County.

** Beginning in 1974 all water delivered to Eat Riverside Co. within San Bernardino Co. was produced by the DeBerry Well which is located in the Riverside Basin withing San Bernardino County

FOR YEARS PRECEDING 1971: Refer to Volume 5, August 1976, Page I-47

TABLE NO. 17

THE GAGE CANAL COMPANY
WATER PRODUCTION FROM BUNKER HILL AND RIVERSIDE BASINS SITUATED IN SAN BERNARDINO COUNTY
WITH DELIVERIES MADE IN SAN BERNARDINO COUNTY & EXPORTED TO RIVERSIDE COUNTY

(Quantities in Acre Feet)

Year	Production in Bunker Hill Basin	Delivery in Bunker Hill Basin			Delivery in Colton Basin				Bunker Hill Export to Riverside Basin in San Bernardino County	Bunker Hill Water Delivered to Riverside Basin North of County Line	Bunker Hill Water Exported to Riverside County	Production in Riverside Basin within San Bernardino County			
		Total Delivery	Southern California Edison Power Plant Return to Canals	Net Delivery	Bunker Hill Export from Basin	Water Rights	Gage Stock	Total Delivery				Delivered to DeBerry Well	Delivered to East Riverside Water Company	Export to Riverside County	
(1)	(2)	(3)	(3a)	(4)	(5)	(6)	(7)	(8)	(9)	(10) *	(11) *	(12)	(13) (14)	(14a)	(15)
1971	28,943	698	600	98	28,845	526	35	561	28,284	108	108	28,176	567	0	567
1972	25,220	708	623	85	25,135	422	35	457	24,678	90	90	24,588	778	0	778
1973	21,529	671	515	156	21,373	331	99	430	20,943	82	82	20,861	222	0	222
1974	15,947	761	1,004	0	15,947	381	104	485	15,462	0	0	15,462	472	98	374
1975	22,714	644	1,099	0	22,714	342	156	498	22,216	0	0	22,216	645	77	568
1976	29,289	1,085	1,137	0	29,289	305	218	523	28,766	0	0	28,766	440	62	378
1977	32,099	1,212	1,338	0	32,099	263	83	346	31,753	0	0	31,753	389	6	383
1978	26,329	781	135	646	25,683	213	88	301	25,382	0	0	25,382	734	4	730
1979	30,816	814	1,057	0	30,816	273	142	415	30,401	0	0	30,401	413	4	409
1980	31,881	631	248	383	31,498	0	0	0	31,498	0	0	31,498	2,032	4	2,028
1981	31,794	724	0	724	31,070	0	0	0	31,070	0	0	31,070	2,467	3	2,464
1982	30,077	451	435	16	30,061	0	0	0	30,061	0	0	30,061	1,645	1	1,644
1983	20,383	191	0	191	20,192	0	0	0	20,192	0	0	20,192	1,019	1	1,018

Column (2) = From Recordation Filings, Table 15, Page 1, I
 Column (3) = From Gage Records.
 Column (3a) = From S.C.E. Co Report to CRWQB.
 Column (4) = Column (3) - Column (3a).
 Column (5) = Column (2) - Column (4).
 Column (6) = From Gage Records.
 Column (7) = From Gage Records.

Column (8) = Column (6) + Column (7).
 Column (9) = Column (5) - Column (8).
 Column (10) = From Table 16, Column (6).
 Column (11) = Same as Column (10).
 Column (12) = Column (9) - Column (11).
 Column (13) = From Table 15, Page 1, Line 24.
 Column (14) = Same as Column (13).

Column (14a) = From Gage Canal records. (Outlets 1,3,5,6,8)
 Commencing in the Year 1974, water supplied by DeBery Well
 Column (15) = Column (14) - Column (14a).
 CRWQCB = California Regional Water Quality Control Board.
 Column 6 comments include water sales to City of Colton

NOTE: DeBERRY WELL WAS FINANCED AND CONSTRUCTED BY THE GAGE CANAL COMPANY STOCKHOLDERS FOR THE SOLE USE OF GAGE STOCKHOLDERS, AND DOES NOT SERVE EAST RIVERSIDE WATER CO. **PRIOR TO 1974.**
 FOR YEAR PRECEDING 1971: Refer to Volume 5, August 1976, Page I-49

TABLE NO. 17

THE GAGE CANAL COMPANY
WATER PRODUCTION FROM BUNKER HILL AND RIVERSIDE BASINS SITUATED IN SAN BERNARDINO COUNTY
WITH DELIVERIES MADE IN SAN BERNARDINO COUNTY & EXPORTED TO RIVERSIDE COUNTY

(Quantities in Acre Feet)

Year	Delivery in Bunker Hill Basin				Delivery in Colton Basin			Bunker Hill Export to Riverside Basin in San Bernardino County	Bunker Hill Wtr Delivered to Riverside Basin North of County Line		Production in Riverside Basin within San Bernardino County			
	Production in Bunker Hill Basin	Southern California Edison Power Plant		Bunker Hill Export from Basin	Cooley Ranch Water Rights Gage/Total		Bunker Hill Water Exported to Riverside County		DeBerry Well	Delivered to East Riverside Water Company	Export to Riverside County			
		Total Delivery	Return to Canals		Net Delivery	(6)						(7) (8)		
(1)	(2)	(3)	(3a)	(4)	(5)	(6)	(7) (8)	(9)	(10) (11) *	(12)	(13)	(14)	(14a)	(15)
1984	33,875	32	0	32	33,843	-		33,843	-	33,843	2,046	2		2,044
1985	31,256	59	0	59	31,197	-		31,197	-	31,197	1,861	1		1,860
1986	33,983	145	0	145	33,838	-		33,838	-	33,838	1,893	2		1,891
1987	32,313	15	0	15	32,298	-		32,298	-	32,298	1,996	1		1,995
1988	38,022	10	15	0	38,022	-		38,022	-	38,022	2,189	2		2,187
1989	29,655	0	-	0	29,655	-		29,655	-	29,655	1,965	2		1,963
1990	26,695	4	-	0	26,695	-		26,695	-	26,695	1,962	1		1,961
1991	26,776	6	-	0	26,776	-		26,776	-	26,776	1,734	1		1,733
1992	25,456	0	-	0	25,456	-		25,456	-	25,456	1,657	1		1,656
1993	26,439	0	-	0	26,439	-		26,439	-	26,439	2,023	2		2,021
1994	34,723	39	-	39	34,684	-		34,684	-	34,684	2,028	2		2,026
1995	32,076	98	-	98	31,978	-		31,978	-	31,978	1,664	0		1,664
1996	34,031	10	-	10	34,021	-		34,021	-	34,021	1,706	0		1,706
1997	32,317	8	-	8	32,309	-		32,309	-	32,309	1,591	0		1,591
1998	30,207	0	-	0	30,207	-		30,207	-	30,207	1,823	0		1,823
1999	35,707	181	-	181	35,526	-		35,526	-	35,526	2,051	0		2,051
2000	35,215	117	-	117	35,098	-		35,098	-	35,098	1,664	0		1,664
2001	36,270	21	-	21	36,249	-		36,249	-	36,249	1,491	0		1,491
2002	36,858	0	-	0	36,858	-		36,858	-	36,858	1,286	0		1,286
2003	32,678	0	-	0	32,678	-		32,678	-	32,678	1,339	0		1,339
2004	32,889	0	-	0	32,889	-		32,889	-	32,889	1,125	0		1,125
2005	29,730	0	-	0	29,730	-		29,730	-	29,730	1,354	-		1,354

Column (2) = From Recordation Filings, Table 15, Line 25 Column (8) = Column (6) + Column (7).

Column (14a) = From Gage Canal records. (Outlets 1,3,5,6,8)

Column (3) = From Gage Records.

Column (9) = Column (5) - Column (8).

Column (15) = Column (14) - Column (14a).

Column (3a) = From S.C.E. Co Report to CRWQCB.

Column (10) = From Table 16, Column (6).

Column (4) = Column (3) - Column (3a).

Column (11) = Same as Column (10).

* All deliveries in San Bernardino Co. from DeBerry Well.

Column (5) = Column (2) - Column (4).

Column (12) = Column (9) - Column (11).

CRWQCB = California Regional Water Quality Control Board.

Column (6) = From Gage Records.

Column (13) = From Table 15, Line 29.

SCE sold Power Plant to Mt. View Power Company in 1999

Column (7) = From Gage Records.

Column (14) = Same as Column (13).

TABLE NO. 17

THE GAGE CANAL COMPANY
 WATER PRODUCTION FROM BUNKER HILL AND RIVERSIDE BASINS SITUATED IN SAN BERNARDINO COUNTY
 WITH DELIVERIES MADE IN SAN BERNARDINO COUNTY & EXPORTED TO RIVERSIDE COUNTY

(Quantities in Acre Feet)

Year	Delivery in Bunker Hill Basin				Delivery in Colton Basin			Production in Riverside Basin within San Bernardino County				
	Production in Bunker Hill Basin	Southern California Edison Power Plant		Bunker Hill Export from Basin	Cooley Ranch Water Rights Gage/Total	Bunker Hill Export to Riverside Basin in San Bernardino County	Bunker Hill Wtr Delivered to Riverside Basin North of County Line	Bunker Hill Water Exported to Riverside County	Production in Riverside Basin			
		Total Delivery	Return to Canals						Net Delivery	Delivered to DeBerry Well	Delivered to East Riverside Water Company	Export to Riverside County
(1)	(2)	(3)	(3a)	(4)	(5)	(6) (7) (8)	(9)	(10) (11) *	(12)	(13) (14)	(14a)	(15)
2006	31,791	-	-	-	31,791	-	31,791	-	31,791	1,969	-	1,969
2007	32,324	-	-	-	32,324	-	32,324	-	32,324	1,870	-	1,870
2008	32,746	-	-	-	32,746	-	32,746	-	32,746	1,849	-	1,849
2009	34,550	-	-	-	34,550	-	34,550	-	34,550	1,601	-	1,601
2010	33,380	-	-	-	33,380	-	33,380	-	33,380	1,074	-	1,074
2011	29,791	-	-	-	29,791	-	29,791	-	29,791	693	-	693
2012	36,122	-	-	-	36,122	-	36,122	-	36,122	1,304	-	1,304
2013		-	-	-		-		-			-	
2014		-	-	-		-		-			-	
2015		-	-	-		-		-			-	
2016		-	-	-		-		-			-	
2017		-	-	-		-		-			-	
2018		-	-	-		-		-			-	
2019		-	-	-		-		-			-	
2020		-	-	-		-		-			-	
2021		-	-	-		-		-			-	
2022		-	-	-		-		-			-	
2023		-	-	-		-		-			-	
2024		-	-	-		-		-			-	
2025		-	-	-		-		-			-	

Column (2) = From Recordation Filings, Table 15, Page 3 or Page 4, Line 25
 Column (5) = Column (2) - Column (4).
 Column (9) = Column (5) - Column (8).
 Column (10) = From Table 16, Column (6).
 Column (11) = Same as Column (10).
 Column (12) = Column (9) - Column (11).

Column (13) = From Table 15, Line 9.
 Column (14) = Same as Column (13).
 Column (14a) = From Gage Canal records. (Outlets 1,3,5,6,8)
 Column (15) = Column (14) - Column (14a).
 * All deliveries in San Bernardino Co. from DeBerry Well.
 SCE sold Power Plant to Mt. View Power Company in 1999

TABLE NO. 18

GAGE CANAL
WATER PRODUCTION FROM SAN BERNARDINO BASIN AREA
AND DELIVERIES WITHIN SAN BERNARDINO COUNTY
AND EXPORTS TO RIVERSIDE COUNTY

(Quantities in Acre Feet)

Year	GAGE CANAL WATER COMPANY PRODUCTION AND DELIVERY IN SAN BERNARDINO BASIN AREA			GAGE DELIVERIES IN COLTON & RIVERSIDE BASINS IN SAN BERNARDINO COUNTY			Total Water From San Bernardino Basin Area Exported to Riverside County
	Production from Gage Wells	Delivery to Power Plant	Total Available for Export	Cooley Stock & Prior Rights	East Riverside Water Company	Total Delivery	
	(1)	(2)	(3)	(4)	(5)	(6)	(7)
Base Period Average	29,999	683	28,800	529	360	889	27,911
1971	28,943	98	28,845	561	108	669	28,176
1972	25,220	85	25,135	457	90	547	24,588
1973	21,529	156	21,373	430	82	512	20,861
1974	15,947	0	15,947	485	-	485	15,462
1975	22,714	0	22,714	498	-	498	22,216
1976	29,289	0	29,289	523	-	523	28,766
1977	32,099	0	32,099	346	-	346	31,753
1978	26,329	646	25,683	301	-	301	25,382
1979	30,816	0	30,816	415	-	415	30,401
1980	31,881	383	31,498	-	-	-	31,498
1981	31,794	724	31,070	-	-	-	31,070
1982	30,077	16	30,061	-	-	-	30,061
1983	20,383	191	20,192	-	-	-	20,192
1984	33,875	32	33,843	-	-	-	33,843
1985	31,256	59	31,197	-	-	-	31,197
1986	33,983	145	33,838	-	-	-	33,838
1987	32,313	15	32,298	-	-	-	32,298
1988	38,022	0	38,022	-	-	-	38,022
1989	29,655	0	29,655	-	-	-	29,655
1990	26,695	0	26,695	-	-	-	26,695
1991	26,776	0	26,776	-	-	-	26,776
1992	25,456	0	25,456	-	-	-	25,456
1993	26,439	0	26,439	-	-	-	26,439
1994	34,723	39	34,684	-	-	-	34,684
1995	32,076	98	31,978	-	-	-	31,978
1996 *	34,031	10	34,021	-	-	-	34,021
1997 *	32,317	8	32,309	-	-	-	32,309
1998 *	30,207	0	30,207	-	-	-	30,207
1999	35,707	181	35,526	-	-	-	35,526
2000	35,215	117	35,098	-	-	-	35,098
2001	36,270	21	36,249	-	-	-	36,249
2002	36,858	0	36,858	-	-	-	36,858
2003	32,678	0	32,678	-	-	-	32,678
2004	32,889	0	32,889	-	-	-	32,889
2005	29,730	0	29,730	-	-	-	29,730

Column (1) = From Table No. 15, Line 20 or 25, Gage Canal.

Column (2) = From Table No. 17, Column (4), Gage Canal.

Column (3) = Column (1) - Column (2).

Column (4) = Table No. 17, Column (8), Gage Canal, Cooley Ranch last took water in 1979.

Column (5) = Table No. 17, Column (11), Gage Canal,

after 1974, all East Riverside Water from DeBerry Well.

Column (6) = Column (4) + Column (5).

Column (7) = Column (3) - Column (6).

FOR YEARS PRECEDING 1971: Refer to Volume 5, August 1976, Page I-51.

* Corrected during 1999 verification

Base Period Average from Base Period Volume 5, page 435

TABLE NO. 18

GAGE CANAL
WATER PRODUCTION FROM SAN BERNARDINO BASIN AREA
AND DELIVERIES WITHIN SAN BERNARDINO COUNTY
AND EXPORTS TO RIVERSIDE COUNTY

(Quantities in Acre Feet)

Year	GAGE CANAL WATER COMPANY PRODUCTION AND DELIVERY IN SAN BERNARDINO BASIN AREA			GAGE DELIVERIES IN COLTON & RIVERSIDE BASINS IN SAN BERNARDINO COUNTY			Total Water From San Bernardino Basin Area Exported to Riverside County
	Production from Gage Wells	Delivery to Power Plant	Total Available for Export	Cooley Stock & Prior Rights	East Riverside Water Company	Total Delivery	
	(1)	(2)	(3)	(4)	(5)	(6)	
Base Period Average	29,999	683	28,800	529	360	889	27,911
2006	31,791	-	31,791	-	-	-	31,791
2007	32,324	-	32,324	-	-	-	32,324
2008	32,746	-	32,746	-	-	-	32,746
2009	34,550	-	34,550	-	-	-	34,550
2010	33,380	-	33,380	-	-	-	33,380
2011	29,791	-	29,791	-	-	-	29,791
2012	36,122	-	36,122	-	-	-	36,122
2013		-		-	-	-	
2014		-		-	-	-	
2015		-		-	-	-	
2016		-		-	-	-	
2017		-		-	-	-	
2018		-		-	-	-	
2019		-		-	-	-	
2020		-		-	-	-	
2021		-		-	-	-	
2022		-		-	-	-	
2023		-		-	-	-	
2024		-		-	-	-	
2025		-		-	-	-	
2026		-		-	-	-	
2027		-		-	-	-	
2028		-		-	-	-	
2029		-		-	-	-	
2030		-		-	-	-	

Column (1) = From Table No. 15, Line 25, Gage Canal.

Column (3) = Column (1) - Column (2).

Column (7) = Column (3) - Column (6).

FOR YEARS PRECEDING 1971: Refer to Volume 5, August 1976, Page I-51.

Base Period Average from Base Period Volume 5, page 435

Volume 5

Tables 19-31A

Riverside Highland Water
Company Water production and
distribution

TABLE NO. 19

RIVERSIDE HIGHLAND WATER COMPANY WATER PRODUCTION
 FROM LYTLE & BUNKER HILL BASINS
 IN SAN BERNARDINO BASIN AREA
 (Quantities in Acre Feet)

Year	L.C. #1 1N4W31E01S	L.C. #8 1N4W31E01S	L.C. #10 1N4W31E03S	Lyle Creek Basin Sub-Total	R.H. #1 1S4W22M07S	R.H. #2 1S4W22L	R.H. FW#5 1S4W22L17S	Cooley H 1S4W11D02S	Cooley I 1S4W11D03S	Cooley J 1S4W11D04S	Raub 6 1S4W14N10S	Raub 8 1S4W14N10S	R.H. #12 ° 1S4W22L08S	R.H. #18 1S4W22L05S	R.H. #24 1S4W22P05S	Bunker Hill Basin Sub-Total	Total Water Production San Bernardino Basin Area	High Groundwater Mitigation Program
(1)	(2)	(3)	(4)	(5)	(6)	(7)	(8)	(9)	(10)	(11)	(11a)	(11b)	(12)	(13)	(14)	(15)	(16)	(17)
	3601535	3602840	3603470		3601522	3601523	3603514	3604003	3604004	3604010	3603907	3603908	3601530	3601533	3602254		4,294	
Adjusted Base Right																		
1971	1,669			1,669	177	313							761	1,092	0	2,343	4,012	
1972	1,468			1,468	0	113							804	1,178	969	3,064	4,532	
1973	1,282			1,282	259	155							772	1,044	0	2,230	3,512	
1974	1,374			1,374	68	146							656	830	1,014	2,714	4,088	
1975	1,302			1,302	14	236							697	1,137	1,323	3,407	4,709	
1976	1,468			1,468	0	28							936	703	1,385	3,052	4,520	
1977	1,406			1,406	0	59							378	983	757	2,177	3,583	
1978	964			964	0	100							142	144	0	386	1,350	
1979	1,352			1,352	0	457							368	351	841	2,017	3,369	
1980	1,600			1,600	0	649							669	37	722	2,077	3,677	
1981	1,806			1,806	0	650							86	915	147	1,798	3,604	
1982	1,538			1,538	0	392							439	227	199	1,257	2,795	
1983	2,248			2,248	0	578							255	81	0	914	3,162	
1984	0	2,300	*	2,300	0	1,293							85	1,081	0	2,459	4,759	
1985	0	1,880	**	1,880	-	809							122	501	-	1,432	3,312	
1986	199	1,939		2,138	-	1,058							1	1,547	-	2,606	4,744	
1987	1,680	490		2,170	-	730							0	1,019	-	1,749	3,919	
1988	1,354	935		2,289	-	1,058							0	1,428	-	2,486	4,775	
1989	1,072	1,068		2,140	-	1,201							0	1,340	-	2,541	4,681	
1990	905	1,084		1,989	-	25	2,047						0	31	-	2,103	4,092	
1991	188	526	473	1,187	-	46	1,736						0	52	-	1,834	3,021	
1992	14	125	2,018	2,157	-	37	1,771						0	87	-	1,895	4,052	
1993	20	933	227	1,180	-	28	1,998						0	35	-	2,061	3,241	
1994	917	960	0	1,877	-	324	1,689						0	434	-	2,447	4,324	
1995	1,164	183	523	1,870	-	33	2,010						0	42	-	2,085	3,955	
1996	996	507	1,379	2,882	-	524	929						0	716	-	2,169	5,051	
1997	520	636	1,675	2,831	-	781	200						0	1,127	-	2,108	4,939	
1998	581	108	1,791	2,480	-	1	0						0	769	-	770	3,250	
1999	123	319	2,378	2,820	-	787	0						0	1,365	-	2,152	4,972	2,041
2000	153	179	2,524	2,856	-	188	6						0	373	-	567	3,423	567
2001	3	1	2,661	2,665	-	76	121						0	63	-	260	2,925	260
2002	1	1	2,398	2,399	-	424	972						0	514	-	1,910	4,309	1,910
2003	0	0	2,260	2,260	-	1	1	1,161	139		0	318	0	1	-	1,621	3,881	3
2004	0	0	1,454	1,454	-	0	1	69	152	76	0	0	1	1	-	300	1,754	-
2005	0	0	1,692	1,692	-	1	1	414	0	26	248	994	1	1	-	1,686	3,378	-

FOR YEARS PRECEDING 1971: Refer to Volume 5, August 1976, Page 1-58.
 L.C. #2, R.H. #8, Flowing, #10, #11 were abandoned &/or Filed Closed before 1971.
 ° Abandoned &/or Filed Closed.

* 1984 L.C. flowed artesian during the year, RH filed on pumped total of 1,891 af. Watermaster calculated 2300 af as reasonable.
 ** 1985 Filed 2,748. Large known loss near well site of 868 af.

Column (5) = Column (2) + (3) + (4).
 Column (15) = Sum of Columns (6) thru Column (14).
 Column (16) = Column (5) + Column (15).
 Adjusted Base Right from Annual Report, Table 11

T is table s o all pro tion ar e a in st RH in l in t e ater oin ire tl into Co R s ste

TABLE NO. 19

**RIVERSIDE HIGHLAND WATER COMPANY WATER PRODUCTION
FROM LYTLE & BUNKER HILL BASINS
IN SAN BERNARDINO BASIN AREA**
(Quantities in Acre Feet)

Year	L.C. #1 1N4W31E01S 3601535	L.C. #8 1N4W31F01S 3602840	L.C. #10 1N4W31E03S 3603470	Lyle Creek Basin Sub-Total	*R.H. #1 1S4W22M07S 3601522	R.H. FW #2 1S4W22L 3601523	R.H. FW#5 1S4W22L17S 3603514	Cooley H 1S4W11D02S 3604003	Cooley I 1S4W11D03S 3604004	Cooley J 1S4W11D04S 3604010	Raub 6 1S4W14N10S 3603907	Raub 8 1S4W14N10S 3603908	R.H. #12 ° 1S4W22L08S 3601530	R.H. #18 1S4W22L05S 3601533	R.H. #24 1S4W22P05S 3602254	Bunker Hill Basin Sub-Total	Total Water Production San Bernardino Basin Area	High Groundwater Mitigation Program
(1)	(2)	(3)	(4)	(5)	(6)	(7)	(8)	(9)	(10)	(11)	(11a)	(11b)	(12)	(13)	(14)	(15)	(16)	(17)
Adjusted Base Right																	4,294	
2006	0	0	2,485	2,485	-	1	1	362	78	0	1,221	0	-	1	-	1,664	4,149	-
2007	0	0	1,985	1,985	-	3	0	303	90	47	0	1,200	-	5	-	1,648	3,633	-
2008	0	0	2,289	2,289	-	1	0	90	350	0	0	0	-	0	-	441	2,730	-
2009	0	0	1,208	1,208	-	0	0	0	440	0	0	0	-	0	-	440	1,648	-
2010	0	0	694	694	-	1	1	440	0	0	0	0	-	0	-	442	1,136	-
2011	0	0	1,210	1,210	-	4	1	440	0	0	0	0	-	0	-	445	1,655	-
2012	0	0	1,694	1,694	-	1	0	414	26	0	0	0	-	0	-	441	2,135	-
2013					-								-		-			-
2014					-								-		-			-
2015					-								-		-			-
2016					-								-		-			-
2017					-								-		-			-
2018					-								-		-			-
2019					-								-		-			-
2020					-								-		-			-
2021					-								-		-			-
2022					-								-		-			-
2023					-								-		-			-
2024					-								-		-			-
2025					-								-		-			-
2026					-								-		-			-
2027					-								-		-			-
2028					-								-		-			-
2029					-								-		-			-
2030					-								-		-			-
2031					-								-		-			-
2032					-								-		-			-
2033					-								-		-			-
2034					-								-		-			-
2035					-								-		-			-
2036					-								-		-			-
2037					-								-		-			-
2038					-								-		-			-
2039					-								-		-			-
2040					-								-		-			-

FOR YEARS PRECEDING 1971: Refer to Volume 5, August 1976, Page I-58.

L.C. #2, R.H. #8, Flowing, #10, #11 were abandoned &/or Filed Closed before 1971.

° Abandoned &/or Filed Closed.

* 1984 L.C. flowed artesian during the year, RH filed on pumped total of 1,891 af. Watermaster calculated 2300 af as reasonable.

** 1985 Filed 2,748. Large known loss near well site of 868 af.

Column (5) = Column (2) + (3) + (4).

Column (15) = Sum of Columns (6) thru Column (14).

Column (16) = Column (5) + Column (15).

Adjusted Base Right from Annual Report, Table 11

T is tables o all pro tion are a ainst RH in l in t e ater oin ire tl into Co R s ste

TABLE NO. 20

page 1 of 2

RIVERSIDE HIGHLAND WATER COMPANY WATER PRODUCTION
FROM COLTON BASIN
 (Quantities in Acre Feet)

Year	R H # 4 1S4W28K01S 3601525	R H # 4A 1S4W28K02S 3602182	Total Production in Colton Basin
(1)	(2)	(3)	(4)
Base Period Average			227
1971	240	16	256
1972	261	24	285
1973	212	0	212
1974	220	62	282
1975	260	40	300
1976	130	40	170
1977	175	157	332
1978	265	5	270
1979	139	52	191
1980	-	0	0
1981	-	0	0
1982	-	0	0
1983	-	0	0
1984	-	83	83
1985	-	675	675
1986	-	721	721
1987	-	471	471
1988	-	256	256
1989	-	158	158
1990	-	109	109
1991	-	4	4
1992	-	91	91
1993	-	0	0
1994	-	0	0
1995	-	0	0
1996	-	0	0
1997	-	0	0
1998	-	0	0
1999	-	0	0
2000	-	0	0
2001	-	0	0
2002	-	-	0
2003	-	-	0
2004	-	-	0
2005	-	-	0

Column (4) = Column (2) + Column (3).

FOR YEARS PRECEDING 1971: Refer to Volume 5, August 1976, Page I-60.

Base Period Average calculated from Base Period Volume 5, table 20, page 443

TABLE NO. 20

RIVERSIDE HIGHLAND WATER COMPANY WATER PRODUCTION
FROM COLTON BASIN
 (Quantities in Acre Feet)

Year	R H # 4 1S4W28K01S 3601525	R H # 4A 1S4W28K02S 3602182	Total Production in Colton Basin
(1)	(2)	(3)	(4)
Base Period Average			227
2006	-	-	0
2007	-	-	0
2008	-	-	0
2009	-	-	0
2010	-	-	0
2011	-	-	0
2012	-	-	0
2013	-	-	0
2014	-	-	0
2015	-	-	0
2016	-	-	0
2017	-	-	0
2018	-	-	0
2019	-	-	0
2020	-	-	0
2021	-	-	0
2022	-	-	0
2023	-	-	0
2024	-	-	0
2025	-	-	0
2026	-	-	0
2027	-	-	0
2028	-	-	0
2029	-	-	0
2030	-	-	0
2031	-	-	0
2032	-	-	0
2033	-	-	0
2034	-	-	0
2035	-	-	0
2036	-	-	0
2037	-	-	0
2038	-	-	0
2039	-	-	0
2040	-	-	0

Column (4) = Column (2) + Column (3).

FOR YEARS PRECEDING 1971: Refer to Volume 5, August 1976, Page I-60.

Base Period Average calculated from Base Period Volume 5, table 20, page 443

TABLE NO. 21

RIVERSIDE HIGHLAND WATER COMPANY WATER PRODUCTION
 FROM RIVERSIDE BASIN IN SAN BERNARDINO & RIVERSIDE COUNTIES

(Quantities in Acre Feet)

Riverside North Basin

Year	Riverside North Basin										Reassigned Production from RN to RS	Total Water Production in Riverside Basin in San Bernardino County	Riverside South Basin		Total Water Production in Riverside Basin in Riverside County	
	°R N #3 1S4W28L01S 3601524	R N #6 2S4W06R01S 3601525	R N #6 2S4W05F03S	R N #7 2S4W06R01S	°R N #16 1S4W33B05S	R N #17 1S4W28N05S	R N #20 1S4W28L02S	L V #1 1S4W32M01S	L V #2 1S4W32M	L V #3 1S4W23M04S			Production in San Bernardino County	R H #21 2S4W08M01S	R.H. #22 2S4W08M02S	Production in Riverside County
(1)	(2)	(2a)	(2b)	(3)	(4)	(5)	(6)	(7)	(8)	(9)	(9a)	(10)	(11)	(12)	(15)	
Base Period Average												3,752			555	
1971	-			1,901	-	2,734	669	0	0			5,304	642	1,456	2,098	
1972	-			1,572	-	1,868	789	0	0			4,229	272	1,096	1,368	
1973	-			1,339	-	1,903	832	0	0			4,074	236	1,034	1,270	
1974	-			1,255	-	1,283	833	0	0			3,371	480	1,053	1,533	
1975	-			1,340	-	871	805	0	0			3,016	94	1,133	1,227	
1976	-			1,284	-	1,469	839	0	0			3,592	137	1,183	1,320	
1977	-			1,693	-	2,343	663	0	0			4,699	219	869	1,088	
1978	-			1,460	-	1,629	834	0	0			3,923	683	613	1,296	
1979	-			1,513	-	1,488	875	0	0			3,876	172	803	975	
1980	-			1,356	-	1,926	732	270	0			4,284	590	410	1,000	
1981	-			1,543	-	2,200	789	411	22			4,965	607	665	1,272	
1982	-			760	-	1,679	485	364	42			3,330	700	453	1,153	
1983	-			539	-	1,299	604	94	0			2,536	1,031	2	1,033	
1984	-			1,101	-	2,498	897	49	0			4,545	1,910	682	2,592	
1985	-			1,174	-	2,198	816	287	0			4,475	1,120	797	1,917	
1986	-			875	-	175	890	149	0			2,089	1,175	842	2,017	
1987	-			945	-	91	565	31	0			1,632	996	817	1,813	
1988	-			1,031	-	0	624	130	0			1,785	775	750	1,525	
1989	-			830	-	0	768	95	0	865		2,558	1,072	357	1,429	
1990	-			757	-	1	728	55	0	1,317		2,858	1,138	408	1,546	
1991	-			1,011	-	2	784	80	0	1,704		3,581	1,023	465	1,488	
1992	-			1,116	-	65	767	-	-	267		2,215	460	385	845	
1993	-			1,237	-	616	619	-	-	562		3,034	585	250	835	
1994	-			1,466	-	1,643	110	-	-	66		3,285	372	243	615	
1995	-			1,376	-	780	311	-	-	659		3,126	262	349	611	
1996	-			1,434	-	232	528	-	-	202		2,396	280	278	558	
1997	-			1,431	-	430	471	-	-	181		2,513	126	324	450	
1998	-			1,168	-	248	609	-	-	170		2,195	138	188	326	
1999	-			1,527	-	625	354	-	-	121		2,627	463	20	483	
2000	-			1,086	-	598	332	-	-	209	1,087	1,138	1)	63	24	1,174
2001	-		51	757	-	201	309	-	-	60	37	1,341	2)	527	129	693
2002	-		948	1,170	-	16	379	-	-	64	0	2,577	771	47	818	
2003	-		481	945	-	127	324	-	-	8	0	1,885	451	33	484	
2004	-		313	972	-	448	1,011	-	-	49	0	2,793	244	64	308	
2005	-		294	962	-	100	723	-	-	11	59	2,031	572	59	690	

FOR YEARS PRECEDING 1971: Refer to Volume 5, August 1976, Page I-62.

° Abandoned &/or Filed Closed.

Column (10) = Sum of Columns (2) thru Column (9) minus (9a) after 2000

Column (15) = Column (11) + Column (12), plus (9a) after 2000

1) For 2000, 1,087 AF of Riverside North production assigned to Riverside South Basin to accommodate changes in operations to bypass "commingling" calculation to better represent actual deliveries.

2) For 2001, 37 AF of Riverside North production assigned to Riverside South Basin to accommodate changes in operations to bypass "commingling" calculation to better represent actual deliveries.

TABLE NO. 21

RIVERSIDE HIGHLAND WATER COMPANY WATER PRODUCTION
FROM RIVERSIDE BASIN IN SAN BERNARDINO & RIVERSIDE COUNTIES
 (Quantities in Acre Feet)

Year	Riverside North Basin										Reassigned Production from RN to RS	Total Water Production in Riverside Basin in San Bernardino County	Riverside South Basin		Total Water Production in Riverside Basin in Riverside County
	°R N #3 1S4W28L01S 3601524	R N #6 2S4W06R01S 3601525	R N #6 2S4W05F03S 3603738	R N #7 2S4W06R01S 3601526	°R N #16 1S4W33B05S 3601531	R N #17 1S4W28N05S 3601532	R N #20 1S4W28L02S 3601534	L V #1 1S4W32M01S 3601789	L V #2 1S4W32M 3601790	L V #3 1S4W23M04S 3603139		(9a)	(10)	R H #21 2S4W08M01S 3301655	R.H. #22 2S4W08M02S 3301656
(1)	(2)	(2a)	(2b)	(3)	(4)	(5)	(6)	(7)	(8)	(9)	(9a)	(10)	(11)	(12)	(15)
Base Period Average												3,752			555
2006	-		727	243	-	42	251	-	-	2	66	1,199	50	46	162
2007	-		1,708	326	-	12	140	-	-	13	63	2,136	0	25	88
2008	-		1,352	154	-	40	95	-	-	4	62	1,583	0	0	62
2009	-		2,075	546	-	48	0	-	-	37	89	2,617	0	0	89
2010	-		1,637	1,253	-	71	1	-	-	25	78	2,909	0	0	78
2011	-		1,099	1,129	-	8	0	-	-	277	74	2,439	0	0	74
2012	-		1,461	699	-	19	0	-	-	180	88	2,271	0	0	88
2013	-				-			-	-						
2014	-				-			-	-						
2015	-				-			-	-						
2016	-				-			-	-						
2017	-				-			-	-						
2018	-				-			-	-						
2019	-				-			-	-						
2020	-				-			-	-						
2021	-				-			-	-						
2022	-				-			-	-						
2023	-				-			-	-						
2024	-				-			-	-						
2025	-				-			-	-						
2026	-				-			-	-						
2027	-				-			-	-						
2028	-				-			-	-						
2029	-				-			-	-						
2030	-				-			-	-						
2031	-				-			-	-						
2032	-				-			-	-						
2033	-				-			-	-						
2034	-				-			-	-						
2035	-				-			-	-						
2036	-				-			-	-						
2037	-				-			-	-						
2038	-				-			-	-						
2039	-				-			-	-						
2040	-				-			-	-						

FOR YEARS PRECEDING 1971: Refer to Volume 5, August 1976, Page I-62.
 ° Abandoned &/or Filed Closed.

Column (10) = Sum of Columns (2) thru Column (9) minus (9a) after 2000
 Column (15) = Column (11) + Column (12), plus (9a) after 2000

(9a) Riverside North production assigned to Riverside South Basin to accommodate changes in operations to bypass "commingling" calculation to better represent actual deliveries.

TABLE NO. 22

RIVERSIDE HIGHLAND WATER COMPANY
 WATER SUPPLY FROM OTHER COMPANIES
 AND RIVERSIDE HIGHLAND CO. PRODUCTION
 (Quantities in Acre Feet)

Year	Companies Supplying Additional Water			San Bernardino Basin	San Bernardino Basin less Colton		Riverside Basin		Total Production	Grand Total Water Supply
	City of Riverside	Net water from others	Total Supply		Basin less HGMP & Wtr Stock	Colton Basin	San Bernardino County	Riverside County		
(1)	(2)	(3)	(4)	(5)	(5a)	(6)	(7)	(8)	(9)	(10)
1971	0	0	0	4,012		256	5,304	2,098	11,670	11,670
1972	0	0	0	4,532		285	4,229	1,368	10,414	10,414
1973	0	0	0	3,512		212	4,074	1,270	9,068	9,068
1974	279	0	279	4,088		282	3,371	1,533	9,274	9,553
1975	0	0	0	4,709		300	3,016	1,227	9,252	9,252
1976	0	0	0	4,520		170	3,592	1,320	9,602	9,602
1977	0	0	0	3,583		332	4,699	1,088	9,702	9,702
1978	0	0	0	1,350		270	3,923	1,296	6,839	6,839
1979	0	0	0	3,369		191	3,876	975	8,411	8,411
1980	0	0	0	3,677		0	4,284	1,000	8,961	8,961
1981	0	0	0	3,604		0	4,965	1,272	9,841	9,841
1982	0	0	0	2,795		0	3,330	1,153	7,278	7,278
1983	0	0	0	3,162		0	2,536	1,033	6,731	6,731
1984	0	0	0	4,759		83	4,545	2,592	11,979	11,979
1985	0	0	0	3,312		675	4,475	1,917	10,379	10,379
1986	0	0	0	4,744		721	2,089	2,017	9,571	9,571
1987	0	0	0	3,919		471	1,632	1,813	7,835	7,835
1988	0	0	0	4,775		256	1,785	1,525	8,341	8,341
1989	0	0	0	4,681		158	2,558	1,429	8,826	8,826
1990	0	0	0	4,092		109	2,858	1,546	8,605	8,605
1991	0	0	0	3,021		4	3,581	1,488	8,094	8,094
1992	0	72	72	4,052		91	2,215	845	7,203	7,275
1993	0	575	575	3,241		0	3,034	835	7,110	7,685
1994	0	0	0	4,324		0	3,285	615	8,224	8,224
1995	0	0	0	3,955		0	3,126	611	7,692	7,692
1996	0	0	0	5,051		0	2,396	558	8,005	8,005
1997	0	0	0	4,939		0	2,513	450	7,902	7,902
1998	0	0	0	3,250		0	2,195	326	5,771	5,771
1999	0	-2,041	-2,041	4,972	2,931	0	2,627	483	8,082	6,041
2000	0	-567	-567	3,423	2,856	0	1,138	1,174	5,735	5,168
2001	0	-260	-260	2,925	2,665	0	1,341	693	4,959	4,699
2002	0	-1,910	-1,910	4,309	2,399	0	2,577	818	7,704	5,794
2003	-1,618	-3	-1,621	3,881	2,260	0	1,885	484	6,250	4,629
2004	-297	0	-297	1,754	1,457	0	2,793	308	4,855	4,558
2005	-1,682	0	-1,682	3,378	1,696	0	2,031	690	6,099	4,417

Column (2) = From City of Riverside Table 3, Column (1)
 Column (3) = From Riverside Highland Co. records
 Column (4) = Column (2) + Column (3)

Column (5) = From Table 19, Column (16).
 Column (6) = From Table 20, Column (4).
 Column (7) = From Table 21, Column (10).

Column (8) = From Table 21, Column (15).
 Column (9) = Columns (5) + (6) + (7) + (8).
 Column (10) = Column (4) + Column (9).

1999 2,041 AF was pumped for SBVWMD Pilot Dewatering Program (HGMP)
 2000 567 AF was pumped for SBVWMD Pilot Dewatering Program (HGMP)

2001 260 AF was pumped for SBVWMD Pilot Dewatering Program (HGMP) from FW #2, #5 & #18
 2002 1,909 AF was pumped for SBVWMD Pilot Dewatering Program (HGMP) from FW #2, #5 & #18
 2003 3 AF was pumped for SBVWMD Pilot Dewatering Program (HGMP) from FW #2, #5 & #18

FOR YEARS PRECEDING 1971: Refer to Volume 5, August 1976, Page I-64.

TABLE NO. 22

RIVERSIDE HIGHLAND WATER COMPANY
 WATER SUPPLY FROM OTHER COMPANIES
 AND RIVERSIDE HIGHLAND CO. PRODUCTION
 (Quantities in Acre Feet)

Year	Companies Supplying Additional Water			San Bernardino Basin	San Bernardino Basin less HGMP & Wtr Stock	Colton Basin	Riverside Basin		Total Production	Grand Total Water Supply
	City of Riverside	Net water from others	Total Supply				San Bernardino Basin	San Bernardino County		
(1)	(2)	(3)	(4)	(5)	(5a)	(6)	(7)	(8)	(9)	(10)
2006	-1,661	0	-1,661	4,149	2,488	0	1,199	162	5,510	3,849
2007	-1,640	0	-1,640	3,633	1,993	0	2,136	88	5,857	4,217
2008	-440	0	-440	2,730	2,290	0	1,583	62	4,375	3,935
2009	-440	0	-440	1,648	1,208	0	2,617	89	4,354	3,914
2010	-440	0	-440	1,136	696	0	2,909	78	4,123	3,683
2011	-440	0	-440	1,655	1,215	0	2,439	74	4,168	3,728
2012	-440	0	-440	2,135	1,695	0	2,271	88	4,494	4,054
2013										
2014										
2015										
2016										
2017										
2018										
2019										
2020										
2021										
2022										
2023										
2024										
2025										
2026										
2027										
2028										
2029										
2030										
2031										
2032										
2033										
2034										
2035										
2036										
2037										
2038										
2039										
2040										

Column (2) = From City of Riverside Table 1, Line 69K

Column (5) = From Table 19, Column (16).

Column (8) = From Table 21, Column (15).

Starting in 2008, this is Riverside lease from Riverside Highland

Column (6) = From Table 20, Column (4).

Column (9) = Columns (5) + (6) + (7) + (8).

Column (3) = From Riverside Highland Co. records

Column (7) = From Table 21, Column (10).

Column (10) = Column (4) + Column (9).

Column (4) = Column (2) + Column (3)

FOR YEARS PRECEDING 1971: Refer to Volume 5, August 1976, Page I-64.

The following Tables are not needed
after the Base Period Verification Work

Riverside Highland Water Company

Table Numbered 23, 24, 25, 26, 27

see Volume 5-1974 for data

TABLE NO. 23R

RIVERSIDE HIGHLAND WATER COMPANY
DISTRIBUTION OF EXTRACTION
 (Quantities in Acre Feet)

Year	San Bernardino Basin Area	Colton Basin	Riverside North Basin	Total S.B. Co. Production	Riverside South Basin	Riverside Total Production	Distribution of Production			Water Delivered		
	Production	Production	Production	Production	Production	Production	% S.B. Basin Area	% Colton Basin	% Riverside North Basin	in S.B. Co.	in Riv. Co.	Total Delivered
(1)	(2)	(3)	(4)	(5)	(6)	(7)	(8)	(9)	(10)	(11)	(12)	(13)
1985	3,312	675	4,475	8,462	1,917	10,379	39%	8%	53%	3,043	3,405	6,448
1986	4,744	721	2,089	7,554	2,017	9,571	63%	10%	28%	2,965	3,292	6,257
1987	3,919	471	1,632	6,022	1,813	7,835	65%	8%	27%	2,777	2,918	5,695
1988	4,775	256	1,785	6,816	1,525	8,341	70%	4%	26%	2,736	3,430	6,166
1989	4,681	158	2,558	7,397	1,429	8,826	63%	2%	35%	2,938	3,536	6,474
1990	4,092	109	2,858	7,059	1,546	8,605	58%	2%	40%	3,111	3,597	6,708
1991	3,021	4	3,581	6,606	1,488	8,094	46%	0%	54%	2,756	3,357	6,113
1992	4,052	91	2,215	6,358	845	7,203	64%	1%	35%	2,799	2,849	5,648
1993	3,241	0	3,034	6,275	835	7,110	52%	0%	48%	2,921	3,114	6,035
1994	4,324	0	3,285	7,609	615	8,224	57%	0%	43%	3,030	3,403	6,433
1995	3,955	0	3,126	7,081	611	7,692	56%	0%	44%	3,073	3,078	6,151
1996	5,051	0	2,396	7,447	558	8,005	68%	0%	32%	3,237	3,139	6,376
1997	4,939	0	2,513	7,452	450	7,902	66%	0%	34%	3,241	3,149	6,390
1998	3,250	0	2,195	5,445	326	5,771	60%	0%	40%	2,810	2,127	4,937
1999	2,931	0	2,627	5,558	483	6,041	53%	0%	47%	3,375	1,789	5,164
2000	2,856	0	1,138	3,994	1,174	5,168	72%	0%	28%	3,492	1,098	4,590
2001	2,665	0	1,341	4,006	693	4,699	67%	0%	33%	3,362	770	4,132
2002	2,399	-	2,577	4,976	818	5,794	48%	-	52%	4,340	998	5,338
2003	2,260	-	1,885	4,145	484	4,629	55%	-	45%	3,537	848	4,385
2004	1,457	-	2,793	4,250	308	4,558	34%	-	66%	3,516	698	4,214
2005	1,696	-	2,031	3,727	690	4,417	46%	-	54%	3,236	1,007	4,243

Columns (2) (3) (4) (6) from Table No. 22.

Column (5) = Column (2) + (3) + (4).

Column (7) = Columns (5) + Column (6).

1985-1989 shown for information only, new format starts with 1990 report.

Replaces Tables 28 thru 31 starting with 1990.

Column (2) excludes High Groundwater Mitigation production and Riverside Stock water leases

Column (8) = Column (2) ÷ Column (5).

Column (9) = Column (3) ÷ Column (5).

Column (10) = Column (4) ÷ Column (5).

Columns (11) & (12) from RH Co. records.

Column (13) = Columns (11) + Column (12).

TABLE NO. 23R

RIVERSIDE HIGHLAND WATER COMPANY
DISTRIBUTION OF EXTRACTION
 (Quantities in Acre Feet)

Year	San Bernardino Basin Area Production	Colton Basin Production	Riverside North Basin Production	Total S.B. Co. Production	Riverside South Basin Production	Total Production	Distribution of Production			Water Delivered		
							% S.B. Basin Area	% Colton Basin	% Riverside North Basin	in S.B. Co.	in Riv. Co.	Total Delivered
(1)	(2)	(3)	(4)	(5)	(6)	(7)	(8)	(9)	(10)	(11)	(12)	(13)
2006	2,488	-	1,199	3,687	162	3,849	67%	-	33%	3,415	434	3,849
2007	1,993	-	2,136	4,129	88	4,217	48%	-	52%	3,597	534	4,131
2008	2,290	-	1,583	3,873	62	3,935	59%	-	41%	3,441	456	3,897
2009	1,208	-	2,617	3,825	89	3,914	32%	-	68%	3,254	494	3,748
2010	696	-	2,909	3,605	78	3,683	19%	-	81%	3,035	397	3,432
2011	1,215	-	2,439	3,654	74	3,728	33%	-	67%	2,973	418	3,391
2012	1,695	-	2,271	3,966	88	4,054	43%	-	57%	3,482	480	3,962
2013		-										
2014		-										
2015		-										
2016		-										
2017		-										
2018		-										
2019		-										
2020		-										
2021		-										
2022		-										
2023		-										
2024		-										
2025		-										
2026		-										
2027		-										
2028		-										
2029		-										
2030		-										
2031		-										
2032		-										
2033		-										
2034		-										
2035		-										
2036		-										
2037		-										
2038		-										
2039		-										
2040		-										

Columns (2) (3) (4) (6) from Table No. 22.

Column (5) = Column (2) + (3) + (4).

Column (6) from Table No. 21 , Column (15)

Column (7) = Columns (5) + Column (6).

Column (8) = Column (2) ÷ Column (5).

Column (9) = Column (3) ÷ Column (5).

Column (10) = Column (4) ÷ Column (5).

Columns (11) & (12) from RH Co. records.

Column (13) = Columns (11) + Column (12).

Column (2) excludes High Groundwater Mitigation production and Riverside Stock water leases

data from RH Condensed Water Summary Report

TABLE NO. 23R

RIVERSIDE HIGHLAND WATER COMPANY
DISTRIBUTION OF EXTRACTION
 (Quantities in Acre Feet)

Year	Production + Delivered	Adjusted Demand			Adjusted Demand			Adjusted Demand			
		Adjusted S. B. Co. Delivery	Adjusted Riv. Co. Delivery	Total Production	San Bernardino Basin Area Production			Colton Basin		Riverside North Basin	
		(3)	(4)	(4a)	Delivered to S.B. Basin	Delivered to Colton/Riv N	Delivered Outside Valley	Delivered to Colton/Riv N	Delivered Outside Valley	Delivered to Colton/Riv N	Delivered Outside Valley
(1)	(2)	(3)	(4)	(4a)	(5)	(6)	(7)	(8)	(9)	(10)	(11)
1985	1.6096	4,898	5,481	10,379	-	1,917	1,395	391	284	2,590	1,885
1986	1.5296	4,535	5,036	9,571	-	2,848	1,896	433	288	1,254	835
1987	1.3758	3,821	4,014	7,835	-	2,486	1,433	299	172	1,035	597
1988	1.3527	3,701	4,640	8,341	-	2,593	2,182	139	117	969	816
1989	1.3633	4,005	4,821	8,826	-	2,535	2,146	86	72	1,385	1,173
1990	1.2828	3,991	4,614	8,605	-	2,313	1,779	62	47	1,616	1,242
1991	1.3241	3,649	4,445	8,094	-	1,669	1,352	2	2	1,978	1,603
1992	1.2753	3,570	3,633	7,203	-	2,275	1,777	51	40	1,244	971
1993	1.1781	3,441	3,669	7,110	-	1,777	1,464	0	0	1,664	1,370
1994	1.2784	3,874	4,350	8,224	-	2,201	2,123	0	0	1,672	1,613
1995	1.2505	3,843	3,849	7,692	-	2,146	1,809	0	0	1,696	1,430
1996	1.2555	4,064	3,941	8,005	-	2,756	2,295	0	0	1,308	1,088
1997	1.2366	4,008	3,894	7,902	-	2,656	2,283	0	0	1,352	1,161
1998	1.1689	3,285	2,486	5,771	-	1,961	1,289	0	0	1,324	871
1999	1.1698	3,948	2,093	6,041	-	2,082	849	0	0	1,866	761
2000	1.1259	3,932	1,236	5,168	-	2,811	45	0	0	1,120	18
2001	1.1372	3,823	876	4,699	-	2,543	122	0	0	1,280	61
2002	1.0854	4,711	1,083	5,794	-	2,271	128	-	-	2,440	137
2003	1.0556	3,734	895	4,629	-	2,036	224	-	-	1,698	187
2004	1.0816	3,803	755	4,558	-	1,304	153	-	-	2,499	294
2005	1.0410	3,369	1,048	4,417	-	1,533	163	-	-	1,836	195

Column (2) = Column (7) ÷ Column (13) on previous page. Column (7) = Column (2) previous page - [Column (3) x Column (8) from previous page].
 Column (3) = Column (11) on previous page x Column (2). Column (8) = Column (3) previous page - Column (9).
 Column (4) = Column (12) on previous page x Column (2). Column (9) = Column (3) previous page - [Column (3) x Column (9) from previous page].
 Column (5) = Company method of operation. Column (10) = Column (4) previous page - Column (11).
 Column (6) = Column (2) previous page - Column (7). Column (11) = Column (4) previous page - [Column (3) x Column (10) from previous page].
 1985-1989 shown for information only, new format starts with 1990 report.

Replaces Tables 28 thru 31 starting with 1990.

TABLE NO. 23R

RIVERSIDE HIGHLAND WATER COMPANY
DISTRIBUTION OF EXTRACTION
 (Quantities in Acre Feet)

Year	Production ÷ Delivered %	Adjusted Demand		Total Production	San Bernardino Basin Area Production			Adjusted Demand		Adjusted Demand	
		S. B. Co. Delivery	Riv. Co. Delivery		Delivered to S.B. Basin	Delivered to Colton/Riv N	Delivered Outside Valley	Delivered to Colton/Riv N	Delivered Outside Valley	Delivered to Colton/Riv N	Delivered Outside Valley
(1)	(2)	(3)	(4)	(4a)	(5)	(6)	(7)	(8)	(9)	(10)	(11)
2006	1.0001	3,415	434	3,849	-	2,304	184	-	-	1,111	88
2007	1.0208	3,672	545	4,217	-	1,772	221	-	-	1,900	236
2008	1.0098	3,475	460	3,935	-	2,054	236	-	-	1,420	163
2009	1.0443	3,398	516	3,914	-	1,073	135	-	-	2,325	292
2010	1.0731	3,257	426	3,683	-	629	67	-	-	2,628	281
2011	1.0994	3,268	460	3,728	-	1,087	128	-	-	2,182	257
2012	1.0232	3,563	491	4,054	-	1,523	172	-	-	2,040	231
2013											
2014											
2015											
2016											
2017											
2018											
2019											
2020											
2021											
2022											
2023											
2024											
2025											
2026											
2027											
2028											
2029											
2030											
2031											
2032											
2033											
2034											
2035											
2036											
2037											
2038											
2039											
2040											

Column (2) = Column (7) ÷ Column (13) on previous page.
 Column (3) = Column (11) on previous page x Column (2).
 Column (4) = Column (12) on previous page x Column (2).
 Column (5) = Company method of operation.
 Column (6) = Column (2) previous page - Column (7).

Column (7) = Column (2) previous page - [Column (3) x Column (8) from previous page].
 Column (8) = Column (3) previous page - Column (9).
 Column (9) = Column (3) previous page - [Column (3) x Column (9) from previous page].
 Column (10) = Column (4) previous page - Column (11).
 Column (11) = Column (4) previous page - [Column (3) x Column (10) from previous page].

TABLE NO. 28

RIVERSIDE HIGHLAND WATER COMPANY
IRRIGATION AND DOMESTIC DELIVERIES AND PRODUCTION
REQUIRED IN RIVERSIDE & SAN BERNARDINO COUNTIES

Year	Total Water		Deliveries in M.I.D.				Production in		Riverside Co. Historic Delivery					San Bernardino		
	Produced in MID	Domestic	Irrigation	Total Dom & Irr	Unaccounted for		Required in M.I.D.		& Required Production					Required Production		
(1)	(2)	(3)	(4)	(5)	Total	%	Irrigation	Domestic	Del.	Prod.	Del.	Prod.	Total Production	Irrigation	Domestic	Total
(1)	(2)	(3)	(4)	(5)	(6)	(7)	(8)	(9)	(10)	(11)	(12)	(13)	(14)	(15)	(16)	(17)
1971	294,107	44,029	208,260	252,289	41,818	14.22%	242,780	51,327	160,989	187,674	1,317	1,535	189,209	55,106	49,792	104,898
1972	262,453	43,737	183,269	227,006	35,447	13.51%	211,886	50,567	142,980	165,306	2,074	2,398	167,704	46,580	48,169	94,749
1973	228,494	39,865	157,982	197,847	30,647	13.41%	182,454	46,040	127,170	146,869	1,211	1,399	148,268	35,585	44,641	80,226
1974	240,733	43,375	168,048	211,423	29,310	12.18%	191,345	49,388	134,160	152,759	1,295	1,474	154,233	38,586	47,914	86,500
1975	233,140	41,641	162,050	203,691	29,449	12.63%	185,479	47,661	130,714	149,610	1,242	1,422	151,032	35,866	46,239	82,105
1976	241,910	43,263	170,027	213,290	28,620	11.83%	192,842	49,068	138,206	156,749	1,241	1,407	158,156	36,091	47,661	83,752
1977	244,510	41,580	175,362	216,942	27,568	11.27%	197,646	46,864	142,848	160,992	1,237	1,394	162,386	36,644	45,467	82,111
1978	172,318	44,491	110,302	154,793	17,525	10.17%	122,790	49,528	94,077	104,728	1,600	1,781	106,509	18,062	47,747	65,809
1979	211,969	49,024	128,539	177,563	34,406	16.23%	153,446	58,523	109,106	130,247	1,745	2,083	132,330	23,199	56,440	79,639
1980	225,892	51,948	130,037	181,985	43,907	19.44%	161,411	64,481	108,677	134,897	2,089	2,593	137,490	26,514	61,888	88,402
1981	249,099	57,199	142,376	199,575	49,524	19.88%	177,706	71,393	119,741	149,454	2,254	2,938	152,392	28,252	68,455	96,707
1982	183,419	54,277	96,872	151,149	32,270	17.59% *	123,715	59,704	82,196	104,972	2,024	2,226	107,198	18,742	57,478	76,220
1983	169,623	67,702	60,009	127,711	41,912	24.71% *	95,151	74,472	54,155	85,874	2,440	2,684	88,558	9,277	71,788	81,065
1984	301,971	75,971	112,549	188,520	113,451	37.57% *	218,304	83,667	100,795	195,513	2,409	2,650	198,163	22,791	81,017	103,808
1985	261,587	69,508	93,043	162,551	99,036	37.86% **	178,178	83,409	83,352	159,612	2,486	2,983	162,595	18,566	80,426	98,992
1986	241,156	72,147	85,598	157,745	83,411	34.59% °	150,972	90,184	80,048	141,189	2,943	3,679	144,868	9,783	86,505	96,288
1987	197,512	69,232	74,309	143,541	53,971	27.33% *	117,895	79,617	70,566	111,957	2,980	3,427	115,384	5,938	76,190	82,128
1988	210,259	70,318	85,115	155,433	54,826	26.08% *	129,393	80,866	82,600	125,570	3,860	4,439	130,009	3,823	76,427	80,250
1989	222,442	79,141	84,048	163,189	59,253	26.64% °°	124,307	98,135	81,365	120,339	7,764	9,627	129,966	3,968	88,507	92,475

Replaced by Table 23R starting with 1990.

Columns (2), (3), (4), (5), (6), (10) & (12) are from Company Records, "Condensed Water Summary".

Column (2) Includes water delivered by other companies.

Columns (7) (8) (9) See Notes.

Columns (11), (13), (15), (16) See Worksheets.

Column (14) = Column (11) + Column (13).

Column (17) = Column (15) + Column (16).

* Assumed domestic loss at 15% with Column (7) as total system loss.

** Assumed domestic loss at 20% with Column (7) as total system loss, known loss in L.C. Line of 868 af.

° Assumed domestic loss at 25% with Column (7) as total system loss.

°° Assumed domestic loss at 24% with Column (7) as total system loss.

FOR YEARS PRECEDING 1971: Refer to Volume 5, August 1976, Page I-73.

TABLE NO. 29

RIVERSIDE HIGHLAND WATER COMPANY
 WATER PRODUCTION SHOWN ON RECORDATION FILINGS
 DELIVERED FOR IRRIGATION AND DOMESTIC USES WITHIN BOTH RIVERSIDE AND SAN BERNARDINO COUNTIES

REQUIRED PRODUCTION FOR DELIVERIES MADE IN SAN BERNARDINO & RIVERSIDE COUNTIES

WATER PRODUCTION FOR
 RIVERSIDE & SAN BERNARDINO CO.

TOTAL
 PRODUCTION IN
 RIVERSIDE &
 SAN BERNARDINO
 COUNTIES

YEAR	----- Riverside County -----												----- San Bernardino County -----						TOTAL PRODUCTION IN RIVERSIDE & SAN BERNARDINO COUNTIES				
	Production Required for Deliveries				Total Filed Extractions A.F.	Ratio of Filed to Production Required	Irrigation			Domestic			Irrigation			Domestic			Riverside Co.		San Bernardino Co.		A.F.
	Irrig. M.I.D.	Dom. M.I.D.	Total M.I.D.	A.F.			M.I.D.	A.F.	% Total Production	M.I.D.	A.F.	% Total Prod.	M.I.D.	A.F.	% Total Prod.	M.I.D.	A.F.	% Total Prod.	Irrig. A.F.	Dom. A.F.	Irrig. A.F.	Dom. A.F.	
(1)	(2)	(3)	(4)	(5)	(6)	(7)	(8)	(9)	(10)	(11)	(12)	(13)	(14)	(15)	(16)	(17)	(18)	(19)	(20)	(21)	(22)	(23)	
1971	242,780	51,327	294,107	11,667	11,670	100.03%	187,674	7,445	63.81%	1,535	61	0.52%	55,106	2,186	18.74%	49,792	1,975	16.93%	7,447	61	2,187	1,975	11,670
1972	211,886	50,567	262,453	10,411	10,414	100.03%	165,306	6,558	62.98%	2,398	95	0.91%	46,580	1,848	17.75%	48,169	1,911	18.35%	6,559	95	1,848	1,911	10,414
1973	182,454	46,040	228,494	9,064	9,068	100.04%	146,869	5,826	64.28%	1,399	55	0.61%	35,585	1,412	15.57%	44,641	1,771	19.53%	5,829	56	1,412	1,771	9,068
1974	191,345	49,388	240,733	9,550	9,553	100.03%	152,759	6,060	63.46%	1,474	58	0.61%	38,586	1,531	16.03%	47,914	1,900	19.90%	6,062	58	1,531	1,901	9,553
1975	185,479	47,661	233,140	9,249	9,252	100.04%	149,610	5,935	64.17%	1,422	56	0.61%	35,866	1,423	15.38%	46,239	1,834	19.83%	5,937	56	1,423	1,835	9,252
1976	192,842	49,068	241,910	9,596	9,602	100.06%	156,749	6,218	64.80%	1,407	56	0.58%	36,091	1,432	14.92%	47,661	1,890	19.70%	6,222	56	1,433	1,892	9,602
1977	197,646	46,864	244,510	9,700	9,702	100.03%	160,992	6,386	65.84%	1,394	55	0.57%	36,644	1,454	14.99%	45,467	1,803	18.59%	6,388	55	1,454	1,804	9,701
1978	122,790	49,528	172,318	6,836	6,839	100.05%	104,728	4,154	60.78%	1,781	71	1.03%	18,062	717	10.48%	47,747	1,894	27.70%	4,156	71	717	1,895	6,839
1979	153,446	58,523	211,969	8,409	8,411	100.03%	130,247	5,167	61.45%	2,083	83	0.98%	23,199	920	10.94%	56,440	2,239	26.62%	5,168	83	921	2,239	8,411
1980	161,411	64,481	225,892	8,961	8,961	100.00%	134,897	5,351	59.72%	2,593	103	1.15%	26,514	1,052	11.74%	61,888	2,455	27.39%	5,351	103	1,052	2,455	8,961
1981	177,706	71,393	249,099	9,882	9,841	99.59%	149,454	5,929	60.00%	2,938	117	1.18%	28,252	1,121	11.34%	68,455	2,715	27.48%	5,904	116	1,116	2,704	9,841
1982	123,715	59,704	183,419	7,276	7,278	100.03%	104,972	4,164	57.23%	2,226	88	1.21%	18,742	743	10.22%	57,478	2,280	31.33%	4,165	88	744	2,280	7,278
1983	95,151	74,472	169,623	6,729	6,731	100.03%	85,874	3,407	50.63%	2,684	106	1.58%	9,277	368	5.47%	71,788	2,847	42.32%	3,408	107	368	2,848	6,731
1984	218,304	83,667	301,971	11,979	11,979	100.00%	195,513	7,756	64.75%	2,650	105	0.88%	22,791	904	7.55%	81,017	3,213	26.83%	7,756	105	904	3,213	11,979
1985	178,178	83,409	261,587	10,377	10,379	100.02%	159,612	6,332	61.02%	2,983	118	1.14%	18,566	737	7.10%	80,426	3,190	30.74%	6,333	118	737	3,191	10,379
1986	150,972	90,184	241,156	9,567	9,571	100.05%	141,189	5,601	58.55%	3,679	146	1.53%	9,783	388	4.06%	86,505	3,431	35.87%	5,604	146	388	3,433	9,571
1987	117,895	79,617	197,512	7,835	7,835	100.00%	111,957	4,441	56.68%	3,427	136	1.74%	5,938	236	3.01%	76,190	3,022	38.57%	4,441	136	236	3,022	7,835
1988	129,393	80,866	210,259	8,341	8,341	100.00%	125,570	4,981	59.72%	4,439	176	2.11%	3,823	152	1.82%	76,427	3,031	36.34%	4,981	176	152	3,031	8,341
1989	124,307	98,135	222,442	8,824	8,826	100.02%	120,339	4,774	54.10%	9,627	382	4.33%	3,968	157	1.78%	88,507	3,511	39.78%	4,775	382	157	3,511	8,825

Replaced by Table 23R starting with 1990.

Column (1) = From Column (8), Table No. 28.
 Column (2) = From Column (9), Table No. 28.
 Column (3) = From Column (2), Table No. 28.
 Column (4) = Column (3) * 0.0396694.
 Column (5) = From Column (10), Table No. 22.
 Column (6) = From Column (5) + Column (4).
 Column (7) = From Column (11), Table No. 28.

Column (8) = Column (7) * 0.0396694.
 Column (9) = Column (8) + Column (4).
 Column (10) = From Column (13), Table No. 28.
 Column (11) = Column (10) * 0.0396694.
 Column (12) = Column (11) + Column (4).
 Column (13) = From Column (15), Table No. 28.
 Column (14) = Column (13) * 0.0396694.

Column (15) = Column (14) + Column (4).
 Column (16) = From Column (16), Table No. 28.
 Column (17) = Column (16) * 0.0396694.
 Column (18) = Column (17) + Column (4).
 Column (19) = Column (5) x Column (9).
 Column (20) = Column (5) x Column (12).
 Column (21) = Column (5) x Column (15).
 Column (22) = Column (5) x Column (18).
 Column (23) = Sum of Columns (19), (20), (21), (22).
 Same as column (5); same as Table 22, Column (10).

FOR YEARS PRECEDING 1971: Refer to Volume 5, August 1976, Page I-75.

TABLE NO. 30

RIVERSIDE HIGHLAND WATER COMPANY
WATER PRODUCTION FROM LYTLE, BUNKER HILL, COLTON AND RIVERSIDE BASINS IN SAN BERNARDINO AND RIVERSIDE COUNTIES
AND THE DELIVERY OF THE PRODUCTION IN SAN BERNARDINO AND RIVERSIDE COUNTIES
 (Quantities in Acre Feet)

PRODUCTION IN SAN BERNARDINO COUNTY

Year	Domestic Supply			Commingled Sources						Riverside Basins Well	Production in Riverside County for Uses Therein	Agri. Supply for portion of Riverside Co. Demand	TOTAL PRODUCTION
	Lytle Creek Wells	Colton Basin	Riverside Basin Wells	Bunker Hill Basin	Colton Basin	Riverside Basin	Total Commingled Sources	Riverside Basins Well					
LC #1 & #8	Basin Well RH 4a	Basin Wells RH 20 LV #1 & #3	RH 2, 12, 18, 24	Rice Thorn Ward Warren	Basin	RH 17	La Sierra Water Co.	Commingled Sources	RH 7	RH 21 & 22	RH 7, 21, 22	(13)	
(1)	(2)	(3)	(4)	(5)	(6)	(7)	(8)	(9)	(10)	(11)	(12)	(13)	
1971	1,669	256	669	2,343	0	-	2,734	0	5,077	1,901	2,098	3,999	11,670
1972	1,468	285	789	3,064	0	-	1,868	0	4,932	1,572	1,368	2,940	10,414
1973	1,282	212	832	2,230	0	-	1,903	0	4,133	1,339	1,270	2,609	9,068
1974	1,374	282	833	2,714	279	-	1,283	0	4,276	1,255	1,533	2,788	9,553
1975	1,302	300	805	3,407	0	-	871	0	4,278	1,340	1,227	2,567	9,252
1976	1,468	170	839	3,052	0	-	1,469	0	4,521	1,284	1,320	2,604	9,602
1977	1,406	332	663	2,177	0	-	2,343	0	4,520	1,693	1,088	2,781	9,702
1978	964	270	834	386	0	-	1,629	0	2,015	1,460	1,296	2,756	6,839
1979	1,352	191	875	2,017	0	-	1,488	0	3,505	1,513	975	2,488	8,411
1980	1,600	0	1002	2,077	0	-	1,926	0	4,003	1,356	1,000	2,356	8,961
1981	1,806	0	1222	1,798	0	-	2,200	0	3,998	1,543	1,272	2,815	9,841
1982	1,538	0	891	1,257	0	-	1,679	0	2,936	760	1,153	1,913	7,278
1983	2,248	0	698	914	0	-	1,299	0	2,213	539	1,033	1,572	6,731
1984	2,300	83	946	2,459	0	-	2,498	0	4,957	1,101	2,592	3,693	11,979
1985	1,880	675	1103	1,432	0	-	2,198	0	3,630	1,174	1,917	3,091	10,379
1986	2,138	721	1039	2,606	0	-	175	0	2,781	875	2,017	2,892	9,571
1987	2,170	471	596	1,749	0	-	91	0	1,840	945	1,813	2,758	7,835
1988	2,289	256	754	2,486	0	-	0	0	2,486	1,031	1,525	2,556	8,341
1989	2,140	158	1728	2,541	0	-	0	0	2,541	830	1,429	2,259	8,826

Replaced by Table 23R starting with 1990.

(1) = Table No. 19, Column (5). (5) = Table No. 22, Column (2). (8) = Table No. 22, Column (3). (11) = Table No. 21, Column (15).
 (2) = Table No. 20, Column (4). (6) = N/A after 1966. (9) = Columns (4)+(5)+(7)+(8). (12) = Column (10) + (11).
 (3) = Table No. 21, Columns (6)+(7)+(8)+(9). (7) = Table No. 21, Column (5). (10) = Table No. 21, Column (3). (13) = Columns (1)+(2)+(3)+(4)+(5)+(7)+(8)+(10)+(11).
 (4) = Table No. 19, Column (15).

FOR YEARS PRECEDING 1971: Refer to Volume 5, August 1976, Page I-77.

TABLE NO. 30

RIVERSIDE HIGHLAND WATER COMPANY
WATER PRODUCTION FROM LYTLE, BUNKER HILL, COLTON AND RIVERSIDE BASINS IN SAN BERNARDINO AND RIVERSIDE COUNTIES
AND THE DELIVERY OF THE PRODUCTION IN SAN BERNARDINO AND RIVERSIDE COUNTIES
 (Quantities in Acre Feet)

DOMESTIC SYSTEM

LYTLE CREEK AREA

Year	Domestic Demand			Production for Domestic Demand						Domestic Export to Riverside County			Dom Export to San Bernardino Co.			Residual Production Available for Irrigation in S.B. COUNTY					
	San Bernardino County	Riv. County	Total	Lytle Creek	Colton Basin RH 4&4A	Riverside North			Lytle Creek	Colton	Riv. North	From Lytle Creek	From Colton	From Riv. North	From Lytle Creek	From Colton	From Riv. North	Total Production	San Bernardino County	Riv. Co.	CO. FOR IRRIG. & DOMESTIC
						RH 3,RH 20	LV 1,2,3	% of Production													
	(1)	(2)	(3)	(4)*	(5)	(6)	(7)	(8)	(9)	(10)	(11)	(12)	(13)	(14)	(15)	(16)	(17)	(18)	(19)		
1971	1,975	61	2,036	1,111	256	669	59.18%	12.57%	32.85%	36	8	20	1,075	248	649	1,669	558	-	1,633		
1972	1,911	95	2,006	932	285	789	57.02%	14.21%	39.33%	54	14	37	878	271	752	1,468	536	-	1414		
1973	1,771	56	1,827	783	212	832	54.85%	11.60%	45.54%	30	6	25	752	206	807	1,282	499	-	1,252		
1974	1,901	58	1,960	845	282	833	52.69%	14.39%	42.51%	31	8	25	814	274	808	1,374	529	-	1,343		
1975	1,835	56	1,891	786	300	805	50.52%	15.86%	42.57%	29	9	24	758	291	781	1,302	516	-	1273		
1976	1,892	56	1,947	938	170	839	48.20%	8.73%	43.08%	27	5	24	911	165	815	1,468	530	-	1,441		
1977	1,804	55	1,859	864	332	663	46.51%	17.86%	35.66%	26	10	20	838	322	643	1,406	542	-	1,380		
1978	1,895	71	1,965	861	270	834	43.87%	13.74%	42.43%	31	10	30	830	260	804	964	103	-	933		
1979	2,239	83	2,322	1,256	191	875	54.09%	8.23%	37.68%	45	7	31	1,211	184	844	1,352	96	-	1,307		
1980	2,455	103	2,558	1,556	0	1,002	60.83%	0.00%	39.18%	63	0	40	1,493	0	962	1,600	44	-	1,537		
1981	2,704	116	2,820	1,598	0	1,222	56.87%	0.00%	43.33%	66	0	50	1,532	0	1,172	1,806	208	-	1,740		
1982	2,280	88	2,369	1,478	0	891	62.37%	0.00%	37.62%	55	0	33	1,423	0	858	1,538	60	-	1,483		
1983	2,848	107	2,955	2,257	0	698	76.39%	0.00%	23.62%	81	0	25	2,175	0	673	2,248	0	-	2,167		
1984	3,213	105	3,319	2,290	83	946	69.00%	2.50%	28.51%	73	2	30	2,217	81	916	2,300	10	-	2,227		
1985	3,191	118	3,309	1,531	675	1103	46.27%	20.40%	33.33%	55	24	39	1,476	651	1,064	1,880	349	-	1,825		
1986	3,433	146	3,579	1,819	721	1,039	50.82%	20.15%	29.03%	74	30	42	1,745	691	997	2,138	319	-	2,064		
1987	3,022	136	3,158	2,091	471	596	66.22%	14.92%	18.87%	90	20	26	2,001	451	570	2,170	79	-	2,080		
1988	3,031	176	3,208	2,198	256	754	68.52%	7.98%	23.51%	121	14	41	2,077	242	713	2,289	91	-	2,168		
1989	3,511	382	3,893	2,007	158	1,728	51.56%	4.06%	44.38%	197	16	170	1,810	142	1,558	2,140	133	-	1,943		

Replaced by Table 23R starting with 1990.

(1) = Table No. 29, Column (22).

(2) = Table No. 29, Column (20).

(3) = Column (1) + Column (2).

(4) = Column (3) - [Column (6) + Column (5)].

(5) = Table No. 30, Column (2).

(6) = Table No. 30, Sheet 1, Column (3).

(7) = Column (4) + Column (3).

(8) = Column (5) + Column (3).

(9) = Column (6) + Column (3).

(10) = Column (2) x Column (7).

(11) = Column (2) x Column (8).

(12) = Column (2) x Column (9).

(13) = Column (4) - Column (10).

(14) = Column (5) - Column (11).

(15) = Column (6) - Column (12).

(16) = Table 19, Column (5).

(17) = Column (16) - Column (4).

(18) = Company method of operation.

(19) = Column (16) - Column (10).

* Production cannot exceed Table 19, Column 5.

FOR YEARS PRECEDING 1971: Refer to Volume 5, August 1976, Page I-79.

TABLE NO. 30

RIVERSIDE HIGHLAND WATER COMPANY
WATER PRODUCTION FROM LYTLE, BUNKER HILL, COLTON AND RIVERSIDE BASINS IN SAN BERNARDINO AND RIVERSIDE COUNTIES
AND THE DELIVERY OF THE PRODUCTION IN SAN BERNARDINO AND RIVERSIDE COUNTIES
 (Quantities in Acre Feet)

Year	Irrigation Demand			San Bernardino County		Riverside County		% Commingled Water		Irrigation Deliveries in San Bernardino from commingled Water Sources					Irrigation Deliveries in Riverside Co. from commingled Water Sources					
	Total	San Bernardino County	Riverside County	Lytle	Irrig. from	Irri from	Irrig. from	Water for	Used in S.B. Co.	Used in Riv. Co.	Bunker Hill		Colton	Riverside Basin		Bunker Hill		Colton	Riverside Basin	
				Area Wtr. for Irri.	Commingled supply	R.H. 7	Commingled R.H. 22				R.H. Wells	Rice Thorn	R.H. Wells	La Sierra Water Co.	R.H. Wells	Rice Thorn	R.H. Wells	La Sierra Water Co.		
(1)	(2)	(3)	(4)	(5)	(6)	(7)	(8)	(9)	(10)	(11)	(12)	(13)	(14)	(15)	(16)	(17)	(18)	(19)	(20)	
1971	9,633	2,187	7,447	558	1,629	3,999	3,448	5,077	32.09%	67.91%	752	0	-	877	0	1,591	0	-	1,857	0
1972	8,408	1,848	6,559	536	1,312	2,940	3,619	4,932	26.61%	73.39%	815	0	-	497	0	2,249	0	-	1,371	0
1973	7,241	1,412	5,829	499	913	2,609	3,220	4,133	22.09%	77.91%	493	0	-	420	0	1,737	0	-	1,483	0
1974	7,593	1,531	6,062	529	1,002	2,788	3,274	4,276	23.43%	76.57%	636	65	-	301	0	2,078	214	-	982	0
1975	7,360	1,423	5,937	516	907	2,567	3,370	4,278	21.21%	78.79%	723	0	-	185	0	2,684	0	-	686	0
1976	7,654	1,433	6,222	530	903	2,604	3,618	4,521	19.97%	80.03%	610	0	-	293	0	2,442	0	-	1,176	0
1977	7,842	1,454	6,388	542	912	2,781	3,607	4,519	20.18%	79.82%	439	0	-	473	0	1,738	0	-	1,870	0
1978	4,873	717	4,156	103	614	2,756	1,400	2,015	30.49%	69.51%	118	0	-	497	0	268	0	-	1,132	0
1979	6,089	921	5,168	96	824	2,488	2,680	3,505	23.52%	76.48%	474	0	-	350	0	1,543	0	-	1,138	0
1980	6,403	1,052	5,351	44	1,007	2,356	2,995	4,003	25.17%	74.83%	523	0	-	485	0	1,554	0	-	1,441	0
1981	7,021	1,116	5,904	208	908	2,815	3,089	3,998	22.72%	77.28%	408	0	-	500	0	1,390	0	-	1,700	0
1982	4,909	744	4,165	60	683	1,913	2,252	2,936	23.28%	76.72%	293	0	-	391	0	964	0	-	1,288	0
1983	3,776	368	3,408	0	368	1,572	1,836	2,204	16.70%	83.30%	153	0	-	217	0	761	0	-	1,082	0
1984	8,660	904	7,756	10	894	3,693	4,063	4,957	18.03%	81.97%	443	0	-	450	0	2,016	0	-	2,048	0
1985	7,070	737	6,333	349	388	3,091	3,242	3,630	10.68%	89.32%	153	0	-	235	0	1,279	0	-	1,963	0
1986	5,992	388	5,604	319	69	2,892	2,712	2,781	2.48%	97.52%	65	0	-	4	0	2,541	0	-	171	0
1987	4,677	236	4,441	79	156	2,758	1,683	1,840	8.50%	91.50%	149	0	-	8	0	1,600	0	-	83	0
1988	5,133	152	4,981	91	60	2,556	2,425	2,486	2.42%	97.58%	60	0	-	0	0	2,426	0	-	0	0
1989	4,932	157	4,775	133	25	2,259	2,516	2,540	0.97%	99.03%	25	0	-	0	0	2,516	0	-	0	0

Replaced by Table 23R starting with 1990.

- | | | |
|---|--|---|
| (1) = Columns (2) + (3). | (11) = Table 30, Sheet 1, Column (4) x Column (9) this page. | (16) = Table 30, Sheet 1, Column (4) x Column (10) this page. |
| (2) = Table No. 29, Column (21). | (12) = Table 30, Sheet 1, Column (5) x Column (9) this page. | (17) = Table 30, Sheet 1, Column (5) x Column (10) this page. |
| (3) = Table No. 29, Column (19). | (13) = Table 30, Sheet 1, Column (6) x Column (9) this page. | (18) = Table 30, Sheet 1, Column (6) x Column (10) this page. |
| (4) = Table No. 30, Sheet 2, Column (17). | (14) = Table 30, Sheet 1, Column (9) x Column (9) this page. | (19) = Table 30, Sheet 1, Column (7) x Column (10) this page. |
| (5) = Column (2) - Column (4). | (15) = Table 30, Sheet 1, Column (8) x Column (9) this page. | (20) = Table 30, Sheet 1, Column (8) x Column (10) this page. |
| (6) = Table No. 30, Sheet 1, Column (12). | | |
| (7) = Column (3) - Column (6). | | |
| (8) = Column (5) + Column (7). | | |
| (9) = Column (5) + Column (8). | | |
| (10) = Column (7) ÷ Column (8). | | |

FOR YEARS PRECEDING 1971: Refer to Volume 5, August 1976, Page I-81.

TABLE NO. 31

RIVERSIDE HIGHLAND WATER COMPANY
WATER PRODUCTION FROM LYTLE, BUNKER HILL, COLTON & RIVERSIDE BASINS
IN SAN BERNARDINO AND RIVERSIDE COUNTIES AND THE DELIVERY OF THE PRODUCTION IN
SAN BERNARDINO AND RIVERSIDE COUNTIES

(Quantities in Acre Feet)

Year	PRODUCTION DELIVERED NORTH OF COUNTY LINE IN SAN BERNARDINO COUNTY									PRODUCTION DELIVERED SOUTH OF COUNTY LINE IN RIVERSIDE COUNTY									TOTAL PRODUCTION NORTH OF THE COUNTY LINE	TOTAL PRODUCTION SOUTH OF THE COUNTY LINE	TOTAL PRODUCTION						
	Lytle			Bunker Hill			Colton			Riverside			Lytle			Bunker Hill						Colton			Riverside		
	R.H. Wells	R.H. Wells	Ward Warren	Total Bunker Hill	R.H. Wells	R.H. Wells	Sierra Wells	Total Riverside Basin	TOTAL PRODUCTION DELIVERED	R.H. Wells	R.H. Wells	Ward Warren	Total Bunker Hill	R.H. Wells	R.H. Wells	Sierra Wells	Total Riverside Basin	TOTAL PRODUCTION DELIVERED				OF THE COUNTY LINE	OF THE COUNTY LINE	TOTAL PRODUCTION			
(1)	(2)	(3)	(4)	(5)	(6)	(7)	(8)	(9)	(10)	(11)	(12)	(13)	(14)	(15)	(16)	(17)	(18)	(19)	(20)	(21)	(22)						
1971	1,633	752	0	752	248	1,526	0	1,526	4,159	36	1,591	0	1,591	8	3,778	0	3,778	5,413	9,572	2,098	11,670						
1972	1,414	815	0	815	271	1,249	0	1,249	3,749	54	2,249	0	2,249	14	2,980	0	2,980	5,297	9,046	1,368	10,414						
1973	1,252	493	0	493	206	1,227	0	1,227	3,177	30	1,737	0	1,737	6	2,847	0	2,847	4,621	7,798	1,270	9,068						
1974	1,343	636	65	701	274	1,109	0	1,109	3,427	31	2,078	214	2,292	8	2,262	0	2,262	4,593	8,020	1,533	9,553						
1975	1,273	723	0	723	291	966	0	966	3,253	29	2,684	0	2,684	9	2,050	0	2,050	4,772	8,025	1,227	9,252						
1976	1,441	610	0	610	165	1,108	0	1,108	3,324	27	2,442	0	2,442	5	2,484	0	2,484	4,958	8,282	1,320	9,602						
1977	1,380	439	0	439	322	1,116	0	1,116	3,258	26	1,738	0	1,738	10	3,583	0	3,583	5,356	8,614	1,088	9,702						
1978	933	118	0	118	260	1,301	0	1,301	2,612	31	268	0	268	10	2,622	0	2,622	2,931	5,543	1,296	6,839						
1979	1,307	474	0	474	184	1,194	0	1,194	3,160	45	1,543	0	1,543	7	2,682	0	2,682	4,276	7,436	975	8,411						
1980	1,537	523	0	523	0	1,446	0	1,446	3,507	63	1,554	0	1,554	0	2,838	0	2,838	4,454	7,961	1,000	8,961						
1981	1,740	408	0	408	0	1,672	0	1,672	3,820	66	1,390	0	1,390	0	3,293	0	3,293	4,749	8,569	1,272	9,841						
1982	1,483	293	0	293	0	1,249	0	1,249	3,024	55	964	0	964	0	2,081	0	2,081	3,101	6,125	1,153	7,278						
1983	2,167	153	0	153	0	890	0	890	3,209	81	761	0	761	0	1,646	0	1,646	2,489	5,698	1,033	6,731						
1984	2,227	443	0	443	81	1,366	0	1,366	4,118	73	2,016	0	2,016	2	3,179	0	3,179	5,269	9,387	2,592	11,979						
1985	1,825	153	0	153	651	1,298	0	1,298	3,927	55	1,279	0	1,279	24	3,177	0	3,177	4,535	8,462	1,917	10,379						
1986	2,064	65	0	65	691	1,001	0	1,001	3,820	74	2,541	0	2,541	30	1,088	0	1,088	3,734	7,554	2,017	9,571						
1987	2,080	149	0	149	451	578	0	578	3,258	90	1,600	0	1,600	20	1,054	0	1,054	2,764	6,022	1,813	7,835						
1988	2,168	60	0	60	242	713	0	713	3,183	121	2,426	0	2,426	14	1,072	0	1,072	3,633	6,816	1,525	8,341						
1989	1,943	25	0	25	142	1,558	0	1,558	3,669	197	2,516	0	2,516	16	1,000	0	1,000	3,728	7,397	1,429	8,826						
1990																											

Replaced by Table 23R starting with 1990.

(2) = Table No. 30, Sheet No. 2, Column (19).	(11) = Table No. 30, Sheet No. 2, Column (10).	(20) = Column (10) + Column (19).
(3) = Table No. 30, Sheet No. 3, Column (11).	(12) = Table No. 30, Sheet No. 3, Column (17).	(21) = Table No. 30, Sheet No. 1, Column (11).
(4) = Table No. 30, Sheet No. 3, Column (12).	(13) = Table No. 30, Sheet No. 3, Column (17).	(22) = Column (20) + Column (21).
(5) = Column (3) + Column (4).	(14) = Column (12) + Column (13).	Same as Table 22, Column (10).
(6) = Table No. 30, Sheet No. 2, Column (14).	(15) = Table No. 30, Sheet No. 2, Column (11).	
(7) = Table No. 30, Sheet No. 2, Column (15) + Sheet No. 3, Column (14).	(16) = Table No. 30, Sheet No. 1, Column (10) + Sheet No. 2, Column (12) + Sheet No. 3, ColNote on original worksheet - As verified by inventory of agricultu	
(8) = Table No. 30, Sheet No. 3, Column (15)	(17) = Table No. 30, Sheet No. 3, Column (20).	and domestic deliveries in Riverside County
(9) = Column (7) + Column (8).	(18) = Column (16) + Column (17).	
(10) = Column (2) + (5) + (6) + (9).	(19) = Column (11) + (14) + (15) + (18).	

FOR YEARS PRECEDING 1971: Refer to Volume 5, August 1976, Page I-83

TABLE NO. 31-A

page 1 of 2

TOTAL PRODUCTION BY RIVERSIDE HIGHLAND WATER COMPANY
FROM THE SAN BERNARDINO BASIN AREA
(INCLUDES LYTLE AND BUNKER HILL BASINS)
AS DELIVERED IN SAN BERNARDINO AND RIVERSIDE COUNTIES
(Quantities in Acre Feet)

Calendar Year	Total Deliveries in San Bernardino County	Total Deliveries in Riverside County	Total Production From San Bernardino Basin Area	
(1)	(2)	(3)	(4)	
Adjusted Right	2,449	1,845	4,294	
1971	2,385	1,627	4,012	
1972	2,229	2,303	4,532	
1973	1,744	1,768	3,512	
1974	1,979	2,109	4,088	
1975	1,996	2,713	4,709	
1976	2,051	2,469	4,520	
1977	1,820	1,763	3,583	
1978	1,051	299	1,350	
1979	1,782	1,587	3,369	
1980	2,060	1,617	3,677	
1981	2,148	1,456	3,604	
1982	1,776	1,019	2,795	
1983	2,319	843	3,162	
1984	2,671	2,088	4,759	
1985	1,978	1,334	3,312	
1986	2,128	2,616	4,744	
1987	2,229	1,690	3,919	
1988	2,229	2,546	4,775	
1989	1,968	2,713	4,681	
1990	2,313	1,779	4,092	
1991	1,669	1,352	3,021	
1992	2,275	1,777	4,052	
1993	1,777	1,464	3,241	
1994	2,201	2,123	4,324	
1995	2,146	1,809	3,955	
1996	2,756	2,295	5,051	
1997	2,656	2,283	4,939	
1998	1,961	1,289	3,250	
1999	2,082	849	2,931	*
2000	2,811	45	2,856	*
2001	2,543	122	2,665	*
2002	2,271	128	2,399	*
2003	2,036	1,845	3,881	* **
2004	1,304	450	1,754	**
2005	1,533	1,845	3,378	**

Adjusted Right from Annual Report Table 3

Note: Excludes City of Riverside production (Ward Warren) in Bunker Hill Basin which is delivered to Riverside Highland Water Company.

(2) = Table No. 31, Column (2) + (3); beginning with 1990, Table 23R, page 2, Column (6).

(3) = Table No. 31, Column (11) + (12); beginning with 1990, Table 23R, page 2, Column (7).
Beginning with 2003, Table 23R, page 2, Column (7) - Table 22, Column (4)

(4) = Column (2) + (3), Same as Table 22, Col. (5).

* Excludes High Groundwater Mitigation Program production

** Includes C of R stock water from Cooley wells

Adjusted Right from Annual Report Table 3

FOR YEARS PRECEDING 1971: Refer to Volume 5, August 1976, Page 1-85.

TABLE NO. 31-A

TOTAL PRODUCTION BY RIVERSIDE HIGHLAND WATER COMPANY
FROM THE SAN BERNARDINO BASIN AREA
(INCLUDES LYTTLE AND BUNKER HILL BASINS)
AS DELIVERED IN SAN BERNARDINO AND RIVERSIDE COUNTIES
 (Quantities in Acre Feet)

Calendar Year	Total Deliveries in San Bernardino County	Total Deliveries in Riverside County	Total Production From San Bernardino Basin Area	
(1)	(2)	(3)	(4)	
Adjusted Right	2,449	1,845	4,294	
2006	2,304	1,845	4,149	**
2007	1,772	1,861	3,633	**
2008	2,054	676	2,730	**
2009	1,073	575	1,648	**
2010	629	507	1,136	**
2011	1,087	568	1,655	**
2012	1,523	612	2,135	**
2013				
2014				
2015				
2016				
2017				
2018				
2019				
2020				
2021				
2022				
2023				
2024				
2025				
2026				
2027				
2028				
2029				
2030				
2031				
2032				
2033				
2034				
2035				
2036				
2037				
2038				
2039				
2040				

Adjusted Right from Annual Report Table 3

Note: Excludes City of Riverside production (Ward Warren) in Bunker Hill Basin which is delivered to Riverside Highland Water Company.

(2) = Table No. 31, Column (2) + (3); beginning with 1990, Table 23R, sheet 2, page 2, Column (6).

(3) = Table No. 31, Column (11) + (12); beginning with 1990, Table 23R, sheet 2, page 2, Column (7). Beginning with 2003, Table 23R, page 2, Column (7) - Table 22, Column (4)

(4) = Column (2) + (3), Same as Table 22, Col. (5).

** Includes C of R stock water

Adjusted Right from Annual Report Table 3

FOR YEARS PRECEDING 1971: Refer to Volume 5, August 1976, Page 1-85.

TABLE 31-B

NOT REQUIRED FOR UPDATING AFTER 1970

Volume 5

Tables 32-34

Meeks & Daley Water Company
Water production and
distribution

TABLE NO. 32

MEEKS & DALEY WATER COMPANY &
 AGUA MANSA WATER COMPANY
 WATER PRODUCTION FROM THE SAN BERNARDINO BASIN AREA
 AND THE COLTON BASIN AREA

(Quantities in Acre Feet)

Year	San Bernardino Basin Area Production															TOTAL PRODUCTION IN SAN BERNARDINO BASIN AREA		Net Production Delivery to C of R for Delivery		Colton Basin Production #36				
	E St.°	#51°	#54°	Coburn	#59	New E St.	#66°	Warm Creek°	Ditch°	Workman						Leased wells					SAN BERNARDINO BASIN AREA	Delivery to C of R	for Delivery	184W21N01S 3601510
										#69	#91	*Warren #4	*Raub #6	*Warren #1	*Raub 8	*Raub 5	PRODUCTION IN	Production	#36					
184W15M02S 3601511	184W15N05S 3601512	184W16R03S 3601513	184W16O09S 3601737	184W15L03S 3601887	184W15M10S 3602169	184W15E 3602329	184W16Q 3601514	184W16Q 3601515	184W16R04S 3603214	184W15M11S 3603215	184W22H02S 3602863	184W14N10S 3602864	184W22H01S 3604005	184W-14N11S 3603905	184W-14N09S 3603906	(14)	(15)	(16)	(17)					
1971	0	-	0	178	0	2,502	0	0	0	222						2,902	0	2,902	0					
1972	0	-	0	265	1,503	1,678	0	0	0	81						3,527	0	3,527	0					
1973	0	-	0	117	1,246	1,412	0	0	0	204						2,979	0	2,979	484					
1974	-	-	-	354	2,606	1,379	-	-	-	165						4,504	275	4,229	0					
1975	-	-	-	276	1,649	2,025	-	-	-	0						3,950	1,649	2,301	1,350					
1976	-	-	-	329	2,305	2,759	-	-	-	0						5,393	1,895	3,498	1,860					
1977	-	-	-	4	1,848	2,368	-	-	-	0						4,220	1,848	2,372	2,018					
1978	-	-	-	162	1,518	574	-	-	-	0						2,254	1,385	869	422					
1979	-	-	-	207	1,549	2,174	-	-	-	0						3,930	1,231	2,699	1,698					
1980	-	-	-	155	2,102	76	-	-	-	0						2,333	1,650	683	0					
1981	-	-	-	8	3,084	0	-	-	-	-						3,092	2,496	596	0					
1982	-	-	-	127	1,845	1,744	-	-	-	-						3,716	1,471	2,245	910					
1983	-	-	-	0	2,583	68	-	-	-	-						2,651	2,317	334	50					
1984	-	-	-	249	2,947	1,969	-	-	-	-						5,165	2,567	2,598	1,383					
1985	-	-	-	165	2,815	2,405	-	-	-	-						5,385	2,492	2,893	1,554					
1986	-	-	-	274	1,990	2,600	-	-	-	-	38	668				5,570	2,660	2,910	1,575					
1987	-	-	-	161	2,400	2,353	-	-	-	-	0	0				4,914	2,274	2,640	1,560					
1988	-	-	-	355	2,251	2,360	-	-	-	-	0	0				4,966	2,251	2,715	1,754					
1989	-	-	-	524	2,853	1,477	-	-	-	-	399	139				5,392	3,043	2,349	1,538					
1990	-	-	-	352	2,189	0	-	-	-	-	519	791				3,851	3,389	462	1,691					
1991	-	-	-	401	2,625	-	-	-	-	-	0	1,098	302			4,426	2,997	1,429	1,530					
1992	-	-	-	224	1,946	-	-	-	-	224	309	447	950			4,100	3,285	815	1,209					
1993	-	-	-	438	2,181	-	-	-	-	182	1,387	447	378			5,013	2,422	2,591	0					
1994	-	-	-	401	2,154	-	-	-	-	89	895	347	639			4,525	3,127	1,398	586					
1995	-	-	-	343	2,322	-	-	-	-	50	1	750	94			3,560	3,166	394	344					
1996	-	-	-	160	1,291	-	-	-	-	130	613	1,656	62			3,912	3,009	903	362					
1997	-	-	-	134	2,094	-	-	-	-	224	464	1,249	0			4,165	3,343	822	484					
1998	-	-	-	134	1,711	-	-	-	-	200	237	427	1,119			3,828	3,257	571	88					
1999	-	-	-	35	2,620	-	-	-	-	23	372	1,107	2,132			6,289	5,859	430	1,066					
2000	-	-	-	32	619	-	-	-	-	459	3	940	1,779			3,832	3,338	494	102					
2001	-	-	-	65	259	-	-	-	-	0	1	830	2,516			3,671	3,346	325	285					
2002	-	-	-	0	1,373	-	-	-	-	0	1,118	864	2,445			5,800	3,490	2,310	1,322					
2003	-	-	-	0	1,234	-	-	-	-	0	1,078	1,529	2,972	627		7,440	5,210	2,230	844					
2004	-	-	-	0	165	-	-	-	-	0	141	278	2,327	871		3,782	3,476	306	120					
2005	-	-	-	-	19	-	-	-	-	0	20	958	2,266	1,316	1,021	291	5,891	5,852	39	30				

Note: No production from the Riverside Basin Area.

* Warren #1, Warren #4 & Raub #6 are owned by the C of R and are being pumped by M & D into Riverside's system to meet stock rights.

Data from Temescal, Meeks & Daley records unless otherwise noted.

Column (12) = same as Table No. 1, Sheet 2, Line 68.

° Abandoned &/or file closed.

Column (13) = same as Table No. 1, Sheet 2, Line 69.

FOR YEARS PRECEDING 1971: Refer to Volume 5, August 1976, Page I-91.

Column (15) = Water delivered to C of R from M&D #59 and leased production: Table 1, Sheet 2, Line 69d.

TABLE NO. 32

MEEKS & DALEY WATER COMPANY &
 AGUA MANSA WATER COMPANY
 WATER PRODUCTION FROM THE SAN BERNARDINO BASIN AREA
 AND THE COLTON BASIN AREA

(Quantities in Acre Feet)

Year	San Bernardino Basin Area Production																			TOTAL		Net		Colton Basin	
	Workman											Leased wells								PRODUCTION IN	Delivery	Production	#36	Sperry	
	E St. °	#51°	#54°	Coburn	#59	New E St.	#66°	Warm Creek°	Ditch°	#69	#91	*Warren #4	*Raub #6	*Warren #1	*Raub 8	*Raub 5	*Garner 6	*Garner 7	*Tippecanoe	*Raub #7	BASIN AREA	C of R	Delivery	3601510	3603950
(1)	(2)	(3)	(4)	(5)	(6)	(7)	(8)	(9)	(10)	(11)	(11a)	(12)	(13)	(13a)	(13b)	(13c)	(13d)	(13e)	(13f)	(13g)	(14)	(15)	(16)	(17)	(18)
2006	-	-	-	-	863	-	-	-	-	0	10	1,953	1,921	2,022	746	0					7,515	7,092	423	222	
2007	-	-	-	-	1,330	-	-	-	-	-	439	1,277	3,020	1,525	0	0					7,591	6,509	1,082	682	
2008	-	-	-	-	1,374	-	-	-	-	-	694	903	1,226	635	0	0			0		4,832	2,909	1,923	883	
2009	-	-	-	-	21	-	-	-	-	-	12	0	1,222	0	1,257	841	1,360	1,632	0		6,345	6,312	33	298	
2010	-	-	-	-	0	-	-	-	-	-	0	7	1,298	0	1,870	699	0	0	0	2,864	6,738	6,738	0	0	0
2011	-	-	-	-	3	-	-	-	-	-	7	630	1,841	0	1,553	1,154	0	0	0	1,939	7,127	7,117	10	-	101
2012	-	-	-	-	0	-	-	-	-	-	0	857	2,082	0	366	1,341	0	0	0	2,471	7,117	7,117	0	-	0
2013	-	-	-	-	-	-	-	-	-	-	-	-	-	-	-	-	-	-	-	-	-	-	-	-	-
2014	-	-	-	-	-	-	-	-	-	-	-	-	-	-	-	-	-	-	-	-	-	-	-	-	-
2015	-	-	-	-	-	-	-	-	-	-	-	-	-	-	-	-	-	-	-	-	-	-	-	-	-
2016	-	-	-	-	-	-	-	-	-	-	-	-	-	-	-	-	-	-	-	-	-	-	-	-	-
2017	-	-	-	-	-	-	-	-	-	-	-	-	-	-	-	-	-	-	-	-	-	-	-	-	-
2018	-	-	-	-	-	-	-	-	-	-	-	-	-	-	-	-	-	-	-	-	-	-	-	-	-
2019	-	-	-	-	-	-	-	-	-	-	-	-	-	-	-	-	-	-	-	-	-	-	-	-	-
2020	-	-	-	-	-	-	-	-	-	-	-	-	-	-	-	-	-	-	-	-	-	-	-	-	-
2021	-	-	-	-	-	-	-	-	-	-	-	-	-	-	-	-	-	-	-	-	-	-	-	-	-
2022	-	-	-	-	-	-	-	-	-	-	-	-	-	-	-	-	-	-	-	-	-	-	-	-	-
2023	-	-	-	-	-	-	-	-	-	-	-	-	-	-	-	-	-	-	-	-	-	-	-	-	-
2024	-	-	-	-	-	-	-	-	-	-	-	-	-	-	-	-	-	-	-	-	-	-	-	-	-
2025	-	-	-	-	-	-	-	-	-	-	-	-	-	-	-	-	-	-	-	-	-	-	-	-	-
2026	-	-	-	-	-	-	-	-	-	-	-	-	-	-	-	-	-	-	-	-	-	-	-	-	-
2027	-	-	-	-	-	-	-	-	-	-	-	-	-	-	-	-	-	-	-	-	-	-	-	-	-
2028	-	-	-	-	-	-	-	-	-	-	-	-	-	-	-	-	-	-	-	-	-	-	-	-	-
2029	-	-	-	-	-	-	-	-	-	-	-	-	-	-	-	-	-	-	-	-	-	-	-	-	-
2030	-	-	-	-	-	-	-	-	-	-	-	-	-	-	-	-	-	-	-	-	-	-	-	-	-
2031	-	-	-	-	-	-	-	-	-	-	-	-	-	-	-	-	-	-	-	-	-	-	-	-	-
2032	-	-	-	-	-	-	-	-	-	-	-	-	-	-	-	-	-	-	-	-	-	-	-	-	-
2033	-	-	-	-	-	-	-	-	-	-	-	-	-	-	-	-	-	-	-	-	-	-	-	-	-
2034	-	-	-	-	-	-	-	-	-	-	-	-	-	-	-	-	-	-	-	-	-	-	-	-	-
2035	-	-	-	-	-	-	-	-	-	-	-	-	-	-	-	-	-	-	-	-	-	-	-	-	-
2036	-	-	-	-	-	-	-	-	-	-	-	-	-	-	-	-	-	-	-	-	-	-	-	-	-
2037	-	-	-	-	-	-	-	-	-	-	-	-	-	-	-	-	-	-	-	-	-	-	-	-	-
2038	-	-	-	-	-	-	-	-	-	-	-	-	-	-	-	-	-	-	-	-	-	-	-	-	-
2039	-	-	-	-	-	-	-	-	-	-	-	-	-	-	-	-	-	-	-	-	-	-	-	-	-
2040	-	-	-	-	-	-	-	-	-	-	-	-	-	-	-	-	-	-	-	-	-	-	-	-	-

Note: No production from the Riverside Basin Area.
 Data from Temescal, Meeks & Daley records unless otherwise noted.
 * Abandoned &/or file closed.
 * Wells are owned by the C of R and are being pumped by M & D into Riverside's system.
 FOR YEARS PRECEDING 1971: Refer to Volume 5, August 1976, Page I-91.

Column (12) thru (13) = same as Table No. 1, Sheet 2, Line 68.
 Column (13) = from Table No. 1, Sheet 2, Line 69.
 Column (15) = Water delivered to C of R from M&D #59 and leased production: Table 1, Sheet 2, Line 69d.
 Column (16) = (14) - (15)
 Column (17) & (18) from Elsinore Valley MWD Recordation Filings

TABLE NO. 33

MEEKS & DALEY WATER COMPANY AND AGUA MANSA WATER COMPANY
WATER PRODUCTION FROM THE SAN BERNARDINO BASIN AREA
AND THE COLTON BASIN AREA DELIVERED IN SAN BERNARDINO COUNTY AND EXPORTED TO RIVERSIDE COUNTY
 (Quantities in Acre Feet by Calendar Year)

Year	San Bernardino Basin Area Net Production	Colton Basin Area Production	Total	Composition of Production		Delivery in S.B. County	Delivery in San Bernardino County		Production Exported to Riverside County			
				% San Bdn Basin Area	% Colton Basin Area		S.B. Basin Production	Colton Production	From			Total
									San Bdn Basin	Colton Basin	Riverside Basin	
(1)	(2)	(3)	(4)	(5)	(6)	(7)	(8)	(9)	(10)	(11)	(12)	
1971	2,902	0	2,902	100.00%	0.00%	383	383	0	2,519	0	-	2,519
1972	3,527	0	3,527	100.00%	0.00%	377	377	0	3,150	0	-	3,150
1973	2,979	484	3,463	86.02%	13.98%	291	250	41	2,729	443	-	3,172
1974	4,229	0	4,229	100.00%	0.00%	246	246	0	3,983	0	-	3,983
1975	2,301	1,350	3,651	63.02%	36.98%	266	168	98	2,133	1,252	-	3,385
1976	3,498	1,860	5,358	65.29%	34.71%	287	187	100	3,311	1,760	-	5,071
1977	2,372	2,018	4,390	54.03%	45.97%	271	146	125	2,226	1,893	-	4,119
1978	869	422	1,291	67.31%	32.69%	239	161	78	708	344	-	1,052
1979	2,699	1,698	4,397	61.38%	38.62%	270	166	104	2,533	1,594	-	4,127
1980	683	0	683	100.00%	0.00%	323	323	0	360	0	-	360
1981	596	0	596	100.00%	0.00%	358	358	0	238	0	-	238
1982	2,245	910	3,155	71.16%	28.84%	237	169	68	2,076	842	-	2,918
1983	334	50	384	86.98%	13.02%	282	245	37	89	13	-	102
1984	2,598	1,383	3,981	65.26%	34.74%	359	234	125	2,364	1,258	-	3,622
1985	2,893	1,554	4,447	65.06%	34.94%	322	209	113	2,684	1,441	-	4,125
1986	2,910	1,575	4,485	64.88%	35.12%	327	212	115	2,698	1,460	-	4,158
1987	2,640	1,560	4,200	62.86%	37.14%	306	192	114	2,448	1,446	-	3,894
1988	2,715	1,754	4,469	60.75%	39.25%	383	233	150	2,482	1,604	-	4,086
1989	2,349	1,538	3,887	60.43%	39.57%	397	240	157	2,109	1,381	-	3,490
1990	462	1,691	2,153	21.46%	78.54%	389	83	306	379	1,385	-	1,764
1991	1,429	1,530	2,959	48.29%	51.71%	394	190	204	1,239	1,326	-	2,565
1992	815	1,209	2,024	40.27%	59.73%	294	118	176	697	1,033	-	1,730
1993	2,591	0	2,591	100.00%	0.00%	276	276	0	2,315	0	-	2,315
1994	1,398	586	1,984	70.46%	29.54%	322	227	95	1,171	491	-	1,662
1995	394	344	738	53.39%	46.61%	271	145	126	249	218	-	467
1996	903	362	1,265	71.38%	28.62%	272	194	78	709	284	-	993
1997	822	484	1,306	62.94%	37.06%	218	137	81	685	403	-	1,088
1998	571	88	659	86.65%	13.35%	242	210	32	361	56	-	417
1999	430	1,066	1,496	28.74%	71.26%	312	90	222	340	844	-	1,184
2000	494	102	596	82.89%	17.11%	425	352	73	142	29	-	171
2001	325	285	610	53.28%	46.72%	360	192	168	133	117	-	250
2002	2,310	1,322	3,632	63.60%	36.40%	318	202	116	2,108	1,206	-	3,314
2003	2,230	844	3,074	72.54%	27.46%	67	49	18	2,181	826	-	3,007
2004	306	120	426	71.83%	28.17%	26	19	7	287	113	-	400
2005	39	30	69	56.52%	43.48%	7	4	3	35	27	-	62

(1) = Table No. 32, Column (16). (7) = Column (6) x (4). (11) No Production in Riverside Basin + Quantity shown is portion exported via canals and excludes Well No. 59. See Table 34 for total exported from San Bernardino Basin Area which includes Well No. 59.
 (2) = Table No. 32, Column (17). (8) = Column (6) x (5). (12) = Column (9) + (10) + (11).
 (3) = Column (1) + (2). (9) = Column (1) - (7).
 (4) = Column (1) + (3). (10) = Column (2) - (8).
 (5) = Column (2) ÷ (3).
 (6) = From M & D records, "Deliveries in vicinity of Colton".

FOR YEARS PRECEDING 1971: Refer to Volume 5, August 1976, Page I-94.

* Corrected during 1989 verification.

TABLE NO. 33

MEEKS & DALEY WATER COMPANY AND AGUA MANSA WATER COMPANY
WATER PRODUCTION FROM THE SAN BERNARDINO BASIN AREA
AND THE COLTON BASIN AREA DELIVERED IN SAN BERNARDINO COUNTY AND EXPORTED TO RIVERSIDE COUNTY
 (Quantities in Acre Feet by Calendar Year)

Year	San Bernardino Basin Area Net Production	Colton Basin Area Production	Total	Composition of Production		Delivery in S.B. County	Delivery in San Bernardino County		Production Exported to Riverside County			Total
				% San Bdno Basin Area	% Colton Basin Area		S.B. Basin Production	Colton Production	From San Bdno Basin	From Colton Basin	From Riverside Basin	
				(4)	(5)		(6)	(7)	(8)	(9)	(10)	
2006	423	222	645	65.58%	34.42%	0	0	0	423	222	-	645
2007	1,082	682	1,764	61.34%	38.66%	0	0	0	1,082	682	-	1,764
2008	1,923	883	2,806	68.53%	31.47%	-	-	-	1,923	883	-	2,806
2009	33	298	331	9.97%	90.03%	-	-	-	33	298	-	331
2010	0	0	0	0.00%	0.00%	-	-	-	0	0	-	0
2011	10	101	111	9.01%	90.99%	-	-	-	10	101	-	111
2012	0	0	0	0.00%	0.00%	-	-	-	0	0	-	0
2013						-	-	-			-	
2014						-	-	-			-	
2015						-	-	-			-	
2016						-	-	-			-	
2017						-	-	-			-	
2018						-	-	-			-	
2019						-	-	-			-	
2020						-	-	-			-	
2021						-	-	-			-	
2022						-	-	-			-	
2023						-	-	-			-	
2024						-	-	-			-	
2025						-	-	-			-	
2026						-	-	-			-	
2027						-	-	-			-	
2028						-	-	-			-	
2029						-	-	-			-	
2030						-	-	-			-	
2031						-	-	-			-	
2032						-	-	-			-	
2033						-	-	-			-	
2034						-	-	-			-	
2035						-	-	-			-	
2036						-	-	-			-	
2037						-	-	-			-	
2038						-	-	-			-	
2039						-	-	-			-	
2040						-	-	-			-	

(1) = Table No. 32, Column (16).
 (2) = Table No. 32, Column (17).
 (3) = Column (1) + (2).
 (4) = Column (1) ÷ (3).
 (5) = Column (2) ÷ (3).
 (6) = From M & D records, "Deliveries in vicinity of Colton".
 FOR YEARS PRECEDING 1971: Refer to Volume 5, August 1976, Page I-94.

(7) = Column (6) x (4).
 (8) = Column (6) x (5).
 (9) = Column (1) - (7).
 (10) = Column (2) - (8).

(11) No Production in Riverside Basin
 (12) = Column (9) + (10) + (11).
 + Quantity shown is portion exported via canals and excludes Well No. 59. See Table 34 for total exported from San Bernardino Basin Area which includes Well No. 59.

TABLE NO. 34

page 1 of 2

MEEKS & DALEY WATER COMPANY
WATER PRODUCTION FROM SAN BERNARDINO BASIN AREA
AND DELIVERIES WITHIN SAN BERNARDINO COUNTY
AND EXPORT TO RIVERSIDE COUNTY
(Quantities in Acre Feet)

Year	Production in the San Bernardino Basin Area	Deliveries within Colton & Riverside Basins in San Bernardino County	San Bernardino Basin Production Exported to Riverside County
Year	(1)	(2)	(3)
Adjusted Base Right	7,833	318	7,515
1971	2,902	383	2,519
1972	3,527	377	3,150
1973	2,979	250	2,729
1974	4,504	246	4,258
1975	3,950	168	3,782
1976	5,393	187	5,206
1977	4,220	146	4,074
1978	2,254	161	2,093
1979	3,930	166	3,764
1980	2,333	323	2,010
1981	3,092	358	2,734
1982	3,716	169	3,547
1983	2,651	245	2,406
1984	5,165	234	4,931
1985	5,385	209	5,176
1986	5,570	212	5,358
1987	4,914	192	4,722
1988	4,966	233	4,733
1989	5,392	240	5,152
1990	3,851	83	3,768
1991	4,426	190	4,236
1992	4,100	118	3,982
1993	5,013	276	4,737
1994	4,525	227	4,298
1995	3,560	145	3,415
1996	3,912	194	3,718
1997	4,165	137	4,028
1998	3,828	210	3,618
1999	6,289	90	6,199
2000	3,832	352	3,480
2001	3,671	192	3,479
2002	5,800	202	5,598
2003	7,440	49	7,391
2004	3,782	19	3,763
2005	5,891	4	5,887

Column (1) = From Table No. 32, Column (14).

Column (2) = From Table No. 33, Col. 7.

Column (3) = Col. (1) - Col. (2)

Export of water from Well No. 59 and others by C of R,
(Table No. 32, Column 15) is credited to M & D who
produced said water and is excluded from C of R
production (Table 1).

FOR YEARS PRECEDING 1971: Refer to Volume 5, August 1976, Page 1-96.

TABLE NO. 34

MEEKS & DALEY WATER COMPANY
WATER PRODUCTION FROM SAN BERNARDINO BASIN AREA
AND DELIVERIES WITHIN SAN BERNARDINO COUNTY
AND EXPORT TO RIVERSIDE COUNTY
 (Quantities in Acre Feet)

Year	Production in the San Bernardino Basin Area	Deliveries within Colton & Riverside Basins in San Bernardino County	San Bernardino Basin Production Exported to Riverside County
	(1)	(2)	(3)
Adjusted Base Right	7,833	318	7,515
2006	7,515	0	7,515
2007	7,591	0	7,591
2008	4,832	-	4,832
2009	6,345	-	6,345
2010	6,738	-	6,738
2011	7,127	-	7,127
2012	7,117	-	7,117
2013		-	
2014		-	
2015		-	
2016		-	
2017		-	
2018		-	
2019		-	
2020		-	
2021		-	
2022		-	
2023		-	
2024		-	
2025		-	
2026		-	
2027		-	
2028		-	
2029		-	
2030		-	
2031		-	
2032		-	
2033		-	
2034		-	
2035		-	
2036		-	
2037		-	
2038		-	
2039		-	
2040		-	

Column (1) = From Table No. 32, Column (14).
 Column (2) = From Table No. 33, Col. 7.
 Column (3) = Col. (1) - Col. (2)

Export of water from Well No. 59 and others by C of R,
 (Table No. 32, Column 15) is credited to M & D who
 produced said water and is excluded from C of R
 production (Table 1, Line 69d).

Last M&D share sold, water distribution system to Cal Portland failed
 FOR YEARS PRECEDING 1971: Refer to Volume 5, August 1976, Page 1-96.

Volume 5

Tables 35-36

Regents of the University of
California Water production
and distribution

TABLE NO. 35

page 1 of 2

UNIVERSITY OF CALIFORNIA
WATER PRODUCTION FROM BUNKER HILL BASIN IN THE SAN BERNARDINO BASIN AREA
AND EXPORTED TO RIVERSIDE COUNTY
(Quantities in Acre Feet)

Year	Hunt 6	Hunt 8	Hunt 9	Hunt 10	Hunt 11	Total	Export
	1S4W27A11S	1S4W27A07S	1S4W27A08S	1S4W27A09S	1S4W27A10S	Production in Bunker Hill Basin Area	to Riverside County
	3601222	3691241	3691242	3601244	3601245	(6)	(7)
	(1)	(2) ^o	(3) ^o	(4)	(5)		
1971	73	0	0	146	0	219	219
1972	62	0	0	177	0	239	239
1973	50	0	0	189	0	239	239
1974	69	0	0	198	0	267	267
1975	34	0	0	143	2	179	179
1976	8	-	-	225	12	245	245
1977	25	-	-	41	21	87	87
1978	69	-	-	114	0	183	183
1979	29	-	-	54	0	83	83
1980	1	-	-	6	0	7	7
1981	0	-	-	143	0	143	143
1982	20	-	-	6	22	48	48
1983	0	-	-	0	0	0	0
1984	0	-	-	0	0	0	0
1985	0	-	-	0	0	0	0
1986	13	-	-	25	10	48	48
1987	51	-	-	99	45	195	195
1988	58	-	-	55	66	179	179
1989	12	-	-	25	25	62	62
1990	17	-	-	59	19	95	95
1991	5	-	-	12	6	23	23
1992	32	-	-	0	0	32	32
1993	70	-	-	214	252	536	536
1994	147	-	-	245	201	593	593
1995	181	-	-	210	197	588	588
1996	181	-	-	0	264	445	445
1997	113	-	-	207	185	505	505
1998	171	-	-	250	169	590	590
1999	93	-	-	310	183	586	586
2000	97	-	-	405	122	624	624
2001	114	-	-	284	219	617	617
2002	65	-	-	365	188	618	618
2003	43	-	-	493	0	536	536
2004	208	-	-	399	11	618	618
2005	227	-	-	302	7	536	536

Note: No deliveries in Bunker Hill Basin or Riverside North Basin.

^o Abandoned &/or Filed Closed.

FOR YEARS PRECEDING 1971: Refer to Volume 5, August 1976, Page I-100.

No production or deliveries in Colton Basin.

Revised Recordation Numbers issued in 1981.

TABLE NO. 35

UNIVERSITY OF CALIFORNIA
WATER PRODUCTION FROM BUNKER HILL BASIN IN THE SAN BERNARDINO BASIN AREA
AND EXPORTED TO RIVERSIDE COUNTY
 (Quantities in Acre Feet)

Year	Hunt 6 1S4W27A11S 3601222 (1)	Hunt 8 1S4W27A07S 3691241 (2) ^o	Hunt 9 1S4W27A08S 3691242 (3) ^o	Hunt 10 1S4W27A09S 3601244 (4)	Hunt 11 1S4W27A10S 3601245 (5)	Warren #1 Lease 1S4W22H04S 3603924 (5a)	Warren #4 Lease 1S4W22H02S 3603925 (5b)	Cooley H Lease 1S4W11D02S 3603931 (5c)	Total Production in Bunker Hill Basin Area (6)	Export to Riverside County (7)
2006	191	-	-	237	108				536	536
2007	234	-	-	215	87				536	536
2008	74	-	-	92	76	241	53		536	536
2009	0	-	-	0	0	83	88	365	536	536
2010	0	-	-	0	0	55	161	320	536	536
2011	0	-	-	0	0	536	0	0	536	536
2012	0	-	-	0	0	536	0	0	536	536
2013		-	-							
2014		-	-							
2015		-	-							
2016		-	-							
2017		-	-							
2018		-	-							
2019		-	-							
2020		-	-							
2021		-	-							
2022		-	-							
2023		-	-							
2024		-	-							
2025		-	-							
2026		-	-							
2027		-	-							
2028		-	-							
2029		-	-							
2030		-	-							
2031		-	-							
2032		-	-							
2033		-	-							
2034		-	-							
2035		-	-							
2036		-	-							
2037		-	-							
2038		-	-							
2039		-	-							
2040		-	-							

Note: No deliveries in Bunker Hill Basin or Riverside North Basin.

No production or deliveries in Colton Basin.

Revised Recordation Numbers issued in 1981.

^o Abandoned &/or Filed Closed.

FOR YEARS PRECEDING 1971: Refer to Volume 5, August 1976, Page I-100.

TABLE NO. 36

page 1 of 2

UNIVERSITY OF CALIFORNIA
WATER PRODUCTION FROM BUNKER HILL BASIN
IN THE SAN BERNARDINO BASIN AREA
AND EXPORTED TO RIVERSIDE COUNTY

(Quantities in Acre Feet)

Year	Production in San Bernardino Basin Area	Delivery within San Bernardino Co.	S. B. Basin Production Exported to Riverside Co.
	(1)	(2)	(3)
Adjusted Base Right	536	0	536
1971	219	-	219
1972	239	-	239
1973	239	-	239
1974	267	-	267
1975	179	-	179
1976	245	-	245
1977	87	-	87
1978	183	-	183
1979	83	-	83
1980	7	-	7
1981	143	-	143
1982	48	-	48
1983	0	-	0
1984	0	-	0
1985	0	-	0
1986	48	-	48
1987	195	-	195
1988	179	-	179
1989	62	-	62
1990	95	-	95
1991	23	-	23
1992	32	-	32
1993	536	-	536
1994	593	-	593
1995	588	-	588
1996	445	-	445
1997	505	-	505
1998	590	-	590
1999	586	-	586
2000	624	-	624
2001	617	-	617
2002	618	-	618
2003	536	-	536
2004	618	-	618
2005	536	-	536

Column (1) = Table No. 35, Column (6).

Column (2) = No water delivered in San Bernardino County.

Column (3) = Column (1) - Column (2).

FOR YEARS PRECEDING 1971: Refer to Volume 5, August 1976, Page I-102.

TABLE NO. 36

UNIVERSITY OF CALIFORNIA
WATER PRODUCTION FROM BUNKER HILL BASIN
IN THE SAN BERNARDINO BASIN AREA
AND EXPORTED TO RIVERSIDE COUNTY
 (Quantities in Acre Feet)

Year	Production in San Bernardino Basin Area (1)	Delivery within San Bernardino Co. (2)	S. B. Basin Production Exported to Riverside Co. (3)
Adjusted Base Right	536	0	536
2006	536	-	536
2007	536	-	536
2008	536	-	536
2009	536	-	536
2010	536	-	536
2011	536	-	536
2012	536	-	536
2013		-	
2014		-	
2015		-	
2016		-	
2017		-	
2018		-	
2019		-	
2020		-	
2021		-	
2022		-	
2023		-	
2024		-	
2025		-	
2026		-	
2027		-	
2028		-	
2029		-	
2030		-	
2031		-	
2032		-	
2033		-	
2034		-	
2035		-	
2036		-	
2037		-	
2038		-	
2039		-	
2040		-	

Column (1) = Table No. 35, Column (6).
 Column (2) = No water delivered in San Bernardino County.
 Column (3) = Column (1) - Column (2).

FOR YEARS PRECEDING 1971: Refer to Volume 5, August 1976, Page I-102.

Volume 5

Table 36-A	Plaintiffs production and distribution from the San Bernardino Basin Area
Table 36-B	Plaintiffs production in the San Bernardino Basin Area
Table 36-C	Plaintiffs deliveries in the San Bernardino Basin Area
Table 36-D	Plaintiffs deliveries in Colton & Riverside North
Table 36-E	Plaintiffs deliveries outside San Bernardino Valley MWD - Exports to Riverside County

TABLE NO. 36-A

page 1 of 10

EXTRACTIONS BY PLAINTIFF
FROM THE SAN BERNARDINO BASIN AREA
ADJUSTED BASE RIGHT

CLASSIFIED ACCORDING TO SERVICE AREA
(Quantities in Acre Feet)

EXTRACTIONS FROM SAN BERNARDINO BASIN AREA
FOR USE WITHIN AND EXPORT THEREFROM

PLAINTIFFS	Total Extract	Deliveries in the S.B.B.A. Basin	Deliveries in the Colton & Riverside North	Deliveries Outside S.B.V.M.W.D.
	(1)	(2)	(3)	(4)
CITY OF RIVERSIDE City & Riverside Wtr Co.	-	-	-	-
CITY OF RIVERSIDE Gage Canal Co.	-	-	-	-
SUB TOTAL - C of R	52,199	1,427	1,230	49,542
RIVERSIDE HIGHLAND WATER CO	4,294	0	2,449	1,845
MEEKS & DALEY WATER CO. AGUA MANSA WATER CO.	7,833	0	318	7,515
UNIVERSITY OF CALIFORNIA	536	0	0	536
TOTALS	64,862	1,427	3,997	59,438

From Watermaster Annual Report, Table 3

- (1) TOTAL EXTRACTIONS
- (2) DELIVERIES IN SAN BERNARDINO BASIN AREA.
- (3) DELIVERIES IN COLTON & RIVERSIDE BASIN IN SAN BERNARDINO COUNTY.
- (4) DELIVERIES OUTSIDE SAN BERNARDINO VALLEY MUNICIPAL WATER DISTRICT.

TABLE NO. 36-A

EXTRACTIONS BY PLAINTIFF
FROM THE SAN BERNARDINO BASIN AREA
THROUGH THE CURRENT YEAR

CLASSIFIED ACCORDING TO SERVICE AREA
 (Quantities in Acre Feet)

EXTRACTIONS FROM SAN BERNARDINO BASIN AREA FOR USE WITHIN AND EXPORT THEREFROM

PLAINTIFFS	1 9 7 1				1 9 7 2				1 9 7 3				1 9 7 4				1 9 7 5			
	Total Extract	Del. S.B. Basin	Del. Colton & Riv N	Del. Outside SBVMWD	Total Extract	Del. S.B. Basin	Del. Colton & Riv N	Del. Outside SBVMWD	Total Extract	Del. S.B. Basin	Del. Colton & Riv N	Del. Outside SBVMWD	Total Extract	Del. S.B. Basin	Del. Colton & Riv N	Del. Outside SBVMWD	Total Extract	Del. S.B. Basin	Del. Colton & Riv N	Del. Outside SBVMWD
CITY OF RIVERSIDE (a) City & Riverside Wtr Co.	24,939	0	0	24,939	20,474	0	0	20,474	21,493	0	0	21,493	27,420	0	65	27,355	25,248	0	0	25,248
CITY OF RIVERSIDE (b) Gage Canal Co.	28,943	98	669	28,176	25,220	85	547	24,588	21,529	156	512	20,861	15,947	0	485	15,462	22,714	0	498	22,216
SUB TOTAL - C of R	53,882	98	669	53,115	45,694	85	547	45,062	43,022	156	512	42,354	43,367	0	550	42,817	47,962	0	575	47,387
RIVERSIDE HIGHLAND (c) WATER CO	4,012	0	2,385	1,627	4,532	0	2,229	2,303	3,512	0	1,744	1,768	4,088	0	1,979	2,109	4,709	0	1,996	2,713
MEEKS & DALEY WATER CO. (d) AGUA MANSÁ WATER CO.	2,902	0	383	2,519	3,527	0	377	3,150	2,979	0	250	2,729	4,504	0	246	4,258	3,950	0	168	3,782
UNIVERSITY OF CALIFORNIA (e)	219	0	0	219	239	0	0	239	239	0	0	239	267	0	0	267	179	0	0	179
TOTALS	61,015	98	3,440	57,477	53,992	85	3,163	50,744	49,752	156	2,513	47,083	52,226	0	2,781	49,445	56,800	0	2,745	54,055

Total Extract -- TOTAL EXTRACTIONS.
 Del S.B. Basin -- DELIVERIES IN SAN BERNARDINO BASIN AREA.
 Del. Colton & Riv. N. -- DELIVERIES IN COLTON & RIVERSIDE BASIN IN SAN BERNARDINO COUNTY.
 Del. Outside SBVMWD -- DELIVERIES OUTSIDE SAN BERNARDINO VALLEY MUNICIPAL WATER DISTRICT.

- (a) Table 13 - Columns 1, 2, 7, 8.
- (b) Table 18 - Columns 1, 2, 6, 7.
- (c) Table 31A - Columns 4, 1, 2, 3.
- (d) Table 34 - Columns 1, 2, 3.
- (e) Table 36 - Columns 1, 2, 3.

TABLE NO. 36-A

EXTRACTIONS BY PLAINTIFF
FROM THE SAN BERNARDINO BASIN AREA
THROUGH THE CURRENT YEAR

CLASSIFIED ACCORDING TO SERVICE AREA
 (Quantities in Acre Feet)

EXTRACTIONS FROM SAN BERNARDINO BASIN AREA FOR USE WITHIN AND EXPORT THEREFROM

PLAINTIFFS	1 9 7 6				1 9 7 7				1 9 7 8				1 9 7 9				1 9 8 0			
	Total Extract	Del. S.B. Basin	Del. Colton & Riv N	Del. Outside SBVMWD	Total Extract	Del. S.B. Basin	Del. Colton & Riv N	Del. Outside SBVMWD	Total Extract	Del. S.B. Basin	Del. Colton & Riv N	Del. Outside SBVMWD	Total Extract	Del. S.B. Basin	Del. Colton & Riv N	Del. Outside SBVMWD	Total Extract	Del. S.B. Basin	Del. Colton & Riv N	Del. Outside SBVMWD
	(1)	(2)	(3)	(4)	(1)	(2)	(3)	(4)	(1)	(2)	(3)	(4)	(1)	(2)	(3)	(4)	(1)	(2)	(3)	(4)
CITY OF RIVERSIDE (a) City & Riverside Wtr Co.	22,085	0	0	22,085	18,900	0	0	18,900	19,055	0	0	19,055	21,561	0	0	21,561	18,875	0	0	18,875
CITY OF RIVERSIDE (b) Gage Canal Co.	29,289	0	523	28,766	32,099	0	346	31,753	26,329	646	301	25,382	30,816	0	415	30,401	31,881	383	-	31,498
SUB TOTAL - C of R	51,374	0	523	50,851	50,999	0	346	50,653	45,384	646	301	44,437	52,377	0	415	51,962	50,756	383	0	50,373
RIVERSIDE HIGHLAND (c) WATER CO	4,520	0	2,051	2,469	3,583	0	1,820	1,763	1,350	0	1,051	299	3,369	0	1,782	1,587	3,677	0	2,060	1,617
MEEKS & DALEY WATER CO. AGUA MANSÁ WATER CO. (d)	5,393	0	187	5,206	4,220	0	146	4,074	2,254	0	161	2,093	3,930	0	166	3,764	2,333	0	323	2,010
UNIVERSITY OF CALIFORNIA (e)	245	0	0	245	87	0	0	87	183	0	0	183	83	0	0	83	7	0	0	7
TOTALS	61,532	0	2,761	58,771	58,889	0	2,312	56,577	49,171	646	1,513	47,012	59,759	0	2,363	57,396	56,773	383	2,383	54,007

Total Extract -- TOTAL EXTRACTIONS.
 Del S.B. Basin -- DELIVERIES IN SAN BERNARDINO BASIN AREA.
 Del. Colton & Riv. N. -- DELIVERIES IN COLTON & RIVERSIDE BASIN IN SAN BERNARDINO COUNTY.
 Del. Outside SBVMWD -- DELIVERIES OUTSIDE SAN BERNARDINO VALLEY MUNICIPAL WATER DISTRICT.

- (a) Table 13 - Columns 1, 2, 7, 8. These amounts updated during 2011 verification linking all the tables
- (b) Table 18 - Columns 1, 2, 6, 7.
- (c) Table 31A - Columns 4, 1, 2, 3.
- (d) Table 34 - Columns 1, 2, 3.
- (e) Table 36 - Columns 1, 2, 3.

See Report of the Watermaster, Same as Table No. 3, Volume 1a. For Years Preceding 1976: Refer to Volume 5-1975, August 1977, Page 34.

TABLE NO. 36-A

EXTRACTIONS BY PLAINTIFF
FROM THE SAN BERNARDINO BASIN AREA
THROUGH THE CURRENT YEAR

CLASSIFIED ACCORDING TO SERVICE AREA
 (Quantities in Acre Feet)

EXTRACTIONS FROM SAN BERNARDINO BASIN AREA FOR USE WITHIN AND EXPORT THEREFROM

PLAINTIFFS	1 9 8 1				1 9 8 2				1 9 8 3				1 9 8 4				1 9 8 5			
	Total Extract	Del. S.B. Basin	Del. Colton & Riv N	Del. Outside SBVMWD	Total Extract	Del. S.B. Basin	Del. Colton & Riv N	Del. Outside SBVMWD	Total Extract	Del. S.B. Basin	Del. Colton & Riv N	Del. Outside SBVMWD	Total Extract	Del. S.B. Basin	Del. Colton & Riv N	Del. Outside SBVMWD	Total Extract	Del. S.B. Basin	Del. Colton & Riv N	Del. Outside SBVMWD
	(1)	(2)	(3)	(4)	(1)	(2)	(3)	(4)	(1)	(2)	(3)	(4)	(1)	(2)	(3)	(4)	(1)	(2)	(3)	(4)
CITY OF RIVERSIDE (a) City & Riverside Wtr Co.	20,363	0	0	20,363	19,522	146	0	19,376	25,681	144	0	25,537	25,031	9	0	25,022	31,817	0	0	31,817
CITY OF RIVERSIDE (b) Gage Canal Co.	31,794	724	-	31,070	30,077	16	-	30,061	20,383	191	-	20,192	33,875	32	-	33,843	31,256	59	-	31,197
SUB TOTAL - C of R	52,157	724	0	51,433	49,599	162	0	49,437	46,064	335	0	45,729	58,906	41	0	58,865	63,073	59	0	63,014
RIVERSIDE HIGHLAND (c) WATER CO	3,604	0	2,148	1,456	2,795	0	1,776	1,019	3,162	0	2,319	843	4,759	0	2,671	2,088	3,312	0	1,978	1,334
MEEKS & DALEY WATER CO. AGUA MANSÁ WATER CO. (d)	3,092	0	358	2,734	3,716	0	169	3,547	2,651	0	245	2,406	5,165	0	234	4,931	5,385	0	209	5,176
UNIVERSITY OF CALIFORNIA (e)	143	0	0	143	48	0	0	48	0	0	0	0	0	0	0	0	0	0	0	0
TOTALS	58,996	724	2,506	55,766	56,158	162	1,944	54,052	51,877	335	2,565	48,977	68,830	41	2,905	65,884	71,770	59	2,188	69,523

Total Extract -- TOTAL EXTRACTIONS.

Del S.B. Basin -- DELIVERIES IN SAN BERNARDINO BASIN AREA.

Del. Colton & Riv. N. -- DELIVERIES IN COLTON & RIVERSIDE BASIN IN SAN BERNARDINO COUNTY.

Del. Outside SBVMWD -- DELIVERIES OUTSIDE SAN BERNARDINO VALLEY MUNICIPAL WATER DISTRICT.

(a) Table 13 - Columns 1, 2, 7, 8.

(b) Table 18 - Columns 1, 2, 6, 7.

(c) Table 31A - Columns 4, 0, 2, 3. Found this 9 AF while converting this to a linked table, confirmed with 1985 report

(d) Table 34 - Columns 1, 0, 2, 3.

(e) Table 36 - Columns 1, 0, 0, 3.

See Report of the Watermaster, Same as Table No. 3, Volume 1a. For Years Preceding 1976: Refer to Volume 5-1975, August 1977, Page 34.

TABLE NO. 36-A

EXTRACTIONS BY PLAINTIFF
FROM THE SAN BERNARDINO BASIN AREA
THROUGH THE CURRENT YEAR

CLASSIFIED ACCORDING TO SERVICE AREA
 (Quantities in Acre Feet)

EXTRACTIONS FROM SAN BERNARDINO BASIN AREA FOR USE WITHIN AND EXPORT THEREFROM

PLAINTIFFS	1 9 8 6				1 9 8 7				1 9 8 8				1 9 8 9				1 9 9 0			
	Total Extract	Del. S.B. Basin	Del. Colton & Riv N	Del. Outside SBVMWD	Total Extract	Del. S.B. Basin	Del. Colton & Riv N	Del. Outside SBVMWD	Total Extract	Del. S.B. Basin	Del. Colton & Riv N	Del. Outside SBVMWD	Total Extract	Del. S.B. Basin	Del. Colton & Riv N	Del. Outside SBVMWD	Total Extract	Del. S.B. Basin	Del. Colton & Riv N	Del. Outside SBVMWD
	(1)	(2)	(3)	(4)	(1)	(2)	(3)	(4)	(1)	(2)	(3)	(4)	(1)	(2)	(3)	(4)	(1)	(2)	(3)	(4)
CITY OF RIVERSIDE (a) City & Riverside Wtr Co.	25,996	292	0	25,704	25,528	319	0	25,209	26,490	815	0	25,675	21,129	28	0	21,101	20,942	19	0	20,923
CITY OF RIVERSIDE (b) Gage Canal Co.	33,983	145	-	33,838	32,313	15	-	32,298	38,022	0	-	38,022	29,655	0	-	29,655	26,695	0	-	26,695
SUB TOTAL - C of R	59,979	437	0	59,542	57,841	334	0	57,507	64,512	815	0	63,697	50,784	28	0	50,756	47,637	19	0	47,618
RIVERSIDE HIGHLAND (c) WATER CO	4,744	0	2,128	2,616	3,919	0	2,229	1,690	4,775	0	2,229	2,546	4,681	0	1,968	2,713	4,092	0	2,313	1,779
MEEKS & DALEY WATER CO. AGUA MANSÁ WATER CO. (d)	5,570	0	212	5,358	4,914	0	192	4,722	4,966	0	233	4,733	5,392	0	240	5,152	3,851	0	83	3,768
UNIVERSITY OF CALIFORNIA (e)	48	0	0	48	195	0	0	195	179	0	0	179	62	0	0	62	95	0	0	95
TOTALS	70,341	437	2,364	67,540	66,869	334	2,422	64,113	74,432	815	2,461	71,156	60,919	28	2,208	58,683	55,675	19	2,397	53,259

Total Extract -- TOTAL EXTRACTIONS.
 Del S.B. Basin -- DELIVERIES IN SAN BERNARDINO BASIN AREA.
 Del. Colton & Riv. N. -- DELIVERIES IN COLTON & RIVERSIDE BASIN IN SAN BERNARDINO COUNTY.
 Del. Outside SBVMWD -- DELIVERIES OUTSIDE SAN BERNARDINO VALLEY MUNICIPAL WATER DISTRICT.

- (a) Table 13 - Columns 1, 2, 7, 8.
- (b) Table 18 - Columns 1, 2, 6, 7.
- (c) Table 31A - Columns 4, 0, 2, 3.
- (d) Table 34 - Columns 1, 0, 2, 3.
- (e) Table 36 - Columns 1, 0, 0, 3.

See Report of the Watermaster, Same as Table No. 3, Volume 1a. For Years Preceding 1976: Refer to Volume 5-1975, August 1977, Page 34.

TABLE NO. 36-A

EXTRACTIONS BY PLAINTIFF
FROM THE SAN BERNARDINO BASIN AREA
THROUGH THE CURRENT YEAR

CLASSIFIED ACCORDING TO SERVICE AREA
 (Quantities in Acre Feet)

EXTRACTIONS FROM SAN BERNARDINO BASIN AREA FOR USE WITHIN AND EXPORT THEREFROM

PLAINTIFFS	1 9 9 1				1 9 9 2				1 9 9 3				1 9 9 4				1 9 9 5			
	Total Extract	Del. S.B. Basin	Del. Colton & Riv N	Del. Outside SBVMWD	Total Extract	Del. S.B. Basin	Del. Colton & Riv N	Del. Outside SBVMWD	Total Extract	Del. S.B. Basin	Del. Colton & Riv N	Del. Outside SBVMWD	Total Extract	Del. S.B. Basin	Del. Colton & Riv N	Del. Outside SBVMWD	Total Extract	Del. S.B. Basin	Del. Colton & Riv N	Del. Outside SBVMWD
	(1)	(2)	(3)	(4)	(1)	(2)	(3)	(4)	(1)	(2)	(3)	(4)	(1)	(2)	(3)	(4)	(1)	(2)	(3)	(4)
CITY OF RIVERSIDE (a) City & Riverside Wtr Co.	26,133	155	0	25,978	24,783	203	0	24,580	25,567	-108	0	25,675	25,724	7	0	25,717	23,316	1	0	23,315
CITY OF RIVERSIDE (b) Gage Canal Co.	26,776	0	-	26,776	25,456	0	-	25,456	26,439	0	-	26,439	34,723	39	-	34,684	32,076	98	-	31,978
SUB TOTAL - C of R	52,909	155	0	52,754	50,239	203	0	50,036	52,006	-108	0	52,114	60,447	46	0	60,401	55,392	99	0	55,293
RIVERSIDE HIGHLAND (c) WATER CO	3,021	0	1,669	1,352	4,052	0	2,275	1,777	3,241	0	1,777	1,464	4,324	0	2,201	2,123	3,955	0	2,146	1,809
MEEKS & DALEY WATER CO. AGUA MANSÁ WATER CO. (d)	4,426	0	190	4,236	4,100	0	118	3,982	5,013	0	276	4,737	4,525	0	227	4,298	3,560	0	145	3,415
UNIVERSITY OF CALIFORNIA (e)	23	0	0	23	32	0	0	32	536	0	0	536	593	0	0	593	588	0	0	588
TOTALS	60,379	155	1,859	58,365	58,423	203	2,393	55,827	60,796	-108	2,053	58,851	69,889	46	2,428	67,415	63,495	99	2,291	61,105

Total Extract -- TOTAL EXTRACTIONS.
 Del S.B. Basin -- DELIVERIES IN SAN BERNARDINO BASIN AREA.
 Del. Colton & Riv. N. -- DELIVERIES IN COLTON & RIVERSIDE BASIN IN SAN BERNARDINO COUNTY.
 Del. Outside SBVMWD -- DELIVERIES OUTSIDE SAN BERNARDINO VALLEY MUNICIPAL WATER DISTRICT.

- (a) Table 13 - Columns 1, 2, 7, 8.
- (b) Table 18 - Columns 1, 2, 6, 7. corrected during the linking of tables
- (c) Table 31A - Columns 4, 0, 2, 3.
- (d) Table 34 - Columns 1, 0, 2, 3.
- (e) Table 36 - Columns 1, 0, 0, 3.

See Report of the Watermaster, Same as Table No. 3, Volume 1a. For Years Preceding 1976: Refer to Volume 5-1975, August 1977, Page 34.

TABLE NO. 36-A

EXTRACTIONS BY PLAINTIFF
FROM THE SAN BERNARDINO BASIN AREA
THROUGH THE CURRENT YEAR

CLASSIFIED ACCORDING TO SERVICE AREA
 (Quantities in Acre Feet)

EXTRACTIONS FROM SAN BERNARDINO BASIN AREA FOR USE WITHIN AND EXPORT THEREFROM

PLAINTIFFS	1996				1997				1998				1999				2000			
	Total Extract	Del. S.B. Basin	Del. Colton & Riv N	Del. Outside SBVMWD	Total Extract	Del. S.B. Basin	Del. Colton & Riv N	Del. Outside SBVMWD	Total Extract	Del. S.B. Basin	Del. Colton & Riv N	Del. Outside SBVMWD	Total Extract	Del. S.B. Basin	Del. Colton & Riv N	Del. Outside SBVMWD	Total Extract	Del. S.B. Basin	Del. Colton & Riv N	Del. Outside SBVMWD
	(1)	(2)	(3)	(4)	(1)	(2)	(3)	(4)	(1)	(2)	(3)	(4)	(1)	(2)	(3)	(4)	(1)	(2)	(3)	(4)
CITY OF RIVERSIDE (a) City & Riverside Wtr Co.	29,351	268	0	29,083	27,621	486	0	27,135	24,210	0	0	24,210	25,435	0	0	25,435	28,257	0	0	28,257
CITY OF RIVERSIDE (b) Gage Canal Co.	34,031	10	0	34,021	32,317	8	0	32,309	30,207	0	0	30,207	35,707	181	0	35,526	35,215	117	0	35,098
SUB TOTAL - C of R	63,382	278	0	63,104	59,938	494	0	59,444	54,417	0	0	54,417	61,142	181	0	60,961	63,472	117	0	63,355
RIVERSIDE HIGHLAND (c) WATER CO	5,051	0	2,756	2,295	4,939	0	2,656	2,283	3,250	0	1,961	1,289	2,931	0	2,082	849	2,856	0	2,811	45
MEEKS & DALEY WATER CO. AGUA MANSÁ WATER CO. (d)	3,912	0	194	3,718	4,165	0	137	4,028	3,828	0	210	3,618	6,289	0	90	6,199	3,832	0	352	3,480
UNIVERSITY OF CALIFORNIA (e)	445	0	0	445	505	0	0	505	590	0	0	590	586	0	0	586	624	0	0	624
TOTALS	72,790	278	2,951	69,561	69,547	494	2,794	66,259	62,085	0	2,170	59,915	70,948	181	2,172	68,595	70,784	117	3,164	67,503

Total Extract -- TOTAL EXTRACTIONS.
 Del S.B. Basin -- DELIVERIES IN SAN BERNARDINO BASIN AREA.
 Del. Colton & Riv. N. -- DELIVERIES IN COLTON & RIVERSIDE BASIN IN SAN BERNARDINO COUNTY.
 Del. Outside SBVMWD -- DELIVERIES OUTSIDE SAN BERNARDINO VALLEY MUNICIPAL WATER DISTRICT.

- (a) Table 13 - Columns 1, 2, 7, 8.
- (b) Table 18 - Columns 1, 2, 6, 7.
- (c) Table 31A - Columns 4, 0, 2, 3. Excludes High Groundwater Mitigation Project flows in CY 1999 and 2000
- (d) Table 34 - Columns 1, 0, 2, 3.
- (e) Table 36 - Columns 1, 0, 0, 3.

See Report of the Watermaster, Same as Table No. 3, Volume 1a. For Years Preceding 1976: Refer to Volume 5-1975, August 1977, Page 34.

TABLE NO. 36-A

EXTRACTIONS BY PLAINTIFF
FROM THE SAN BERNARDINO BASIN AREA
THROUGH THE CURRENT YEAR

CLASSIFIED ACCORDING TO SERVICE AREA
 (Quantities in Acre Feet)

EXTRACTIONS FROM SAN BERNARDINO BASIN AREA FOR USE WITHIN AND EXPORT THEREFROM

PLAINTIFFS	2001				2002				2003				2004				2005			
	Total Extract	Del. S.B. Basin	Del. Colton & Riv N	Del. Outside SBVMWD	Total Extract	Del. S.B. Basin	Del. Colton & Riv N	Del. Outside SBVMWD	Total Extract	Del. S.B. Basin	Del. Colton & Riv N	Del. Outside SBVMWD	Total Extract	Del. S.B. Basin	Del. Colton & Riv N	Del. Outside SBVMWD	Total Extract	Del. S.B. Basin	Del. Colton & Riv N	Del. Outside SBVMWD
	(1)	(2)	(3)	(4)	(1)	(2)	(3)	(4)	(1)	(2)	(3)	(4)	(1)	(2)	(3)	(4)	(1)	(2)	(3)	(4)
CITY OF RIVERSIDE (a) City & Riverside Wtr Co.	23,042	208	0	22,834	28,604	172	0	28,432	21,836	10	0	21,826	20,525	0	0	20,525	14,966	13	0	14,953
CITY OF RIVERSIDE (b) Gage Canal Co.	36,270	21	0	36,249	36,858	0	0	36,858	32,678	0	0	32,678	32,889	0	0	32,889	29,730	0	0	29,730
SUB TOTAL - C of R	59,312	229	0	59,083	65,462	172	0	65,290	54,514	10	0	54,504	53,414	0	0	53,414	44,696	13	0	44,683
RIVERSIDE HIGHLAND (c) WATER CO	2,665	0	2,543	122	2,399	0	2,271	128	3,881	0	2,036	1,845	1,754	0	1,304	450	3,378	0	1,533	1,845
MEEKS & DALEY WATER CO. AGUA MANSÁ WATER CO. (d)	3,671	0	192	3,479	5,800	0	202	5,598	7,440	0	49	7,391	3,782	0	19	3,763	5,891	0	4	5,887
UNIVERSITY OF CALIFORNIA (e)	617	0	0	617	618	0	0	618	536	0	0	536	618	0	0	618	536	0	0	536
TOTALS	66,265	229	2,735	63,301	74,279	172	2,473	71,634	66,371	10	2,084	64,277	59,568	0	1,322	58,246	54,501	13	1,537	52,951

Total Extract -- TOTAL EXTRACTIONS.

Del S.B. Basin -- DELIVERIES IN SAN BERNARDINO BASIN AREA.

Del. Colton & Riv. N. -- DELIVERIES IN COLTON & RIVERSIDE BASIN IN SAN BERNARDINO COUNTY.

Del. Outside SBVMWD -- DELIVERIES OUTSIDE SAN BERNARDINO VALLEY MUNICIPAL WATER DISTRICT.

(a) Table 13 - Columns 1, 2, 7, 8.

(b) Table 18 - Columns 1, 2, 6, 7.

(c) Table 31A - Columns 4, 0, 2, 3.

(d) Table 34 - Columns 1, 0, 2, 3.

(e) Table 36 - Columns 1, 0, 0, 3.

Line C Excludes High Groundwater Mitigation Project flows in CY 2001
 Excludes High Groundwater Mitigation Project flows in CY 2002
 Excludes High Groundwater Mitigation Project flows in CY 2003

See Report of the Watermaster, Same as Table No. 3, Volume 1a. For Years Preceding 1976: Refer to Volume 5-1975, August 1977, Page 34.

TABLE NO. 36-A

EXTRACTIONS BY PLAINTIFF
FROM THE SAN BERNARDINO BASIN AREA
THROUGH THE CURRENT YEAR

CLASSIFIED ACCORDING TO SERVICE AREA
 (Quantities in Acre Feet)

EXTRACTIONS FROM SAN BERNARDINO BASIN AREA FOR USE WITHIN AND EXPORT THEREFROM

PLAINTIFFS	2006				2007				2008				2009				2010			
	Total Extract	Del. S.B. Basin	Del. Colton & Riv N	Del. Outside SBVMWD	Total Extract	Del. S.B. Basin	Del. Colton & Riv N	Del. Outside SBVMWD	Total Extract	Del. S.B. Basin	Del. Colton & Riv N	Del. Outside SBVMWD	Total Extract	Del. S.B. Basin	Del. Colton & Riv N	Del. Outside SBVMWD	Total Extract	Del. S.B. Basin	Del. Colton & Riv N	Del. Outside SBVMWD
	(1)	(2)	(3)	(4)	(1)	(2)	(3)	(4)	(1)	(2)	(3)	(4)	(1)	(2)	(3)	(4)	(1)	(2)	(3)	(4)
CITY OF RIVERSIDE (a) City & Riverside Wtr Co.	17,653	30	0	17,623	19,694	39	0	19,655	20,835	70	0	20,765	8,511	121	0	8,390	12,333	80	0	12,253
CITY OF RIVERSIDE (b) Gage Canal Co.	31,791	0	0	31,791	32,324	0	0	32,324	32,746	0	0	32,746	34,550	0	0	34,550	33,380	0	0	33,380
SUB TOTAL - C of R	49,444	30	0	49,414	52,018	39	0	51,979	53,581	70	0	53,511	43,061	121	0	42,940	45,713	80	0	45,633
RIVERSIDE HIGHLAND (c) WATER CO	4,149	0	2,304	1,845	3,633	0	1,772	1,861	2,730	0	2,054	676	1,648	0	1,073	575	1,136	0	629	507
MEEKS & DALEY WATER CO. AGUA MANSA WATER CO. (d)	7,515	0	0	7,515	7,591	0	0	7,591	4,832	0	0	4,832	6,345	0	0	6,345	6,738	0	0	6,738
UNIVERSITY OF CALIFORNIA (e)	536	-	-	536	536	-	-	536	536	-	-	536	536	-	-	536	536	-	-	536
TOTALS	61,644	30	2,304	59,310	63,778	39	1,772	61,967	61,679	70	2,054	59,555	51,590	121	1,073	50,396	54,123	80	629	53,414

Total Extract -- TOTAL EXTRACTIONS.
 Del S.B. Basin -- DELIVERIES IN SAN BERNARDINO BASIN AREA.
 Del. Colton & Riv. N. -- DELIVERIES IN COLTON & RIVERSIDE BASIN IN SAN BERNARDINO COUNTY.
 Del. Outside SBVMWD -- DELIVERIES OUTSIDE SAN BERNARDINO VALLEY MUNICIPAL WATER DISTRICT.

- (a) Table 13 - Columns 1, 2, 7, 8. Line C includes City of Riverside Leased production
- (b) Table 18 - Columns 1, 2, 6, 7.
- (c) Table 31A - Columns 4, 0, 2, 3.
- (d) Table 34 - Columns 1, 0, 2, 3.
- (e) Table 36 - Columns 1, 0, 0, 3.

See Report of the Watermaster, Same as Table No. 3, Volume 1a. For Years Preceding 1976: Refer to Volume 5-1975, August 1977, Page 34.

TABLE NO. 36-A

EXTRACTIONS BY PLAINTIFF
FROM THE SAN BERNARDINO BASIN AREA
THROUGH THE CURRENT YEAR

CLASSIFIED ACCORDING TO SERVICE AREA
 (Quantities in Acre Feet)

EXTRACTIONS FROM SAN BERNARDINO BASIN AREA FOR USE WITHIN AND EXPORT THEREFROM

PLAINTIFFS	2011				2012				2013				2014				2015			
	Total Extract	Del. S.B. Basin	Del. Colton & Riv N	Del. Outside SBVMWD	Total Extract	Del. S.B. Basin	Del. Colton & Riv N	Del. Outside SBVMWD	Total Extract	Del. S.B. Basin	Del. Colton & Riv N	Del. Outside SBVMWD	Total Extract	Del. S.B. Basin	Del. Colton & Riv N	Del. Outside SBVMWD	Total Extract	Del. S.B. Basin	Del. Colton & Riv N	Del. Outside SBVMWD
	(1)	(2)	(3)	(4)	(1)	(2)	(3)	(4)	(1)	(2)	(3)	(4)	(1)	(2)	(3)	(4)	(1)	(2)	(3)	(4)
CITY OF RIVERSIDE (a) City & Riverside Wtr Co.	16,697	72	0	16,625	16,384	13	0	16,371												
CITY OF RIVERSIDE (b) Gage Canal Co.	29,791	0	0	29,791	36,122	0	0	36,122												
SUB TOTAL - C of R	46,488	72	0	46,416	52,506	13	0	52,493												
RIVERSIDE HIGHLAND (c) WATER CO	1,655	0	1,087	568	2,135	0	1,523	612												
MEEKS & DALEY WATER CO. AGUA MANSÁ WATER CO. (d)	7,127	0	-	7,127	7,117	0	-	7,117			-				-					-
UNIVERSITY OF CALIFORNIA (e)	536	-	-	536	536	-	-	536			-				-					-
TOTALS	55,806	72	1,087	54,647	62,294	13	1,523	60,758												

Total Extract -- TOTAL EXTRACTIONS.
 Del S.B. Basin -- DELIVERIES IN SAN BERNARDINO BASIN AREA.
 Del. Colton & Riv. N. -- DELIVERIES IN COLTON & RIVERSIDE BASIN IN SAN BERNARDINO COUNTY.
 Del. Outside SBVMWD -- DELIVERIES OUTSIDE SAN BERNARDINO VALLEY MUNICIPAL WATER DISTRICT.

- (a) Table 13 - Columns 1, 2, 7, 8. Line C includes City of Riverside Leased production
- (b) Table 18 - Columns 1, 2, 6, 7.
- (c) Table 31A - Columns 4, 0, 2, 3. Same as Volume 1A, Table No. 3
- (d) Table 34 - Columns 1, 0, 2, 3.
- (e) Table 36 - Columns 1, 0, 0, 3.

For Years Preceding 1976: Refer to Volume 5-1975, August 1977, Page 34.

TABLE NO. 36-B

page 1 of 2

TOTAL PLAINTIFF EXTRACTIONS FROM
SAN BERNARDINO BASIN AREA
 (Quantities in Acre Feet)

EXTRACTING PLAINTIFF

Year	City of Riverside (1)	Gage Canal (2)	Riverside Highland (3)	Meeks & Daley (4)	Univ. of California (5)	Total (6)
Adjusted Right		52,199	4,294	7,833	536	64,862
1971	24,939	28,943	4,012	2,902	219	61,015
1972	20,474	25,220	4,532	3,527	239	53,992
1973	21,493	21,529	3,512	2,979	239	49,752
1974	27,420	15,947	4,088	4,504	267	52,226
1975	25,248	22,714	4,709	3,950	179	56,800
1976	22,085	29,289	4,519	5,393	245	61,531
1977	18,900	32,099	3,583	4,220	87	58,888
1978	19,055	26,329	1,350	2,254	183	49,181
1979	21,561	30,816	3,369	3,930	83	59,759
1980	18,875	31,881	3,677	2,333	7	56,773
1981	20,363	31,794	3,604	3,092	143	58,996
1982	19,522	30,077	2,795	3,716	48	56,158
1983	25,681	20,383	3,161	2,651	0	51,876
1984	25,031	33,875	4,759	5,165	0	68,830
1985	31,817	31,256	3,312	5,385	0	71,770
1986	25,996	33,983	4,744	5,570	48	79,341
1987	25,528	32,313	3,919	4,914	195	66,869
1988	26,490	38,022	4,775	4,966	179	74,432
1989	21,129	29,655	4,681	5,392	62	60,919
1990	20,942	26,695	4,092	3,851	95	55,675
1991	26,133	26,776	3,021	4,426	23	60,379
1992	24,783	25,456	4,052	4,100	32	58,423
1993	25,675	26,439	3,241	5,013	536	60,904
1994	25,724	34,723	4,324	4,525	593	69,889
1995	23,316	32,076	3,955	3,560	588	63,495
1996	29,351	34,031	5,051	3,912	445	72,790
1997	27,621	32,317	4,939	4,165	505	69,547
1998	24,210	30,207	3,250	3,828	590	62,085
1999	25,435	35,707	2,931	6,289	586	70,948 *
2000	28,257	35,215	2,856	3,832	624	70,784 *
2001	23,042	36,270	2,665	3,671	617	66,265 *
2002	28,604	36,858	2,399	5,800	618	74,279 *
2003	21,836	32,678	3,881	7,440	536	66,371 *
2004	20,525	32,889	1,754	3,782	618	59,568
2005	14,966	29,730	3,378	5,891	536	54,501

From Table No. 36-A Column 1.

Adjusted Right from Annual Report Table 3

Same as Table 4, Vol. 1A

* Excludes High Groundwater Mitigation Project Flows

FOR YEARS PRECEDING 1971: Refer to Volume 5, August 1976, Page 1-109.

TABLE NO. 36-B

TOTAL PLAINTIFF EXTRACTIONS FROM
SAN BERNARDINO BASIN AREA
 (Quantities in Acre Feet)

EXTRACTING PLAINTIFF

Year	City of Riverside	Gage Canal	Riverside Highland	Meeks & Daley	Univ. of California	Total
	(1)	(2)	(3)	(4)	(5)	(6)
Adjusted Right	-	52,199	4,294	7,833	536	64,862
2006	17,653	31,791	4,149	7,515	536	61,644
2007	19,694	32,324	3,633	7,591	536	63,778
2008	20,835	32,746	2,730	4,832	536	61,679
2009	8,511	34,550	1,648	6,345	536	51,590
2010	12,333	33,380	1,136	6,738	536	54,123
2011	16,697	29,791	1,655	7,127	536	55,806
2012	16,384	36,122	2,135	7,117	536	62,294
2013						
2014						
2015						
2016						
2017						
2018						
2019						
2020						
2021						
2022						
2023						
2024						
2025						
2026						
2027						
2028						
2029						
2030						
2031						
2032						
2033						
2034						
2035						
2036						
2037						
2038						
2039						
2040						

Column (1) from Table 1, Line 34
 Column (2) from Table 17, Column 5
 Column (3) from Table 19, Column 16
 Column (4) from Table 34, Column 1
 Column (5) from Table 35, Column 6
 Adjusted Right from Annual Report Table 3
 Previous tables were from from Table No. 36-A Column 1.
 Same as Volume 1A, Table 4

* Excludes High Groundwater Mitigation Project Flows
 FOR YEARS PRECEDING 1971: Refer to Volume 5, August 1976, Page 1-109.

TABLE NO. 36-C

TOTAL PLAINTIFF EXTRACTIONS FROM
SAN BERNARDINO BASIN AREA
DELIVERIES IN SAN BERNARDINO BASIN AREA
 (Quantities in Acre Feet)

EXTRACTING PLAINTIFF

Year	City of Riverside	Gage Canal	Riverside Highland	Meeks & Daley	Univ. of California	Total
	(1)	(2)	(3)	(4)	(5)	(6)
Adjusted Right		1,427	0	0	0	1,427
1971	0	98	0	0	0	98
1972	0	85	0	0	0	85
1973	0	156	0	0	0	156
1974	0	0	0	0	0	0
1975	0	0	0	0	0	0
1976	0	0	0	0	0	0
1977	0	0	0	0	0	0
1978	0	646	0	0	0	646
1979	0	0	0	0	0	0
1980	0	383	0	0	0	383
1981	0	724	0	0	0	724
1982	146	16	0	0	0	162
1983	144	191	0	0	0	335
1984	0	32	0	0	0	32
1985	0	59	0	0	0	59
1986	292	145	0	0	0	437
1987	319	15	0	0	0	334
1988	815	0	0	0	0	815
1989	28	0	0	0	0	28
1990	19	0	0	0	0	19
1991	155	0	0	0	0	155
1992	203	0	0	0	0	203
1993	-108	0	0	0	0	-108
1994	7	39	0	0	0	46
1995	1	98	0	0	0	99
1996	268	10	0	0	0	278
1997	486	8	0	0	0	494
1998	0	0	0	0	0	0
1999	0	181	0	0	0	181
2000	0	117	0	0	0	117
2001	208	21	0	0	0	229
2002	172	0	0	0	0	172
2003	10	0	0	0	0	10
2004	0	0	0	0	0	0
2005	13	0	0	0	0	13

From Table No. 36-A Column 2.

(Same as Volume 1A, Table 5)

Column (1) = Table 13, Column 2

Column (2) = Table 18, Column 2 - no active delivery points

Column (3) = Table 19, Column 16 - no historic deliveries

Column (4) = Table 34, Column 1 - no historic deliveries

Column (5) = Table 35, Column 6 - no historic deliveries

FOR YEARS PRECEDING 1971: Refer to Volume 5, August 1976, Page 1-112.

TABLE NO. 36-C

TOTAL PLAINTIFF EXTRACTIONS FROM
SAN BERNARDINO BASIN AREA
DELIVERIES IN SAN BERNARDINO BASIN AREA
 (Quantities in Acre Feet)

EXTRACTING PLAINTIFF

Year	City of Riverside	Gage Canal	Riverside Highland	Meeks & Daley	Univ. of California	Total
	(1)	(2)	(3)	(4)	(5)	(6)
Adjusted Right	0	1,427	0	0	0	1,427
2006	30	-	-	-	-	30
2007	39	-	-	-	-	39
2008	70	-	-	-	-	70
2009	121	-	-	-	-	121
2010	80	-	-	-	-	80
2011	72	-	-	-	-	72
2012	13	-	-	-	-	13
2013		-	-	-	-	
2014		-	-	-	-	
2015		-	-	-	-	
2016		-	-	-	-	
2017		-	-	-	-	
2018		-	-	-	-	
2019		-	-	-	-	
2020		-	-	-	-	
2021		-	-	-	-	
2022		-	-	-	-	
2023		-	-	-	-	
2024		-	-	-	-	
2025		-	-	-	-	
2026		-	-	-	-	
2027		-	-	-	-	
2028		-	-	-	-	
2029		-	-	-	-	
2030		-	-	-	-	
2031		-	-	-	-	
2032		-	-	-	-	
2033		-	-	-	-	
2034		-	-	-	-	
2035		-	-	-	-	
2036		-	-	-	-	
2037		-	-	-	-	
2038		-	-	-	-	
2039		-	-	-	-	
2040		-	-	-	-	

From Table No. 36-A Column 2.

(Same as Volume 1A, Table 5)

Column (1) = Table 13, Column 2

Column (2) = Table 18, Column 2 - no active delivery points

Column (3) = Table 19, Column 16 - no historic deliveries

Column (4) = Table 34, Column 1 - no historic deliveries

Column (5) = Table 35, Column 6 - no historic deliveries

FOR YEARS PRECEDING 1971: Refer to Volume 5, August 1976, Page 1-112.

TABLE NO. 36-D

page 1 of 2

TOTAL PLAINTIFF EXTRACTIONS FROM
SAN BERNARDINO BASIN AREA
DELIVERIES IN COLTON & RIVERSIDE BASINS IN SAN BERNARDINO COUNTY
(Quantities in Acre Feet)

EXTRACTING PLAINTIFF

Year	City of Riverside	Gage Canal	Riverside Highland	Meeks & Daley	Univ. of California	Total
	(1)	(2)	(3)	(4)	(5)	(6)
Adjusted Right		1,230	2,449	318	0	3,997
1971	0	669	2,388	383	0	3,440
1972	0	547	2,239	377	0	3,163
1973	0	512	1,751	250	0	2,513
1974	65	485	1,985	246	0	2,781
1975	0	575	2,002	168	0	2,745
1976	0	523	2,050	182	0	2,755
1977	0	346	1,820	146	0	2,312
1978	0	301	1,051	161	0	1,513
1979	0	415	1,781	166	0	2,362
1980	0	0	2,060	323	0	2,383
1981	0	0	2,151	358	0	2,509
1982	0	0	1,775	169	0	1,944
1983	0	0	2,318	245	0	2,563
1984	0	0	2,671	233	0	2,904
1985	0	0	1,978	210	0	2,188
1986	0	0	2,130	234	0	2,364
1987	0	0	2,229	193	0	2,422
1988	0	0	2,229	233	0	2,462
1989	0	0	1,968	240	0	2,208
1990	0	0	2,313	83	0	2,396
1991	0	0	1,669	190	0	1,859
1992	0	0	2,275	118	0	2,393
1993	0	0	1,777	276	0	2,053
1994	0	0	2,201	227	0	2,428
1995	0	0	2,146	145	0	2,291
1996	0	0	2,756	194	0	2,951
1997	0	0	2,656	137	0	2,794
1998	0	0	1,961	210	0	2,170
1999	0	0	2,082	90	0	2,172
2000	0	0	2,811	352	0	3,164
2001	0	0	2,543	192	0	2,735
2002	0	0	2,271	202	0	2,473
2003	0	0	2,036	49	0	2,084
2004	0	0	1,304	19	0	1,322
2005	0	0	1,533	4	0	1,537

From Table No. 36-A Column 3.

Same as Volume 1A, Table 6

FOR YEARS PRECEDING 1971: Refer to Volume 5, August 1976, Page 1-113.

Adjusted Right from Annual Report, Table 3

TABLE NO. 36-D

TOTAL PLAINTIFF EXTRACTIONS FROM
SAN BERNARDINO BASIN AREA
DELIVERIES IN COLTON & RIVERSIDE BASINS IN SAN BERNARDINO COUNTY
 (Quantities in Acre Feet)

EXTRACTING PLAINTIFF

Year	City of Riverside	Gage Canal	Riverside Highland	Meeks & Daley	Univ. of California	Total
	(1)	(2)	(3)	(4)	(5)	(6)
Adjusted Right		1,230	2,449	318	0	3,997
2006	0	-	2,304	0	-	2,304
2007	0	-	1,772	0	-	1,772
2008	0	-	2,054	-	-	2,054
2009	0	-	1,073	-	-	1,073
2010	0	-	629	-	-	629
2011	0	-	1,087	-	-	1,087
2012	0	-	1,523	-	-	1,523
2013		-		-	-	
2014		-		-	-	
2015		-		-	-	
2016		-		-	-	
2017		-		-	-	
2018		-		-	-	
2019		-		-	-	
2020		-		-	-	
2021		-		-	-	
2022		-		-	-	
2023		-		-	-	
2024		-		-	-	
2025		-		-	-	
2026		-		-	-	
2027		-		-	-	
2028		-		-	-	
2029		-		-	-	
2030		-		-	-	
2031		-		-	-	
2032		-		-	-	
2033		-		-	-	
2034		-		-	-	
2035		-		-	-	
2036		-		-	-	
2037		-		-	-	
2038		-		-	-	
2039		-		-	-	
2040		-		-	-	

From Table No. 36-A Column 3. Same as Volume 1A, Table 6
 FOR YEARS PRECEDING 1971: Refer to Volume 5, August 1976, Page 1-113.
 Column (1) = Table 13, Column 7
 Column (2) = Table 18, Column 6 - no active delivery points
 Column (3) = Table 23R, Sheet 2, Column 6
 Column (4) = Table 33, Column 6 - no active delivery points
 Column (5) = Table 36, Column 2 - no historic deliveries
 Adjusted Right from Annual Report, Table 3

TABLE NO. 36-E

page 1 of 2

TOTAL PLAINTIFF EXTRACTIONS FROM
SAN BERNARDINO BASIN AREA
DELIVERIES OUTSIDE SAN BERNARDINO VALLEY
(Quantities in Acre Feet)

EXTRACTING PLAINTIFF

Year	City of Riverside (1)	Gage Canal (2)	Riverside Highland (3)	Meeks & Daley (4)	Univ. of California (5)	Total (6)
Adjusted Right		49,542	1,845	7,515	536	59,438
1971	24,939	28,176	1,624	2,519	219	57,477
1972	20,474	24,588	2,293	3,150	239	50,744
1973	21,493	20,861	1,761	2,729	239	47,083
1974	27,355	15,462	2,103	4,258	267	49,445
1975	25,248	22,139	2,707	3,783	179	54,056
1976	22,085	28,766	2,469	5,211	245	58,776
1977	18,900	31,753	1,763	4,074	87	56,577
1978	19,055	25,382	299	2,093	183	47,012
1979	21,561	30,401	1,588	3,764	83	57,397
1980	18,875	31,498	1,617	2,010	7	54,007
1981	20,363	31,070	1,453	2,734	143	55,763
1982	19,376	30,061	1,020	3,547	48	54,052
1983	25,537	20,192	843	2,406	0	48,978
1984	25,031	33,843	2,088	4,932	0	65,894
1985	31,817	31,197	1,334	5,175	0	69,523
1986	25,704	33,838	2,614	5,336	48	67,540
1987	25,209	32,298	1,690	4,721	195	64,113
1988	25,675	38,022	2,546	4,733	179	71,155
1989	21,101	29,655	2,713	5,152	62	58,683
1990	20,923	26,695	1,779	3,768	95	53,260
1991	25,978	26,776	1,352	4,236	23	58,365
1992	24,580	25,456	1,777	3,982	32	55,827
1993	25,783	26,439	1,464	4,737	536	58,959
1994	25,717	34,684	2,123	4,298	593	67,415
1995	23,315	31,978	1,809	3,415	588	61,105
1996	29,083	34,021	2,295	3,718	445	69,561
1997	27,135	32,309	2,283	4,028	505	66,259
1998	24,210	30,207	1,289	3,618	590	59,915
1999	25,435	35,526	849	6,199	586	68,595
2000	28,257	35,098	45	3,480	624	67,503
2001	22,834	36,249	122	3,479	617	63,301
2002	28,432	36,858	128	5,598	618	71,634
2003	21,826	32,678	1,845	7,391	536	64,277
2004	20,525	32,889	450	3,763	618	58,246
2005	14,953	29,730	1,845	5,887	536	52,951

From Table No. 36-A Column 4.

Same as Volume 1A, Table 7

FOR YEARS PRECEDING 1971: Refer to Volume 5, August 1976, Page 1-115.

Adjusted Right from Annual Report, Table 3

TABLE NO. 36-E

TOTAL PLAINTIFF EXTRACTIIONS FROM
SAN BERNARDINO BASIN AREA
DELIVERIES OUTSIDE SAN BERNARDINO VALLEY
 (Quantities in Acre Feet)

EXTRACTING PLAINTIFF

Year	City of Riverside	Gage Canal	Riverside Highland	Meeks & Daley	Univ. of California	Total
	(1)	(2)	(3)	(4)	(5)	(6)
Adjusted Right		49,542	1,845	7,515	536	59,438
2006	17,623	31,791	1,845	7,515	536	59,310
2007	19,655	32,324	1,861	7,591	536	61,967
2008	20,765	32,746	676	4,832	536	59,555
2009	8,390	34,550	575	6,345	536	50,396
2010	12,253	33,380	507	6,738	536	53,414
2011	16,625	29,791	568	7,127	536	54,647
2012	16,371	36,122	612	7,117	536	60,758
2013						
2014						
2015						
2016						
2017						
2018						
2019						
2020						
2021						
2022						
2023						
2024						
2025						
2026						
2027						
2028						
2029						
2030						
2031						
2032						
2033						
2034						
2035						
2036						
2037						
2038						
2039						
2040						

Previous years from Table No. 36-A, Column 4. Same as Volume 1A, Table 7

FOR YEARS PRECEDING 1971: Refer to Volume 5, August 1976, Page 1-115.

Column (1) = Table 13, Column 5

Column (2) = Table 18, Column 7

Column (3) = Table 31A, Column 3

Column (4) = Table 34, Column 3

Column (5) = Table 36, Column 3

Adjusted Right from Annual Report, Table 3

Volume 5

Tables 37-39A

Colton Basin production and
deliveries by both Riverside
and San Bernardino Entities

TABLE NO. 37

RIVERSIDE ENTITIES
PRODUCTION AND DELIVERY FROM COLTON BASIN AREA
FOR AVERAGE OF FIVE-YEAR PERIOD ENDING WITH 1963
FOR USE WITHIN SAN BERNARDINO COUNTY & RIVERSIDE COUNTY

(Quantities in Acre Feet)
 -- updated through 1970 --

JUDGMENT QUANTITIES
AS VERIFIED
 APPENDIX D
 TABLE D-2
 5-YEAR
 AVERAGE

Line #	RIVERSIDE ENTITIES	1959	1960	1961	1962	1963	TOTAL	AVERAGE	
1	City of Riverside, Irrigation & Domestic								See Chapter 1, City of Riverside, Table 2
2	Colton Basin Area Production	2,871	2,165	3,486	1,835	1,807	12,164	2,433	Sheet 2, Line 7
3	Delivery to Edison Highgrove Stream Plant	41	28	0	0	7	76	15	See Chapter 1, City of Riverside, Table 10, Column 17
4	Colton Production Exported to Riverside Co.	2,830	2,137	3,486	1,835	1,800	12,088	2,418	See Chapter 1, City of Riverside, Table 11, Column 6
5									
6	Meeks & Daley Water Company								See Chapter 1, Meeks & Daley, Table 32
7	Colton Basin Area Production	2,168	23	465	1,185	339	4,180	836	Sheet 2, Line 21
8	Delivery in the Vicinity of Colton	88	1	18	57	13	177	35	See Chapter 1, Meeks & Daley, Table 33 Column 8
9	Colton Production Exported to Riverside Co.	2,080	22	447	1,128	326	4,003	801	See Chapter 1, City of Riverside, Table 11, Column 10
10									
11	Riverside Highland Water Company								
12	Colton Basin Area Production	211	126	357	280	163	1,137	227	See Chapter 1, R.H.W. Co., Table 20, Total Production
13	Delivery North of the County Line	50	27	107	96	47	327	65	See Chapter 1, R.H.W. Co., Table 31 Column 6
14	Colton Production Exported to Riverside Co.	161	99	250	184	116	810	162	See Chapter 1, R.H.W. Co., Table 31 column 15
* 15	Reche Canyon Mutual Water Company								
	Colton Basin Area Production								
	Delivery North of the County Line								
	Colton Production Exported to Riverside Co.	0	0	0	0	0	0	0	
16									Judgment Quantities
17									Appendix D, Table D2
18	City of Riverside	41	28	0	0	7	76	15	15
19	Meek & Daley	88	1	18	57	13	177	35	35
20	Riverside Highlands	50	27	107	96	47	327	65	97
	Reche Canyon Mutual Water Company	0	0	0	0	0	0	0	0
21	Total	179	56	125	153	67	580	115	147
22									
23									
24									
25	City of Riverside	2,830	2,137	3,486	1,835	1,800	12,088	2,418	2,418
26	Meek & Daley	2,080	22	447	1,128	326	4,003	801	801
27	Riverside Highlands	161	99	250	184	116	810	162	130
28	Reche Canyon Mutual Water Company	0	0	0	0	0	0	0	0
29	Total	5,071	2,258	4,183	3,147	2,242	16,901	3,381	3,349
30	Total Prod. by Riverside Entities, Lns 24 + 29	5,250	2,314	4,308	3,300	2,309	17,481	3,496	3,496

* Reche Canyon Mutual Water Company not identified until after Base Period work completed

TABLE NO. 37

RIVERSIDE ENTITIES
PRODUCTION AND DELIVERY FROM COLTON BASIN AREA
FOR USE WITHIN SAN BERNARDINO COUNTY & RIVERSIDE COUNTY
 (Quantities in Acre Feet)

Line #	RIVERSIDE ENTITIES	1971	1972	1973	1974	1975	TOTAL	5-YEAR AVERAGE	
1	City of Riverside, Irrigation & Domestic								
2	Colton Basin Area Production	2,696	2,521	101	1,386	2,545	9,249	1,850	Table No. 2, Line 7
3	Delivery to Edison Highgrove Stream Plant	0	0	0	0	0	0	0	Table No. 10, Column (17)
4	Colton Production Exported to Riverside Co.	2,696	2,521	101	1,386	2,545	9,249	1,850	Ln 2 - Ln 3
5									
6	Meeks & Daley Water Company								
7	Colton Basin Area Production	0	0	484	0	1,350	1,834	367	Table No. 32, Column (17)
8	Delivery in the Vicinity of Colton	0	0	41	0	98	139	28	Table No. 33, Column (8)
9	Colton Production Exported to Riverside Co.	0	0	443	0	1,252	1,695	339	Table No. 33, Column (10)
10									
11	Riverside Highland Water Company								
12	Colton Basin Area Production	256	285	212	282	300	1,335	267	Table No. 20, Column (4)
13	Delivery North of the County Line	248	271	206	273	291	1,289	258	Table .No.31, Col(6)
14	Colton Production Exported to Riverside Co.	8	14	6	9	9	46	9	Table .No.31, Col(15)
15									
16	Reche Canyon Mutual Water Company								See Vol. 2, Reche Cyn M.W.C.
17	Colton Basin Area Production	73	76	65	69	67	350	70	Vol. 2, Table 3
18	Delivery North of the County Line	-	-	-	-	-	-	-	Production & use only in Riv Co.
19	Colton Production Exported to Riverside Co.	73	76	65	69	67	350	70	Production & use only in Riv Co.
<u>Summary of Colton Basin Water Used in San Bernardino County</u>									
20	City of Riverside	Line 3	0	0	0	0	0	0	
21	Meek & Daley	Line 8	0	0	41	0	98	139	28
22	Riverside Highlands	Line 13	248	271	206	273	291	1,289	258
23	Reche Canyon Mutual Water Company	Line 18	-	-	-	-	-	-	-
24	Total		248	271	247	273	389	1,428	286
<u>Summary of Colton Basin Water Exported to Riverside County</u>									
25	City of Riverside	Line 4	2,696	2,521	101	1,386	2,545	9,249	1,850
26	Meek & Daley	Line 9	0	0	443	0	1,252	1,695	339
27	Riverside Highlands	Line 14	8	14	6	9	9	46	9
28	Reche Canyon Mutual Water Company	Line 19	73	76	65	69	67	350	70
29	Total		2,777	2,611	615	1,464	3,873	11,340	2,268
30	Total Prod. by Riverside Entities, Lns 24 + 29		3,025	2,882	862	1,737	4,262	12,768	2,554

TABLE NO. 37

RIVERSIDE ENTITIES
PRODUCTION AND DELIVERY FROM COLTON BASIN AREA
FOR USE WITHIN SAN BERNARDINO COUNTY & RIVERSIDE COUNTY
 (Quantities in Acre Feet)

Line #	RIVERSIDE ENTITIES	1976	1977	1978	1979	1980	1981	1982	1983	1984	1985	
1	City of Riverside, Irrigation & Domestic											
2	Colton Basin Area Production	853	295	464	5	5	77	57	0	0	695	Table No. 2, Line 9
3	Delivery to Edison Highgrove Stream Plant	0	0	0	0	0	0	-	-	-	-	Table No. 10, Column (17)
4	Colton Production Exported to Riverside Co.	853	295	464	5	5	77	57	0	0	695	Ln 2 - Ln 3
5												
6	Meeks & Daley Water Company											
7	Colton Basin Area Production	1,860	2,018	422	1,698	0	0	910	50	1,383	1,554	Table No. 32, Column (17)
8	Delivery in the Vicinity of Colton	100	125	78	104	0	0	68	37	125	113	Table No. 33, Column (8)
9	Colton Production Exported to Riverside Co.	1,760	1,893	344	1,594	0	0	842	13	1,258	1,441	Table No. 33, Column (10)
10												
11	Riverside Highland Water Company											
12	Colton Basin Area Production	170	332	270	191	0	0	0	0	83	675	Table No. 20, Column (4)
13	Delivery North of the County Line	165	322	260	184	0	0	0	0	80	651	Table No.31, Col(6)
14	Colton Production Exported to Riverside Co.	5	10	10	7	0	0	0	0	3	24	Table No.31, Col(15)
15												
16	Reche Canyon Mutual Water Company											See Vol. 2, Reche Cyn M.W.C.
17	Colton Basin Area Production	70	71	77	76	71	96	82	82	80	83	Volume 2, Table No. 3
18	Delivery North of the County Line	-	-	-	-	-	-	-	-	-	-	Production & use only in Riv Co.
19	Colton Production Exported to Riverside Co.	70	71	77	76	71	96	82	82	80	83	Production & use only in Riv Co.

Summary of Colton Basin Water Used in San Bernardino County

20	City of Riverside	Line 3	0	0	0	0	0	-	-	-	-	
21	Meek & Daley	Line 8	100	125	78	104	0	68	37	125	113	
22	Riverside Highlands	Line 13	165	322	260	184	0	0	0	80	651	
23	Reche Canyon Mutual Water Company	Line 18	-	-	-	-	-	-	-	-	-	
24	Total		265	447	338	288	0	68	37	205	764	

Summary of Colton Basin Water Exported to Riverside County

25	City of Riverside	Line 4	853	295	464	5	5	77	57	0	0	695
26	Meek & Daley	Line 9	1760	1893	344	1594	0	842	13	1258	1441	
27	Riverside Highlands	Line 14	5	10	10	7	0	0	0	3	24	
28	Reche Canyon Mutual Water Company	Line 19	70	71	77	76	71	96	82	80	83	
29	Total		2,688	2,269	895	1,682	76	173	95	1,341	2,243	
30	Total Prod. by Riverside Entities, Lns 24 + 29		2,953	2,716	1,233	1,970	76	173	1,049	132	1,546	3,007

TABLE NO. 37

RIVERSIDE ENTITIES
PRODUCTION AND DELIVERY FROM COLTON BASIN AREA
FOR USE WITHIN SAN BERNARDINO COUNTY & RIVERSIDE COUNTY
(Quantities in Acre Feet)

Line #	RIVERSIDE ENTITIES	1986	1987	1988	1989	1990	1991	1992	1993	1994	1995	
1	City of Riverside, Irrigation & Domestic											
2	Colton Basin Area Production	0	0	0	519	131	428	307	311	466	171	Table 2, Line 9
3	Delivery to Edison Highgrove Stream Plant	-	-	-	-	-	-	-	-	-	-	Table 10, Column (17)
4	Colton Production Exported to Riverside Co.	0	0	0	519	131	428	307	311	466	171	Ln 2 - Ln 3
5												
6	Meeks & Daley Water Company											
7	Colton Basin Area Production	1,575	1,560	1,754	1,538	1,691	1,530	1,209	0	586	344	Table 32, Column (17)
8	Delivery in the Vicinity of Colton	115	114	150	157	306	204	176	0	95	126	Table 33, Column (8)
9	Colton Production Exported to Riverside Co.	1,460	1,446	1,604	1,381	1,385	1,326	1,033	0	491	218	Table 33, Column (10)
10												
11	Riverside Highland Water Company											
12	Colton Basin Area Production	721	471	256	158	109	4	91	0	0	0	Table 20, Column (4)
13	Delivery North of the County Line	691	451	242	142	62	2	51	0	0	0	T 31, Col (6) after 1989 T 23R, pg 2, Col (8)
14	Colton Production Exported to Riverside Co.	30	20	14	16	47	2	40	0	0	0	T 31, Col (15 after 1989 T 23R, pg 2, Col (9))
15												
16	Reche Canyon Mutual Water Company											See Vol. 2, Reche Cyn M.W.C.
17	Colton Basin Area Production	88	90	89	89	89	79	75	85	109	100	Vol. 2, Table 3
18	Delivery North of the County Line	-	-	-	-	-	-	-	-	-	-	Production & use only in Riv Co.
19	Colton Production Exported to Riverside Co.	88	90	89	89	89	79	75	85	109	100	Production & use only in Riv Co.
<u>Summary of Colton Basin Water Used in San Bernardino County</u>												
20	City of Riverside	Line 3	-	-	-	-	-	-	-	-	-	-
21	Meek & Daley	Line 8	115	114	150	157	306	204	176	0	95	126
22	Riverside Highlands	Line 13	691	451	242	142	62	2	51	0	0	0
23	Reche Canyon Mutual Water Company	Line 18	-	-	-	-	-	-	-	-	-	-
24	Total		806	565	392	299	368	206	227	0	95	126
<u>Summary of Colton Basin Water Exported to Riverside County</u>												
25	City of Riverside	Line 4	0	0	0	519	131	428	307	311	466	171
26	Meek & Daley	Line 9	1,460	1,446	1,604	1,381	1,385	1,326	1,033	0	491	218
27	Riverside Highlands	Line 14	30	20	14	16	47	2	40	0	0	0
28	Reche Canyon Mutual Water Company	Line 19	88	90	89	89	89	79	75	85	109	100
29	Total		1,578	1,556	1,707	2,005	1,652	1,835	1,455	396	1,066	489
30	Total Prod. by Riverside Entities, Lns 24 + 29		2,384	2,121	2,099	2,304	2,020	2,041	1,682	396	1,161	615

TABLE NO. 37

RIVERSIDE ENTITIES
PRODUCTION AND DELIVERY FROM COLTON BASIN AREA
FOR USE WITHIN SAN BERNARDINO COUNTY & RIVERSIDE COUNTY
 (Quantities in Acre Feet)

Line #	RIVERSIDE ENTITIES	1996	1997	1998	1999	2000	2001	2002	2003	2004	2005	
1	City of Riverside, Irrigation & Domestic											
2	Colton Basin Area Production	208	633	142	7	128	0	0	171	0	0	Table 2, Line 9
3	Delivery to Edison Highgrove Stream Plant	-	-	-	-	-	-	-	-	-	-	Table 10, Column (17)
4	Colton Production Exported to Riverside Co.	208	633	142	7	128	0	0	171	0	0	Ln 2 - Ln 3
5												
6	Meeks & Daley Water Company											
7	Colton Basin Area Production	362	484	88	1,066	102	285	1,322	844	120	30	Table 32, Column (17)
8	Delivery in the Vicinity of Colton	78	81	32	222	73	168	116	18	7	3	Table 33, Column (8)
9	Colton Production Exported to Riverside Co.	284	403	56	844	29	117	1,206	826	113	27	Table 33, Column (10)
10												
11	Riverside Highland Water Company											
12	Colton Basin Area Production	0	0	0	0	0	0	0	0	0	0	Table 20, Column (4)
13	Delivery North of the County Line	0	0	0	0	0	0	0	0	0	0	After 1989 T 23R, pg 2, Col (8)
14	Colton Production Exported to Riverside Co.	0	0	0	0	0	0	0	0	0	0	After 1989 T 23R, pg 2, Col (9)
15												
16	Reche Canyon Mutual Water Company											See Vol. 2, Reche Cyn M.W.C.
17	Colton Basin Area Production	85	105	53	61	56	48	73	65	59	57	Vol. 2, Table3
18	Delivery North of the County Line	-	-	-	-	-	-	-	-	-	-	Production & use only in Riv Co.
19	Colton Production Exported to Riverside Co.	85	105	53	61	56	48	73	65	59	57	Production & use only in Riv Co.
<u>Summary of Colton Basin Water Used in San Bernardino County</u>												
20	City of Riverside	Line 3	-	-	-	-	-	-	-	-	-	-
21	Meek & Daley	Line 8	78	81	32	222	73	168	116	18	7	3
22	Riverside Highlands	Line 13	0	0	0	0	0	0	0	0	0	0
23	Reche Canyon Mutual Water Company	Line 18	-	-	-	-	-	-	-	-	-	-
24	Total		78	81	32	222	73	168	116	18	7	3
<u>Summary of Colton Basin Water Exported to Riverside County</u>												
25	City of Riverside	Line 4	208	633	142	7	128	0	0	171	0	0
26	Meek & Daley	Line 9	284	403	56	844	29	117	1,206	826	113	27
27	Riverside Highlands	Line 14	0	0	0	0	0	0	0	0	0	0
28	Reche Canyon Mutual Water Company	Line 19	85	105	53	61	56	48	73	65	59	57
29	Total		577	1,141	251	912	213	165	1,279	1,062	172	84
30	Total Prod. by Riverside Entities, Lns 24 + 29		655	1,222	283	1,134	286	333	1,395	1,080	179	87

TABLE NO. 37

RIVERSIDE ENTITIES
PRODUCTION AND DELIVERY FROM COLTON BASIN AREA
FOR USE WITHIN SAN BERNARDINO COUNTY & RIVERSIDE COUNTY
 (Quantities in Acre Feet)

Line #	RIVERSIDE ENTITIES	2006	2007	2008	2009	2010	2011	2012	2013	2014	2015	
1	City of Riverside, Irrigation & Domestic											
2	Colton Basin Area Production	122	0	1	0	0	0	0				Table 2, sheet 3, Line 9
3	Delivery to Edison Highgrove Stream Plant	-	-	-	-	-	-	-	-	-	-	Table 10, Column (17)
4	Colton Production Exported to Riverside Co.	122	0	1	0	0	0	0				Ln 2 - Ln 3
5												
6	Meeks & Daley Water Company											
7	Colton Basin Area Production	222	682	883	298	0	101	0				Table 32, Column (17)
8	Delivery in the Vicinity of Colton	0	0	-	-	-	-	-	-	-	-	Table 33, Column (8)
9	Colton Production Exported to Riverside Co.	222	682	883	298	0	101	0				Table 33, Column (10)
10												
11	Riverside Highland Water Company											
12	Colton Basin Area Production	-	-	-	-	-	-	-	-	-	-	Table 20, Column (4)
13	Delivery North of the County Line	-	-	-	-	-	-	-	-	-	-	After 1989 T 23R, pg 2, Col(8)
14	Colton Production Exported to Riverside Co.	0	0	0	0	0	0	0				After 1989 T 23R, pg 2, Col(9)
15												
16	Reche Canyon Mutual Water Company											See Vol. 2, Reche Cyn M.W.C.
17	Colton Basin Area Production	68	60	55	80	77	72	74				Vol. 2, Table 3
18	Delivery North of the County Line	-	-	-	-	-	-	-	-	-	-	Production & use only in Riv Co.
19	Colton Production Exported to Riverside Co.	68	60	55	80	77	72	74				Production & use only in Riv Co.

Summary of Colton Basin Water Used in San Bernardino County

20	City of Riverside	Line 3	-	-	-	-	-	-	-	-	-	-
21	Meek & Daley	Line 8	0	0	-	-	-	-	-	-	-	-
22	Riverside Highlands	Line 13	0	0	0	0	0	0				
23	Reche Canyon Mutual Water Company	Line 18	-	-	-	-	-	-	-	-	-	-
24	Total		0	0	0	0	0	0				

Summary of Colton Basin Water Exported to Riverside County

25	City of Riverside	Line 4	122	0	1	0	0	0				
26	Meek & Daley	Line 9	222	682	883	298	0	101	0			
27	Riverside Highlands	Line 14	0	0	0	0	0	0				
28	Reche Canyon Mutual Water Company	Line 19	68	60	55	80	77	72	74			
29	Total		412	742	939	378	77	173	74			
30	Total Prod. by Riverside Entities, Lns 24 + 29		412	742	939	378	77	173	74			

TABLE NO. 38

Page 1 of 2

SAN BERNARDINO ENTITIES PRODUCTION FROM COLTON BASIN AREA
FOR USE WITHIN SAN BERNARDINO COUNTY
(Quantities in Acre Feet)

Year	RIVERSIDE ENTITIES				Total Production by San Bernardino Entities used in San Bernardino Co.
	Total Verified Extraction From Colton Basin Area	Production Used in San Bernardino County	Production Used in Riverside County	Total Production	
	(1)	(2)	(3)	(4)	(5)
Base Period Average	11,731	115	3,381	3,496	8,235
1971	11,388	248	2,777	3,025	8,363
1972	10,414	271	2,611	2,882	7,532
1973	7,844	247	615	862	6,982
1974	8,906	273	1,464	1,737	7,169
1975	11,083	389	3,873	4,262	6,821
1976	11,558	265	2,688	2,953	8,605
1977	8,777	447	2,269	2,716	6,061
1978	7,663	338	895	1,233	6,430
1979	7,194	288	1,682	1,970	5,224
1980	5,681	0	76	76	5,605
1981	6,348	0	173	173	6,175
1982	6,499	68	981	1,049	5,450
1983	4,735	37	95	132	4,603
1984	8,987	205	1,341	1,546	7,441
1985	10,149	764	2,243	3,007	7,142
1986	10,035	806	1,578	2,384	7,651
1987	13,175	565	1,556	2,121	11,054
1988	13,552	392	1,707	2,099	11,453
1989	14,103	299	2,005	2,304	11,799
1990	17,571	368	1,652	2,020	15,551
1991	14,323	206	1,835	2,041	12,282
1992	16,750	227	1,455	1,682	15,068
1993	14,977	0	396	396	14,581
1994	15,813	95	1,066	1,161	14,652
1995	17,308	126	489	615	16,693
1996	17,040	78	577	655	16,385
1997	14,498	* 81	1,141	1,222	13,276
1998	10,972	32	251	283	10,689
1999	12,564	222	912	1,134	11,430
2000	13,123	73	213	286	12,837
2001	16,389	168	165	333	16,056
2002	19,161	116	1,279	1,395	17,766
2003	25,656	18	1,062	1,080	24,576
2004	24,346	7	172	179	24,167
2005	18,814	3	84	87	18,727

Column (1) = Total Extractions as verified in Volume 2 for the appropriate year entitled Verified Extractions From Colton Basin Area.

Column (2) = From Table No. 37, Line 24.

Column (3) = From Table No. 37, Line 29.

Column (4) = Column (2) + Column (3).

Column (5) = Column (1) - Column (4).

FOR YEARS PRECEDING 1971: Refer to Volume 5, August 1976, Page II-7.

* Corrected during 1998 verification

TABLE NO. 38

SAN BERNARDINO ENTITIES PRODUCTION FROM COLTON BASIN AREA
FOR USE WITHIN SAN BERNARDINO COUNTY
 (Quantities in Acre Feet)

Year	Total Verified Extraction From Colton Basin Area	RIVERSIDE ENTITIES			Total Production by San Bernardino Entities used in San Bernardino Co.
		Production Used in San Bernardino County	Production Used in Riverside County	Total Production	
	(1)	(2)	(3)	(4)	(5)
Base Period Average	11,731	115	3,381	3,496	8,235
2006	17,566	0	412	412	17,154
2007	20,988	0	742	742	20,246
2008	20,658	0	939	939	19,719
2009	23,536	0	378	378	23,158
2010	24,455	0	77	77	24,378
2011	20,573	0	173	173	20,400
2012	20,149	0	74	74	20,075
2013					
2014					
2015					
2016					
2017					
2018					
2019					
2020					
2021					
2022					
2023					
2024					
2025					
2026					
2027					
2028					
2029					
2030					
2031					
2032					
2033					
2034					
2035					
2036					
2037					
2038					
2039					
2040					

Column (1) = Total Extractions as verified in Volume 2 for the appropriate year entitled Verified Extractions From Colton Basin Area.

Column (2) = From Table No. 37, Line 24.

Column (3) = From Table No. 37, Line 29.

Column (4) = Column (2) + Column (3).

Column (5) = Column (1) - Column (4).

FOR YEARS PRECEDING 1971: Refer to Volume 5, August 1976, Page II-7.

Base Period Average from Volume 5, Table 37, Line 21 and 29, also Volume 2, Table 4

TABLE NO. 38-A

page 1 of 2

COLTON BASIN EXTRACTIONS
BY RIVERSIDE ENTITIES
AND PLACE OF USE
(Quantities in Acre Feet)

Year	Total Extractions	Place of Use	
		San Bernardino County	Riverside County
	(1)	(2)	(3)
Base Period Average	3,496	115	3,381
1971	3,025	248	2,777
1972	2,882	271	2,611
1973	862	247	615
1974	1,737	273	1,464
1975	4,262	389	3,873
1976	2,953	265	2,688
1977	2,716	447	2,269
1978	1,233	338	895
1979	1,970	288	1,682
1980	76	0	76
1981	173	0	173
1982	1,049	68	981
1983	132	37	95
1984	1,546	205	1,341
1985	3,007	764	2,243
1986	2,384	806	1,578
1987	2,121	565	1,556
1988	2,099	392	1,707
1989	2,304	299	2,005
1990	2,020	368	1,652
1991	2,041	206	1,835
1992	1,682	227	1,455
1993	396	0	396
1994	1,161	95	1,066
1995	615	126	489
1996	655	78	577
1997	1,222	81	1,141
1998	283	32	251
1999	1,134	222	912
2000	286	73	213
2001	333	168	165
2002	1,395	116	1,279
2003	1,080	18	1,062
2004	179	7	172
2005	87	3	84

(1) From Table No. 38, Column (4).

(2) From Table No. 38, Column (2).

(3) From Table No. 38, Column (3); Column (1) - Column (2) = Column (3).

Base Period Average from Volume 5, "Verification of Table D-2" page 482

FOR YEARS PRECEDING 1971: Refer to Volume 5, August 1976, Page II-9.

COLTON BASIN EXTRACTIONS
BY RIVERSIDE ENTITIES
AND PLACE OF USE
(Quantities in Acre Feet)

Year	Total Extractions	San Bernardino County	Riverside County
	(1)	(2)	(3)
Base Period Average	3,496	115	3,381
2006	412	0	412
2007	742	0	742
2008	939	0	939
2009	378	0	378
2010	77	0	77
2011	173	0	173
2012	74	0	74
2013			
2014			
2015			
2016			
2017			
2018			
2019			
2020			
2021			
2022			
2023			
2024			
2025			
2026			
2027			
2028			
2029			
2030			
2031			
2032			
2033			
2034			
2035			
2036			
2037			
2038			
2039			
2040			

(1) From Table No. 38, Column (4).
(2) From Table No. 38, Column (2).
(3) From Table No. 38, Column (3); Column (1) - Column (2) = Column (3).
Base Period Average from Volume 5, "Verification of Table D-2" page 482
FOR YEARS PRECEDING 1971: Refer to Volume 5, August 1976, Page II-9.

TABLE NO 39

page 1 of 10

VERIFIED EXTRACTIONS FROM COLTON BASIN AREA
FOR AVERAGE OF FIVE-YEAR PERIOD ENDING WITH
1963 AND FOR CALENDAR YEAR 1970
BY SAN BERNARDINO AND RIVERSIDE COUNTY ENTITIES
FOR USE WITHIN EACH COUNTY

(Quantities in Acre Feet)

Ln. #	Calendar Year	Producer	FIVE - YEAR BASE PERIOD		Total Production in A.F.
			Place of Use		
			San Bernardino County	Riverside County	
1	1959-63	San Bernardino	8,033	0	8,033
	Base	Co. Wtr. Interests			
2	Period	Riverside Co.	115	3,381	3,496
	Averages	Wtr. Interests			
3		TOTAL	8,148	3,381	11,529

See Volume 2, Table 5.

Line 1: Table 38, Column (5).

Line 2: Table 38A, Column (2), (3), (1).

TABLE NO 39

page 2 of 10

VERIFIED EXTRACTIONS FROM COLTON BASIN AREA
BY SAN BERNARDINO AND RIVERSIDE COUNTY ENTITIES
FOR USE WITHIN EACH COUNTY

(Quantities in Acre Feet)

Ln. Calendar #	Year	Producer	Place of Use		Total Production in A.F.
			San Bernardino County	Riverside County	
1	1971	San Bernardino Co. Wtr. Interests	8,363	0	8,363
2		Riverside Co. Wtr. Interests	248	2,777	3,025
3		TOTAL	8,611	2,777	11,388
1	1972	San Bernardino Co. Wtr. Interests	7,532	0	7,532
2		Riverside Co. Wtr. Interests	271	2,611	2,882
3		TOTAL	7,803	2,611	10,414
1	1973	San Bernardino Co. Wtr. Interests	6,982	0	6,982
2		Riverside Co. Wtr. Interests	247	615	862
3		TOTAL	7,229	615	7,844
1	1974	San Bernardino Co. Wtr. Interests	7,169	0	7,169
2		Riverside Co. Wtr. Interests	273	1,464	1,737
3		TOTAL	7,442	1,464	8,906
1	1975	San Bernardino Co. Wtr. Interests	6,821	0	6,821
2		Riverside Co. Wtr. Interests	389	3,873	4,262
3		TOTAL	7,210	3,873	11,083

See Volume 2, Table 5.

Line 1: Table 38, Column (5).

Line 2: Table 38A, Column (2), (3), (1).

Bold values corrected during 1992 verification.

TABLE NO 39

page 3 of 10

VERIFIED EXTRACTIONS FROM COLTON BASIN AREA
BY SAN BERNARDINO AND RIVERSIDE COUNTY ENTITIES
FOR USE WITHIN EACH COUNTY

(Quantities in Acre Feet)

Ln. #	Calendar Year	Producer	Place of Use		Total Production in A.F.
			San Bernardino County	Riverside County	
1	1976	San Bernardino Co. Wtr. Interests	8,605	0	8,605
2		Riverside Co. Wtr. Interests	265	2,688	2,953
3		TOTAL	8,870	2,688	11,558
1	1977	San Bernardino Co. Wtr. Interests	6,061	0	6,061
2		Riverside Co. Wtr. Interests	447	2,269	2,716
3		TOTAL	6,508	2,269	8,777
1	1978	San Bernardino Co. Wtr. Interests	6,430	0	6,430
2		Riverside Co. Wtr. Interests	338	895	1,233
3		TOTAL	6,768	895	7,663
1	1979	San Bernardino Co. Wtr. Interests	5,224	0	5,224
2		Riverside Co. Wtr. Interests	288	1,682	1,970
3		TOTAL	5,512	1,682	7,194
1	1980	San Bernardino Co. Wtr. Interests	5,605	0	5,605
2		Riverside Co. Wtr. Interests	0	76	76
3		TOTAL	5,605	76	5,681

See Volume 2, Table 5.

Line 1: Table 38, Column (5).

Line 2: Table 38A, Column (2), (3), (1).

Bold values corrected during 1992 verification.

TABLE NO 39

page 4 of 10

VERIFIED EXTRACTIONS FROM COLTON BASIN AREA
BY SAN BERNARDINO AND RIVERSIDE COUNTY ENTITIES
FOR USE WITHIN EACH COUNTY

(Quantities in Acre Feet)

Ln. #	Calendar Year	Producer	Place of Use		Total Production in A.F.
			San Bernardino County	Riverside County	
1	1981	San Bernardino Co. Wtr. Interests	6,175	0	6,175
2		Riverside Co. Wtr. Interests	0	173	173
3		TOTAL	6,175	173	6,348
1	1982	San Bernardino Co. Wtr. Interests	5,450	0	5,450
2		Riverside Co. Wtr. Interests	68	981	1,049
3		TOTAL	5,518	981	6,499
1	1983	San Bernardino Co. Wtr. Interests	4,603	0	4,603 *
2		Riverside Co. Wtr. Interests	37	95	132
3		TOTAL	4,640	95	4,735
1	1984	San Bernardino Co. Wtr. Interests	7,441	0	7,441
2		Riverside Co. Wtr. Interests	205	1,341	1,546
3		TOTAL	7,646	1,341	8,987
1	1985	San Bernardino Co. Wtr. Interests	7,142	0	7,142
2		Riverside Co. Wtr. Interests	764	2,243	3,007
3		TOTAL	7,906	2,243	10,149

See Volume 2, Table 5.

Line 1: Table 38, Column (5).

Line 2: Table 38A, Column (2), (3), (1).

* Corrected from previous year

Bold values corrected during 1992 verification.

TABLE NO 39

page 5 of 10

VERIFIED EXTRACTIONS FROM COLTON BASIN AREA
BY SAN BERNARDINO AND RIVERSIDE COUNTY ENTITIES
FOR USE WITHIN EACH COUNTY

(Quantities in Acre Feet)

Ln. #	Calendar Year	Producer	Place of Use		Total Production in A.F.
			San Bernardino County	Riverside County	
1	1986	San Bernardino Co. Wtr. Interests	7,651	0	7,651
2		Riverside Co. Wtr. Interests	806	1,578	2,384
3		TOTAL	8,457	1,578	10,035
1	1987	San Bernardino Co. Wtr. Interests	11,054	0	11,054
2		Riverside Co. Wtr. Interests	565	1,556	2,121
3		TOTAL	11,619	1,556	13,175
1	1988	San Bernardino Co. Wtr. Interests	11,453	0	11,453
2		Riverside Co. Wtr. Interests	392	1,707	2,099
3		TOTAL	11,845	1,707	13,552
1	1989	San Bernardino Co. Wtr. Interests	11,799	0	11,799
2		Riverside Co. Wtr. Interests	299	2,005	2,304
3		TOTAL	12,098	2,005	14,103
1	1990	San Bernardino Co. Wtr. Interests	15,551	0	15,551
2		Riverside Co. Wtr. Interests	368	1,652	2,020
3		TOTAL	15,919	1,652	17,571

See Volume 2, Table 5.

Line 1: Table 38, Column (5).

Line 2: Table 38A, Column (2), (3), (1).

Bold values corrected during 1992 verification.

TABLE NO. 39

page 6 of 10

VERIFIED EXTRACTIONS FROM COLTON BASIN AREA
BY SAN BERNARDINO AND RIVERSIDE COUNTY ENTITIES
FOR USE WITHIN EACH COUNTY

(Quantities in Acre Feet)

Ln. #	Calendar Year	Producer	Place of Use		Total Production in A.F.
			San Bernardino County	Riverside County	
1	1991	San Bernardino Co. Wtr. Interests	12,282	0	12,282
2		Riverside Co. Wtr. Interests	206	1,835	2,041
3		TOTAL	12,488	1,835	14,323
1	1992	San Bernardino Co. Wtr. Interests	15,068	0	15,068
2		Riverside Co. Wtr. Interests	227	1,455	1,682
3		TOTAL	15,295	1,455	16,750
1	1993	San Bernardino Co. Wtr. Interests	14,581	0	14,581
2		Riverside Co. Wtr. Interests	0	396	396
3		TOTAL	14,581	396	14,977
1	1994	San Bernardino Co. Wtr. Interests	14,652	0	14,652
2		Riverside Co. Wtr. Interests	95	1,066	1,161
3		TOTAL	14,747	1,066	15,813 1)
1	1995	San Bernardino Co. Wtr. Interests	16,693	0	16,693
2		Riverside Co. Wtr. Interests	126	489	615 1)
3		TOTAL	16,819	489	17,308 1)

See Table 5, Vol. 2

line 1: Table 38, Column (5)

line 2: Table 38A, Column (2),(3),(1)

Bold value are corrected values during 1996 verification

1) Corrected during 2003 Verification

TABLE NO. 39

page 7 of 10

VERIFIED EXTRACTIONS FROM COLTON BASIN AREA
BY SAN BERNARDINO AND RIVERSIDE COUNTY ENTITIES
FOR USE WITHIN EACH COUNTY

(Quantities in Acre Feet)

Ln. #	Calendar Year	Producer	Place of Use		Total Production in A.F.
			San Bernardino County	Riverside County	
1	1996	San Bernardino Co. Wtr. Interests	16,385	0	16,385
2		Riverside Co. Wtr. Interests	78	577	655
3		TOTAL	16,463	577	17,040 1)
1	1997	San Bernardino Co. Wtr. Interests	13,276	0	13,276
2		Riverside Co. Wtr. Interests	81	1,141	1,222
3		TOTAL	13,357	1,141	14,498 1)
1	1998	San Bernardino Co. Wtr. Interests	10,689	0	10,689
2		Riverside Co. Wtr. Interests	32	251	283
3		TOTAL	10,721	251	10,972 1)
1	1999	San Bernardino Co. Wtr. Interests	11,430	0	11,430
2		Riverside Co. Wtr. Interests	222	912	1,134
3		TOTAL	11,652	912	12,564 1)
1	2000	San Bernardino Co. Wtr. Interests	12,837	0	12,837
2		Riverside Co. Wtr. Interests	73	213 1)	286
3		TOTAL	12,910	213	13,123 1)

See Table 5, Vol. 2

line 1: Table 38, Column (5)

line 2: Table 38A, Column (2),(3),(1)

1) Corrected during 2003 Verification

TABLE NO. 39

page 8 of 10

VERIFIED EXTRACTIONS FROM COLTON BASIN AREA
BY SAN BERNARDINO AND RIVERSIDE COUNTY ENTITIES
FOR USE WITHIN EACH COUNTY

(Quantities in Acre Feet)

Ln. #	Calendar Year	Producer	Place of Use		Total Production in A.F.
			San Bernardino County	Riverside County	
1	2001	San Bernardino Co. Wtr. Interests	16,056 *	0	16,056 1)
2		Riverside Co. Wtr. Interests	168	165	333
3		TOTAL	16,224	165	16,389
1	2002	San Bernardino Co. Wtr. Interests	17,766	0	17,766 1)
2		Riverside Co. Wtr. Interests	116	1279	1,395
3		TOTAL	17,882	1279	19,161
1	2003	San Bernardino Co. Wtr. Interests	24,576	0	24,576 1)
2		Riverside Co. Wtr. Interests	18	1062	1,080
3		TOTAL	24,594	1062	25,656
1	2004	San Bernardino Co. Wtr. Interests	24,167	0	24,167
2		Riverside Co. Wtr. Interests	7	172	179
3		TOTAL	24,174	172	24,346
1	2005	San Bernardino Co. Wtr. Interests	18,727	0	18,727
2		Riverside Co. Wtr. Interests	3	84	87
3		TOTAL	18,730	84	18,814

See Table 5, Vol. 2

line 1: Table 38, Column (5)

line 2: Table 38A, Column (2),(3),(1)

* Corrected during 2002 verification, backfile on new San Gabriel well 3603739

1) Corrected during 2003 Verification

TABLE NO. 39

VERIFIED EXTRACTIONS FROM COLTON BASIN AREA
BY SAN BERNARDINO AND RIVERSIDE COUNTY ENTITIES
FOR USE WITHIN EACH COUNTY

(Quantities in Acre Feet)

Ln. #	Calendar Year	Producer	Place of Use		Total Production in A.F.
			San Bernardino County	Riverside County	
1	2006	San Bernardino Co. Wtr. Interests	17,154	0	17,154
2		Riverside Co. Wtr. Interests	0	412	412
3		TOTAL	17,154	412	17,566
1	2007	San Bernardino Co. Wtr. Interests	20,246	0	20,246
2		Riverside Co. Wtr. Interests	0	742	742
3		TOTAL	20,246	742	20,988
1	2008	San Bernardino Co. Wtr. Interests	19,719	0	19,719
2		Riverside Co. Wtr. Interests	0	939	939
3		TOTAL	19,719	939	20,658
1	2009	San Bernardino Co. Wtr. Interests	23,158	0	23,158
2		Riverside Co. Wtr. Interests	0	378	378
3		TOTAL	23,158	378	23,536
1	2010	San Bernardino Co. Wtr. Interests	24,378	0	24,378
2		Riverside Co. Wtr. Interests	0	77	77
3		TOTAL	24,378	77	24,455

See Table 5, Vol. 2

line 1: Table 38, Column (5)

line 2: Table 38A, Column (2),(3),(1)

corrected during 2011 verification, lost M&D #36 production

TABLE NO. 39

VERIFIED EXTRACTIONS FROM COLTON BASIN AREA
BY SAN BERNARDINO AND RIVERSIDE COUNTY ENTITIES
FOR USE WITHIN EACH COUNTY

(Quantities in Acre Feet)

Ln. #	Calendar Year	Producer	Place of Use		Total Production in A.F.
			San Bernardino County	Riverside County	
1	2011	San Bernardino Co. Wtr. Interests	20,400	0	20,400
2		Riverside Co. Wtr. Interests	0	173	173
3		TOTAL	20,400	173	20,573
1	2012	San Bernardino Co. Wtr. Interests	20,075	0	20,075
2		Riverside Co. Wtr. Interests	0	74	74
3		TOTAL	20,075	74	20,149
1	2013	San Bernardino Co. Wtr. Interests			
2		Riverside Co. Wtr. Interests			
3		TOTAL			
1	2014	San Bernardino Co. Wtr. Interests			
2		Riverside Co. Wtr. Interests			
3		TOTAL			
1	2015	San Bernardino Co. Wtr. Interests			
2		Riverside Co. Wtr. Interests			
3		TOTAL			

See Table 5, Vol. 2

line 1: Table 38, Column (5)

line 2: Table 38A, Column (2),(3),(1)

TABLE NO. 39-A

GROUNDWATER EXTRACTIONS BY RIVERSIDE ENTITIES FROM
COLTON BASIN AREA FOR USE IN RIVERSIDE AND SAN BERNARDINO COUNTIES
FOR THE 1959-63 BASE PERIOD

CLASSIFIED ACCORDING TO SERVICE AREA
(all values in Acre Feet)

EXTRACTIONS FROM COLTON BASIN AREA FOR USE WITHIN AND EXPORT THEREFROM

PLAINTIFFS	1959			1960			1960			1962			1963			1959-63 5 Yr average		
	Total	Del. in	Del. in	Total	Del. in	Del. in	Total	Del. in	Del. in	Total	Del. in	Del. in	Total	Del. in	Del. in	Total	Del. in	Del. in
	Extract	S.B. Co.	Riv. Co.	Extract	S.B. Co.	Riv. Co.	Extract	S.B. Co.	Riv. Co.	Extract	S.B. Co.	Riv. Co.	Extract	S.B. Co.	Riv. Co.	Extract	S.B. Co.	Riv. Co.
CITY OF RIVERSIDE Dom & Irrig.	2,871	41	2,830	2,165	28	2,137	3,486	0	3,486	1,835	0	1,835	1,807	7	1,800	2,433	15	2,418
MEEKS & DALEY WATER CO.	2,168	88	2,080	23	1	22	465	18	447	1,185	57	1,128	339	13	326	836	35	801
RIVERSIDE HIGHLAND WATER CO.	211	50	161	126	27	99	357	107	250	280	96	184	163	47	116	227	97	162
RECHE CANYON MUTUAL WATER CO.																		
TOTALS	5,250	179	5,071	2,314	56	2,258	4,308	125	4,183	3,300	153	3,147	2,309	67	2,242	3,496	147	3,381

Total Extract -- TOTAL EXTRACTIONS.
See Table No. 37.

Reche Canyon Mutual Water Company was not identified until after the Base Period work was completed

TABLE NO. 39-A

GROUNDWATER EXTRACTIONS BY RIVERSIDE ENTITIES FROM
COLTON BASIN AREA FOR USE IN RIVERSIDE AND SAN BERNARDINO COUNTIES
FROM 1976 THROUGH CURRENT YEAR

CLASSIFIED ACCORDING TO SERVICE AREA
(all values in Acre Feet)

EXTRACTIONS FROM COLTON BASIN AREA FOR USE WITHIN AND EXPORT THEREFROM

PLAINTIFFS	1971			1972			1973			1974			1975		
	Total Extract	Del. in S.B. Co.	Del. in Riv. Co.	Total Extract	Del. in S.B. Co.	Del. in Riv. Co.	Total Extract	Del. in S.B. Co.	Del. in Riv. Co.	Total Extract	Del. in S.B. Co.	Del. in Riv. Co.	Total Extract	Del. in S.B. Co.	Del. in Riv. Co.
CITY OF RIVERSIDE Dom & Irrig.	2,696	0	2,696	2,521	0	2,521	101	0	101	1,386	0	1,386	2,545	0	2,545
MEEKS & DALEY WATER CO.	0	0	0	0	0	0	484	41	443	0	0	0	1,350	98	1,252
RIVERSIDE HIGHLAND WATER CO.	256	248	8	285	271	14	212	206	6	282	273	9	300	291	9
RECHE CANYON MUTUAL WATER CO.	73	-	73	76	-	76	65	-	65	69	-	69	67	-	67
TOTALS	3,025	248	2,777	2,882	271	2,611	862	247	615	1,737	273	1,464	4,262	389	3,873

Total Extract -- TOTAL EXTRACTIONS.

Del in S.B. Co. -- DELIVERY WITHIN SAN BERNARDINO COUNTY.

Del. in Riv. Co. -- DELIVERY WITHIN RIVERSIDE COUNTY.

See Table 37

For Years Preceding 1971: Refer to Volume 5, August 1976, Page 11-13

Same as Volume 2 Table 4

TABLE NO. 39-A

GROUNDWATER EXTRACTIONS BY RIVERSIDE ENTITIES FROM
COLTON BASIN AREA FOR USE IN RIVERSIDE AND SAN BERNARDINO COUNTIES
FROM 1976 THROUGH CURRENT YEAR

CLASSIFIED ACCORDING TO SERVICE AREA
(all values in Acre Feet)

PLAINTIFFS	1976			1977			1978			1979			1980		
	Total Extract	Del. in S.B. Co.	Del. in Riv. Co.	Total Extract	Del. in S.B. Co.	Del. in Riv. Co.	Total Extract	Del. in S.B. Co.	Del. in Riv. Co.	Total Extract	Del. in S.B. Co.	Del. in Riv. Co.	Total Extract	Del. in S.B. Co.	Del. in Riv. Co.
CITY OF RIVERSIDE Dom & Irrig.	853	0	853	295	0	295	464	0	464	5	0	5	5	0	5
MEEKS & DALEY WATER CO.	1,860	100	1,760	2,018	125	1,893	422	78	344	1,698	104	1,594	0	0	0
RIVERSIDE HIGHLAND WATER CO.	170	165	5	332	322	10	270	260	10	191	184	7	0	0	0
RECHE CANYON MUTUAL WATER CO.	70	-	70	71	-	71	77	-	77	76	-	76	71	-	71
TOTALS	2,953	265	2,688	2,716	447	2,269	1,233	338	895	1,970	288	1,682	76	0	76

Total Extract -- TOTAL EXTRACTIONS.

Del in S.B. Co. -- DELIVERY WITHIN SAN BERNARDINO COUNTY.

Del. in Riv. Co. -- DELIVERY WITHIN RIVERSIDE COUNTY.

See Table 37

For Years Preceding 1971: Refer to Volume 5, August 1976, Page 11-13

Same as Volume 2 Table 4

TABLE NO. 39-A

GROUNDWATER EXTRACTIONS BY RIVERSIDE ENTITIES FROM
COLTON BASIN AREA FOR USE IN RIVERSIDE AND SAN BERNARDINO COUNTIES
FROM 1976 THROUGH CURRENT YEAR

CLASSIFIED ACCORDING TO SERVICE AREA
(all values in Acre Feet)

PLAINTIFFS	1981			1982			1983			1984			1985		
	Total Extract	Del. in S.B. Co.	Del. in Riv. Co.	Total Extract	Del. in S.B. Co.	Del. in Riv. Co.	Total Extract	Del. in S.B. Co.	Del. in Riv. Co.	Total Extract	Del. in S.B. Co.	Del. in Riv. Co.	Total Extract	Del. in S.B. Co.	Del. in Riv. Co.
CITY OF RIVERSIDE Dom & Irrig.	77	0	77	57	-	57	0	-	0	0	-	0	695	-	695
MEEKS & DALEY WATER CO.	0	0	0	910	68	842	50	37	13	1,383	125	1,258	1,554	113	1,441
RIVERSIDE HIGHLAND WATER CO.	0	0	0	0	0	0	0	0	0	83	80	3	675	651	24
RECHE CANYON MUTUAL WATER CO.	96	-	96	0	-	82	82	-	82	80	-	80	83	-	83
TOTALS	173	0	173	967	68	981	132	37	95	1,546	205	1,341	3,007	764	2,243

Total Extract -- TOTAL EXTRACTIONS.

Del in S.B. Co. -- DELIVERY WITHIN SAN BERNARDINO COUNTY.

Del. in Riv. Co. -- DELIVERY WITHIN RIVERSIDE COUNTY.

See Table 37

For Years Preceding 1971: Refer to Volume 5, August 1976, Page 11-13

Same as Volume 2 Table 4

TABLE NO. 39-A

GROUNDWATER EXTRACTIONS BY RIVERSIDE ENTITIES FROM
COLTON BASIN AREA FOR USE IN RIVERSIDE AND SAN BERNARDINO COUNTIES
FROM 1976 THROUGH CURRENT YEAR

CLASSIFIED ACCORDING TO SERVICE AREA
(all values in Acre Feet)

PLAINTIFFS	1986			1987			1988			1989			1990		
	Total Extract	Del. in S.B. Co.	Del. in Riv. Co.	Total Extract	Del. in S.B. Co.	Del. in Riv. Co.	Total Extract	Del. in S.B. Co.	Del. in Riv. Co.	Total Extract	Del. in S.B. Co.	Del. in Riv. Co.	Total Extract	Del. in S.B. Co.	Del. in Riv. Co.
CITY OF RIVERSIDE Dom & Irrig.	0	-	0	0	-	0	0	-	0	519	-	519	131	-	131
MEEKS & DALEY WATER CO.	1,575	115	1,460	1,560	114	1,446	1,754	150	1,604	1,538	157	1,381	1,691	306	1,385
RIVERSIDE HIGHLAND WATER CO.	721	691	30	471	451	20	256	242	14	158	142	16	109	62	47
RECHE CANYON MUTUAL WATER CO.	88	-	88	90	-	90	89	-	89	89	-	89	89	-	89
TOTALS	2,384	806	1,578	2,121	565	1,556	2,099	392	1,707	2,304	299	2,005	2,020	368	1,652

Total Extract -- TOTAL EXTRACTIONS.

Del in S.B. Co. -- DELIVERY WITHIN SAN BERNARDINO COUNTY.

Del. in Riv. Co. -- DELIVERY WITHIN RIVERSIDE COUNTY.

See Table 37

For Years Preceding 1971: Refer to Volume 5, August 1976, Page 11-13

Same as Volume 2 Table 4

TABLE NO. 39-A

GROUNDWATER EXTRACTIONS BY RIVERSIDE ENTITIES FROM
COLTON BASIN AREA FOR USE IN RIVERSIDE AND SAN BERNARDINO COUNTIES
FROM 1976 THROUGH CURRENT YEAR

CLASSIFIED ACCORDING TO SERVICE AREA
(all values in Acre Feet)

EXTRACTIONS FROM COLTON BASIN AREA FOR USE WITHIN AND EXPORT THEREFROM

PLAINTIFFS	1991			1992			1993			1994			1995		
	Total Extract	Del. in S.B. Co.	Del. in Riv. Co.	Total Extract	Del. in S.B. Co.	Del. in Riv. Co.	Total Extract	Del. in S.B. Co.	Del. in Riv. Co.	Total Extract	Del. in S.B. Co.	Del. in Riv. Co.	Total Extract	Del. in S.B. Co.	Del. in Riv. Co.
CITY OF RIVERSIDE Dom & Irrig.	428	-	428	307	-	307	311	-	311	466	-	466	171	-	171
MEEKS & DALEY WATER CO.	1,530	204	1,326	1,209	176	1,033	0	0	0	586	95	491	344	126	218
RIVERSIDE HIGHLAND WATER CO.	4	2	2	91	51	40	0	0	0	0	0	0	0	0	0
RECHE CANYON MUTUAL WATER CO.	79	-	79	75	-	75	85	-	85	109	-	109	100	-	100
TOTALS	2,041	206	1,835	1,682	227	1,455	396	0	396	1,161	95	1,066	615	126	489

Total Extract -- TOTAL EXTRACTIONS
Del in S.B. Co. -- DELIVERY WITHIN SAN BERNARDINO COUNTY
Del. in Riv. Co. -- DELIVERY WITHIN RIVERSIDE COUNTY

See Table 37 for figures
FOR YEARS PRECEDING 1976: Refer to Volume 5-1974, August 1976, Page II-13
Same as Table 4, Volume 2

TABLE NO. 39-A

GROUNDWATER EXTRACTIONS BY RIVERSIDE ENTITIES FROM
 COLTON BASIN AREA FOR USE IN RIVERSIDE AND SAN BERNARDINO COUNTIES
 FROM 1976 THROUGH CURRENT YEAR

CLASSIFIED ACCORDING TO SERVICE AREA
 (all values in Acre Feet)

EXTRACTIONS FROM COLTON BASIN AREA FOR USE WITHIN AND EXPORT THEREFROM

PLAINTIFFS	1996			1997			1998			1999			2000		
	Total Extract	Del. in S.B. Co.	Del. in Riv. Co.	Total Extract	Del. in S.B. Co.	Del. in Riv. Co.	Total Extract	Del. in S.B. Co.	Del. in Riv. Co.	Total Extract	Del. in S.B. Co.	Del. in Riv. Co.	Total Extract	Del. in S.B. Co.	Del. in Riv. Co.
CITY OF RIVERSIDE Dom & Irrig.	208	0	208	633	0	633	142	0	142	7	0	7	128	0	128
MEEKS & DALEY WATER CO.	362	78	284	484	81	403	88	32	56	1,066	222	844	102	73	29
RIVERSIDE HIGHLAND WATER CO.	0	0	0	0	0	0	0	0	0	0	0	0	0	0	0
RECHE CANYON MUTUAL WATER CO.	85	0	85	105	0	105	53	0	53	61	0	61	56	0	56
TOTALS	655	78	577	1,222	81	1,141	283	32	251	1,134	222	912	286	73	213

Total Extract -- TOTAL EXTRACTIONS

Del in S.B. Co. -- DELIVERY WITHIN SAN BERNARDINO COUNTY

Del. in Riv. Co. -- DELIVERY WITHIN RIVERSIDE COUNTY

See Table 37 for figures

FOR YEARS PRECEDING 1976: Refer to Volume 5-1974, August 1976, Page II-13

Same as Table 4, Volume 2

TABLE NO. 39-A

GROUNDWATER EXTRACTIONS BY RIVERSIDE ENTITIES FROM
 COLTON BASIN AREA FOR USE IN RIVERSIDE AND SAN BERNARDINO COUNTIES
 FROM 1976 THROUGH CURRENT YEAR

CLASSIFIED ACCORDING TO SERVICE AREA
 (all values in Acre Feet)

EXTRACTIONS FROM COLTON BASIN AREA FOR USE WITHIN AND EXPORT THEREFROM

PLAINTIFFS	2001			2002			2003			2004			2005		
	Total	Del. in	Del. in	Total	Del. in	Del. in	Total	Del. in	Del. in	Total	Del. in	Del. in	Total	Del. in	Del. in
	Extract	S.B. Co.	Riv. Co.	Extract	S.B. Co.	Riv. Co.	Extract	S.B. Co.	Riv. Co.	Extract	S.B. Co.	Riv. Co.	Extract	S.B. Co.	Riv. Co.
CITY OF RIVERSIDE Dom & Irrig.	0	0	0	0	0	0	171	0	171	0	0	0	0	0	0
MEEKS & DALEY WATER CO.	285	168	117	1,322	116	1,206	844	18	826	120	7	113	30	3	27
RIVERSIDE HIGHLAND WATER CO.	0	0	0	0	0	0	0	0	0	0	0	0	0	0	0
RECHE CANYON MUTUAL WATER CO.	48	0	48	73	0	73	65	0	65	59	0	59	57	0	57
TOTALS	333	168	165	1,395	116	1,279	1,080	18	1,062	179	7	172	87	3	84

Total Extract -- TOTAL EXTRACTIONS

Del in S.B. Co. -- DELIVERY WITHIN SAN BERNARDINO COUNTY

Del. in Riv. Co. -- DELIVERY WITHIN RIVERSIDE COUNTY

See Table 37 for figures

FOR YEARS PRECEDING 1976: Refer to Volume 5-1974, August 1976, Page II-13

Same as Table 4, Volume 2

TABLE NO. 39-A

GROUNDWATER EXTRACTIONS BY RIVERSIDE ENTITIES FROM
COLTON BASIN AREA FOR USE IN RIVERSIDE AND SAN BERNARDINO COUNTIES
FROM 1976 THROUGH CURRENT YEAR

CLASSIFIED ACCORDING TO SERVICE AREA
(all values in Acre Feet)

EXTRACTIONS FROM COLTON BASIN AREA FOR USE WITHIN AND EXPORT THEREFROM

PLAINTIFFS	2006			2007			2008			2009			2010		
	Total Extract	Del. in S.B. Co.	Del. in Riv. Co.	Total Extract	Del. in S.B. Co.	Del. in Riv. Co.	Total Extract	Del. in S.B. Co.	Del. in Riv. Co.	Total Extract	Del. in S.B. Co.	Del. in Riv. Co.	Total Extract	Del. in S.B. Co.	Del. in Riv. Co.
CITY OF RIVERSIDE Dom & Irrig.	122	-	122	0	-	0	1	-	1	0	-	0	0	-	0
MEEKS & DALEY WATER CO.	222	0	222	682	0	682	883	-	883	298	-	298	0	-	0
RIVERSIDE HIGHLAND WATER CO.	-	-	-	-	-	-	-	-	-	-	-	-	-	-	-
RECHE CANYON MUTUAL WATER CO.	68	-	68	60	-	60	55	-	55	80	-	80	77	-	77
TOTALS	412	0	412	742	0	742	939	0	939	378	0	378	77	0	77

Total Extract -- TOTAL EXTRACTIONS
Del in S.B. Co. -- DELIVERY WITHIN SAN BERNARDINO COUNTY
Del. in Riv. Co. -- DELIVERY WITHIN RIVERSIDE COUNTY

See Table 37 for figures
FOR YEARS PRECEDING 1976: Refer to Volume 5-1974, August 1976, Page II-13
Same as Table 4, Volume 2

TABLE NO. 39-A

GROUNDWATER EXTRACTIONS BY RIVERSIDE ENTITIES FROM
 COLTON BASIN AREA FOR USE IN RIVERSIDE AND SAN BERNARDINO COUNTIES
 FROM 1976 THROUGH CURRENT YEAR

CLASSIFIED ACCORDING TO SERVICE AREA
 (all values in Acre Feet)

EXTRACTIONS FROM COLTON BASIN AREA FOR USE WITHIN AND EXPORT THEREFROM

PLAINTIFFS	2011			2012			2013			2014			2015		
	Total	Del. in	Del. in	Total	Del. in	Del. in	Total	Del. in	Del. in	Total	Del. in	Del. in	Total	Del. in	Del. in
	Extract	S.B. Co.	Riv. Co.	Extract	S.B. Co.	Riv. Co.	Extract	S.B. Co.	Riv. Co.	Extract	S.B. Co.	Riv. Co.	Extract	S.B. Co.	Riv. Co.
CITY OF RIVERSIDE Dom & Irrig.	0	-	0	0	-	0	-	-	-	-	-	-	-	-	-
MEEKS & DALEY WATER CO.	101	-	101	0	-	0	-	-	-	-	-	-	-	-	-
RIVERSIDE HIGHLAND WATER CO.	-	-	-	-	-	-	-	-	-	-	-	-	-	-	-
RECHE CANYON MUTUAL WATER CO.	72	-	72	74	-	74	-	-	-	-	-	-	-	-	-
TOTALS	173	0	173	74	0	74									

Total Extract -- TOTAL EXTRACTIONS

Del in S.B. Co. -- DELIVERY WITHIN SAN BERNARDINO COUNTY

Del. in Riv. Co. -- DELIVERY WITHIN RIVERSIDE COUNTY

See Table 37 for figures

FOR YEARS PRECEDING 1976: Refer to Volume 5-1974, August 1976, Page II-13

Same as Table 4, Volume 2

Volume 5

Tables 40-54

Riverside North Basin
production and deliveries by
both Riverside and San
Bernardino Entities

TABLE NO. 40

RIVERSIDE CEMENT COMPANY*
DIVISION, AMERICAN CEMENT CORP.
WATER PRODUCTION
FROM RIVERSIDE GROUND WATER BASIN
SITUATED WITHIN SAN BERNARDINO COUNTY

(All Quantities in Acre Feet)

Production from Recordation Filings (Volume 3, Table No.1)

State Well No.	1S/5W-34K	1S/5W-34K02S	Production	2S/5W-02A	2S/5W-02G2	2S/5W-02R	2S/5W-02L02S	2S/5W-02G	Production	Total Production
Rec. No.	3601721	3600873	Exported to	3600874	3600883	3601722	3601782	3602114	Used In	in
Well Name	E. Crestmore #56	W. Crestmore #57	Riveside Co.	White Well °	Wright °	New White 58-1	None	63-1	San Bernardino	San Bernardino
Basin	Riverside North	Riverside North		Riverside North	Riverside North	Riverside North	Riverside North	Riverside North	County	County
Year	(1)	(2)	(3)	(4)	(5)	(6)	(7)	(8)	(9)	(10)
1971	130	219	482	0	0	0	-	482	482	964
1972	353	20	373	0	0	0	-	204	204	577
1973	531	6	537	0	0	0	-	0	0	537
1974	133	0 (a)	133	0	0	0	-	0	0	133
1975	0 (b)	0 (a)	0 (a) (b)	0	0	0	-	0	0	0 (a) (b)
1976	0 (b)	0 (a)	0 (a) (b)	0	0	0	-	218	218	218
1977	0 (b)	0 (a)	0 (a) (b)	0	0	0	0	446	446	446
1978	0 (b)	0 (a)	0 (a) (b)	0	0	0	0	227	227	227
1979	0 (b)	0 (a)	0 (a) (b)	0	0	0	0	436	436	436
1980	0 (b)	0 (a)	0 (a) (b)	0	0	0	0	218	218	218
1981	0 (b)	0 (a)	0	0	0	0	0	413	413	413
1982	0 (b)	0 (a)	0	0	0	0	0	0	0	0
1983	-	-	0	0	0	0	0	0	0	0
1984	-	-	0	0	0	0	0	0	0	0
1985	-	-	0	0	0	0	0	0	0	0
1986	-	-	0	0	0	0	0	0	0	0
1987	-	-	0	0	0	0	0	0	0	0
1988	-	-	0	0	0	0 (c)	0	0 (c)	0	0
1989										
1990										

All wells sold or abandoned

(a) 3600873 sold to Green Acres Mem. Ass'n. 1974

(b) 3601721 sold to Green Acres Mem. Park Ass'n. 1975

(c) Sold to Erin Madison in 1988

° Abandoned or File Closed

* Name changed to Amcord, Inc. 1973 & recurred in 1981

(3) Col. (2) + Col. (1)

(9) Cols. (4) + (5) + (6) + (7) + (8)

(10) Col. (3) + Col. (9)

For Years Preceding 1971: Refer to Volume 5, August 1976, Page III-7

TABLE NO. 41

RIVERSIDE CEMENT COMPANY
WATER PRODUCTION FROM RIVERSIDE GROUND WATER BASIN
WITHIN SAN BERNARDINO COUNTY FOR PERIOD 1971 THROUGH CURRENT YEAR
AND PRODUCTION DELIVERED IN RIVERSIDE AND SAN BERNARDINO COUNTIES

(Quantities in Acre Feet)

Year	Production Exported to Riverside County (1)	Production Used in San Bernardino County (2)	Total Production (3)
1971	349	482	831
1972	373	204	577
1973	537	0	537
1974	133	0	133
1975	0	0	0
1976	0	218	218
1977	0	446	446
1978	0	227	227
1979	0	436	436
1980	0	218	218
1981	0	413	413
1982	0	0	0
1983	0	0	0
1984	0	0	0
1985	0	0	0
1986	0	0	0
1987	0	0	0
1988	0	0	0
1989			
1990	All wells sold or abandoned		

Col. (1) from Table No. 40, Col (3)

Col. (2) from Table No. 40, Col (9)

Col. (3) from Table No. 40, Col (10)

FOR YEARS PRECEDING 1971: Refer to Volume 5, August

TABLE NO. 42

Page 1 of 2

CITY OF RIVERSIDE
 IRRIGATION AND DOMESTIC DIVISION
 WATER PRODUCTION FROM RIVERSIDE GROUNDWATER BASIN
 WITHIN SAN BERNARDINO COUNTY FOR THE PERIOD 1971 THROUGH CURRENT YEAR

(Quantities in Acre Feet)

Year	Production Exported to Riverside County	Production Used In San Bernardino County	Total Production
	(1)	(2)	(3)
Base Period Average	9,500	754	10,254
1971	4,363	174	4,537
1972	5,813	107	5,920
1973	4,941	45	4,986
1974	6,012	111	6,123
1975	5,744	94	5,838
1976	6,219	126	6,345
1977	3,833	279	4,112
1978	1,093	271	1,364
1979	2,249	587	2,836
1980	115	1,591	1,706
1981	1,368	1,526	2,894
1982	1,513	2,102	3,615
1983	648	1,933	2,581
1984	2,443	448	2,891
1985	2,479	714	3,193
1986	2,225	117	2,342
1987	1,675	87	1,762
1988	3,257	58	3,315
1989	10,135	59	10,194
1990	9,972	1,011	10,983
1991	12,198	1,005	13,203
1992	10,009	334	10,343
1993	9,231	69	9,300
1994	8,131	72	8,203
1995	10,755	0	10,755

Column (1) = Table No. 12, Page 1, Column (9) thru 1982

Column (1) = Table No. 12, Page 2, Column (9) thru 2006

Column (2) = Table No. 12, Page 1, Column (8) thru 1982

Column (2) = Table No. 12, Page 2, Column (8)

Column (3) = Column (1) + Column (2)

Column (3) = Table No. 2, Sheet 1, Page 1 or 2, Line 43, or Table No. 12, Column (2).

Base Period Average found in Base Period Report for Table 42, page 501

TABLE NO. 42

page 2 of 2

CITY OF RIVERSIDE
IRRIGATION AND DOMESTIC DIVISION
WATER PRODUCTION FROM RIVERSIDE GROUNDWATER BASIN
WITHIN SAN BERNARDINO COUNTY FOR THE PERIOD 1971 THROUGH CURRENT YEAR
AND PRODUCTION DELIVERED IN RIVERSIDE AND SAN BERNARDINO COUNTIES

(Quantities in Acre Feet)

Year	Production Exported to Riverside County (1)	Production Used In San Bernardino County (2)	Total Production (3)
Base Period Average	9,500	754	10,254
1996	9,064	0	9,064
1997	8,169	0	8,169
1998	6,765	0	6,765
1999	8,883	0	8,883
2000	8,629	0	8,629
2001	7,288	0	7,288
2002	7,814	0	7,814
2003	6,390	0	6,390
2004	5,123	0	5,123
2005	7,829	0	7,829
2006	10,276	0	10,276
2007	5,688	0	5,688
2008	8,802	0	8,802
2009	13,614	0	13,614
2010	11,045	0	11,045
2011	12,043	0	12,043
2012	13,876	0	13,876
2013			
2014			
2015			
2016			
2017			
2018			
2019			
2020			
2021			
2022			
2023			
2024			
2025			

Column (1) = Table No. 12, Page 2, Column (9) thru 2005

Column (1) = Table No. 12, Page 3, Column (9)

Column (2) = Table No. 12, Page 2, Column (8) thru 2005

Column (2) = Table No. 12, Page 3, Column (8)

Column (3) = Column (1) + Column (2)

Column (3) = Table No. 2, Sheet 1, Page 3 or 4, Line 43 or Table No. 12,
Base Period Average found in Base Period Report for Table 42, page 501

TABLE NO. 43

CITY OF RIVERSIDE
IRRIGATION & DOMESTIC DIVISION
GAGE CANAL COMPANY
WATER PRODUCTION FROM RIVERSIDE GROUNDWATER BASIN
WITHIN SAN BERNARDINO COUNTY FOR THE PERIOD 1971 THROUGH CURRENT YEAR
AND PRODUCTION DELIVERED IN RIVERSIDE AND SAN BERNARDINO COUNTIES

(Quantities in Acre Feet)

Year	Production Exported to Riverside County (1)	Production Used in San Bernardino County (2)	Total Production (3)
Base Period Average	1,403	0	1,403
1971	567	0	567
1972	778	0	778
1973	222	0	222
1974	374	98	472
1975	568	77	645
1976	378	62	440
1977	383	6	389
1978	730	4	734
1979	409	4	413
1980	2,028	4	2,032
1981	2,464	3	2,467
1982	1,644	1	1,645
1983	1,018	1	1,019
1984	2,044	2	2,046
1985	1,860	1	1,861
1986	1,891	2	1,893
1987	1,995	1	1,996
1988	2,187	2	2,189
1989	1,963	2	1,965
1990	1,961	1	1,962
1991	1,733	1	1,734
1992	1,656	1	1,657
1993	2,021	2	2,023
1994	2,026	2	2,028
1995	1,664	0	1,664
1996	1,706	0	1,706
1997	1,591	0	1,591
1998	1,823	0	1,823
1999	2,051	0	2,051
2000	1,664	0	1,664
2001	1,491	0	1,491
2002	1,286	0	1,286
2003	1,339	0	1,339
2004	1,125	0	1,125
2005	1,354	-	1,354

Column (1) = Table No. 17, Column (15).

Column (2) = Table No. 17, Column (14a).

Column (3) = Table No. 15, Line 24.

Base Period Average from Base Period Table 43, page 502

TABLE NO. 43

CITY OF RIVERSIDE
IRRIGATION & DOMESTIC DIVISION
GAGE CANAL COMPANY
WATER PRODUCTION FROM RIVERSIDE GROUNDWATER BASIN
WITHIN SAN BERNARDINO COUNTY FOR THE PERIOD 1971 THROUGH CURRENT YEAR
AND PRODUCTION DELIVERED IN RIVERSIDE AND SAN BERNARDINO COUNTIES

(Quantities in Acre Feet)

Year	Production Exported to Riverside County (1)	Production Used in San Bernardino County (2)	Total Production (3)
Base Period Average	1,403	0	1,403
2006	1,969	-	1,969
2007	1,870	-	1,870
2008	1,849	-	1,849
2009	1,601	-	1,601
2010	1,074	-	1,074
2011	693	-	693
2012	1,304	-	1,304
2013		-	
2014		-	
2015		-	
2016		-	
2017		-	
2018		-	
2019		-	
2020		-	
2021		-	
2022		-	
2023		-	
2024		-	
2025		-	

Column (1) = Table No. 17, Column (15).

Column (2) = Table No. 17, Column (14a).

Column (3) = Column (1) + Column (2)

Column (3) = Table No. 15, Line 29

Base Period Average from Base Period Table 43, page 502

TABLE NO. 44

page 1 of 2

INTER COUNTY WATER COMPANY
WATER PRODUCTION FROM RIVERSIDE GROUND WATER BASIN
WITHIN SAN BERNARDINO COUNTY FOR PERIOD 1971 THROUGH CURRENT YEAR
AND PRODUCTION DELIVERED IN RIVERSIDE AND SAN BERNARDINO COUNTIES
(Quantities in Acre Feet)

Year	Total Production 02S/05W-02C 3301347 (1)	Production		Delivered by WSBCWD to Riverside Co. (4)
		Exported To Riverside Co. (2)	Used In San Bernardino Co. (3)	
Base Period Average	133	81	52	-
1971	83	51	32	
1972	95	58	37	
*1973	157	96	61	
1974	206	125	81	
1975	225	137	88	
1976	230	78	152	
1977	207	70	137	
1978	145	49	96	
1979	225	76	149	
1980	228	78	150	
1981	175	60	115	
1982	200	68	132	
1983	154	52	102	
1984	207	71	136	
1985	196	67	129	
1986	189	64	125	
**1987	78	27	51	
1988	0	21	0	21
1989	0	21	0	21
1990	0	0	0	21
1991	-	0	0	21
1992	-	0	0	21
1993	-	0	0	21
1994	-	0	0	21
1995	-	0	0	21
1996	-	0	0	21
1997	-	0	0	21
1998	-	0	0	21
1999	-	0	0	21
2000	-	0	0	21
2001	-	0	0	21
2002	-	0	0	21
2003	-	0	0	21
2004	-	0	0	21
2005	-	0	0	21

** Intercounty acquired by West San Bernardino County Water District, in 1988 WSBCWD had 17 accounts in Riverside County. Assume 1.25 A.F. per account.

Note: Col. (1) from Volume 3, Table No. 1.

FOR YEARS PRECEDING 1971: Refer to Volume 5, August 1976, Page III-15.

TABLE NO. 44

WEST VALLEY WATER DISTRICT (WAS INTER COUNTY WATER COMPANY)
WATER PRODUCTION FROM RIVERSIDE GROUND WATER BASIN
WITHIN SAN BERNARDINO COUNTY FOR PERIOD 1971 THROUGH CURRENT YEAR
AND PRODUCTION DELIVERED IN RIVERSIDE AND SAN BERNARDINO COUNTIES
 (Quantities in Acre Feet)

Year	Total	Production		Delivered by WVWD to Riverside Co.
	Production 2S5W02C 3301347	Exported To Riverside Co.	Used In San Bernardino Co.	
	(1)	(2)	(3)	(4)
Base Period Average	133	81	52	-
2006	-	0	0	21
2007	-	0	0	21
2008	-	0	0	277
2009	-	0	0	275
2010	-	0	0	275
2011	-	0	0	275
2012	-	0	0	202
2013				
2014				
2015				
2016				
2017				
2018				
2019				
2020				
2021				
2022				
2023				
2024				
2025				
2026				
2027				
2028				
2029				
2030				
2031				
2032				
2033				
2034				
2035				
2036				
2037				
2038				
2039				
2040				

** Intercounty acquired by West Valley Water District, in 1988
 WSBCWD had 17 accounts in Riverside County. Assume 1.25 A.F. per account.
 2011 added Agua Mansa business park water deliveries in Riverside County.
 Data from West Valley Records

Note: Col. (1) from Volume 3, Table No. 1.
 FOR YEARS PRECEDING 1971: Refer to Volume 5, August 1976, Page III-15.

TABLE NO. 45

JURUPA WATER COMPANY **

WATER PRODUCTION FROM RIVERSIDE GROUND WATER BASIN
WITHIN SAN BERNARDINO COUNTY FOR PERIOD 1971 THROUGH CURRENT YEAR
AND PRODUCTION DELIVERED IN RIVERSIDE AND SAN BERNARDINO COUNTIES

(Quantities in Acre Feet)

Year	Production		Total Production See note
	1S/5W36-C11S 3600535- Well #3	1S/5W-36C10S 3600536 Well # 1 1/2	
Base Period Average	60	693	753
1971	94	0	94
1972	376	0	376
1973	200	0	200
1974	402	-	402
1975	592	-	592
1976	637	-	637
1977	756	-	756
1978	1,118	-	1,118
1979	421	-	421
1980	478	-	478
1981	62	-	62
1982	793	-	793
1983	351	-	351
1984	634	-	634
1985	1,217	-	1,217
1986	1,372	-	1,372
1987	1,083	-	1,083
1988	26	-	26
1989	248	-	248
1990	392	-	392
1991	646	-	646
1992	357	-	357
1993	362	-	362
1994	413	-	413
1995	1,520	-	1,520
1996	1,500	-	1,500
1997	6	Overlying Land use only after 1997	6
1998	6	-	6
1999	1	-	1
2000	1	-	1
2001	1	-	1
2002	1	-	1
2003	1	-	1
2004	-	-	-
2005	34	-	34

~~Note: Total Production shown in Col. (3) is all exported to Riverside county via West Riverside Canal. Deliveries to San Bernardino County are zero.~~

FOR YEARS PRECEDING 1971: Refer to Volume 5, August 1976, Page III-17.

*Abandoned and/or file closed.

Canal was removed at the Agua Mansa Landfill in 1997, water truck only usage

** Sold to Yeager Construction Company in 1997, Agua Mansa Properties

TABLE NO. 45

AGUA MANSA PROPERTIES (WAS JURUPA WATER COMPANY **)

WATER PRODUCTION FROM RIVERSIDE GROUND WATER BASIN
WITHIN SAN BERNARDINO COUNTY FOR PERIOD 1971 THROUGH CURRENT YEAR
AND PRODUCTION DELIVERED IN RIVERSIDE AND SAN BERNARDINO COUNTIES

(Quantities in Acre Feet)

Year	Production		Total Production See note
	1S5W36C11S 3600535- Well #3	1S5W36C10S 3600536 * Well # 1 1/2	
Base Period Average	60	693	753
2006	28	-	28
2007	25	-	25
2008	27	-	27
2009	29	-	29
2010	29	-	29
2011	28	-	28
2012	27	-	27
2013		-	
2014		-	
2015		-	
2016		-	
2017		-	
2018		-	
2019		-	
2020		-	
2021		-	
2022		-	
2023		-	
2024		-	
2025		-	
2026		-	
2027		-	
2028		-	
2029		-	
2030		-	
2031		-	
2032		-	
2033		-	
2034		-	
2035		-	
2036		-	
2037		-	
2038		-	
2039		-	
2040		-	

*Abandoned and/or file closed.

Canal was removed at the Agua Mansa Landfill in 1997, water truck only usage

** Sold to Yeager Construction Company in 1997, Agua Mansa Properties

This Table Feeds Table 52 , then 52A which becomes Vol 3, Table 4

TABLE NO. 46A

LA SIERRA WATER COMPANY
WATER PRODUCTION FROM COLTON BASIN AND
THAT PART OF RIVERSIDE BASIN LOCATED WITHIN SAN BERNARDINO COUNTY
 (Quantities in Acre Feet)

Year	1S4W18G		1S4W18F		TOTAL PRODUCTION		
	Colton # 15	La Sierra # 15	Colton # 17	La Sierra # 17	Colton	La Sierra	Total
	3601259	3602227	3601261	3602228	(5)	(6)	(7)
	(1)	(2)	(3)	(4)			
1971	137	267	116	860	253	1,127	1,380
1972	106	364	245	693	351	1,057	1,408
1973	158	466	369	440	527	906	1,433
1974	329	348	545	312	874	660	1,534
1975	292	69	194	559	486	628	1,114
1976	259	349	467	304	726	653	1,379
1977	314	202	452	304	766	506	1,272
1978	273	202	572	304	845	506	1,351
1979	612	184	1,184	351	1,796	535	2,331
1980	698	275	728	267	1,426	542	1,968
1981	447	229	763	312	1,210	541	1,751
1982	586	0	1,030	582	1,616	582	2,198
1983	537	236	909	316	1,446	552	1,998
1984	667	216	811	287	1,478	503	1,981
1985	306	150	725	340	1,031	490	1,521
1986	668	347	507	103	1,175	450	1,625
1987	1,018	201	1,088	317	2,106	518	2,624
1988	1,286	200	1,448	278	2,734	478	3,212
1989	968	242	667	242	1,635	484	2,119
1990	1,014	174	795	352	1,809	526	2,335
1991	1,143	286	888	222	2,031	508	2,539
1992	1,149	390	1,030	156	2,179	546	2,725
1993	990	377	846	313	1,836	690	2,526
1994	1,074	316	1,159	392	2,233	708	2,941
1995	994	715	992	822	1,986	1,537	3,523
1996	981	343	978	199	1,959	542	2,501
1997	739	0	1,311	0	2,050	0	2,050
1998	746	0	681	0	1,427	0	1,427
1999	726	0	1,070	0	1,796	0	1,796
2000	632	0	971	0	1,603	0	1,603
2001	773	0	830	0	1,603	0	1,603
2002	91	0	180	0	271	0	271
2003	160	0	339	0	499	0	499
2004	507	0	1,470	0	1,977	0	1,977
2005	729	0	846	0	1,575	0	1,575

(1) Table No. 1, Volum Note: Wells 1S/4W-18G and 1S/4W-18F beginning in 1964 were used by both La Sierra

(2) Table No. 1, Volume 2.

(3) Table No. 1, Volume 2.

(4) Table No. 1, Volume 2.

FOR YEARS PRECEDING 1971: Refer to Volume 5, August 1976, Page III-19.

TABLE NO. 46A

LA SIERRA WATER COMPANY
WATER PRODUCTION FROM COLTON BASIN AND
THAT PART OF RIVERSIDE BASIN LOCATED WITHIN SAN BERNARDINO COUNTY
 (Quantities in Acre Feet)

Year	Colton Basin Production				TOTAL PRODUCTION		
	1S4W18G		1S4W18F		Colton	La Sierra	Total
	Colton # 15	La Sierra # 15	Colton # 17	La Sierra # 17			
	3601259	3602227	3601261	3602228	(5)	(6)	(7)
(1)	(2)	(3)	(4)	(5)	(6)	(7)	
2006	875	-	325	-	1,200	-	1,200
2007	572	-	720	-	1,292	-	1,292
2008	537	-	1,414	-	1,951	-	1,951
2009	539	-	1,053	-	1,592	-	1,592
2010	650	-	1,304	-	1,954	-	1,954
2011	467	-	1,321	-	1,788	-	1,788
2012	607	-	1,152	-	1,759	-	1,759
2013	-	-	-	-	-	-	-
2014	-	-	-	-	-	-	-
2015	-	-	-	-	-	-	-
2016	-	-	-	-	-	-	-
2017	-	-	-	-	-	-	-
2018	-	-	-	-	-	-	-
2019	-	-	-	-	-	-	-
2020	-	-	-	-	-	-	-
2021	-	-	-	-	-	-	-
2022	-	-	-	-	-	-	-
2023	-	-	-	-	-	-	-
2024	-	-	-	-	-	-	-
2025	-	-	-	-	-	-	-
2026	-	-	-	-	-	-	-
2027	-	-	-	-	-	-	-
2028	-	-	-	-	-	-	-
2029	-	-	-	-	-	-	-
2030	-	-	-	-	-	-	-
2031	-	-	-	-	-	-	-
2032	-	-	-	-	-	-	-
2033	-	-	-	-	-	-	-
2034	-	-	-	-	-	-	-
2035	-	-	-	-	-	-	-
2036	-	-	-	-	-	-	-
2037	-	-	-	-	-	-	-
2038	-	-	-	-	-	-	-
2039	-	-	-	-	-	-	-
2040	-	-	-	-	-	-	-

(1) Table No. 1, Volume 1
 (2) Table No. 1, Volume 2.
 (3) Table No. 1, Volume 2.
 (4) Table No. 1, Volume 2.

Note: Wells 1S/4W-18G and 1S/4W-18F beginning in 1964 were used by both La Sierra Water Company and City of Colton under the different Recordation Numbers shown for the same wells.

FOR YEARS PRECEDING 1971: Refer to Volume 5, August 1976, Page III-19.

TABLE NO. 46B

LA SIERRA WATER COMPANY
WATER PRODUCTION FROM COLTON BASIN AND
THAT PART OF RIVERSIDE BASIN LOCATED WITHIN SAN BERNARDINO COUNTY
 (Quantities in Acre Feet)

State Well # Recordation # Local Desig.	1S4W32E01S 3601539 LS #1	1S4W32E03S 3601540 LS #2	1S4W32E06S 3601541 LS #4	1S4W32E05S 3601542 LS #5	1S4W32E02S 3601543 LS #6	1S4W32E07S 3601544 LS #7	1S4W32E11S 3601545 LS #8	1S4W32E09S 3601546 LS #10	1S4W32E10S 3601547 LS #9	1S4W29Q03S 3691486 Flume 4	1S4W29Q04S 3692486 Flume 6	La Sierra Production Riverside Basin
Year	(1)	(2)	(3)	(4)	(5)	(6)	(7)	(8)	(9)	(10)	(11)	(12)
1971	-	-	-	-	-	1,218	2,106	1,415	-	-	-	4,739
1972	-	-	-	-	-	1,330	2,178	1,201	-	-	-	4,709
1973	-	-	-	-	-	664	1,980	0	-	-	-	2,644
1974	-	-	-	-	-	0	1,932	1	-	-	-	1,933
1975	-	-	-	-	-	0	2,309	2	-	-	-	2,311
1976	-	-	-	-	-	0	2,682	0	-	-	-	2,682
1977	-	-	-	-	-	0	2,396	0	-	431	35	2,862
1978	-	-	-	-	-	0	1,496	0	-	3	1	1,500
1979	-	-	-	-	-	0	1,654	0	-	53	29	1,736
1980	-	-	-	-	-	98	1,004	0	-	0	0	1,102
1981	-	-	-	-	-	276	0	1,957	-	-	-	2,233
1982	-	-	-	-	-	0	0	29	-	-	-	29
1983	-	-	-	-	-	0	0	14	-	-	-	14
1984	-	-	-	-	-	0	0	0	-	-	-	0
1985	-	-	-	-	-	0	0	0	-	-	-	0
1986	-	-	-	-	-	0	0	0	-	-	-	0
1987	-	-	-	-	-	0	0	0	-	-	-	0
1988	-	-	-	-	-	0	0	0	-	-	-	0
1989	-	-	-	-	-	0	0	0	-	-	-	0
1990	-	-	-	-	-	0	0	0	-	-	-	0
1991	-	-	-	-	-	0	0	0	-	-	-	0
1992	-	-	-	-	-	0	0	-	-	-	-	0
1993	-	-	-	-	-	0	0	-	-	-	-	0
1994	-	-	-	-	-	0	0	-	-	-	-	0
1995	-	-	-	-	-	0	0	-	-	-	-	0
1996	-	-	-	-	-	0	0	-	-	-	-	0
1997	-	-	-	-	-	0	0	-	-	-	-	0
1998	-	-	-	-	-	0	0	-	-	-	-	0
1999	-	-	-	-	-	0	0	-	-	-	-	0
2000	-	-	-	-	-	0	0	-	-	-	-	0
2001	-	-	-	-	-	0	0	-	-	-	-	0
2002	-	-	-	-	-	0	0	-	-	-	-	0
2003	-	-	-	-	-	0	0	-	-	-	-	0
2004	-	-	-	-	-	0	0	-	-	-	-	0
2005	-	-	-	-	-	0	0	-	-	-	-	0

La Sierra Water Company ceased operations in 2006

Column (8) = LS #10 assigned to Southern Calif. Edison Co. Highgrove Steam Plant. (12) = Total of Column (1) thru (11).
 Columns (10) & (11) = Starting in 1976 part of the flow from the Flume Wells is leased from the City of Riverside Abandoned &/or Filed Closed.
 The amounts shown are La Sierra production only. Riverside production is shown under 3601886 & 3602486.

FOR YEARS PRECEDING 1971: Refer to Volume 5, August 1976, Page III-20.

TABLE NO. 47

LA SIERRA WATER COMPANY
WATER PRODUCTION FROM COLTON AND RIVERSIDE BASIN SITUATED WITHIN SAN BERNARDINO COUNTY
WITH DELIVERIES IN SAN BERNARDINO COUNTY AND EXPORTS TO RIVERSIDE COUNTY
 (Quantities in Acre Feet)

Year	La Sierra Production in Colton and Riverside North Basins			DELIVERIES OF LA SIERRA WATER COMPANY WATER PRODUCTION								
	Colton Basin	Riverside Basin	Total Production	Deliveries Made in San Bernardino County				Deliveries Made in Riverside County				
				So. California Edison Steam Plant	Riverside Highland Water Co.	City of Colton	Total in San Bernardino County	West Riverside Canal	Riverside Highland Water Co.	Temescal Water Company	City of Riverside	Total Deliveries in Riverside County
(2)	(3)	(4)	(5)	(6)	(7)	(8)	(9)	(10)	(11)	(12)	(13)	(14)
Base Period Average:	(a) & (b) -	2,573	2,573	441	76	(a) & (b) -	517	1,837	219	(c) -	-	2,056
1971	1,127	4,739	5,866	-	0	1,127	1,127	3,324	0	1,415		4,739
1972	1,057	4,709	5,766	-	0	1,057	1,057	3,508	0	1,201		4,709
1973	906	2,644	3,550	-	0	906	906	2,644	0	0		2,644
1974	660	1,933	2,593	-	0	660	660	1,932	0	1		1,933
1975	628	2,311	2,939	-	0	628	628	2,309	0	2		2,311
1976	653	2,682	3,335	-	0	653	653	2,682	0	0		2,682
1977	506	2,862	3,368	-	0	506	506	2,396	0		466	2,862
1978	506	1,500	2,006	-	0	506	506	1,496	0	0	4	1,500
1979	535	1,736	2,271	-	0	535	535	1,654	0	0	82	1,736
1980	542	1,102	1,644	-	0	542	542	1,102	0	0	0	1,102
1981	541	2,233	2,774	-	0	541	541	276	0	1,957	0	2,233
1982	582	29	611	-	0	582	582	0	0	29	0	29
1983	552	14	566	-	0	552	552	0	0	14	0	14
1984	503	0	503	-	0	503	503	0	0	0	0	0
1985	490	0	490	-	0	490	490	0	0	0	0	0
1986	450	0	450	-	0	450	450	0	0	0	0	0
1987	518	0	518	-	0	518	518	0	0	0	0	0
1988	478	0	478	-	0	478	478	0	0	0	0	0
1989	484	0	484	-	0	484	484	0	0	0	0	0
1990	526	0	526	-	0	526	526	0	0	0	0	0
1991	508	0	508	-	0	508	508	0	0	0	0	0
1992	546	0	546	-	0	546	546	0	0	0	0	0
1993	690	0	690	-	0	690	690	0	0	0	0	0
1994	708	0	708	-	0	708	708	0	0	0	0	0
1995	1,537	0	1,537	-	0	1,537	1,537	0	0	0	0	0
1996	542	0	542	-	0	542	542	0	0	0	0	0
1997	0	0	0	-	0	0	0	0	0	0	0	0
1998	0	0	0	-	0	0	0	0	0	0	0	0
1999	0	0	0	-	0	0	0	0	0	0	0	0
2000	0	0	0	-	0	0	0	0	0	0	0	0
2001	0	0	0	-	0	0	0	0	0	0	0	0
2002	0	0	0	-	0	0	0	0	0	0	0	0
2003	0	0	0	-	0	0	0	0	0	0	0	0
2004	0	0	0	-	0	0	0	0	0	0	0	0
2005	0	0	0	-	1	0	0	0	0	0	0	0

La Sierra Water Company ceased operations in 2006

Column (3) = From Table No. 46A Col. (6).
 Column (4) = From Table No. 46B Col. (12).
 Column (5) = Col. (3) + (4).
 Column (6) = See General Note (c).
 Column (7) = Table No. 31, Col. (8), Riverside Highland Wtr. Co.
 Column (8) = Identical to this Table No. 47, Col. (3).
 Column (9) = Total of Columns (5), (6), & (7).
 Column (10) = 1964 and after: Col. (5) - [Col. (6) + (7) + (8) + (12) + (13)].
 Column (11) = Table No. 31, Col. (17), Riverside Highland Wtr. Co.
 Column (12) = 1964 and after, see Temescal File.
 Column (13) = From Table No. 46B, Cols. (10) + (11).
 Column (14) = Total of Cols. (10), (11), (12), & (13).

General Notes:

- (a) Production shown is from Well 1S/4W-18G. This well is owned by City of Colton and no production from this well was made by La Sierra Water Co. prior to 1964. Beginning in 1964, production by Colton recorded under 3601259 and by La Sierra under 3602227.
- (b) Production shown includes water from 1S/4W-18F. This well is owned by the City of Colton and no production from this well was made by La Sierra prior to 1964. Beginning in 1964, production by Colton recorded under 3601261 and by La Sierra under 3602228.
- (c) La Sierra Well No. 10 delivered directly to Edison steam Plant in Highgrove 1959-63. Beginning in 1964, Temescal Water Co. in Riverside County purchased the flow of La Sierra No. 10 Well from Southern California Edison Company.

FOR YEARS PRECEDING 1971: Refer to Volume 5, August 1976, Page III-21.

Base Period Average from Base Period Report, page 506

TABLE NO. 48LA SIERRA WATER COMPANY

WATER PRODUCTION FROM RIVERSIDE GROUND WATER BASIN
WITHIN SAN BERNARDINO COUNTY FOR PERIOD 1971 THROUGH CURRENT YEAR
AND PRODUCTION DELIVERED IN RIVERSIDE AND SAN BERNARDINO COUNTIES

(Quantities in Acre Feet)

Year	Total Production	Used in San Bernardino County	Exported to Riverside County
	(1)	(2)	(3)
Base Period Average	2,573	517	2,056
1971	4,739	0	4,739
1972	4,709	0	4,709
1973	2,644	0	2,644
1974	1,933	0	1,933
1975	2,311	0	2,311
1976	2,682	0	2,682
1977	2,862	0	2,862
1978	1,500	0	1,500
1979	1,736	0	1,736
1980	1,102	0	1,102
1981	2,233	0	2,233
1982	29	0	29
1983	14	0	14
1984	0	0	0
1985	0	0	0
1986	0	0	0
1987	0	0	0
1988	0	0	0
1989	0	0	0
1990	0	0	0
1991	0	0	0
1992	0	0	0
1993	0	0	0
1994	0	0	0
1995	0	0	0
1996	0	0	0
1997	0	0	0
1998	0	0	0
1999	0	0	0
2000	0	0	0
2001	0	0	0
2002	0	0	0
2003	0	0	0
2004	0	0	0
2005	0	0	0

La Sierra Water Company ceased operations in 2006

Column (1) = From Col. (4) Table No. 47.

Column (2) = Col. (4) - [Cols. (10) + (11) + (12) + (13)], Table No. 47.

Column (3) = From Col. (14), Table No. 47.

FOR YEARS PRECEDING 1971: Refer to Volume 5, August 1976, Page III-23.

Base Period Average from Base Period Report, Table 48, page 507

TABLE NO. 49

page 1 of 2

RIVERSIDE HIGHLAND WATER COMPANY
WATER PRODUCTION FROM RIVERSIDE GROUND WATER BASIN
WITHIN SAN BERNARDINO COUNTY FOR PERIOD 1971 THROUGH CURRENT YEAR
AND PRODUCTION DELIVERED IN RIVERSIDE AND SAN BERNARDINO COUNTIES
(Quantities in Acre Feet)

Year	Total Production (1)	Export to Riverside County (2)	Used in San Bernardino County (3)
Base Period Average	3,752	2,654	1,098
1971	5,304	3,778	1,526
1972	4,229	2,980	1,249
1973	4,074	2,847	1,227
1974	3,371	2,262	1,109
1975	3,016	2,050	966
1976	3,592	2,484	1,108
1977	4,699	3,582	1,117
1978	3,923	2,621	1,302
1979	3,876	2,682	1,194
1980	4,284	2,837	1,447
1981	4,965	3,289	1,676
1982	3,330	2,089	1,248
1983	2,536	1,646	889
1984	4,545	3,178	1,367
1985	4,475	3,176	1,299
1986	2,089	1,088	1,001
1987	1,632	1,054	578
1988	1,785	1,072	713
1989	2,558	1,000	1,558
1990	2,858	1,242	1,616
1991	3,581	1,603	1,978
1992	2,215	971	1,244
1993	3,034	1,370	1,664
1994	3,285	1,613	1,672
1995	3,126	1,430	1,696
1996	2,396	1,088	1,308
1997	2,513	1,161	1,352
1998	2,195	871	1,324
1999	2,627	761	1,866
2000	1,138	18	1,120
2001	1,341	61	1,280
2002	2,577	137	2,440
2003	1,885	187	1,698
2004	2,793	294	2,499
2005	2,031	195	1,836

Column (1) = From Table No. 21, Col. (10).

Column (2) = T 31, Col. (16); after 1989, Table 23R, Sheet 2, Column (11).

Column (3) = T 31, Col. (7); after 1989, Table 23R, Sheet 2, Column (10).

* New RH well RN #7 backfiled for 2001

Base Period Averages from Base Period Report, Table 49, page 508
FOR YEARS PRECEDING 1971: Refer to Volume 5, 1976, Page III-25

TABLE NO. 49

RIVERSIDE HIGHLAND WATER COMPANY
WATER PRODUCTION FROM RIVERSIDE GROUND WATER BASIN
WITHIN SAN BERNARDINO COUNTY FOR PERIOD 1971 THROUGH CURRENT YEAR
AND PRODUCTION DELIVERED IN RIVERSIDE AND SAN BERNARDINO COUNTIES
 (Quantities in Acre Feet)

Year	Total Production	Export to Riverside County	Used in San Bernardino County
	(1)	(2)	(3)
Base Period Average	3,752	2,654	1,098
2006	1,199	88	1,111
2007	2,136	236	1,900
2008	1,583	163	1,420
2009	2,617	292	2,325
2010	2,909	281	2,628
2011	2,439	257	2,182
2012	2,271	231	2,040
2013			
2014			
2015			
2016			
2017			
2018			
2019			
2020			
2021			
2022			
2023			
2024			
2025			
2026			
2027			
2028			
2029			
2030			
2031			
2032			
2033			
2034			
2035			
2036			
2037			
2038			
2039			
2040			

Column (1) = From Table No. 21, Col. (10).

Column (2) = T 31, Col. (16); after 1989, Table 23R, Sheet 2, Column (11).

Column (3) = T 31, Col. (7); after 1989, Table 23R, Sheet 2, Column (10).

* New RH well RN #7 backfiled for 2001

Base Period Averages from Base Period Report, Table 49, page 508

FOR YEARS PRECEDING 1971: Refer to Volume 5, 1976, Page III-25

TABLE NO. 50

Page 1 of 2

TEMESCAL WATER COMPANY
(Elsinore Valley M.W.D. after 1995)

WATER PRODUCTION FROM RIVERSIDE GROUNDWATER BASIN
WITHIN SAN BERNARDINO COUNTY FOR PERIOD 1971 THROUGH CURRENT YEAR
AND PRODUCTION DELIVERED IN RIVERSIDE AND SAN BERNARDINO COUNTIES
(Quantities in Acre Feet)

Palm Ave. Well	
State Well#	Recordation #
2S/4W-06A03S	3601509
	(1)
Year	Production
<u>Base Period Average</u>	<u>1,263</u>
1971	1,948
1972	1,368
1973	1,614
1974	821
1975	2,035
1976	2,682
1977	2,363
1978	1,528
1979	2,130
1980	1,968
1981	2,196
1982	1,423
1983	0
1984	1,190
1985	1,817
1986	2,051
1987	1,878
1988	2,360
1989	2,790
1990	2,283
1991	2,354
1992	1,714
1993	1,698
1994	0
1995	556
1996	25
1997	97
1998	194
1999	0
2000	1,037
2001	252
2002	2,417
2003	1,299
2004	159
2005	1

Note: Total production shown in column (1) is all exported to Riverside County via Gage or Riverside Canals. Deliveries in San Bernardino County are zero. No deliveries made via Gage since conversion to domestic pipeline in 1975. FOR YEARS PRECEDING 1971: Refer to Volume 5, August 1976, Page III-27.

Base Period Average from Base Period Report, Table 50, page 509

TABLE NO. 50

ELSINORE VALLEY MWD

(Was Temescal Water Company before 1995)

WATER PRODUCTION FROM RIVERSIDE GROUNDWATER BASIN
WITHIN SAN BERNARDINO COUNTY FOR PERIOD 1971 THROUGH CURRENT YEAR
AND PRODUCTION DELIVERED IN RIVERSIDE AND SAN BERNARDINO COUNTIES
 (Quantities in Acre Feet)

Palm Avenue Well	
State Well #	Recordation #
02S/04W-06A03S	3601509
	(1)
Year	Production
Base Period Average	1,263
2006	515
2007	788
2008	2,043
2009	1,010
2010	0
2011	8
2012	0
2013	
2014	
2015	
2016	
2017	
2018	
2019	
2020	
2021	
2022	
2023	
2024	
2025	
2026	
2027	
2028	
2029	
2030	
2031	
2032	
2033	
2034	
2035	
2036	
2037	
2038	
2039	
2040	

See Table 3, Volume 3 for production

Note: Total production shown in column (1) is all exported to Riverside County via the Riverside Canals. Deliveries in San Bernardino County are zero.

No deliveries made via Gage since conversion to domestic pipeline in 1975.

FOR YEARS PRECEDING 1971: Refer to Volume 5, August 1976, Page III-27.

Base Period Average from Base Period Report, Table 51, page 509

TABLE NO. 51

Page 1 of 2

WEST RIVERSIDE 350 INCH WATER COMPANY
WATER PRODUCTION FROM RIVERSIDE GROUND WATER BASIN
WITHIN SAN BERNARDINO COUNTY FOR PERIOD 1971 THROUGH CURRENT YEAR
(Quantities in Acre Feet)

Year	1S4W32B01S 3600832 Well # 5	1S4W32B02S 3601953 Well # 7	Total Production
<u>Base Period Average</u>			<u>2,419</u>
1971	470	1,749	2,219
1972	225	1,908	2,133
1973	197	688	885
1974	218	1,240	1,521
1975	228	1,298	1,526
1976	84	897	981
1977	262	321	583
1978	233	183	416
1979	139	750	889
1980	454	131	585
1981	611	784	1,395
1982	641	264	905
1983	6	40	46
1984	0	0	0
1985	155	430	585
1986	0	0	0
1987	0	0	0
1988	0	0	0
1989	0	0	0
1990	0	0	0
1991	0	0	0
1992	0	0	0
*1993	1	1	0
*1994	1	1	0
1995	0	0	0
1996	0	0	0
1997	0	0	0
1998	0	0	0
1999	0	0	0
2000	0	0	0
2001	0	0	0
2002	0	0	0
2003	0	0	0
2004	0	0	0
2005	0	0	0

Col (1) & (2) From Table No. 1, Volume 3.

Col. (3) = Cols. (1) + (2).

Note: Total production shown in Col. (3) is all exported to Riverside County via West Riverside Canal. Deliveries in San Bernardino County are zero.

Wells 1, 2, 4, 6 are abandoned.

FOR YEARS PRECEDING 1971: Refer to Volume 5, August 1976, Page III-29.

* Wells pump tested, no water exported

Base Period Average from Base Period Report, Table 51, page 510

TABLE NO. 51

EMPIRE WATER (was West Riverside 350 Inch Water Co.)
WATER PRODUCTION FROM RIVERSIDE GROUND WATER BASIN
WITHIN SAN BERNARDINO COUNTY FOR PERIOD 1971 THROUGH CURRENT YEAR

(Quantities in Acre Feet)

Year	01S/04W-32B01S 3600832 Well # 5	01S/04W-32B02S 3601953 Well # 7	Total Production
Base Period Average			2,419
2006	0	0	0
2007	0	0	0
2008	0	0	0
2009	0	0	0
2010	0	0	0
2011	0	0	0
2012	0	0	0
2013			
2014			
2015			
2016			
2017			
2018			
2019			
2020			
2021			
2022			
2023			
2024			
2025			
2026			
2027			
2028			
2029			
2030			
2031			
2032			
2033			
2034			
2035			
2036			
2037			
2038			
2039			
2040			

Col (1) & (2) From Table No. 1, Volume 3.

Col. (3) = Cols. (1) + (2).

Note: Total production shown in Col. (3) is all exported to Riverside County via West Riverside Canal. Deliveries in San Bernardino County are zero. Wells 1, 2, 4, 6 are abandoned.

FOR YEARS PRECEDING 1971: Refer to Volume 5, August 1976, Page III-29.

Base Period Average from Base Period Report, Table 51, page 510

TABLE NO. 52

GROUNDWATER PRODUCTION FROM THAT PART OF THE RIVERSIDE GROUNDWATER BASIN SITUATED WITHIN SAN BERNARDINO COUNTY
A PART OF WHICH IS USED IN SAN BERNARDINO COUNTY AND THE REMAINDER EXPORTED TO
RIVERSIDE COUNTY DURING THE FIVE-YEAR YEAR BASE PERIOD ENDING IN 1963

-- Updated through 1970 --

(Quantities in Acre Feet)

Line #	Description	Year					Total	Five Year Average	Notes
		1959	1960	1961	1962	1963			
<u>Water Production used in San Bernardino County</u>									
1	American Cement Company	713	719	832	510	298	3,072	614	From Table # 41, Column (2)
2	City of Riverside, Domestic & Irrigation	1581	852	1171	81	84	3,769	754	From Table # 42, Column (2)
3	City of Riverside, "The Gage Canal"	0	0	0	0	0	0	0	From Table # 43, Column (2)
4	West Valley Water District (was Inter-County Water)	57	55	52	46	51	261	52	From Table # 44, Column (3)
5	Agua Mansa Properties (was Jurupa Water Co.)	0	0	0	0	0	0	0	From Table # 45, See footnote
6	La Sierra Water Company	725	698	598	289	274	2,584	517	From Table # 48, Column (2)
7	Riverside Highland Water Company	1,317	890	994	1,043	1,246	5,490	1,098	From Table # 49, Column (3)
8	Elsinore Valley MWD (was Temescal Water Co)	0	0	0	0	0	0	0	From Table # 50, See footnote
9	West Riverside 350" Water Company	0	0	0	0	0	0	0	From Table # 51, See footnote
10	TOTAL LINES 1 THROUGH 9	4,393	3,214	3,647	1,969	1,953	15,176	3,035	
11									
12									
13									
14	<u>Water Production Export to Riverside County</u>								
15	American Cement Company	1,813	1,459	314	543	650	4,779	956	From Table # 41, Column (1)
16	City of Riverside, Domestic & Irrigation	11,393	8,787	10,508	8,634	8,175	47,497	9,499	From Table # 42, Column (1)
17	City of Riverside, "The Gage Canal"	1,504	1,474	1,639	1,231	1,169	7,017	1,403	From Table # 43, Column (1)
18	West Valley Water District (was Inter-County Water)	88	86	81	71	80	406	81	From Table # 44, Column (4)
19	Agua Mansa Properties (was Jurupa Water Co.)	811	762	1,114	745	333	3,765	753	From Table # 45, Column (3)
20	La Sierra Water Company	2,738	2,492	2,789	1,572	690	10,281	2,056	From Table # 48, Column (3)
21	Riverside Highland Water Company	2,484	2,489	3,110	2,537	2,652	13,272	2,654	From Table # 49, Column (2)
22	Elsinore Valley MWD (was Temescal Water Co)	1203	1319	1,363	1,163	1265	6,313	1,263	From Table # 50, Column (1)
23	West Riverside 350" Water Company	2295	1972	2148	2989	2692	12,096	2,419	From Table # 51, Column (3)
24	TOTAL LINES 15 THROUGH 23	24,329	20,840	23,066	19,485	17,706	105,426	21,085	
25	TOTAL LINES 10 plus 24	28,722	24,054	26,713	21,454	19,659	120,602	24,120	

FOR YEARS PRECEDING 1976: Refer to Volume 5-1975, August 1977, Page 56.

Inter-County Water Company was taken over in 1988 by West San Bernardino County Water District.

TABLE NO. 52

GROUNDWATER PRODUCTION FROM THAT PART OF THE RIVERSIDE GROUNDWATER BASIN SITUATED WITHIN SAN BERNARDINO COUNTY
A PART OF WHICH IS USED IN SAN BERNARDINO COUNTY AND THE REMAINDER EXPORTED TO
RIVERSIDE COUNTY DURING CALENDAR YEARS 1976 THROUGH CURRENT YEAR

(Quantities in Acre Feet)

Line #		1971	1972	1973	1974	1975	Total	Five Year Average		
	<u>Water Production used in San Bernardino County</u>									
1	American Cement Company	482	204	0	0	0	686	137	From Table No. 41, Column (2).	
2	City of Riverside, Domestic & Irrigation	174	107	45	111	94	531	106	From Table No. 42, Column (2).	
3	City of Riverside, "The Gage Canal"	0	0	0	98	77	175	35	From Table No. 43, Column (2).	
4	Inter-County Water (W.S.B.C.W.D.)	32	37	61	81	88	299	60	From Table No. 44, Column (3).	
5	Jurupa Water Company	-	-	-	-	-	0	0	From Table No. 45, See footnote.	
6	La Sierra Water Company	0	0	0	0	0	0	0	From Table No. 48, Column (2).	
7	Riverside Highland Water Company	1,526	1,249	1,227	1,109	966	6,077	1,215	From Table No. 49, Column (3).	
8	Temescal Water Company	-	-	-	-	-	0	0	From Table No. 50, See footnote.	
9	West Riverside 350" Water Company	-	-	-	-	-	0	0	From Table No. 51, See footnote.	
10	TOTAL LINES 1 THROUGH 9	2,214	1,597	1,333	1,399	1,225	7,768	1,554		
11										
12										
13										
14	<u>Water Production Export to Riverside County</u>									
15	American Cement Company	349	373	537	133	0	1,392	278	From Table No. 41, Column (1).	
16	City of Riverside, Domestic & Irrigation	4,363	5,813	4,941	6,012	5,744	26,873	5,375	From Table No. 42, Column (1).	
17	City of Riverside, "The Gage Canal"	567	778	222	374	568	2,509	502	From Table No. 43, Column (1).	
18	Inter-County Water (W.S.B.C.W.D.)	51	58	96	125	137	467	93	From Table No. 44, Col (2).	
19	Jurupa Water Company	94	376	200	402	592	1,664	333	From Table No. 45, Column (3).	
20	La Sierra Water Company	4,739	4,709	2,644	1,933	2,311	16,336	3,267	From Table No. 48, Column (3).	
21	Riverside Highland Water Company	3,778	2,980	2,847	2,262	2,050	13,917	2,783	From Table No. 49, Column (2).	
22	Temescal Water Company	1,948	1,368	1,614	821	2,035	7,786	1,557	From Table No. 50, Column (1).	
23	West Riverside 350" Water Company	2,219	2,133	885	1,521	1,526	8,284	1,657	From Table No. 51, Column (3).	
24	TOTAL LINES 15 THROUGH 23	18,108	18,588	13,986	13,583	14,963	79,228	15,846		
25	TOTAL LINES 10 plus 24	20,322	20,185	15,319	14,982	16,188	86,996	17,399		

FOR YEARS PRECEDING 1976: Refer to Volume 5-1975, August 1977, Page 56.

TABLE NO. 52

GROUNDWATER PRODUCTION FROM THAT PART OF THE RIVERSIDE GROUNDWATER BASIN SITUATED WITHIN SAN BERNARDINO COUNTY
A PART OF WHICH IS USED IN SAN BERNARDINO COUNTY AND THE REMAINDER EXPORTED TO
RIVERSIDE COUNTY DURING CALENDAR YEARS 1976 THROUGH CURRENT YEAR

(Quantities in Acre Feet)

	1976	1977	1978	1979	1980	1981	1982	1983	1984	1985	
Line #	Water Production used in San Bernardino County										
1	218	446	227	436	218	413	0	0	0	0	From Table No. 41, Column (2).
2	126	279	271	587	1,591	1,526	2,102	1,933	448	714	From Table No. 42, Column (2).
3	62	6	4	4	4	3	1	1	2	1	From Table No. 43, Column (2).
4	152	137	96	149	150	115	132	102	136	129	From Table No. 44, Column (3).
5	-	-	-	-	-	-	-	-	-	-	From Table No. 45, See footnote.
6	0	0	0	0	0	0	0	0	0	0	From Table No. 48, Column (2).
7	1,108	1,117	1,302	1,194	1,447	1,676	1,248	889	1,367	1,299	From Table No. 49, Column (3).
8	-	-	-	-	-	-	-	-	-	-	From Table No. 50, See footnote.
9	-	-	-	-	-	-	-	-	-	-	From Table No. 51, See footnote.
10	1,666	1,985	1,900	2,370	3,410	3,733	3,483	2,925	1,953	2,143	
11											
12											
13											
14	Water Production Export to Riverside County										
15	0	0	0	0	0	0	0	0	0	0	From Table No. 41, Column (1).
16	6,219	3,833	1,093	2,249	115	1,368	1,513	648	2,443	2,479	From Table No. 42, Column (1).
17	378	383	730	409	2,028	2,464	1,644	1,018	2,044	1,860	From Table No. 43, Column (1).
18	78	70	49	76	78	60	68	52	71	67	From Table No. 44, Col (2)
19	637	756	1,118	421	478	62	793	351	634	1,217	From Table No. 45, Column (3).
20	2,682	2,862	1,500	1,736	1,102	2,233	29	14	0	0	From Table No. 48, Column (3).
21	2,484	3,582	2,621	2,682	2,837	3,289	2,089	1,646	3,178	3,176	From Table No. 49, Column (2).
22	2,682	2,363	1,528	2,130	1,968	2,196	1,423	0	1,190	1,817	From Table No. 50, Column (1).
23	981	583	416	889	585	1,395	905	46	0	585	From Table No. 51, Column (3).
24	16,141	14,432	9,055	10,592	9,191	13,067	8,464	3,775	9,560	11,201	
25	17,807	16,417	10,955	12,962	12,601	16,800	11,947	6,700	11,513	13,344	

FOR YEARS PRECEDING 1976: Refer to Volume 5-1975, August 1977, Page 56.

+ Name changed in 1981 from Amcord

TABLE NO. 52

GROUNDWATER PRODUCTION FROM THAT PART OF THE RIVERSIDE GROUNDWATER BASIN SITUATED WITHIN SAN BERNARDINO COUNTY
A PART OF WHICH IS USED IN SAN BERNARDINO COUNTY AND THE REMAINDER EXPORTED TO
RIVERSIDE COUNTY DURING CALENDAR YEARS 1976 THROUGH CURRENT YEAR

(Quantities in Acre Feet)

	1986	1987	1988	1989	1990	1991	1992	1993	1994	1995	
Line #	Water Production used in San Bernardino County										
1	0	0	0	-	-	-	-	-	-	-	From Table No. 41, Column (2).
2	117	87	58	59	1,011	1,005	334	69	72	0	From Table No. 42, Column (2).
3	2	1	2	2	1	1	1	2	2	0	From Table No. 43, Column (2).
4	125	51	0	0	0	0	0	0	0	0	From Table No. 44, Column (3).
5	-	-	-	-	-	-	-	-	-	-	From Table No. 45, See footnote.
6	0	0	0	0	0	0	0	0	0	0	From Table No. 48, Column (2).
7	1,001	578	713	1,558	1,616	1,978	1,244	1,664	1,672	1,696	From Table No. 49, Column (3).
8	-	-	-	-	-	-	-	-	-	-	From Table No. 50, See footnote.
9	-	-	-	-	-	-	-	-	-	-	From Table No. 51, See footnote.
10	1,245	717	773	1,619	2,628	2,984	1,579	1,735	1,746	1,696	
11											
12											
13											
14	Water Production Export to Riverside County										
15	0	0	0	-	-	-	-	-	-	-	From Table No. 41, Column (1).
16	2,225	1,675	3,257	10,135	9,972	12,198	10,009	9,231	8,131	10,755	From Table No. 42, Column (1).
17	1,891	1,995	2,187	1,963	1,961	1,733	1,656	2,021	2,026	1,664	From Table No. 43, Column (1).
18	64	27	21	21	21	21	21	21	21	21	From Table No. 44, Col (2).
19	1,372	1,083	26	248	392	646	357	362	413	1,520	From Table No. 45, Column (3).
20	0	0	0	0	0	0	0	0	0	0	From Table No. 48, Column (3).
21	1,088	1,054	1,072	1,000	1,242	1,603	971	1,370	1,613	1,430	From Table No. 49, Column (2).
22	2,051	1,878	2,360	2,790	2,283	2,354	1,714	1,698	0	556	From Table No. 50, Column (1).
23	0	0	0	0	0	0	0	0	0	0	From Table No. 51, Column (3).
24	8,691	7,712	8,923	16,157	15,871	18,555	14,728	14,703	12,204	15,946	
25	9,936	8,429	9,696	17,776	18,499	21,539	16,307	16,438	13,950	17,642	

FOR YEARS PRECEDING 1976: Refer to Volume 5-1975, August 1977, Page 56.
Inter-County Water Company was taken over in 1988 by West San Bernardino County Water District.

TABLE NO. 52

GROUNDWATER PRODUCTION FROM THAT PART OF THE RIVERSIDE GROUNDWATER BASIN SITUATED WITHIN SAN BERNARDINO COUNTY
A PART OF WHICH IS USED IN SAN BERNARDINO COUNTY AND THE REMAINDER EXPORTED TO
RIVERSIDE COUNTY DURING CALENDAR YEARS 1976 THROUGH CURRENT YEAR.

Line #		(Quantities in Acre Feet)										
		1996	1997	1998	1999	2000	2001	2002	2003	2004	2005	
<u>Water Production used in San Bernardino County</u>												
1	Riverside Cement Company	-	-	-	-	-	-	-	-	-	-	From Table # 41, Column (2).
2	City of Riverside, Domestic & Irrigation	0	0	0	0	0	0	0	0	0	0	From Table # 42, Column (2).
3	City of Riverside, "The Gage Canal"	0	0	0	0	0	0	0	0	0	-	From Table # 43, Column (2).
4	Inter-County Water (W.S.B.C.W.D.)	-	-	-	-	-	-	-	-	-	-	From Table # 44, Column (3).
5	Jurupa Water Company	-	6	6	1	1	1	1	1	-	34	From Table # 45, See footnote.
6	La Sierra Water Company	0	0	0	0	0	0	0	0	0	0	From Table # 48, Column (2).
7	Riverside Highland Water Company	1,308	1,352	1,324	1,866	1,120	1,280	2,440	1,698	2,499	1,836	From Table # 49, Column (3).
8	Temescal Water Company	-	-	-	-	-	-	-	-	-	-	From Table # 50, See footnote.
9	West Riverside 350" Water Company	-	-	-	-	-	-	-	-	-	-	From Table # 51, See footnote.
10	TOTAL LINES 1 THROUGH 9	1,308	1,358	1,330	1,867	1,121	1,281	2,441	1,699	2,499	1,870	
11												
12												
13												
<u>Water Production Export to Riverside County</u>												
15	Riverside Cement Company	-	-	-	-	-	-	-	-	-	-	From Table # 41, Column (1).
16	City of Riverside, Domestic & Irrigation	9,064	8,169	6,765	8,883	8,629	7,288	7,814	6,390	5,123	7,829	From Table # 42, Column (1).
17	City of Riverside, "The Gage Canal"	1,706	1,591	1,823	2,051	1,664	1,491	1,286	1,339	1,125	1,354	From Table # 43, Column (1).
18	Inter-County Water (W.S.B.C.W.D.)	21	21	21	21	21	21	21	21	21	21	From Table # 44, Col (4)
19	Jurupa Water Company	1,500	-	-	-	-	-	-	-	0	-	From Table # 45, Column (3).
20	La Sierra Water Company	0	0	0	0	0	0	0	0	0	0	From Table # 48, Column (3).
21	Riverside Highland Water Company	1,088	1,161	871	761	18	61	137	187	294	195	From Table # 49, Column (2).
22	Temescal Water Company	25	97	194	0	1,037	252	2,417	1,299	159	1	From Table # 50, Column (1).
23	West Riverside 350" Water Company	0	0	0	0	0	0	0	0	0	0	From Table # 51, Column (3).
24	TOTAL LINES 15 THROUGH 23	13,404	11,039	9,674	11,716	11,369	9,113	11,675	9,236	6,722	9,400	
25	TOTAL LINES 10 plus 24	14,712	12,397	11,004	13,583	12,490	10,394	14,116	10,935	9,221	11,270	

FOR YEARS PRECEDING 1976: Refer to Volume 5-1975, August 1977, Page 56.

Inter-County Water Company was taken over in 1988 by West San Bernardino County Water District.

TABLE NO. 52

GROUNDWATER PRODUCTION FROM THAT PART OF THE RIVERSIDE GROUNDWATER BASIN SITUATED WITHIN SAN BERNARDINO COUNTY
A PART OF WHICH IS USED IN SAN BERNARDINO COUNTY AND THE REMAINDER EXPORTED TO
RIVERSIDE COUNTY DURING CALENDAR YEARS 1976 THROUGH CURRENT YEAR

Line #		(Quantities in Acre Feet)										
		2006	2007	2008	2009	2010	2011	2012	2013	2014		2015
Water Production used in San Bernardino County												
1	Riverside Cement Company	-	-	-	-	-	-	-	-	-	-	From Table # 41, Column (2)
2	City of Riverside, Domestic & Irrigation	0	0	0	0	0	0	0				From Table # 42, Column (2)
3	City of Riverside, "The Gage Canal"	-	-	-	-	-	-	-	-	-	-	From Table # 43, Column (2)
4	West Valley Water District (was Inter-County)	-	-	-	-	-	-	-	-	-	-	From Table # 44, Column (3)
5	Agua Mansa Properties (was Jurupa Water Co.)	28	25	27	29	29	28	27				From Table # 45, See footnote
6	La Sierra Water Company	-	-	-	-	-	-	-	-	-	-	From Table # 48, Column (2)
7	Riverside Highland Water Company	1,111	1,900	1,420	2,325	2,628	2,182	2,040				From Table # 49, Column (3)
8	Elsinore Valley MWD (was Temescal Water Co)	-	-	-	-	-	-	-	-	-	-	From Table # 50, See footnote
9	West Riverside 350" Water Company	-	-	-	-	-	-	-	-	-	-	From Table # 51, See footnote
10	TOTAL LINES 1 THROUGH 9	1,139	1,925	1,447	2,354	2,657	2,210	2,067				
11												
12												
13												
14	Water Production Export to Riverside County											
15	Riverside Cement Company	-	-	-	-	-	-	-	-	-	-	From Table # 41, Column (1)
16	City of Riverside, Domestic & Irrigation	10,276	5,688	8,802	13,614	11,045	12,043	13,876				From Table # 42, Column (1)
17	City of Riverside, "The Gage Canal"	1,969	1,870	1,849	1,601	1,074	693	1,304				From Table # 43, Column (1)
18	West Valley Water District (was Inter-County)	21	21	277	275	275	275	202				From Table # 44, Column (4)
19	Agua Mansa Properties (was Jurupa Water Co.)	-	-	-	-	-	-	-	-	-	-	From Table # 45, Column (3)
20	La Sierra Water Company	-	-	-	-	-	-	-	-	-	-	From Table # 48, Column (3)
21	Riverside Highland Water Company	88	236	163	292	281	257	231				From Table # 49, Column (2)
22	Elsinore Valley MWD (was Temescal Water Co)	515	788	2,043	1,010	0	8	0				From Table # 50, Column (1)
23	West Riverside 350" Water Company	0	0	0	0	0	0	0				From Table # 51, Column (3)
24	TOTAL LINES 15 THROUGH 23	12,869	8,603	13,134	16,792	12,675	13,276	15,613				
25	TOTAL LINES 10 plus 24	14,008	10,528	14,581	19,146	15,332	15,486	17,680				

FOR YEARS PRECEDING 1976: Refer to Volume 5-1975, August 1977, Page 56.

Inter-County Water Company was taken over in 1988 by West San Bernardino County Water District.

Corrected during the 2011 verification (West Valley WD delivery to new laundry facility, Rubidoux CSD handles wastewater flows)

TABLE NO. 52-A

GROUNDWATER PRODUCTION FROM THAT PART OF THE RIVERSIDE GROUNDWATER BASIN SITUATED
 WITHIN SAN BERNARDINO COUNTY, A PART OF WHICH IS USED IN
 SAN BERNARDINO COUNTY AND THE REMAINDER EXPORTED TO RIVERSIDE COUNTY DURING
 THE FIVE YEAR BASE PERIOD 1959-1963

CLASSIFIED ACCORDING TO SERVICE AREA
 (All Values in Acre Feet)

EXTRACTIONS FROM RIVERSIDE BASIN AREA WITHIN SAN BERNARDINO COUNTY FOR USE WITHIN AND EXPORT THEREFROM

PLAINTIFFS	1959			1960			1961			1962			1963			5-YEAR AVERAGE		
	Total Extract	Deliveries		Total Extract	Deliveries		Total Extract	Deliveries		Total Extract	Deliveries		Total Extract	Deliveries		Total Extract	Deliveries	
		Del. in S.B. Co.	Del. in Riv. Co.		Del. in S.B. Co.	Del. in Riv. Co.		Del. in S.B. Co.	Del. in Riv. Co.		Del. in S.B. Co.	Del. in Riv. Co.		Del. in S.B. Co.	Del. in Riv. Co.			
American Cement Co.	2,526	713	1,813	2,178	719	1,459	1,146	832	314	1,053	510	543	948	298	650	1,570	614	956
City of Riverside Domestic & irrigation	12,974	1,581	11,393	9,639	852	8,787	11,679	1,171	10,508	8,715	81	8,634	8,259	84	8,175	10,254	754	9,500
City of Riverside Gage Canal Company	1,504	0	1,504	1,474	0	1,474	1,639	0	1,639	1,231	0	1,231	1,169	0	1,169	1,403	0	1,403
Inter County Water Co.	145	57	88	141	55	86	133	52	81	117	46	71	131	51	80	133	52	81
Jurupa Water Company	811	0	811	762	0	762	1,114	0	1,114	745	0	745	333	0	333	753	0	753
La Sierra Water Company	3,463	725	2,738	3,190	698	2,492	3,387	598	2,789	1,861	289	1,572	964	274	690	2,573	517	2,056
Riverside Highland Water Company	3,801	1,317	2,484	3,379	890	2,489	4,104	994	3,110	3,580	1,043	2,537	3,898	1,246	2,652	3,752	1,098	2,654
Temescal Water Company	1,203	0	1,203	1,319	0	1,319	1,363	0	1,363	1,163	0	1,163	1,265	0	1,265	1,263	0	1,263
West Riverside 350" Water Company	2,295	0	2,295	1,972	0	1,972	2,148	0	2,148	2,989	0	2,989	2,692	0	2,692	2,419	0	2,419
TOTALS	28,722	4,393	24,329	24,054	3,214	20,840	26,713	3,647	23,066	21,454	1,969	19,485	19,659	1,953	17,706	24,120	3,035	21,085

Total Extract -- TOTAL EXTRACTIONS
 Del in S.B. Co. -- DELIVERY WITHIN SAN BERNARDINO COUNTY
 Del. in Riv. Co. -- DELIVERY WITHIN RIVERSIDE COUNTY

FOR YEARS PRECEDING 1976: Refer to Volume 5-1975, August 1976, Page 57
 From 52, Same as Volume 3, Table 4

TABLE NO. 52-A

GROUNDWATER PRODUCTION FROM THAT PART OF THE RIVERSIDE GROUNDWATER BASIN SITUATED
WITHIN SAN BERNARDINO COUNTY, A PART OF WHICH IS USED IN
SAN BERNARDINO COUNTY AND THE REMAINDER EXPORTED TO RIVERSIDE COUNTY DURING
CALENDAR YEARS 1971 THROUGH 1975

CLASSIFIED ACCORDING TO SERVICE AREA
(All Values in Acre Feet)

EXTRACTIONS FROM RIVERSIDE BASIN AREA WITHIN SAN BERNARDINO COUNTY FOR USE WITHIN AND EXPORT THEREFROM

PLAINTIFFS	1971			1972			1973			1974			1975		
	Total Extract	Deliveries		Total Extract	Deliveries		Total Extract	Deliveries		Total Extract	Deliveries		Total Extract	Deliveries	
		Del. in S.B. Co.	Del. in Riv. Co.		Del. in S.B. Co.	Del. in Riv. Co.		Del. in S.B. Co.	Del. in Riv. Co.		Del. in S.B. Co.	Del. in Riv. Co.			
American Cement Co.	831	482	349	577	204	373	537	0	537	133	0	133	0	0	0
City of Riverside Domestic & irrigation	4,537	174	4,363	5,920	107	5,813	4,986	45	4,941	6,123	111	6,012	5,838	94	5,744
City of Riverside Gage Canal Company	567	0	567	778	0	778	222	0	222	472	98	374	645	77	568
Inter County Water Co.	83	32	51	95	37	58	157	61	96	206	81	125	225	88	137
Jurupa Water Company	94	-	94	376	-	376	200	-	200	402	-	402	592	-	592
La Sierra Water Company	4,739	0	4,739	4,709	0	4,709	2,644	0	2,644	1,933	0	1,933	2,311	0	2,311
Riverside Highland Water Company	5,304	1,526	3,778	4,229	1,249	2,980	4,074	1,227	2,847	3,371	1,109	2,262	3,016	966	2,050
Temescal Water Company	1,948	-	1,948	1,368	-	1,368	1,614	-	1,614	821	-	821	2,035	-	2,035
West Riverside 350" Water Company	2,219	-	2,219	2,133	-	2,133	885	-	885	1,521	-	1,521	1,526	-	1,526
TOTALS	20,322	2,214	18,108	20,185	1,597	18,588	15,319	1,333	13,986	14,982	1,399	13,583	16,188	1,225	14,963

Total Extract -- TOTAL EXTRACTIONS
Del in S.B. Co. -- DELIVERY WITHIN SAN BERNARDINO COUNTY
Del. in Riv. Co. -- DELIVERY WITHIN RIVERSIDE COUNTY

From 52, Same as Table 4, Volume 3

TABLE NO. 52-A

GROUNDWATER PRODUCTION FROM THAT PART OF THE RIVERSIDE GROUNDWATER BASIN SITUATED
WITHIN SAN BERNARDINO COUNTY, A PART OF WHICH IS USED IN
SAN BERNARDINO COUNTY AND THE REMAINDER EXPORTED TO RIVERSIDE COUNTY DURING
CALENDAR YEARS 1976 THROUGH THE CURRENT YEAR

CLASSIFIED ACCORDING TO SERVICE AREA
(All Values in Acre Feet)

EXTRACTIONS FROM RIVERSIDE BASIN AREA WITHIN SAN BERNARDINO COUNTY FOR USE WITHIN AND EXPORT THEREFROM

PLAINTIFFS	1976			1977			1978			1979			1980		
	Total Extract	Deliveries		Total Extract	Deliveries		Total Extract	Deliveries		Total Extract	Deliveries		Total Extract	Deliveries	
		Del. in S.B. Co.	Del. in Riv. Co.		Del. in S.B. Co.	Del. in Riv. Co.		Del. in S.B. Co.	Del. in Riv. Co.		Del. in S.B. Co.	Del. in Riv. Co.			
American Cement Co.	218	218	0	446	446	0	227	227	0	436	436	0	218	218	0
City of Riverside Domestic & irrigation	6,345	126	6,219	4,112	279	3,833	1,364	271	1,093	2,836	587	2,249	1,706	1,591	115
City of Riverside Gage Canal Company	440	62	378	389	6	383	734	4	730	413	4	409	2,032	4	2,028
Inter County Water Co.	230	152	78	207	137	70	145	96	49	225	149	76	228	150	78
Jurupa Water Company	637	-	637	756	-	756	1,118	-	1,118	421	-	421	478	-	478
La Sierra Water Company	2,682	0	2,682	2,862	0	2,862	1,500	0	1,500	1,736	0	1,736	1,102	0	1,102
Riverside Highland Water Company	3,592	1,108	2,484	4,699	1,117	3,582	3,923	1,302	2,621	3,876	1,194	2,682	4,284	1,447	2,837
Temescal Water Company	2,682	-	2,682	2,363	-	2,363	1,528	-	1,528	2,130	-	2,130	1,968	-	1,968
West Riverside 350" Water Company	981	-	981	583	0	583	416	0	416	889	0	889	585	0	585
TOTALS	17,807	1,666	16,141	16,417	1,985	14,432	10,955	1,900	9,055	12,962	2,370	10,592	12,601	3,410	9,191

Total Extract -- TOTAL EXTRACTIONS

Del in S.B. Co. -- DELIVERY WITHIN SAN BERNARDINO COUNTY

Del. in Riv. Co. -- DELIVERY WITHIN RIVERSIDE COUNTY

FOR YEARS PRECEDING 1976: Refer to Volume 5-1975, August 1976, Page 57

From 52, Same as Table 4, Volume 3

TABLE NO. 52-A

GROUNDWATER PRODUCTION FROM THAT PART OF THE RIVERSIDE GROUNDWATER BASIN SITUATED
WITHIN SAN BERNARDINO COUNTY, A PART OF WHICH IS USED IN
SAN BERNARDINO COUNTY AND THE REMAINDER EXPORTED TO RIVERSIDE COUNTY DURING
CALENDAR YEARS 1976 THROUGH THE CURRENT YEAR

CLASSIFIED ACCORDING TO SERVICE AREA
(All Values in Acre Feet)

EXTRACTIONS FROM RIVERSIDE BASIN AREA WITHIN SAN BERNARDINO COUNTY FOR USE WITHIN AND EXPORT THEREFROM

PLAINTIFFS	1981			1982			1983			1984			1985		
	Total Extract	Deliveries		Total Extract	Deliveries		Total Extract	Deliveries		Total Extract	Deliveries		Total Extract	Deliveries	
		Del. in S.B. Co.	Del. in Riv. Co.		Del. in S.B. Co.	Del. in Riv. Co.		Del. in S.B. Co.	Del. in Riv. Co.		Del. in S.B. Co.	Del. in Riv. Co.			
Riverside Cement Co.*	413	413	0	0	0	0	0	0	0	0	0	0	0	0	0
City of Riverside Domestic & irrigation	2,894	1,526	1,368	3,615	2,102	1,513	2,581	1,933	648	2,891	448	2,443	3,193	714	2,479
City of Riverside Gage Canal Company	2,467	3	2,464	1,645	1	1,644	1,019	1	1,018	2,046	2	2,044	1,861	1	1,860
Inter County Water Co.	175	115	60	200	132	68	154	102	52	207	136	71	196	129	67
Jurupa Water Company	62	-	62	793	-	793	351	-	351	634	-	634	1,217	-	1,217
La Sierra Water Company	2,233	-	2,233	29	-	29	14	-	14	0	-	0	0	-	0
Riverside Highland Water Company	4,965	1,676	3,289	3,337	1,248	2,089	2,535	889	1,646	4,545	1,367	3,178	4,475	1,299	3,176
Temescal Water Company	2,196	-	2,196	1,423	-	1,423	0	-	0	1,190	-	1,190	1,817	-	1,817
West Riverside 350" Water Company	1,395	-	1,395	905	-	905	46	-	46	0	-	0	585	-	585
TOTALS	16,800	3,733	13,067	11,947	3,483	8,464	6,700	2,925	3,775	11,513	1,953	9,560	13,344	2,143	11,201

Total Extract -- TOTAL EXTRACTIONS
Del in S.B. Co. -- DELIVERY WITHIN SAN BERNARDINO COUNTY
Del. in Riv. Co. -- DELIVERY WITHIN RIVERSIDE COUNTY

TABLE NO. 52-A

GROUNDWATER PRODUCTION FROM THAT PART OF THE RIVERSIDE GROUNDWATER BASIN SITUATED
WITHIN SAN BERNARDINO COUNTY, A PART OF WHICH IS USED IN
SAN BERNARDINO COUNTY AND THE REMAINDER EXPORTED TO RIVERSIDE COUNTY DURING
CALENDAR YEARS 1976 THROUGH THE CURRENT YEAR

CLASSIFIED ACCORDING TO SERVICE AREA
(Quantities in Acre Feet)

EXTRACTIONS FROM RIVERSIDE BASIN AREA WITHIN SAN BERNARDINO COUNTY FOR USE WITHIN AND EXPORT THEREFROM

PLAINTIFFS	1986			1987			1988			1989			1990		
	Total Extract	Deliveries		Total Extract	Deliveries		Total Extract	Deliveries		Total Extract	Deliveries		Total Extract	Deliveries	
		Del. in S.B. Co.	Del. in Riv. Co.		Del. in S.B. Co.	Del. in Riv. Co.		Del. in S.B. Co.	Del. in Riv. Co.		Del. in S.B. Co.	Del. in Riv. Co.			
Riverside Cement Co.*	0	0	0	0	0	0	0	0	0	-	-	0	-	-	
City of Riverside Domestic & Irrigation	2,342	117	2,225	1,762	87	1,675	3,315	58	3,257	10,194	59	10,135	10,983	1,011	9,972
City of Riverside Gage Canal Company	1,893	2	1,891	1,996	1	1,995	2,189	2	2,187	1,965	2	1,963	1,962	1	1,961
Inter County Water Co. WSBCWD after 1988	189	125	64	78	51	27	21	0	21	21	0	21	21	0	21
Jurupa Water Company JCSD after 1988	1,372	-	1,372	1,083	-	1,083	26	-	26	248	-	248	392	-	392
La Sierra Water Company	0	0	0	0	0	0	0	0	0	0	0	0	0	0	0
Riverside Highland Water Company	2,089	1,001	1,088	1,632	578	1,054	1,785	713	1,072	2,558	1,558	1,000	2,858	1,616	1,242
Temescal Water Company	2,051	-	2,051	1,878	-	1,878	2,360	-	2,360	2,790	-	2,790	2,283	-	2,283
West Riverside 350" Water Company	0	-	0	0	-	0	0	-	0	0	-	0	0	-	0
TOTALS	9,936	1,245	8,691	8,429	717	7,712	9,696	773	8,923	17,776	1,619	16,157	18,499	2,628	15,871

Total Extract -- TOTAL EXTRACTIONS

Del in S.B. Co. -- DELIVERY WITHIN SAN BERNARDINO COUNTY

Del. in Riv. Co. -- DELIVERY WITHIN RIVERSIDE COUNTY

Bold Corrected during 1991 verification, numbers had been reversed.

2,189 "typos" found during linking of tables in 10/12

From Table No. 52, Same as Table 4, Volume 3

* Name change from American Cement (Amcord) to Riverside Cement in 1981

FOR YEARS PRECEDING 1976: Refer to Volume 5-1975, August 1976, Page 57

TABLE NO. 52-A

GROUNDWATER PRODUCTION FROM THAT PART OF THE RIVERSIDE GROUNDWATER BASIN SITUATED
WITHIN SAN BERNARDINO COUNTY, A PART OF WHICH IS USED IN
SAN BERNARDINO COUNTY AND THE REMAINDER EXPORTED TO RIVERSIDE COUNTY DURING
CALENDAR YEARS 1976 THROUGH THE CURRENT YEAR

CLASSIFIED ACCORDING TO SERVICE AREA
 (Quantities in Acre Feet)

EXTRACTIONS FROM RIVERSIDE BASIN AREA WITHIN SAN BERNARDINO COUNTY FOR USE WITHIN AND EXPORT THEREFROM

PLAINTIFFS	1991			1992			1993			1994			1995		
	Total Extract	Deliveries		Total Extract	Deliveries		Total Extract	Deliveries		Total Extract	Deliveries		Total Extract	Deliveries	
		Del. in S.B. Co.	Del. in Riv. Co.		Del. in S.B. Co.	Del. in Riv. Co.		Del. in S.B. Co.	Del. in Riv. Co.		Del. in S.B. Co.	Del. in Riv. Co.			
Riverside Cement Co.*	-	-	-	-	-	-	-	-	-	-	-	-	-	-	-
City of Riverside Domestic & Irrigation	13,203	1,005	12,198	10,343	334	10,009	9,300	69	9,231	8,203	72	8,131	10,755	0	10,755
City of Riverside Gage Canal Company	1,734	1	1,733	1,657	1	1,656	2,023	2	2,021	2,028	2	2,026	1,664	0	1,664
Inter County Water Co. WSBCWD after 1988	21	-	21	21	0	21	21	0	21	21	0	21	21	0	21
Jurupa Water Company JCSD after 1988	646	-	646	357	-	357	362	0	362	413	0	413	1,520	0	1,520
La Sierra Water Company	0	0	0	0	0	0	0	0	0	0	0	0	0	0	0
Riverside Highland Water Company	3,581	1,978	1,603	2,215	1,244	971	3,034	1,664	1,370	3,285	1,672	1,613	3,126	1,696	1,430
Temescal Water Company	2,354	-	2,354	1,714	-	1,714	1,698	0	1,698	0	0	0	556	0	556
West Riverside 350" Water Company	0	-	0	0	-	0	0	0	0	0	0	0	0	0	0
TOTALS	21,539	2,984	18,555	16,307	1,579	14,728	16,438	1,735	14,703	13,950	1,746	12,204	17,642	1,696	15,946

Total Extract -- TOTAL EXTRACTIONS
 Del in S.B. Co. -- DELIVERY WITHIN SAN BERNARDINO COUNTY
 Del. in Riv. Co. -- DELIVERY WITHIN RIVERSIDE COUNTY

From Table No. 52, Same as Table 4, Volume 3
 * Name change from American Cement (Amcord) to Riverside Cement in 1981
 FOR YEARS PRECEDING 1976: Refer to Volume 5-1975, August 1976, Page 57

TABLE NO. 52-A

GROUNDWATER PRODUCTION FROM THAT PART OF THE RIVERSIDE GROUNDWATER BASIN SITUATED
WITHIN SAN BERNARDINO COUNTY, A PART OF WHICH IS USED IN
SAN BERNARDINO COUNTY AND THE REMAINDER EXPORTED TO RIVERSIDE COUNTY DURING
CALENDAR YEARS 1976 THROUGH THE CURRENT YEAR

CLASSIFIED ACCORDING TO SERVICE AREA
(Quantities in Acre Feet)

EXTRACTIONS FROM RIVERSIDE BASIN AREA WITHIN SAN BERNARDINO COUNTY FOR USE WITHIN AND EXPORT THEREFROM

PLAINTIFFS	1996			1997			1998			1999			2000		
	Total Extract	Del. in S.B. Co.	Del. in Riv. Co.	Total Extract	Del. in S.B. Co.	Del. in Riv. Co.	Total Extract	Del. in S.B. Co.	Del. in Riv. Co.	Total Extract	Del. in S.B. Co.	Del. in Riv. Co.	Total Extract	Del. in S.B. Co.	Del. in Riv. Co.
Riverside Cement Co.*	-	-	-	-	-	-	-	-	-	-	-	-	-	-	-
City of Riverside Domestic & Irrigation	9,064	0	9,064	8,169	0	8,169	6,765	0	6,765	8,883	0	8,883	8,629	0	8,629
City of Riverside Gage Canal Company	1,706	0	1,706	1,591	0	1,591	1,823	0	1,823	2,051	0	2,051	1,664	0	1,664
Inter County Water Co. WSBCWD after 1988	21	-	21	21	-	21	21	-	21	21	-	21	21	-	21
Jurupa Water Company JCSO after 1988	1,500	-	1,500	6	6	-	6	6	-	1	1	-	1	1	-
La Sierra Water Company	0	-	0	0	-	0	0	-	0	0	-	0	0	-	0
Riverside Highland Water Company	2,396	1,308	1,088	2,513	1,352	1,161	2,195	1,324	871	2,627	1,866	761	1,138	1,120	18
Temescal Water Company	25	-	25	97	-	97	194	-	194	0	-	0	1,037	-	1,037
West Riverside 350" Water Company	0	-	0	0	-	0	0	-	0	0	-	0	0	-	0
TOTALS	14,712	1,308	13,404	12,397	1,358	11,039	11,004	1,330	9,674	13,583	1,867	11,716	12,490	1,121	11,369

Total Extract -- TOTAL EXTRACTIONS

Del in S.B. Co. -- DELIVERY WITHIN SAN BERNARDINO COUNTY

Del. in Riv. Co. -- DELIVERY WITHIN RIVERSIDE COUNTY

From Table No. 52, Same as Table 4, Volume 3

* Name change from American Cement (Acord) to Riverside Cement in 1981

FOR YEARS PRECEDING 1976: Refer to Volume 5-1975, August 1976, Page 57

TABLE NO. 52-A

GROUNDWATER PRODUCTION FROM THAT PART OF THE RIVERSIDE GROUNDWATER BASIN SITUATED
WITHIN SAN BERNARDINO COUNTY, A PART OF WHICH IS USED IN
SAN BERNARDINO COUNTY AND THE REMAINDER EXPORTED TO RIVERSIDE COUNTY DURING
CALENDAR YEARS 1976 THROUGH THE CURRENT YEAR

CLASSIFIED ACCORDING TO SERVICE AREA
(Quantities in Acre Feet)

EXTRACTIONS FROM RIVERSIDE BASIN AREA WITHIN SAN BERNARDINO COUNTY FOR USE WITHIN AND EXPORT THEREFROM

PLAINTIFFS	2001			2002			2003			2004			2005		
	Total Extract	Del. in S.B. Co.	Del. in Riv. Co.	Total Extract	Del. in S.B. Co.	Del. in Riv. Co.	Total Extract	Del. in S.B. Co.	Del. in Riv. Co.	Total Extract	Del. in S.B. Co.	Del. in Riv. Co.	Total Extract	Del. in S.B. Co.	Del. in Riv. Co.
Riverside Cement Co.*	-	-	-	-	-	-	-	-	-	-	-	-	-	-	-
City of Riverside Domestic & Irrigation	7,288	0	7,288	7,814	0	7,814	6,390	0	6,390	5,123	0	5,123	7,829	0	7,829
City of Riverside Gage Canal Company	1,491	0	1,491	1,286	0	1,286	1,339	0	1,339	1,125	0	1,125	1,354	-	1,354
Inter County Water Co. WSBCWD after 1988	21	-	21	21	-	21	21	-	21	21	-	21	21	-	21
Jurupa Water Company JCSD after 1988	1	1	-	1	1	-	1	1	-	0	-	-	34	34	-
La Sierra Water Company	0	-	0	0	-	0	0	-	0	0	-	0	0	-	0
Riverside Highland Water Company	1,341	1,280	61	2,577	2,440	137	1,885	1,698	187	2,793	2,499	294	2,031	1,836	195
Temescal Water Company	252	-	252	2,417	-	2,417	1,299	-	1,299	159	-	159	1	-	1
West Riverside 350" Water Company	0	-	0	0	-	0	0	-	0	0	-	0	0	-	0
TOTALS	10,394	1,281	9,113	14,116	2,441	11,675	10,935	1,699	9,236	9,221	2,499	6,722	11,270	1,870	9,400

Total Extract -- TOTAL EXTRACTIONS
Del in S.B. Co. -- DELIVERY WITHIN SAN BERNARDINO COUNTY
Del. in Riv. Co. -- DELIVERY WITHIN RIVERSIDE COUNTY

From Table No. 52, Same as Table 4, Volume 3
* Name change from American Cement (Accord) to Riverside Cement in 1981
FOR YEARS PRECEDING 1976: Refer to Volume 5-1975, August 1976, Page 57

TABLE NO. 52-A

GROUNDWATER PRODUCTION FROM THAT PART OF THE RIVERSIDE GROUNDWATER BASIN SITUATED
 WITHIN SAN BERNARDINO COUNTY, A PART OF WHICH IS USED IN
 SAN BERNARDINO COUNTY AND THE REMAINDER EXPORTED TO RIVERSIDE COUNTY DURING
 CALENDAR YEARS 1976 THROUGH THE CURRENT YEAR

CLASSIFIED ACCORDING TO SERVICE AREA
 (Quantities in Acre Feet)

EXTRACTIONS FROM RIVERSIDE BASIN AREA WITHIN SAN BERNARDINO COUNTY FOR USE WITHIN AND EXPORT THEREFROM

PLAINTIFFS	2006			2007			2008			2009			2010		
	Total Extract	Del. in S.B. Co.	Del. in Riv. Co.	Total Extract	Del. in S.B. Co.	Del. in Riv. Co.	Total Extract	Del. in S.B. Co.	Del. in Riv. Co.	Total Extract	Del. in S.B. Co.	Del. in Riv. Co.	Total Extract	Del. in S.B. Co.	Del. in Riv. Co.
Riverside Cement Co.*	-	-	-	-	-	-	-	-	-	-	-	-	-	-	-
City of Riverside Domestic & Irrigation	10,276	0	10,276	5,688	0	5,688	8,802	0	8,802	13,614	0	13,614	11,045	0	11,045
City of Riverside Gage Canal Company	1,969	-	1,969	1,870	-	1,870	1,849	-	1,849	1,601	-	1,601	1,074	-	1,074
West Valley Water District (was InterCounty Water Co.)	21	-	21	21	-	21	277	-	277	275	-	275	275	-	275
Agua Mansa Properties (was Jurupa Water Co)	28	28	-	25	25	-	27	27	-	29	29	-	29	29	-
La Sierra Water Company	-	-	-	-	-	-	-	-	-	-	-	-	-	-	-
Riverside Highland Water Company	1,199	1,111	88	2,136	1,900	236	1,583	1,420	163	2,617	2,325	292	2,909	2,628	281
Esinore Valley MWD (was Temescal Water Co.)	515	-	515	788	-	788	2,043	-	2,043	1,010	-	1,010	0	-	0
Empire Water Company was West Riverside 350" Water Co.	0	-	0	0	-	0	0	-	0	0	-	0	0	-	0
TOTALS	14,008	1,139	12,869	10,528	1,925	8,603	14,581	1,447	13,134	19,146	2,354	16,792	15,332	2,657	12,675

Total Extract -- TOTAL EXTRACTIONS

Del in S.B. Co. -- DELIVERY WITHIN SAN BERNARDINO COUNTY

Del. in Riv. Co. -- DELIVERY WITHIN RIVERSIDE COUNTY

West Valley reported new deliveries to Agua Mansa Business Park, corrected during 2011 Verification

From Table No. 52, Same as Table 4, Volume 3

* Name change from American Cement (Accord) to Riverside Cement in 1981

FOR YEARS PRECEDING 1976: Refer to Volume 5-1975, August 1976, Page 57

TABLE NO. 52-A

GROUNDWATER PRODUCTION FROM THAT PART OF THE RIVERSIDE GROUNDWATER BASIN SITUATED
 WITHIN SAN BERNARDINO COUNTY, A PART OF WHICH IS USED IN
 SAN BERNARDINO COUNTY AND THE REMAINDER EXPORTED TO RIVERSIDE COUNTY DURING
 CALENDAR YEARS 1976 THROUGH THE CURRENT YEAR

CLASSIFIED ACCORDING TO SERVICE AREA
 (Quantities in Acre Feet)

EXTRACTIONS FROM RIVERSIDE BASIN AREA WITHIN SAN BERNARDINO COUNTY FOR USE WITHIN AND EXPORT THEREFROM

PLAINTIFFS	2011			2012			2013			2014			2015		
	Total Extract	Del. in S.B. Co.	Del. in Riv. Co.	Total Extract	Del. in S.B. Co.	Del. in Riv. Co.	Total Extract	Del. in S.B. Co.	Del. in Riv. Co.	Total Extract	Del. in S.B. Co.	Del. in Riv. Co.	Total Extract	Del. in S.B. Co.	Del. in Riv. Co.
Riverside Cement Co.*	-	-	-	-	-	-	-	-	-	-	-	-	-	-	-
City of Riverside Domestic & Irrigation	12,043	0	12,043	13,876	0	13,876									
City of Riverside Gage Canal Company	693	-	693	1,304	-	1,304									
West Valley Water District (was InterCounty Water Co.)	275	-	275	202	-	202									
Agua Mansa Properties (was Jurupa Water Co)	28	28	-	27	27	-									
La Sierra Water Company	-	-	-	-	-	-	-	-	-	-	-	-	-	-	-
Riverside Highland Water Company	2,439	2,182	257	2,271	2,040	231									
Esinore Valley MWD (was Temescal Water Co.)	8	-	8	0	-	0									
Empire Water Company (was West Riverside 350" Water Co.)	0	-	0	0	-	0									
TOTALS	15,486	2,210	13,276	17,680	2,067	15,613									

Total Extract -- TOTAL EXTRACTIONS
 Del in S.B. Co. -- DELIVERY WITHIN SAN BERNARDINO COUNTY
 Del. in Riv. Co. -- DELIVERY WITHIN RIVERSIDE COUNTY

From Table No. 52, Same as Table 4, Volume 3
 * Name change from American Cement (Accord) to Riverside Cement in 1981

TABLE NO. 53

Page 1 of 2

SAN BERNARDINO ENTITIES PRODUCTION
FROM RIVERSIDE BASIN AREA WITHIN SAN BERNARDINO COUNTY
FOR THE PERIOD 1971 THROUGH THE CURRENT YEAR
FOR USE WITHIN SAN BERNARDINO COUNTY

(Quantities in Acre Feet)

Year	Total Verified Extractions from Riverside Basin within San Bernardino County (1)	Total Production by Riverside Entities (2)	Total Production by San Bernardino Entities (3)
Base Period Average	33,729	24,120	9,609
1971	29,070	20,322	8,748
1972	28,148	20,185	7,963
1973	21,809	15,319	6,490
1974	21,881	14,982	6,899
1975	22,701	16,188	6,513
1976	24,705	17,807	6,898
1977	23,506	16,417	7,089
1978	17,216	10,955	6,261
1979	20,024	12,962	7,062
1980	18,533	12,601	5,932
1981	23,611	16,800	6,811
1982	17,349	11,947	5,402
1983	11,904	6,700	5,204
1984	17,161	11,513	5,648
1985	19,392	13,344	6,048
1986	17,337	9,936	7,401
1987	15,803	8,429	7,374
1988	16,933	9,696	7,237
1989	25,557	17,776	7,781
1990	26,371	18,499	7,872
1991	28,011	21,539	6,472
1992	21,959 1)	16,307	5,652
1993	21,866	16,438	5,428
1994	19,661	13,950	5,711
1995	23,865 2)	17,642	6,223
1996	26,698 3)	14,712	11,986
1997	30,284 3)	12,397	17,887
1998	33,116	11,004	22,112
1999	35,482 5)	13,583	21,899
2000	36,124 5) 6)	12,490	23,634
2001	31,423 4) 5) 6)	10,394	21,029
2002	28,042 5) 6)	14,116	13,926
2003	27,648 5) 6)	10,935	16,713
2004	24,779 5) 6)	9,221	15,558
2005	29,447 5) 6)	11,270	18,177

(1) Total Extractions as verified in Volume 3, Table No. 3, for appropriate year, entitled
Summary of Verified Extractions from the Riverside Basin Area Within San Bernardino County

(2) From Table No. 52, Line 25.

(3) Column (1) - Column (2).

Same as Volume 3, Table 5.

Base Period Averages from Base Period Table 53, age 517

FOR YEARS PRECEDING 1971: Refer to Volume 5, August 1976, Page III-39.

- 1) corrected during 1994 (Owl Rock).
- 2) corrected during 1997 (Colton #24 reassigned to Riverside North, Kleckler corrected)
- 3) corrected during 1998 (RIX conversion error)
- 4) corrected during 2002 (new Cal Mat and RH wells)
- 5) corrected during 2008, Roquet backfiled 115AF for 1999-2007
- 6) corrected during 2009 verification, backfiled SBCo Hospital well 2000-2005

TABLE NO. 53

SAN BERNARDINO ENTITIES PRODUCTION
FROM RIVERSIDE BASIN AREA WITHIN SAN BERNARDINO COUNTY
FOR THE PERIOD 1971 THROUGH THE CURRENT YEAR
FOR USE WITHIN SAN BERNARDINO COUNTY

(Quantities in Acre Feet)

Year	Total Verified Extractions from Riverside Basin within San Bernardino County	Total Production by Riverside Entities	Total Production by San Bernardino Entities
	(1)	(2)	(3)
Base Period Average	33,729	24,120	9,609
2006	30,045 1)	14,008	16,037
2007	27,491 1)	10,528	16,963
2008	30,678	14,581	16,097
2009	34,180	19,146	15,034
2010	29,125	15,332	13,793
2011	29,590	15,486	14,104
2012	29,137	17,680	11,457
2013			
2014			
2015			
2016			
2017			
2018			
2019			
2020			
2021			
2022			
2023			
2024			
2025			
2026			
2027			
2028			
2029			
2030			
2031			
2032			
2033			
2034			
2035			
2036			
2037			
2038			
2039			
2040			

(1) Total Extractions as verified in Volume 3, Table No. 3, for appropriate year, entitled
 Summary of Verified Extractions from the Riverside Basin Area Within San Bernardino County

(2) From Table No. 52, Line 25.

(3) Column (1) - Column (2).

Same as Volume 3, Table 5.

Base Period Averages from Base Period Table 53, age 517

FOR YEARS PRECEDING 1971: Refer to Volume 5, August 1976, Page III-39.

1) During 2008 verification Roquet back filed 115AF for 1999-2007

TABLE NO. 54

page 1 of 9

TOTAL VERIFIED EXTRACTIONS FROM THAT PORTION
OF THE RIVERSIDE BASIN SITUATED IN SAN BERNARDINO COUNTY FOR THE
FOR THE 1959-63 BASE PERIOD AND 1971 THROUGH CURRENT YEAR
BY SAN BERNARDINO AND RIVERSIDE COUNTY ENTITIES
FOR USE WITHIN EACH COUNTY

(Quantities in Acre Feet)

Ln. #	Calendar Year	Producer	Place of Use		Total Production in A.F.
			San Bernardino County	Riverside County	
1	1959-63	San Bernardino			
	5-year	Co. Wtr. Interests	9,609	0	9,609
2	Average	Riverside Co.			
		Wtr. Interests	3,035	21,085	24,120
3		TOTAL	12,644	21,085	33,729
1	1971	San Bernardino			
		Co. Wtr. Interests	8,748	0	8,748
2		Riverside Co.			
		Wtr. Interests	2,214	18,108	20,322
3		TOTAL	10,962	18,108	29,070
1	1972	San Bernardino			
		Co. Wtr. Interests	7,963	0	7,963
2		Riverside Co.			
		Wtr. Interests	1,597	18,588	20,185
3		TOTAL	9,560	18,588	28,148
1	1973	San Bernardino			
		Co. Wtr. Interests	6,490	0	6,490
2		Riverside Co.			
		Wtr. Interests	1,333	13,986	15,319
3		TOTAL	7,823	13,986	21,809
1	1974	San Bernardino			
		Co. Wtr. Interests	6,899	0	6,899
2		Riverside Co.			
		Wtr. Interests	1,399	13,583	14,982
3		TOTAL	8,298	13,583	21,881
1	1975	San Bernardino			
		Co. Wtr. Interests	6,513	0	6,513
2		Riverside Co.			
		Wtr. Interests	1,225	14,963	16,188
3		TOTAL	7,738	14,963	22,701

line 1: Table 53, Column (3)

line 2: Table 52A, Column (2),(3),(1)

Base Period Averages from Base Period Volume 5, Table 54

TABLE NO. 54

page 2 of 9

TOTAL VERIFIED EXTRACTIONS FROM THAT PORTION
OF THE RIVERSIDE BASIN SITUATED IN SAN BERNARDINO COUNTY FOR THE
PERIOD 1971 THROUGH CURRENT YEAR
BY SAN BERNARDINO AND RIVERSIDE COUNTY ENTITIES
FOR USE WITHIN EACH COUNTY

(Quantities in Acre Feet)

Calendar Year	Producer	Place of Use		Total Production in A.F.
		San Bernardino County	Riverside County	
1976	San Bernardino			
	Co. Wtr. Interests	6,898	0	6,898
	Riverside Co.			
	Wtr. Interests	1,666	16,141	17,807
	TOTAL	8,564	16,141	24,705
1977	San Bernardino			
	Co. Wtr. Interests	7,089	0	7,089
	Riverside Co.			
	Wtr. Interests	1,985	14,432	16,417
	TOTAL	9,074	14,432	23,506
1978	San Bernardino			
	Co. Wtr. Interests	6,261	0	6,261
	Riverside Co.			
	Wtr. Interests	1,900	9,055	10,955
	TOTAL	8,161	9,055	17,216
1979	San Bernardino			
	Co. Wtr. Interests	7,062	0	7,062
	Riverside Co.			
	Wtr. Interests	2,370	10,592	12,962
	TOTAL	9,432	10,592	20,024
1980	San Bernardino			
	Co. Wtr. Interests	5,932	0	5,932
	Riverside Co.			
	Wtr. Interests	3,410	9,191	12,601
	TOTAL	9,342	9,191	18,533

line 1: Table 53, Column (3)

line 2: Table 52A, Column (2),(3),(1)

TABLE NO. 54

page 3 of 9

TOTAL VERIFIED EXTRACTIONS FROM THAT PORTION
OF THE RIVERSIDE BASIN SITUATED IN SAN BERNARDINO COUNTY FOR THE
PERIOD 1971 THROUGH CURRENT YEAR
BY SAN BERNARDINO AND RIVERSIDE COUNTY ENTITIES
FOR USE WITHIN EACH COUNTY

(Quantities in Acre Feet)

Ln. #	Calendar Year	Producer	Place of Use		Total Production in A.F.
			San Bernardino County	Riverside County	
1	1981	San Bernardino Co. Wtr. Interests	6,811	0	6,811
2		Riverside Co. Wtr. Interests	3,733	13,067	16,800
3		TOTAL	10,544	13,067	23,611
1	1982	San Bernardino Co. Wtr. Interests	5,402	0	5,402
2		Riverside Co. Wtr. Interests	3,483	8,464	11,947
3		TOTAL	8,885	8,464	17,349
1	1983	San Bernardino Co. Wtr. Interests	5,204	0	5,204
2		Riverside Co. Wtr. Interests	2,925	3,775	6,700
3		TOTAL	8,129	3,775	11,904
1	1984	San Bernardino Co. Wtr. Interests	5,648	0	5,648
2		Riverside Co. Wtr. Interests	1,953	9,560	11,513
3		TOTAL	7,601	9,560	17,161
1	1985	San Bernardino Co. Wtr. Interests	6,048	0	6,048
2		Riverside Co. Wtr. Interests	2,143	11,201	13,344
3		TOTAL	8,191	11,201	19,392

line 1: Table 53, Column (3)

line 2: Table 52A, Column (2),(3),(1)

TABLE NO. 54

page 4 of 9

TOTAL VERIFIED EXTRACTIONS FROM THAT PORTION
OF THE RIVERSIDE BASIN SITUATED IN SAN BERNARDINO COUNTY FOR THE
PERIOD 1971 THROUGH CURRENT YEAR
BY SAN BERNARDINO AND RIVERSIDE COUNTY ENTITIES
FOR USE WITHIN EACH COUNTY

(Quantities in Acre Feet)

Ln. #	Calendar Year	Producer	Place of Use		Total Production in A.F.
			San Bernardino County	Riverside County	
1	1986	San Bernardino Co. Wtr. Interests	7,401	0	7,401
2		Riverside Co. Wtr. Interests	1,245	8,691	9,936
3		TOTAL	8,646	8,691	17,337
1	1987	San Bernardino Co. Wtr. Interests	7,374	0	7,374
2		Riverside Co. Wtr. Interests	717	7,712	8,429
3		TOTAL	8,091	7,712	15,803
1	1988	San Bernardino Co. Wtr. Interests	7,237	0	7,237
2		Riverside Co. Wtr. Interests	773	8,923	9,696
3		TOTAL	8,010	8,923	16,933
1	1989	San Bernardino Co. Wtr. Interests	7,781	0	7,781
2		Riverside Co. Wtr. Interests	1,619	16,157	17,776
3		TOTAL	9,400	16,157	25,557
1	1990	San Bernardino Co. Wtr. Interests	7,872	0	7,872
2		Riverside Co. Wtr. Interests	2,628	15,871	18,499
3		TOTAL	10,500	15,871	26,371

line 1: Table 53, Column (3)

line 2: Table 52A, Column (2),(3),(1)

TABLE NO. 54

page 5 of 9

TOTAL VERIFIED EXTRACTIONS FROM THAT PORTION
OF THE RIVERSIDE BASIN SITUATED IN SAN BERNARDINO COUNTY FOR THE
PERIOD 1971 THROUGH CURRENT YEAR
BY SAN BERNARDINO AND RIVERSIDE COUNTY ENTITIES
FOR USE WITHIN EACH COUNTY

(Quantities in Acre Feet)

Ln. #	Calendar Year	Producer	Place of Use		Total Production in A.F.
			San Bernardino County	Riverside County	
1	1991	San Bernardino Co. Wtr. Interests	6,472	0	6,472
2		Riverside Co. Wtr. Interests	2,984	18,555	21,539
3		TOTAL	9,456	18,555	28,011
1	1992	San Bernardino Co. Wtr. Interests	5,652	0	5,652
2		Riverside Co. Wtr. Interests	1,579	14,728	16,307
3		TOTAL	7,231	14,728	21,959
1	1993	San Bernardino Co. Wtr. Interests	5,428	0	5,428
2		Riverside Co. Wtr. Interests	1,735	14,703	16,438
3		TOTAL	7,163	14,703	21,866
1	1994	San Bernardino Co. Wtr. Interests	5,711	0	5,711
2		Riverside Co. Wtr. Interests	1,746	12,204	13,950
3		TOTAL	7,457	12,204	19,661
1	1995	San Bernardino Co. Wtr. Interests	6,223	0	6,223
2		Riverside Co. Wtr. Interests	1,696	15,946	17,642
3		TOTAL	7,919	15,946	23,865

line 1: Table 53, Column (3)

line 2: Table 52A, Column (2),(3),(1)

TABLE NO. 54

TOTAL VERIFIED EXTRACTIONS FROM THAT PORTION
OF THE RIVERSIDE BASIN SITUATED IN SAN BERNARDINO COUNTY FOR THE
PERIOD 1971 THROUGH CURRENT YEAR
BY SAN BERNARDINO AND RIVERSIDE COUNTY ENTITIES
FOR USE WITHIN EACH COUNTY

(Quantities in Acre Feet)

Ln. #	Calendar Year	Producer	Place of Use		Total Production in A.F.
			San Bernardino County	Riverside County	
1	1996	San Bernardino Co. Wtr. Interests	11,986	0	11,986
2		Riverside Co. Wtr. Interests	1,308	13,404	14,712
3		TOTAL	13,294	13,404	26,698
1	1997	San Bernardino Co. Wtr. Interests	17,887	0	17,887
2		Riverside Co. Wtr. Interests	1,358	11,039	12,397
3		TOTAL	19,245	11,039	30,284
1	1998	San Bernardino Co. Wtr. Interests	22,112	0	22,112
2		Riverside Co. Wtr. Interests	1,330	9,674	11,004
3		TOTAL	23,442	9,674	33,116
1	1990	San Bernardino Co. Wtr. Interests	21,899	0	21,899
2		Riverside Co. Wtr. Interests	1,867	11,716	13,583
3		TOTAL	23,766	11,716	35,482
1	2000	San Bernardino Co. Wtr. Interests	23,634	0	23,634
2		Riverside Co. Wtr. Interests	1,121	11,369	12,490
3		TOTAL	24,755	11,369	36,124

line 1: Table 53, Column (3)

line 2: Table 52A, Column (2),(3),(1)

TABLE NO. 54

TOTAL VERIFIED EXTRACTIONS FROM THAT PORTION
OF THE RIVERSIDE BASIN SITUATED IN SAN BERNARDINO COUNTY FOR THE
PERIOD 1971 THROUGH CURRENT YEAR
BY SAN BERNARDINO AND RIVERSIDE COUNTY ENTITIES
FOR USE WITHIN EACH COUNTY

(Quantities in Acre Feet)

Ln. #	Calendar Year	Producer	Place of Use		Total Production in A.F.
			San Bernardino County	Riverside County	
1	2001	San Bernardino Co. Wtr. Interests	21,029	0	21,029
2		Riverside Co. Wtr. Interests	1,281	9,113	10,394
3		TOTAL	22,310	9,113	31,423 1)
1	2002	San Bernardino Co. Wtr. Interests	13,926	0	13,926
2		Riverside Co. Wtr. Interests	2,441	11,675	14,116
3		TOTAL	16,367	11,675	28,042 1)
1	2003	San Bernardino Co. Wtr. Interests	16,713	0	16,713
2		Riverside Co. Wtr. Interests	1,699	9,236	10,935
3		TOTAL	18,412	9,236	27,648 1)
1	2004	San Bernardino Co. Wtr. Interests	15,558	0	15,558
2		Riverside Co. Wtr. Interests	2,499	6,722	9,221
3		TOTAL	18,057	6,722	24,779 1)
1	2005	San Bernardino Co. Wtr. Interests	18,177	0	18,177
2		Riverside Co. Wtr. Interests	1,870	9,400	11,270
3		TOTAL	20,047	9,400	29,447 1)

line 1: Table 53, Column (3)

line 2: Table 52A, Column (2),(3),(1)

1) corrected during 2008 &2009 verifiecation, Roquet and SBCo Hospital

TOTAL VERIFIED EXTRACTIONS FROM THAT PORTION
OF THE RIVERSIDE BASIN SITUATED IN SAN BERNARDINO COUNTY FOR THE
PERIOD 1971 THROUGH CURRENT YEAR
BY SAN BERNARDINO AND RIVERSIDE COUNTY ENTITIES
FOR USE WITHIN EACH COUNTY

(Quantities in Acre Feet)

Ln. #	Calendar Year	Producer	Place of Use		Total Production in A.F.
			San Bernardino County	Riverside County	
1	2006	San Bernardino Co. Wtr. Interests	16,037	0	16,037
2		Riverside Co. Wtr. Interests	1,139	12,869	14,008
3		TOTAL	17,176	12,869	30,045 ¹⁾
1	2007	San Bernardino Co. Wtr. Interests	16,963	0	16,963
2		Riverside Co. Wtr. Interests	1,925	8,603	10,528
3		TOTAL	18,888	8,603	27,491 ¹⁾
1	2008	San Bernardino Co. Wtr. Interests	16,097	0	16,097
2		Riverside Co. Wtr. Interests	1,447	13,134	14,581
3		TOTAL	17,544	13,134	30,678
1	2009	San Bernardino Co. Wtr. Interests	15,034	0	15,034
2		Riverside Co. Wtr. Interests	2,354	16,792	19,146
3		TOTAL	17,388	16,792	34,180
1	2010	San Bernardino Co. Wtr. Interests	13,793	0	13,793
2		Riverside Co. Wtr. Interests	2,657	12,675	15,332
3		TOTAL	16,450	12,675	29,125

line 1: Table 53, Column (3)

line 2: Table 52A, Column (2),(3),(1)

1) corrected during 2008 & 2009 verification, Roquet and SBCo Hospital

TABLE NO. 54

page 9 of 9

TOTAL VERIFIED EXTRACTIONS FROM THAT PORTION
OF THE RIVERSIDE BASIN SITUATED IN SAN BERNARDINO COUNTY FOR THE
PERIOD 1971 THROUGH CURRENT YEAR
BY SAN BERNARDINO AND RIVERSIDE COUNTY ENTITIES
FOR USE WITHIN EACH COUNTY

(Quantities in Acre Feet)

Ln. #	Calendar Year	Producer	Place of Use		Total Production in A.F.
			San Bernardino County	Riverside County	
1	2011	San Bernardino Co. Wtr. Interests	14,104	0	14,104
2		Riverside Co. Wtr. Interests	2,210	13,276	15,486
3		TOTAL	16,314	13,276	29,590
1	2012	San Bernardino Co. Wtr. Interests	11,454	0	11,454
2		Riverside Co. Wtr. Interests	2,067	15,613	17,680
3		TOTAL	13,521	15,613	29,134
1	2013	San Bernardino Co. Wtr. Interests			
2		Riverside Co. Wtr. Interests			
3		TOTAL			
1	2014	San Bernardino Co. Wtr. Interests			
2		Riverside Co. Wtr. Interests			
3		TOTAL			
1	2015	San Bernardino Co. Wtr. Interests			
2		Riverside Co. Wtr. Interests			
3		TOTAL			

line 1: Table 53, Column (3)

line 2: Table 52A, Column (2),(3),(1)

Volume 5

Tables 55-56

Riverside South Basin
production by Riverside
County Entities

The following Table is not needed
after the Base Period Verification Work

**Water Production in
Riverside South Basin**

Table Numbered 55

see Volume 5-1974 for data

TABLE NO. 56

Page 1 of 2

TOTAL VERIFIED EXTRACTIONS BY RIVERSIDE ENTITIES
FROM THE RIVERSIDE BASIN ARE WITHIN RIVERSIDE COUNTY
FOR USE WITHIN RIVERSIDE COUNTY

(Quantities in Acre Feet)

Year	Extractions	Accumulated Extractions
Base Period Average	29,634	
1971	30,942	30,942
1972	37,804	68,746
1973	33,094	101,840
1974	38,304	140,144
1975	28,285	168,429
1976	31,565	199,994
1977	28,226	228,220
1978	24,576	252,796
1979	25,512	278,308
1980	30,206	308,514
1981	30,243	338,757
1982	20,365	359,122
1983	22,991	382,113
1984	32,466	414,579
1985	23,970	438,549
1986	24,549	463,098
1987	24,202	487,300
1988	24,470 ^{1) 3)}	511,770
1989	34,417 ^{2) 3)}	546,187
1990	31,760 ³⁾	577,947
1991	29,364 ⁴⁾	607,311
1992	26,538 ⁴⁾	633,849
1993	26,505	660,354
1994	28,125	688,479
1995	22,580	711,059
1996	24,906	735,965
1997	29,128	765,093
1998	28,558	793,651
1999	33,837 ⁶⁾	827,488
2000	32,263 ⁶⁾	859,751
2001	33,656 ⁶⁾	893,407
2002	31,013 ⁶⁾	924,420
2003	30,957 ⁶⁾	955,377
2004	35,530 ⁶⁾	990,907
2005	32,737 ^{5) 6)}	1,023,644

Same Table No.4, Volume 4. Data from Volume 4, Table 3.

The verified extraction for the five-year base period ending in 1963 are 29,634 acre feet annually, as compared with 30,044 acre feet annually assumed in the Judgement. From Base Period Report, Volume 5, Table 56, page 530

- 1) Corrected during 1989 verification (Michael C.).
- 2) Corrected during 1990 verification (Riv. Cement 60-1, C of R Garner T&G, 1st St).
- 3) Corrected during 1991 verification (Riv.Co Pk Edmund, wrong meter # for 5 yrs).
- 4) Corrected during 1993 verification (Riv Cement 88-1).
- 5) Corrected during 2006 verification (JCSD #21).
- 6) 1999-2005 corrected for Hunter Engineering well - 45 af/yr

TABLE NO. 56

TOTAL VERIFIED EXTRactions BY RIVERSIDE ENTITIES
FROM THE RIVERSIDE BASIN ARE WITHIN RIVERSIDE COUNTY
FOR USE WITHIN RIVERSIDE COUNTY

(Quantities in Acre Feet)

Year	Extractions	Accumulated Extractions
Base Period Average	29,634	
2006	31,026	1,054,670
2007	38,237	1,092,907
2008	31,205	1,124,112
2009	35,519	1,159,631
2010	29,077	1,188,708
2011	30,510	1,219,218
2012	28,049	1,247,267
2013		
2014		
2015		
2016		
2017		
2018		
2019		
2020		
2021		
2022		
2023		
2024		
2025		
2026		
2027		
2028		
2029		
2030		
2031		
2032		
2033		
2034		
2035		
2036		
2037		
2038		
2039		
2040		

Same Table No.4, Volume 4. Data from Volume 4, Table 3.
 The verified extraction for the five-year base period ending in 1963 are 29,634 acre feet annually, as compared with 30,044 acre feet annually assumed in the Judgement.
 From Base Period Report, Volume 5, Table 56, page 530
 1) Starting with 2008, this value is production less RPU blowoff

Volume 5

Tables 57

Summary of extraction for use
in Riverside County from
SBBA, Colton, Riverside North
and Riverside South

TABLE NO. 57

SUMMARY OF EXTRACTIONS FROM SAN BERNARDINO
BASIN AREA, COLTON BASIN AREA, RIVERSIDE BASIN AREA
IN SAN BERNARDINO COUNTY, AND RIVERSIDE BASIN AREA
IN RIVERSIDE COUNTY FOR USE IN RIVERSIDE COUNTY
(Quantities in Acre Feet)

Basin Extractions for Use in Riverside County

Calendar Year	San Bernardino Basin Area From Table 36-E	Colton Basin Area From Table 38	Riverside North Basin From Table 52-A	RiversideSouth Basin From Table 56	Total
Base Period	59,438	3,381	21,085	29,634	113,538
Right/ Average					
1971	57,477	2,777	18,108	30,942	109,304
1972	50,744	2,611	18,588	37,804	109,747
1973	47,083	615	13,986	33,094	94,778
1974	49,445	1,464	13,583	38,304	102,796
1975	54,056	3,873	14,963	28,285	101,177
1976	58,776	2,688	16,141	31,565	109,170
1977	56,577	2,269	14,432	28,226	101,504
1978	47,012	895	9,055	24,576	81,538
1979	57,397	1,682	10,592	25,512	95,183
1980	54,007	76	9,191	30,206	93,480
1981	55,763	173	13,067	30,243	99,246
1982	54,052	981	8,464	20,365	83,862
1983	48,978	95	3,775	22,991	75,839
1984	65,894	1,341	9,560	32,466	109,261
1985	69,523	2,243	11,201	23,970	106,937
1986	67,540	1,578	8,691	24,549	102,358
1987	64,113	1,556	7,712	24,202	97,583
1988	71,155	1,707	8,923	24,470	106,255 ¹⁾
1989	58,683	2,005	16,157	34,417	111,262 ²⁾
1990	53,260	1,652	15,871	31,760	102,543 ³⁾
1991	58,365	1,835	18,555	29,364	108,119 ⁴⁾
1992	55,827	1,455	14,728	26,538	98,548 ⁴⁾
1993	58,959	396	14,703	26,505	100,563
1994	67,415	1,066	12,204	28,125	108,810
1995	61,105	489	15,946	22,580	100,120
1996	69,561	577	13,404	24,906	108,449
1997	66,259	1,141	11,039	29,128	107,568
1998	59,915	251	9,674	28,558	98,397
1999	68,595	912 ⁵⁾	11,716	33,837	115,060
2000	67,503	213	11,369	32,263	111,348
2001	63,301	165	9,113	33,656	106,235
2002	71,634	1,279	11,675	31,013	115,601
2003	64,277	1,062	9,236	30,957	105,531
2004	58,246	172	6,722	35,530	100,669
2005	52,951	84	9,400	32,737 ⁶⁾	95,172

FOR YEARS PRECEDING 1971: Refer to Volume 5, August 1976, Page IV-11.

- 1) Corrected during 1989 Verification.
- 2) Corrected during 1990 Verification.
- 3) Corrected during 1991 Verification.

- 4) Corrected during 1993 Verification.
- 5) Corrected during 2000 Verification.
- 6) Corrected during 2006 Verification.

TABLE NO. 57

SUMMARY OF EXTRACTIONS FROM SAN BERNARDINO
 BASIN AREA, COLTON BASIN AREA, RIVERSIDE BASIN AREA
 IN SAN BERNARDINO COUNTY, AND RIVERSIDE BASIN AREA
 IN RIVERSIDE COUNTY FOR USE IN RIVERSIDE COUNTY
 (Quantities in Acre Feet)

Basin Extractions for Use in Riverside County

Calendar Year	San Bernardino Basin Area From Table 36-E	Colton Basin Area From Table 38	Riverside North Basin From Table 52-A	RiversideSouth Basin From Table 56	Total
Base Period	59,438	3,381	21,085	29,634	113,538
Right/ Average					
2006	59,310	412 1)	12,869	31,026	103,617
2007	61,967	742 1)	8,603	38,237	109,549
2008	59,555	939 1)	13,134	31,205	104,832
2009	50,396	378 1)	16,792	35,519	103,085
2010	53,414	77	12,675	29,077	95,243
2011	54,647	173	13,276	30,510	98,607
2012	60,758	74	15,613	28,049	104,494
2013					
2014					
2015					
2016					
2017					
2018					
2019					
2020					
2021					
2022					
2023					
2024					
2025					
2026					
2027					
2028					
2029					
2030					
2031					
2032					
2033					
2034					
2035					
2036					
2037					
2038					
2039					
2040					

FOR YEARS PRECEDING 1971: Refer to Volume 5, August 1976, Page IV-11.

1) corrected during 2011 verification, lost M&D production link

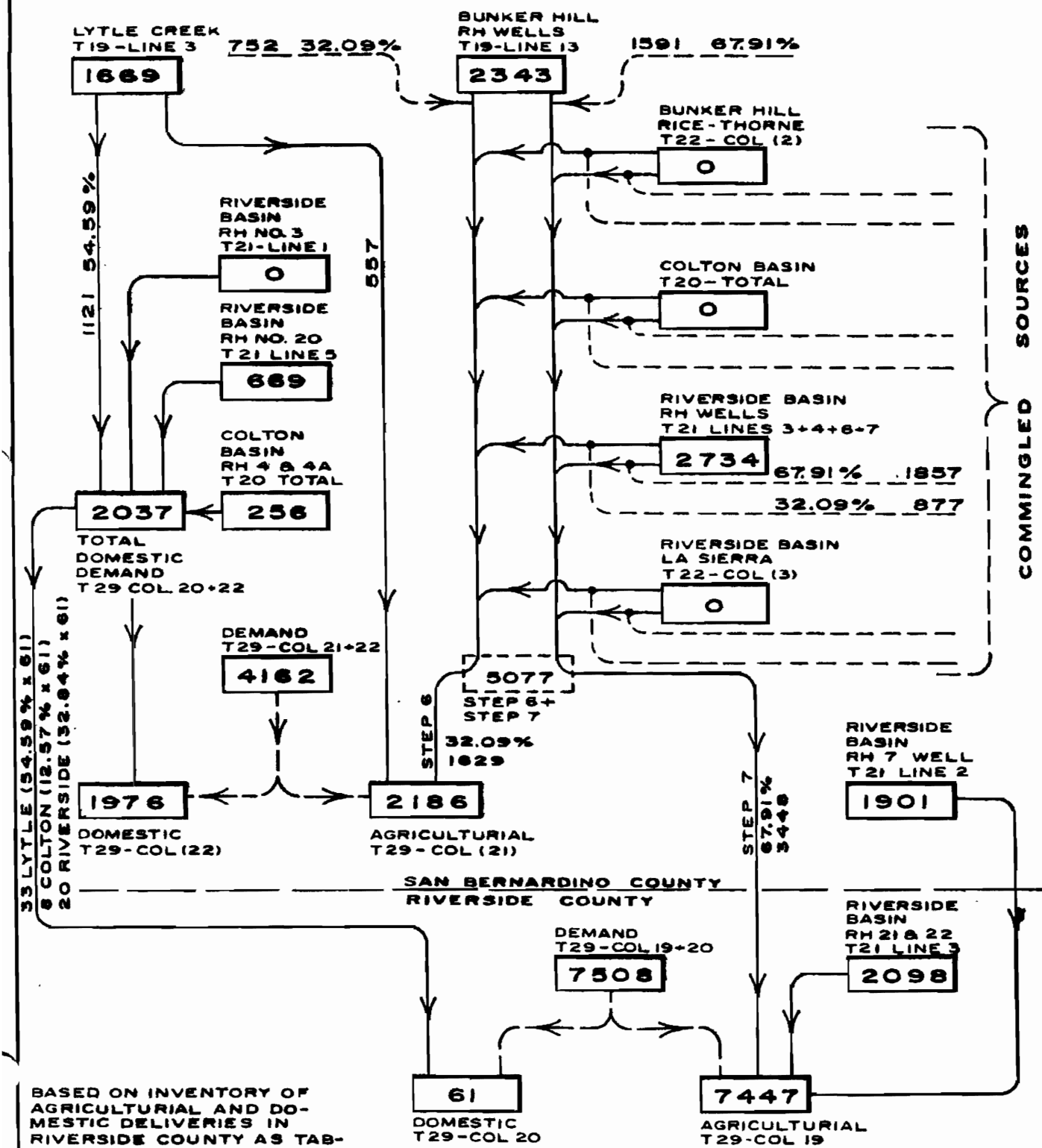
Volume 5

Diagram B

**Riverside Highland Water
Company water production and
distribution flow charts**

DIAGRAM B
RIVERSIDE HIGHLAND WATER COMPANY
DIAGRAM ILLUSTRATING THE PRODUCTION AND DISTRIBUTION
NORTH AND SOUTH OF RIVERSIDE-SAN BERNARDINO CO. LINE

YEAR 1971

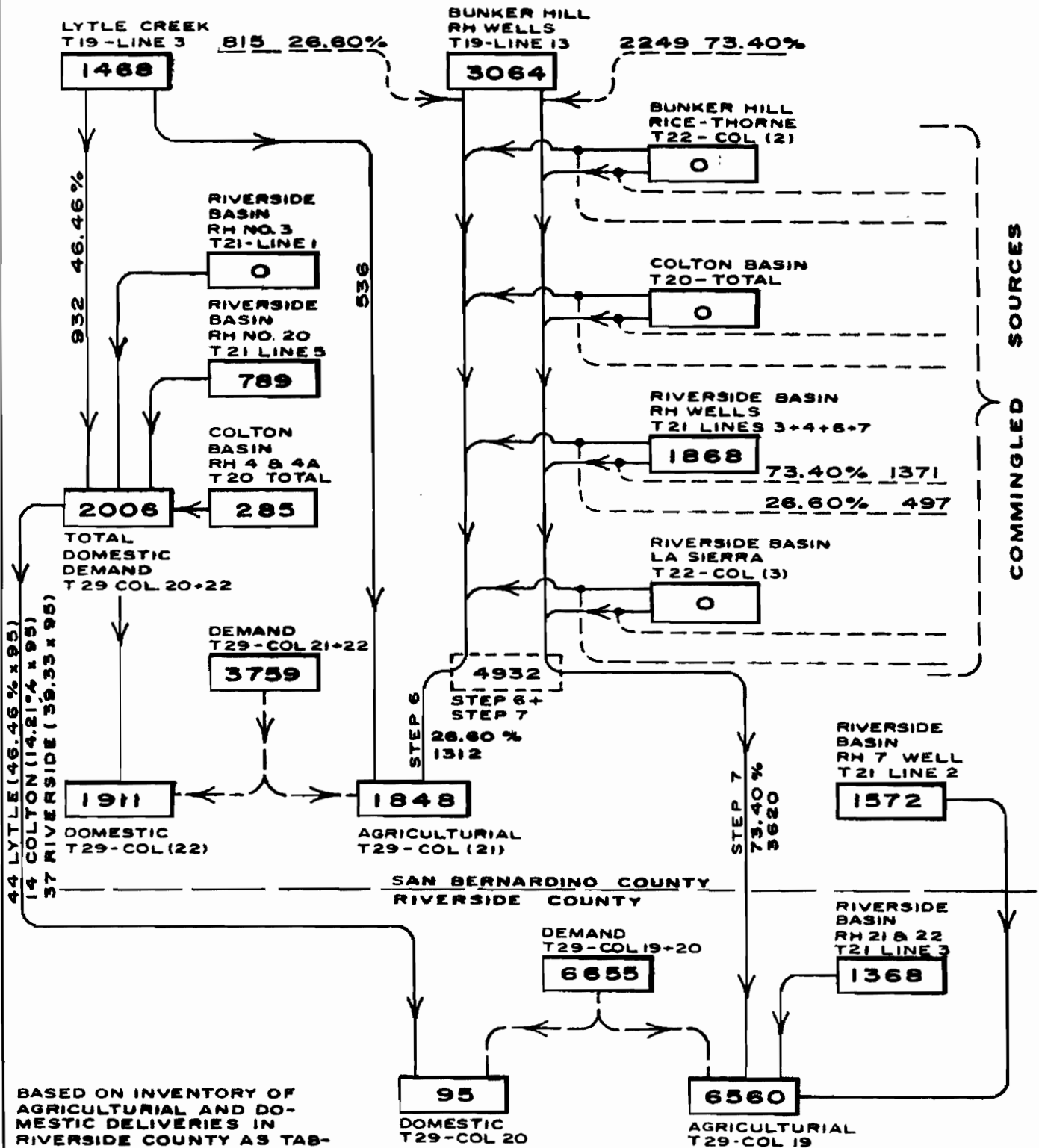


BASED ON INVENTORY OF AGRICULTURAL AND DOMESTIC DELIVERIES IN RIVERSIDE COUNTY AS TABULATED ON TABLE NOS. 30 AND 31.

DIAGRAM B

RIVERSIDE HIGHLAND WATER COMPANY
 DIAGRAM ILLUSTRATING THE PRODUCTION AND DISTRIBUTION
 NORTH AND SOUTH OF RIVERSIDE-SAN BERNARDINO CO. LINE

YEAR 1972

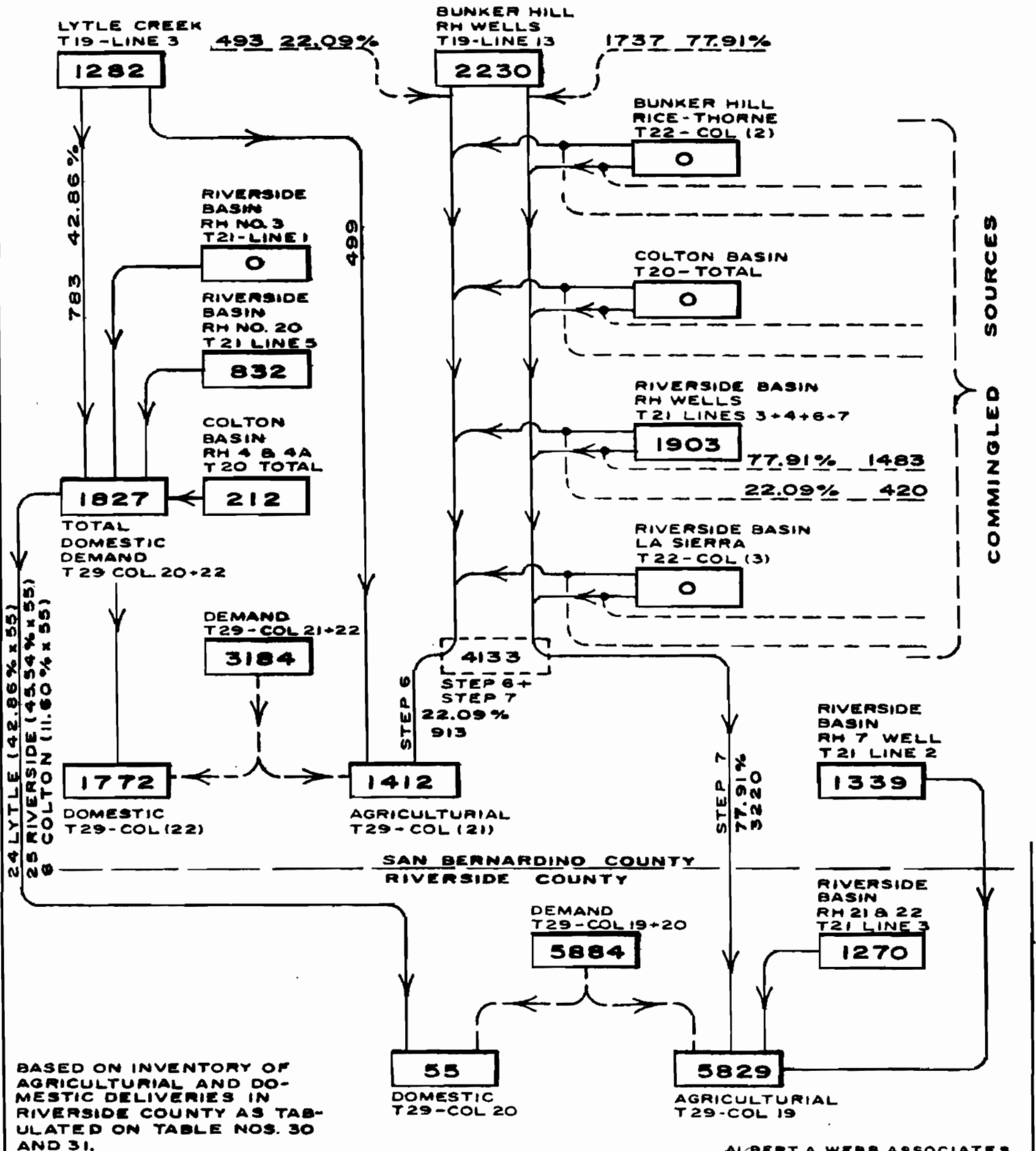


BASED ON INVENTORY OF AGRICULTURAL AND DOMESTIC DELIVERIES IN RIVERSIDE COUNTY AS TABULATED ON TABLE NOS. 30 AND 31.

DIAGRAM B

RIVERSIDE HIGHLAND WATER COMPANY
 DIAGRAM ILLUSTRATING THE PRODUCTION AND DISTRIBUTION
 NORTH AND SOUTH OF RIVERSIDE-SAN BERNARDINO CO. LINE

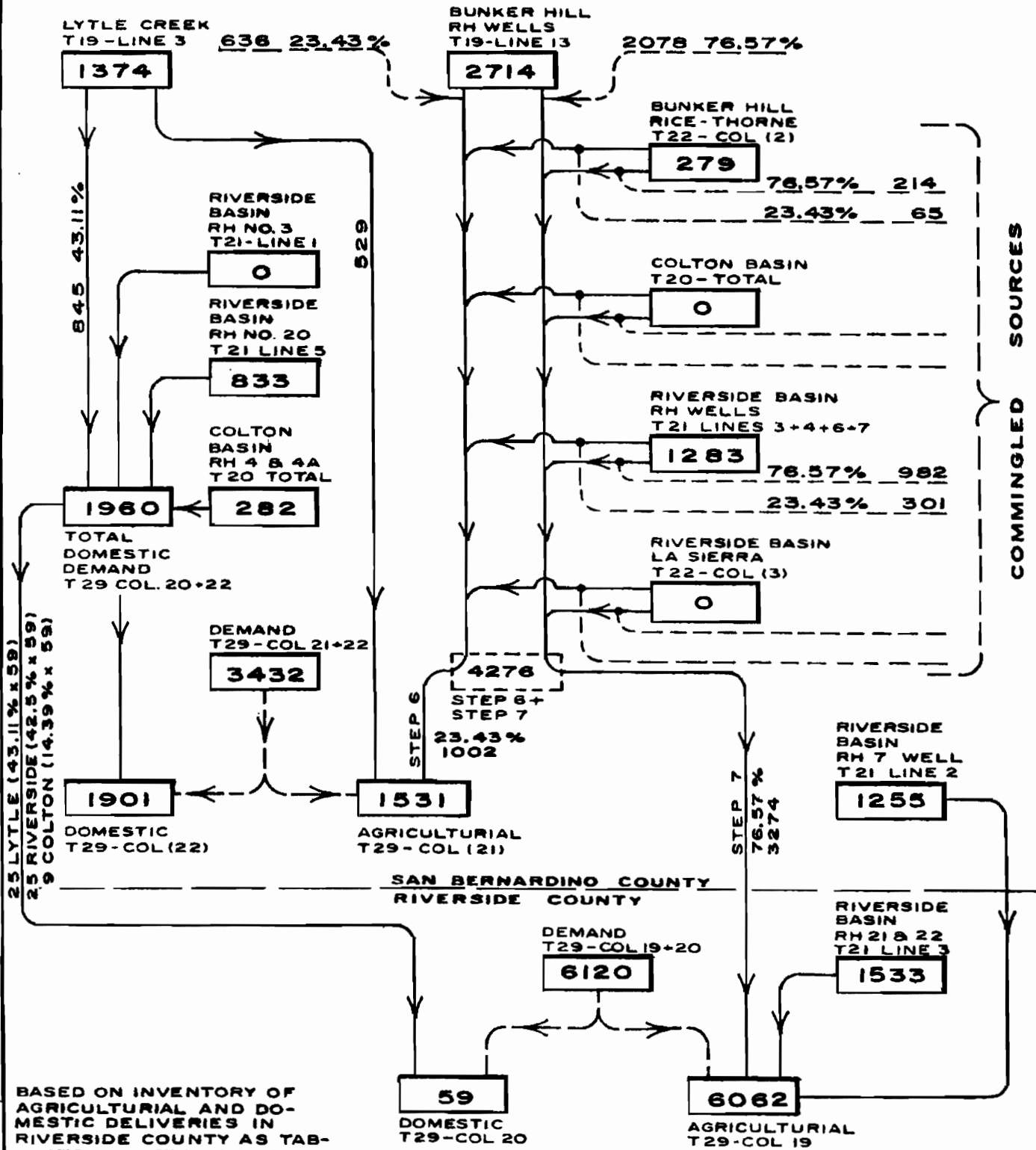
YEAR 1973



BASED ON INVENTORY OF AGRICULTURAL AND DOMESTIC DELIVERIES IN RIVERSIDE COUNTY AS TABULATED ON TABLE NOS. 30 AND 31.

DIAGRAM B
RIVERSIDE HIGHLAND WATER COMPANY
 DIAGRAM ILLUSTRATING THE PRODUCTION AND DISTRIBUTION
 NORTH AND SOUTH OF RIVERSIDE-SAN BERNARDINO CO. LINE

YEAR 1974

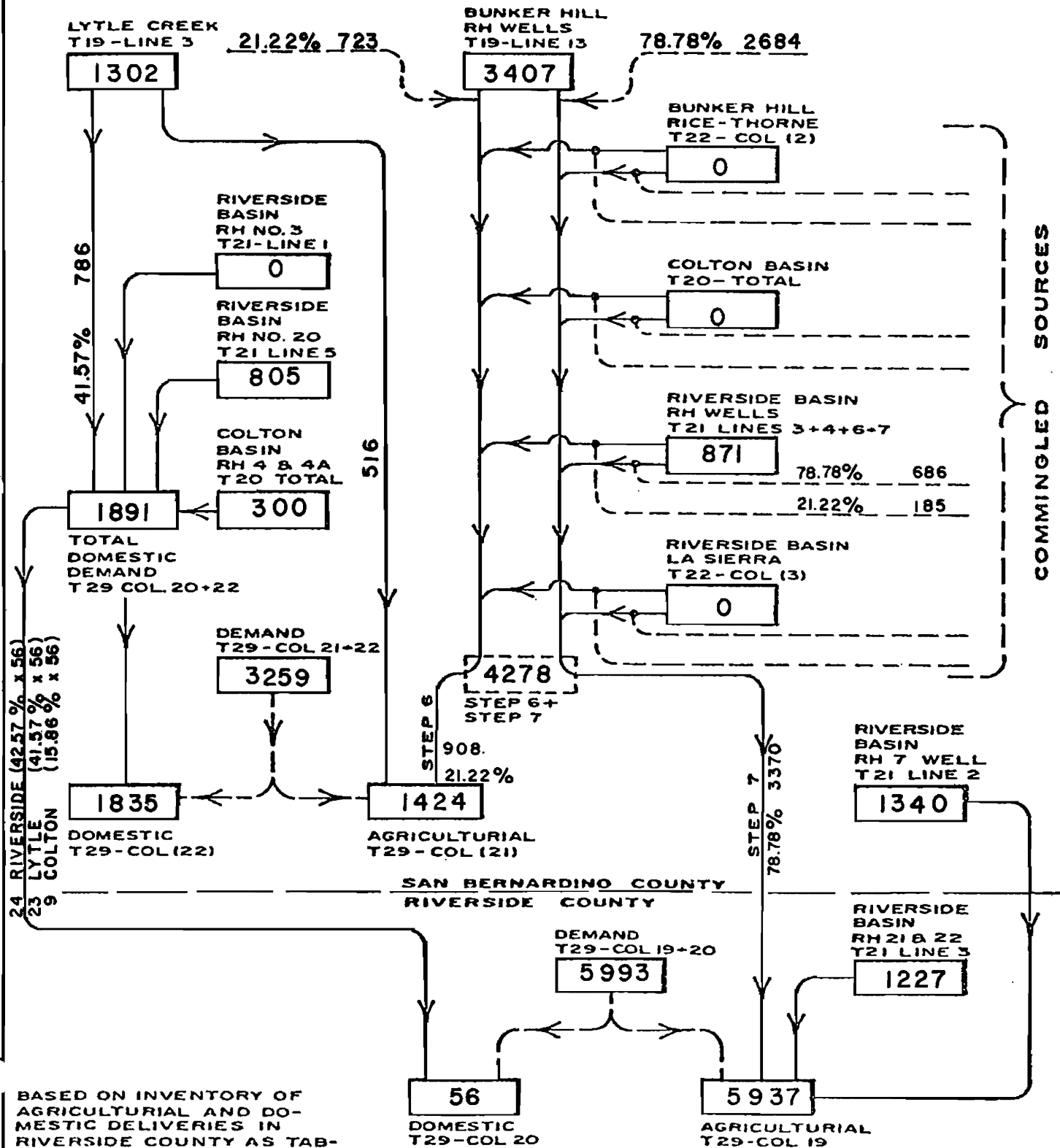


BASED ON INVENTORY OF AGRICULTURAL AND DOMESTIC DELIVERIES IN RIVERSIDE COUNTY AS TABULATED ON TABLE NOS. 30 AND 31.

DIAGRAM B

RIVERSIDE HIGHLAND WATER COMPANY
 DIAGRAM ILLUSTRATING THE PRODUCTION AND DISTRIBUTION
 NORTH AND SOUTH OF RIVERSIDE-SAN BERNARDINO CO. LINE

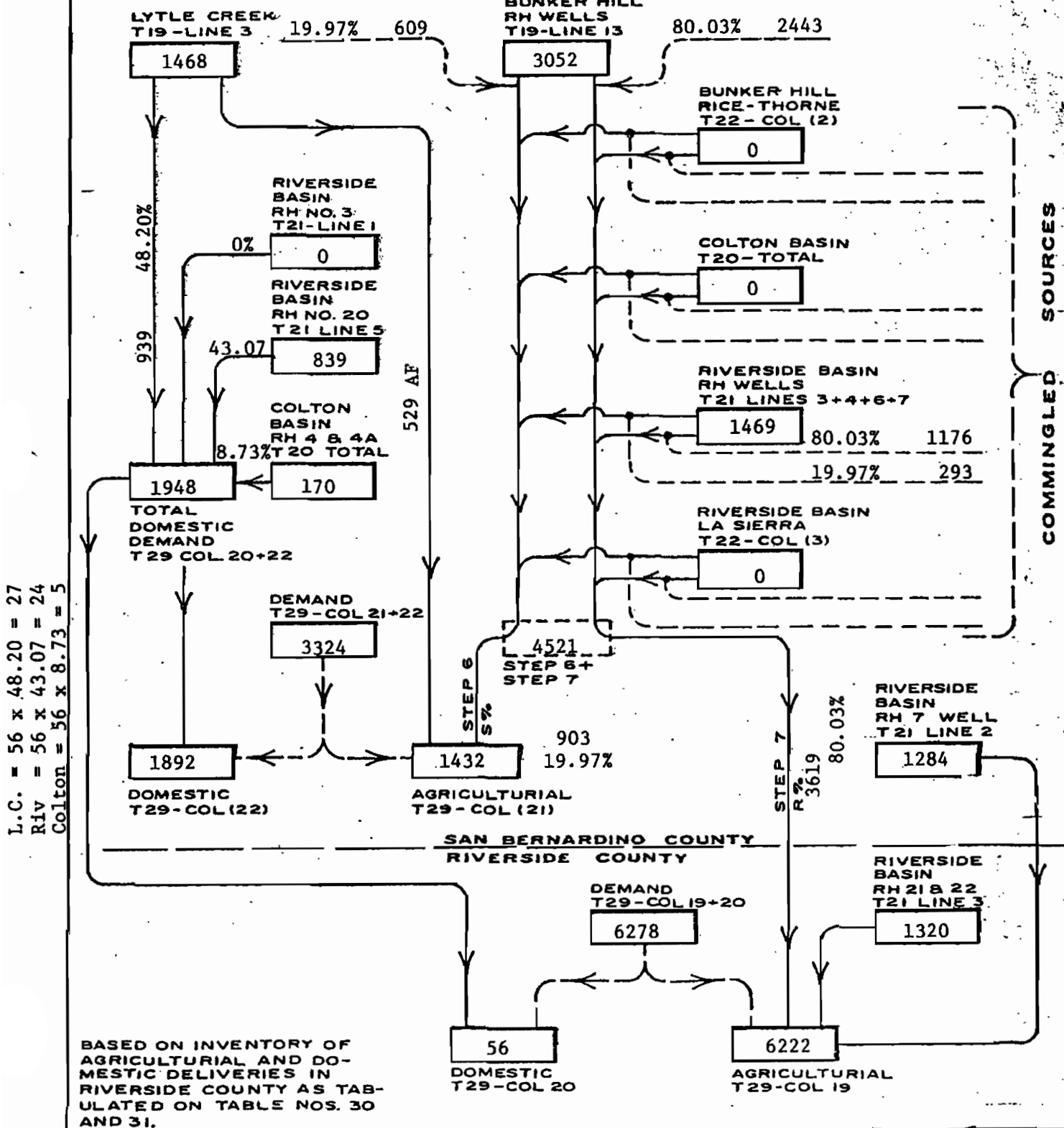
YEAR 1975



BASED ON INVENTORY OF AGRICULTURAL AND DOMESTIC DELIVERIES IN RIVERSIDE COUNTY AS TABULATED ON TABLE NOS. 30 AND 31.

**RIVERSIDE HIGHLAND WATER COMPANY
DIAGRAM ILLUSTRATING THE PRODUCTION AND DISTRIBUTION
NORTH AND SOUTH OF RIVERSIDE-SAN BERNARDINO CO. LINE**

YEAR 1976

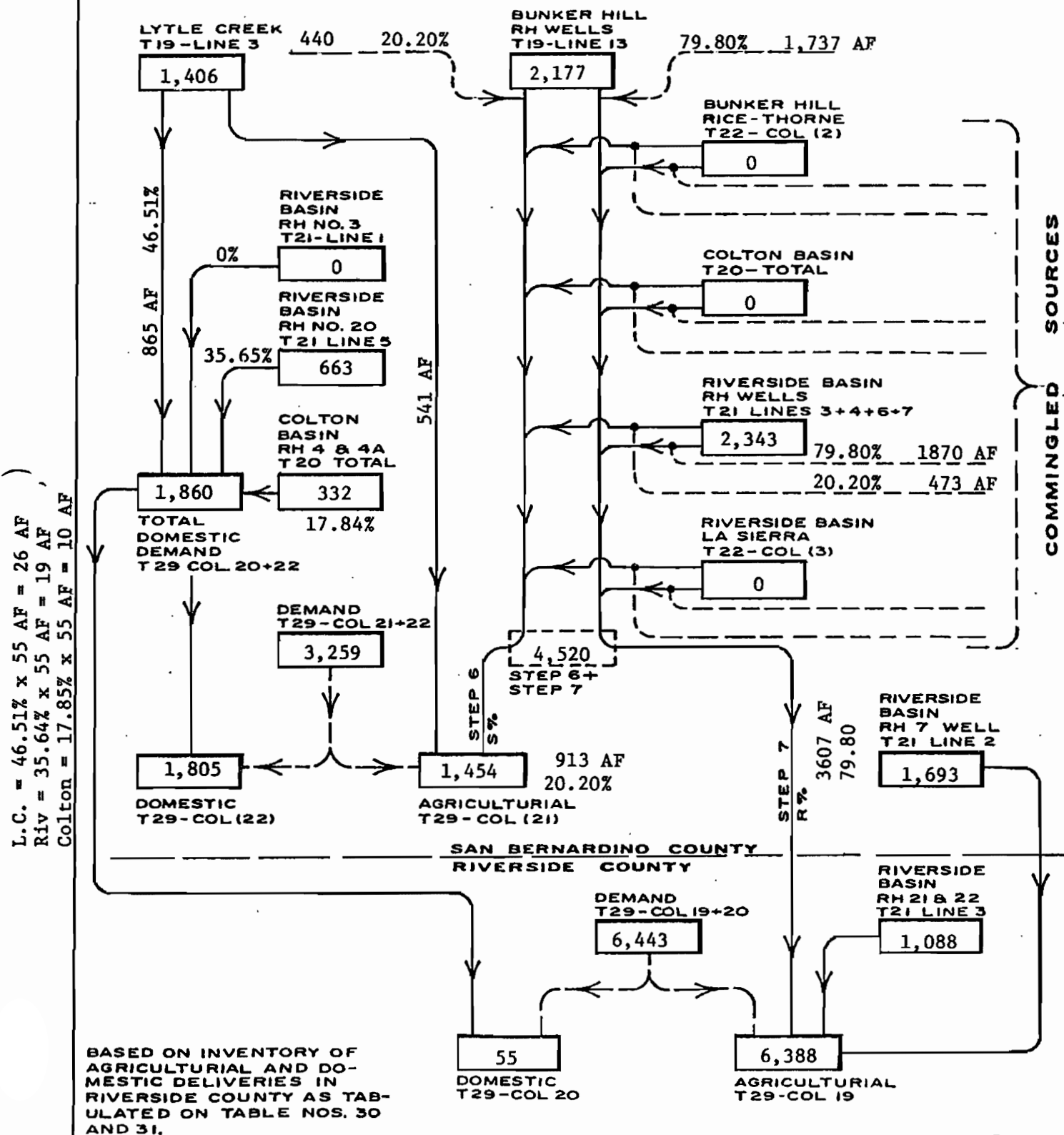


L.C. = 56 x 48.20 = 27
 Riv = 56 x 43.07 = 24
 Colton = 56 x 8.73 = 5

BASED ON INVENTORY OF AGRICULTURAL AND DOMESTIC DELIVERIES IN RIVERSIDE COUNTY AS TABULATED ON TABLE NOS. 30 AND 31.

**RIVERSIDE HIGHLAND WATER COMPANY
DIAGRAM ILLUSTRATING THE PRODUCTION AND DISTRIBUTION
NORTH AND SOUTH OF RIVERSIDE-SAN BERNARDINO CO. LINE**

YEAR 1977

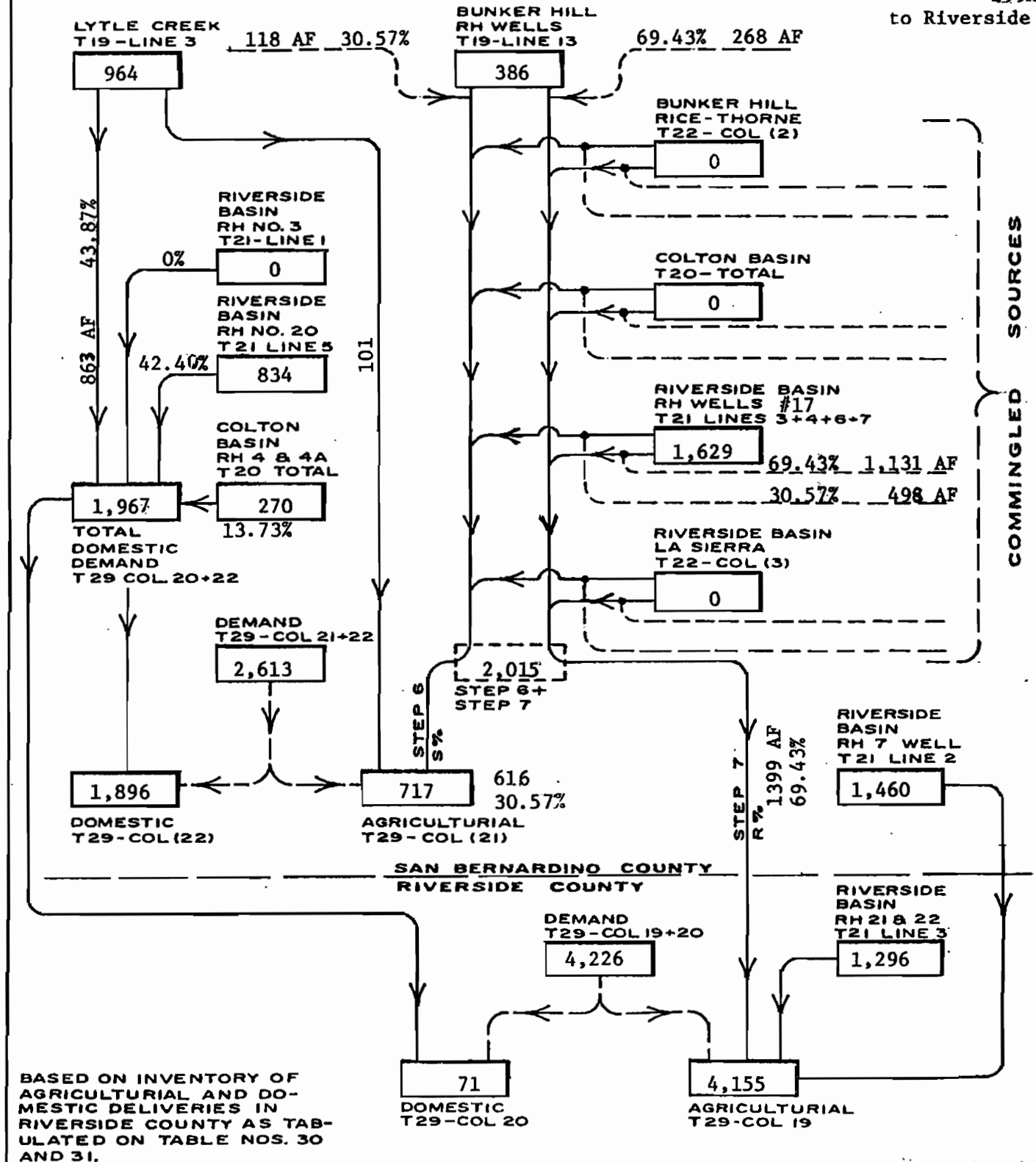


**RIVERSIDE HIGHLAND WATER COMPANY
DIAGRAM ILLUSTRATING THE PRODUCTION AND DISTRIBUTION
NORTH AND SOUTH OF RIVERSIDE-SAN BERNARDINO CO. LINE**

YEAR 1978

Bunker Hill
Flow wells 268
L.C. wells 31
299AF
to Riverside

L.C. = X 43.85% = 31 AF
Riv = X 42.42% = 30 AF
Colt. = 71 X 13.73% = 10 AF

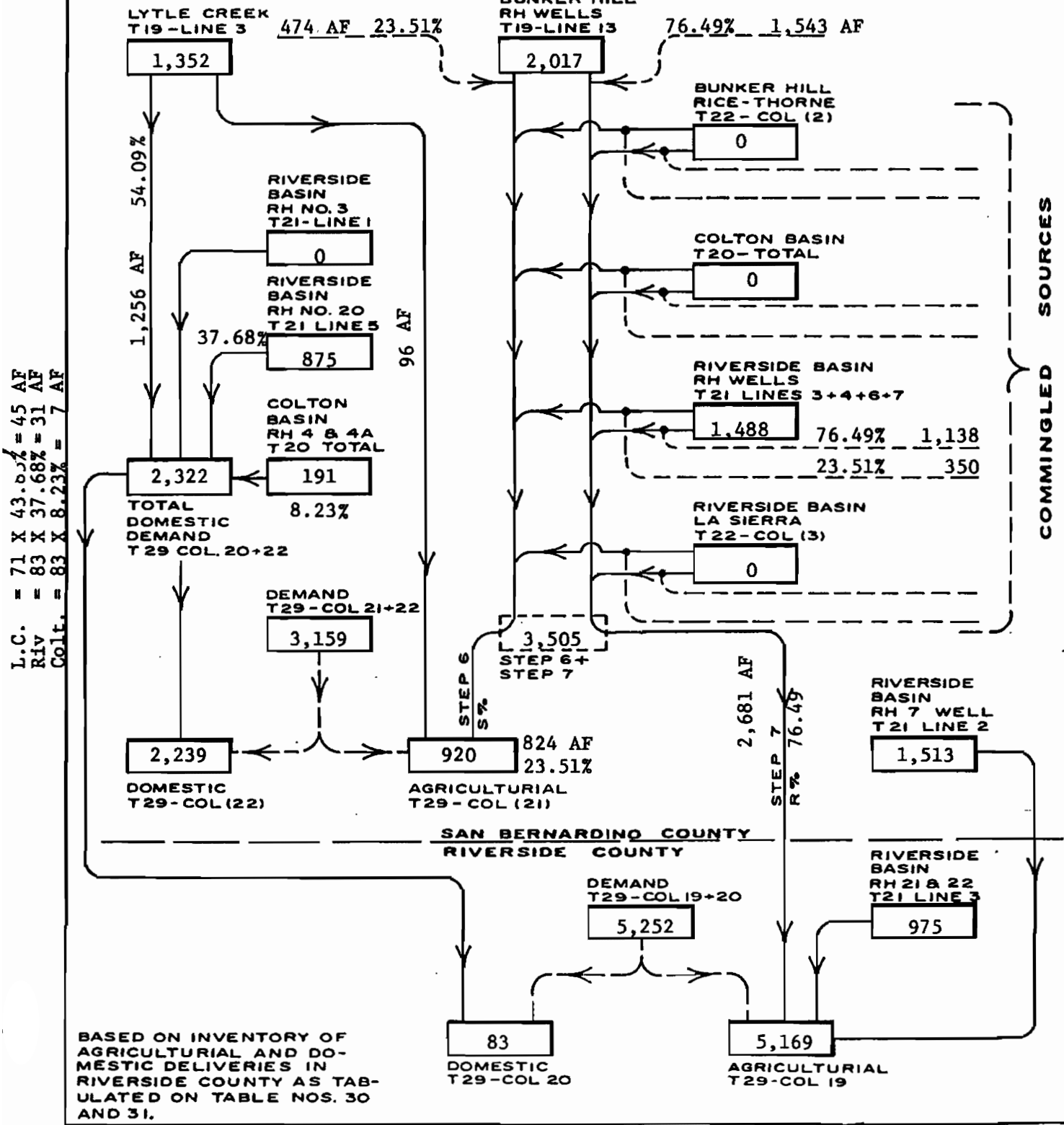


BASED ON INVENTORY OF AGRICULTURAL AND DOMESTIC DELIVERIES IN RIVERSIDE COUNTY AS TABULATED ON TABLE NOS. 30 AND 31.

RIVERSIDE HIGHLAND WATER COMPANY DIAGRAM ILLUSTRATING THE PRODUCTION AND DISTRIBUTION NORTH AND SOUTH OF RIVERSIDE-SAN BERNARDINO CO. LINE

YEAR 1979

BH Export 1,543
45
1,588



L.C. = 71 X 43.05% = 45 AF
 Riv. = 83 X 37.68% = 31 AF
 Colt. = 83 X 8.23% = 7 AF

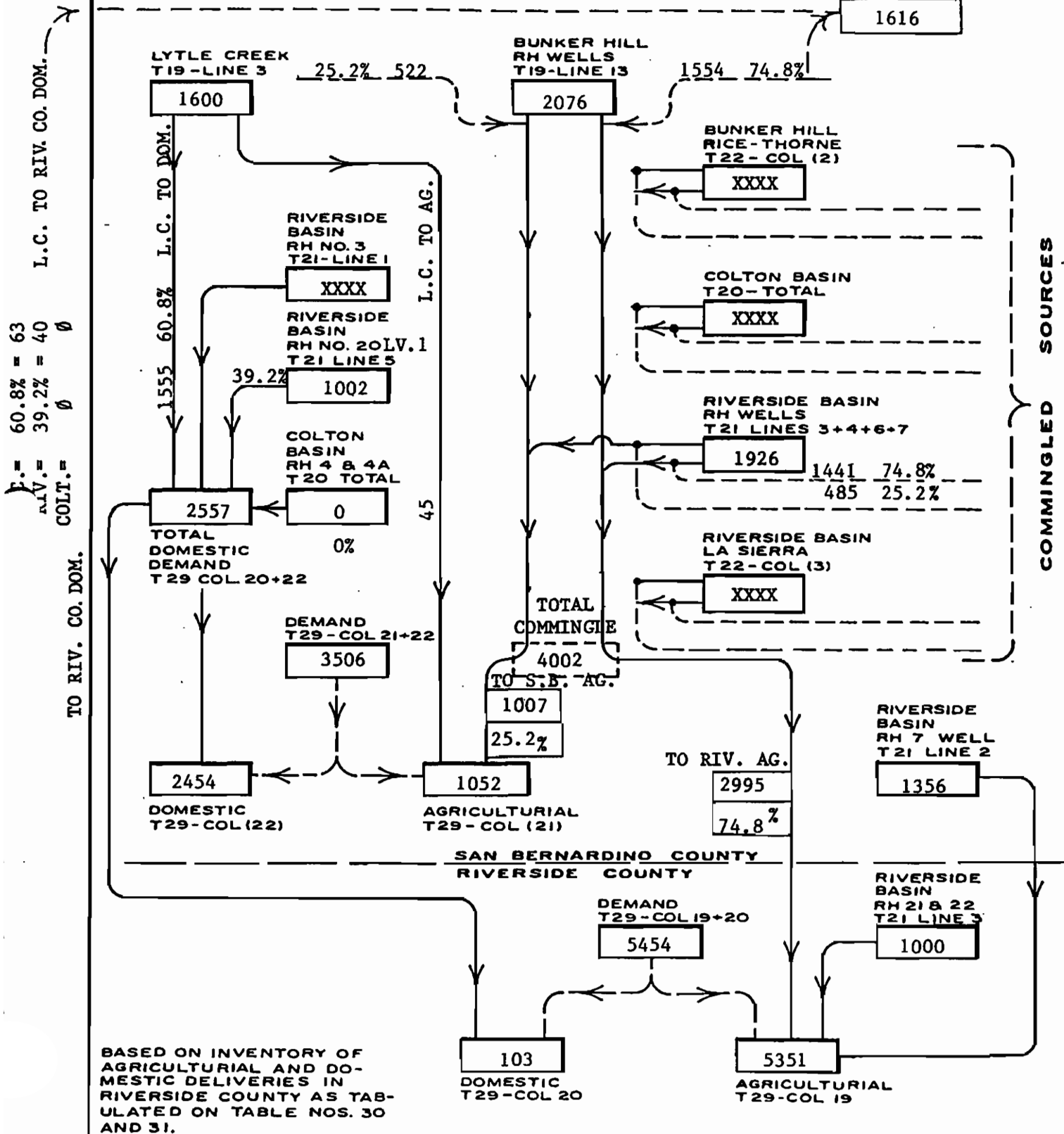
BASED ON INVENTORY OF AGRICULTURAL AND DOMESTIC DELIVERIES IN RIVERSIDE COUNTY AS TABULATED ON TABLE NOS. 30 AND 31.

RIVERSIDE HIGHLAND WATER COMPANY

DIAGRAM ILLUSTRATING THE PRODUCTION AND DISTRIBUTION NORTH AND SOUTH OF RIVERSIDE-SAN BERNARDINO CO. LINE

YEAR 1980

TOTAL BUNKER HILL EXPORT
TO RIVERSIDE COUNTY



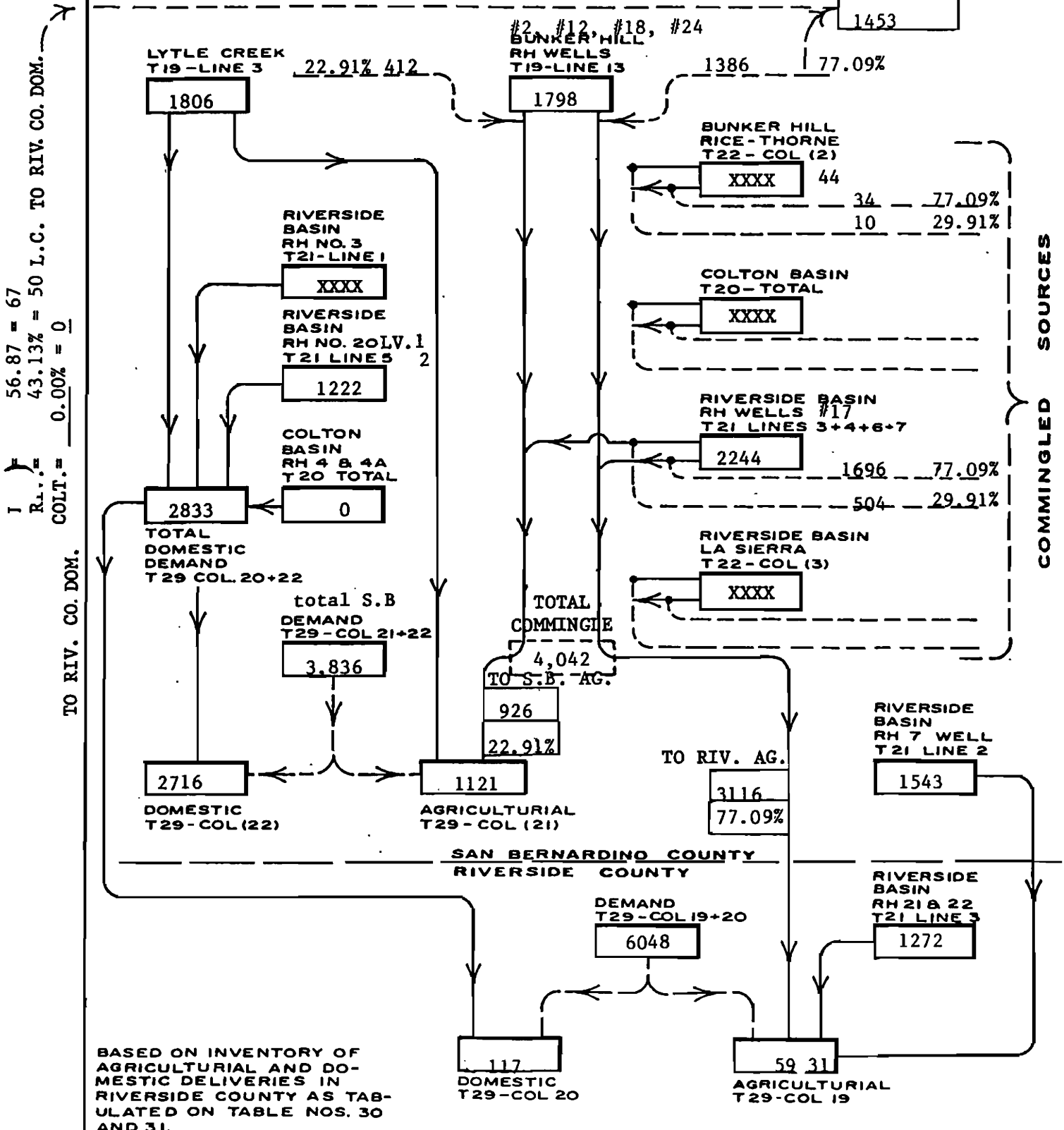
L.C. TO RIV. CO. DOM. = 63
 L.C. TO RIV. CO. AG. = 40
 COLT. = 0

BASED ON INVENTORY OF AGRICULTURAL AND DOMESTIC DELIVERIES IN RIVERSIDE COUNTY AS TABULATED ON TABLE NOS. 30 AND 31.

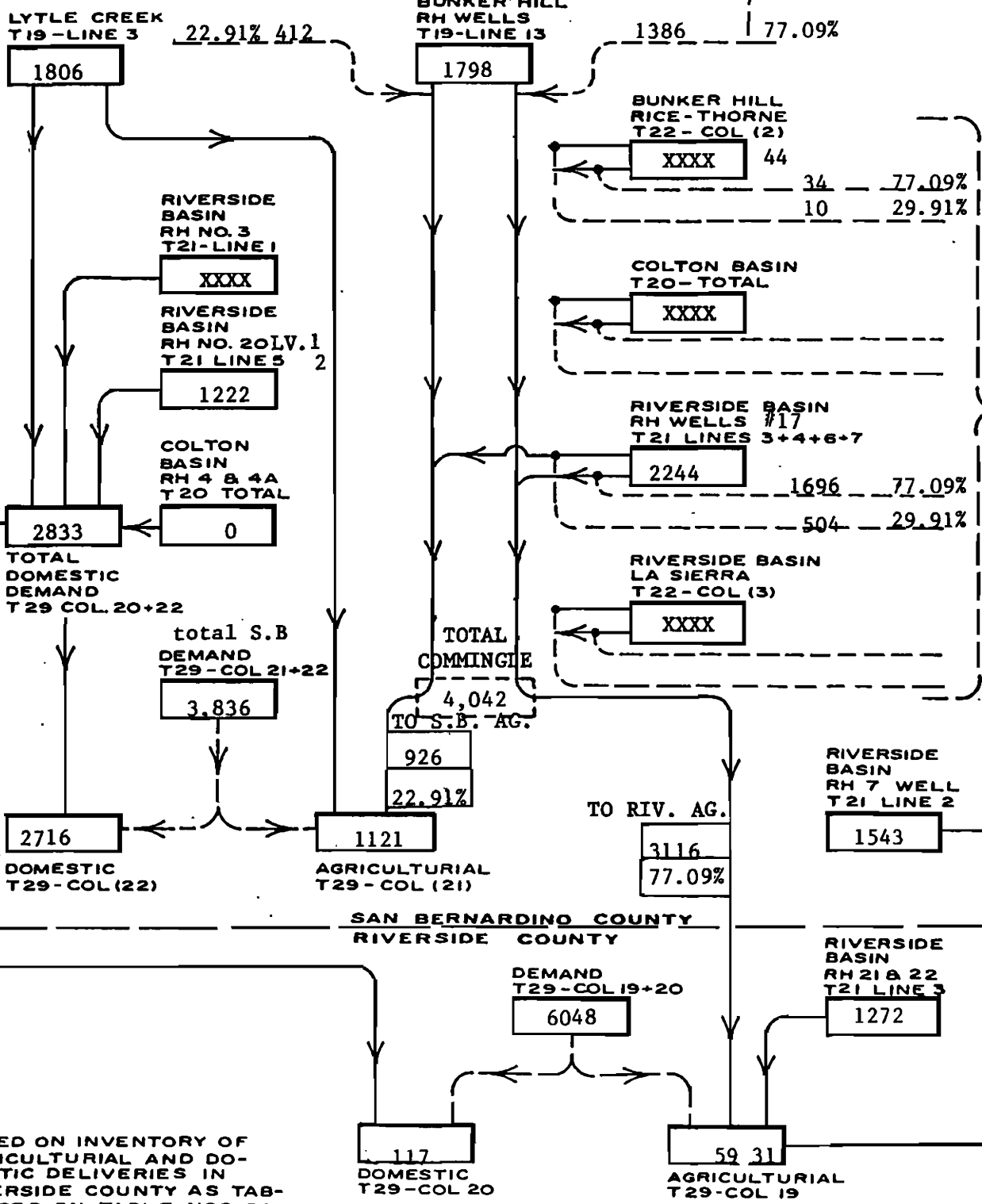
**RIVERSIDE HIGHLAND WATER COMPANY
DIAGRAM ILLUSTRATING THE PRODUCTION AND DISTRIBUTION
NORTH AND SOUTH OF RIVERSIDE-SAN BERNARDINO CO. LINE**

YEAR 1981

TOTAL BUNKER HILL EXPORT
TO RIVERSIDE COUNTY



56.87 = 67
43.13% = 50 L.C. TO RIV. CO. DOM.
COLT. = 0.00% = 0

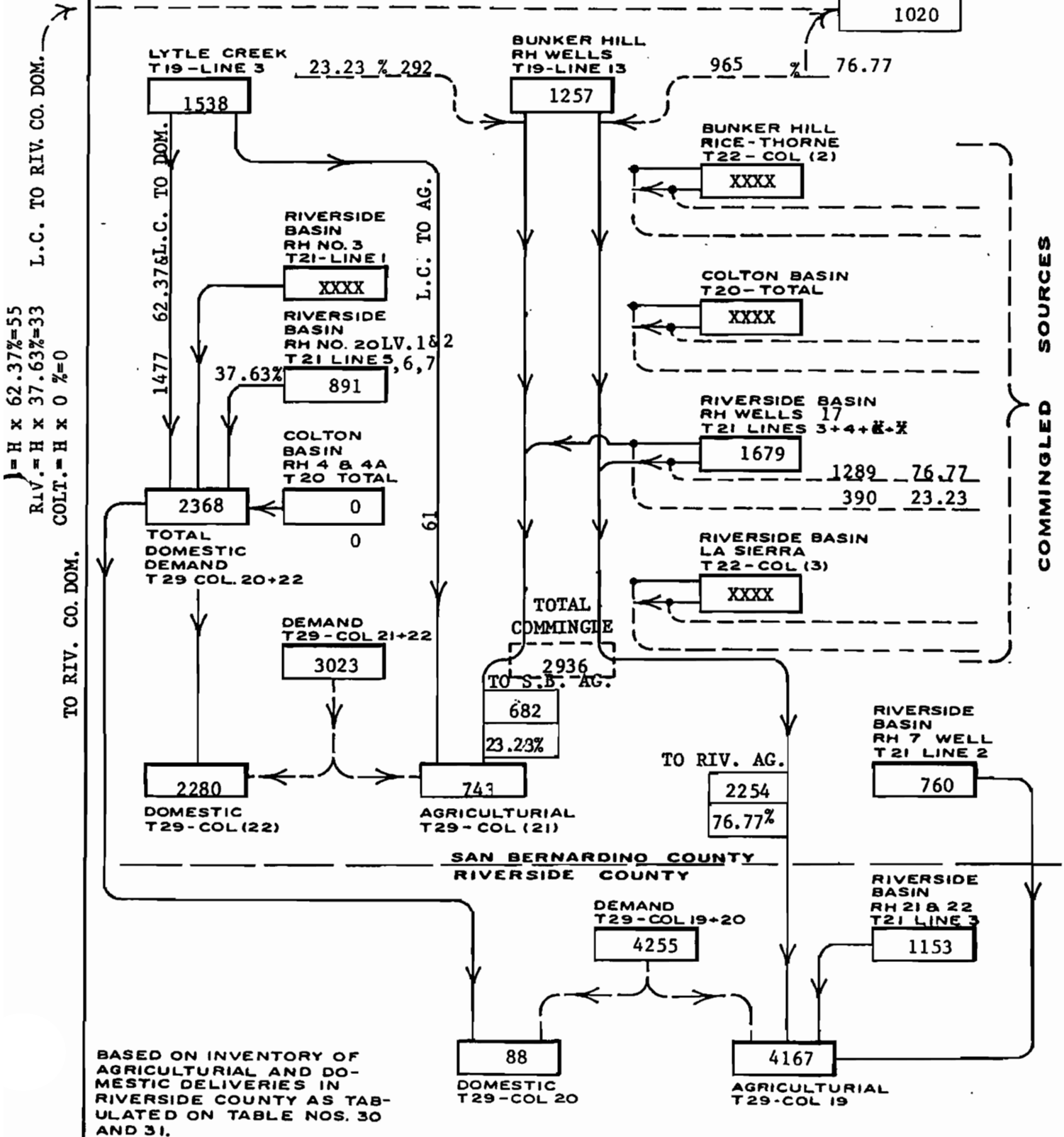


XXX NOT IN USE

**RIVERSIDE HIGHLAND WATER COMPANY
DIAGRAM ILLUSTRATING THE PRODUCTION AND DISTRIBUTION
NORTH AND SOUTH OF RIVERSIDE-SAN BERNARDINO CO. LINE**

YEAR 1982

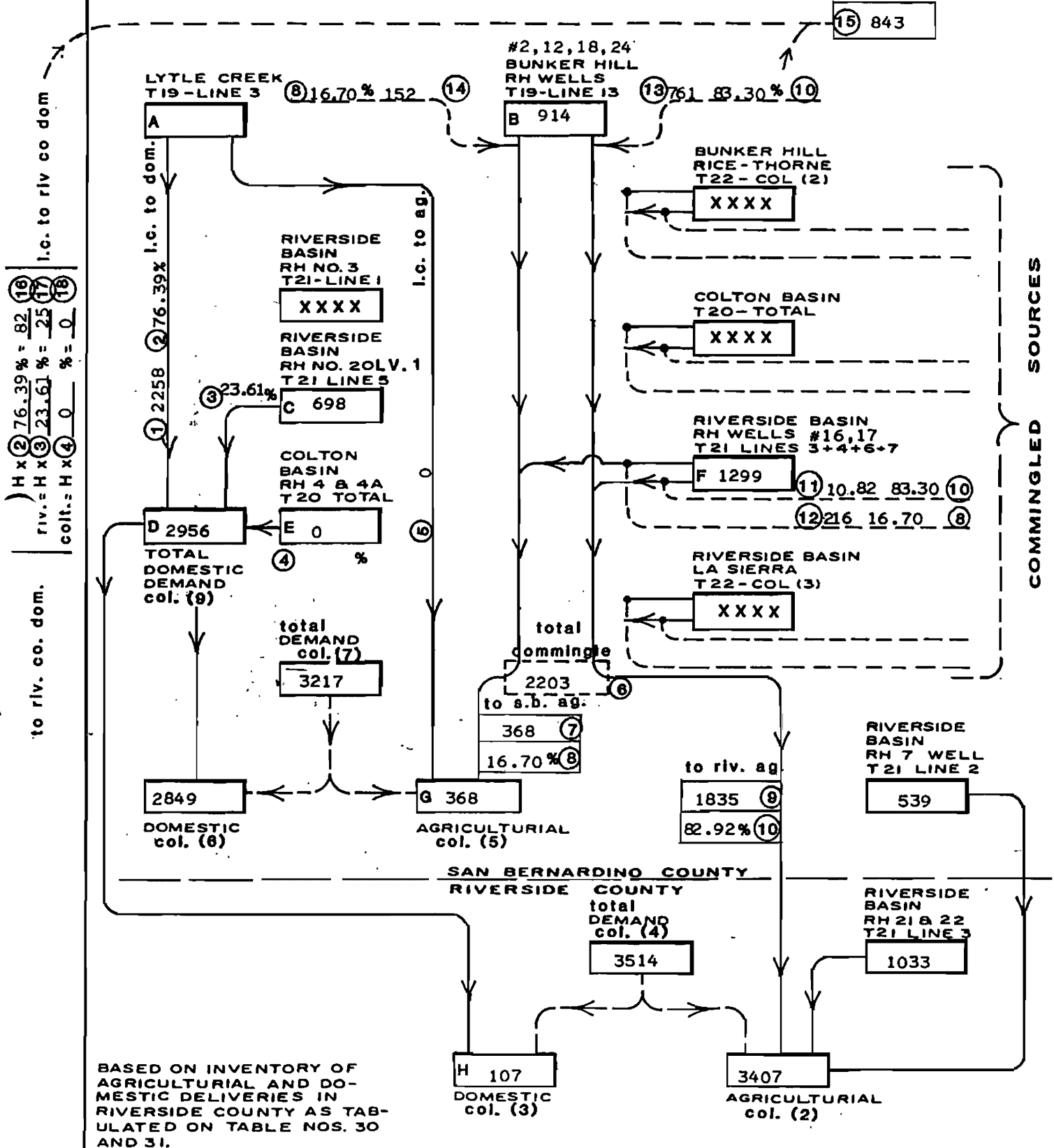
TOTAL BUNKER HILL EXPORT
TO RIVERSIDE COUNTY



RIVERSIDE HIGHLAND WATER COMPANY DIAGRAM ILLUSTRATING THE PRODUCTION AND DISTRIBUTION NORTH AND SOUTH OF RIVERSIDE-SAN BERNARDINO CO. LINE

YEAR 1983

total bunker hill export
to riverside county



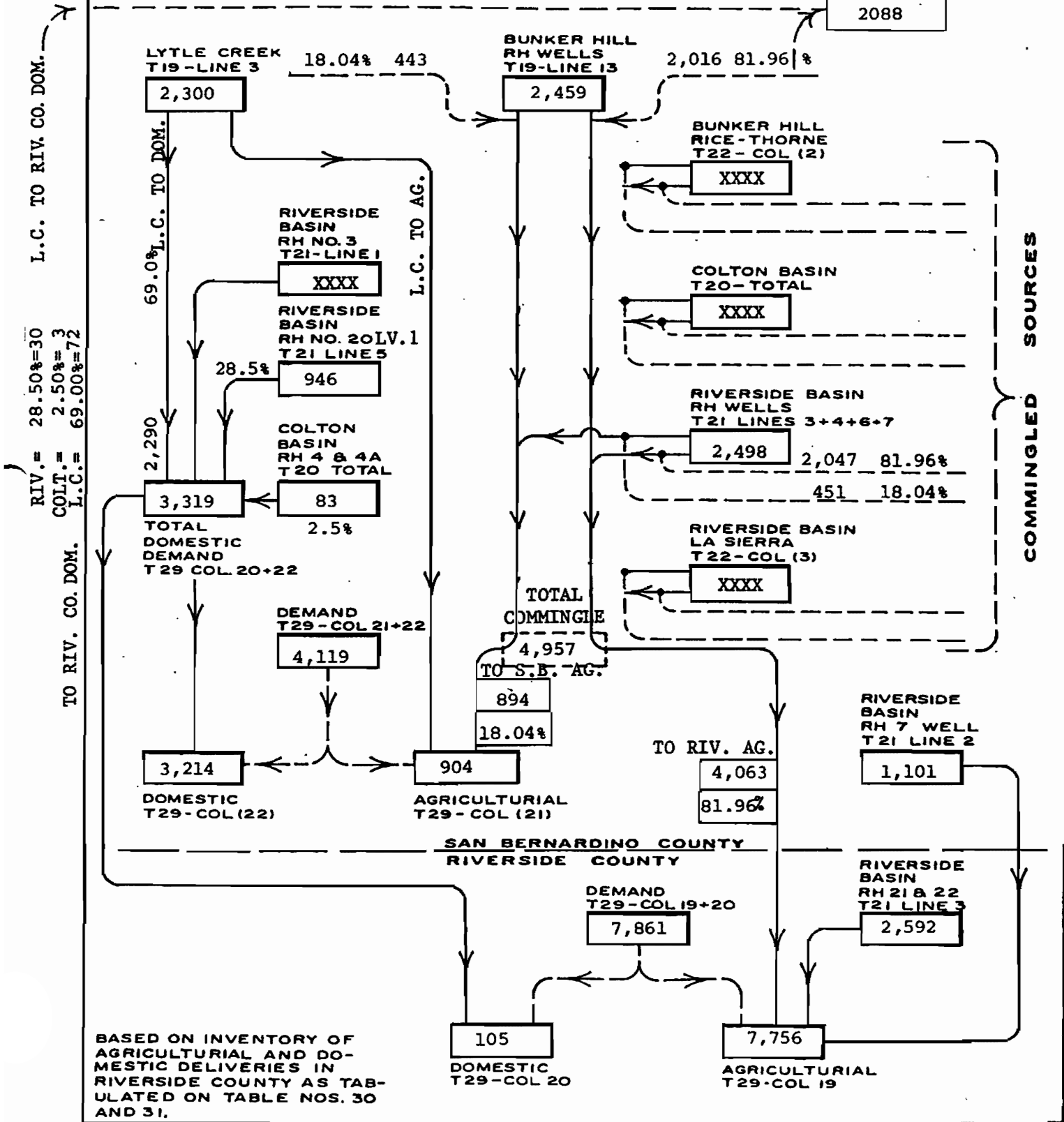
BASED ON INVENTORY OF AGRICULTURAL AND DOMESTIC DELIVERIES IN RIVERSIDE COUNTY AS TABULATED ON TABLE NOS. 30 AND 31.

**RIVERSIDE HIGHLAND WATER COMPANY
DIAGRAM ILLUSTRATING THE PRODUCTION AND DISTRIBUTION
NORTH AND SOUTH OF RIVERSIDE-SAN BERNARDINO CO. LINE**

YEAR 1984

TOTAL BUNKER HILL EXPORT
TO RIVERSIDE COUNTY

2088

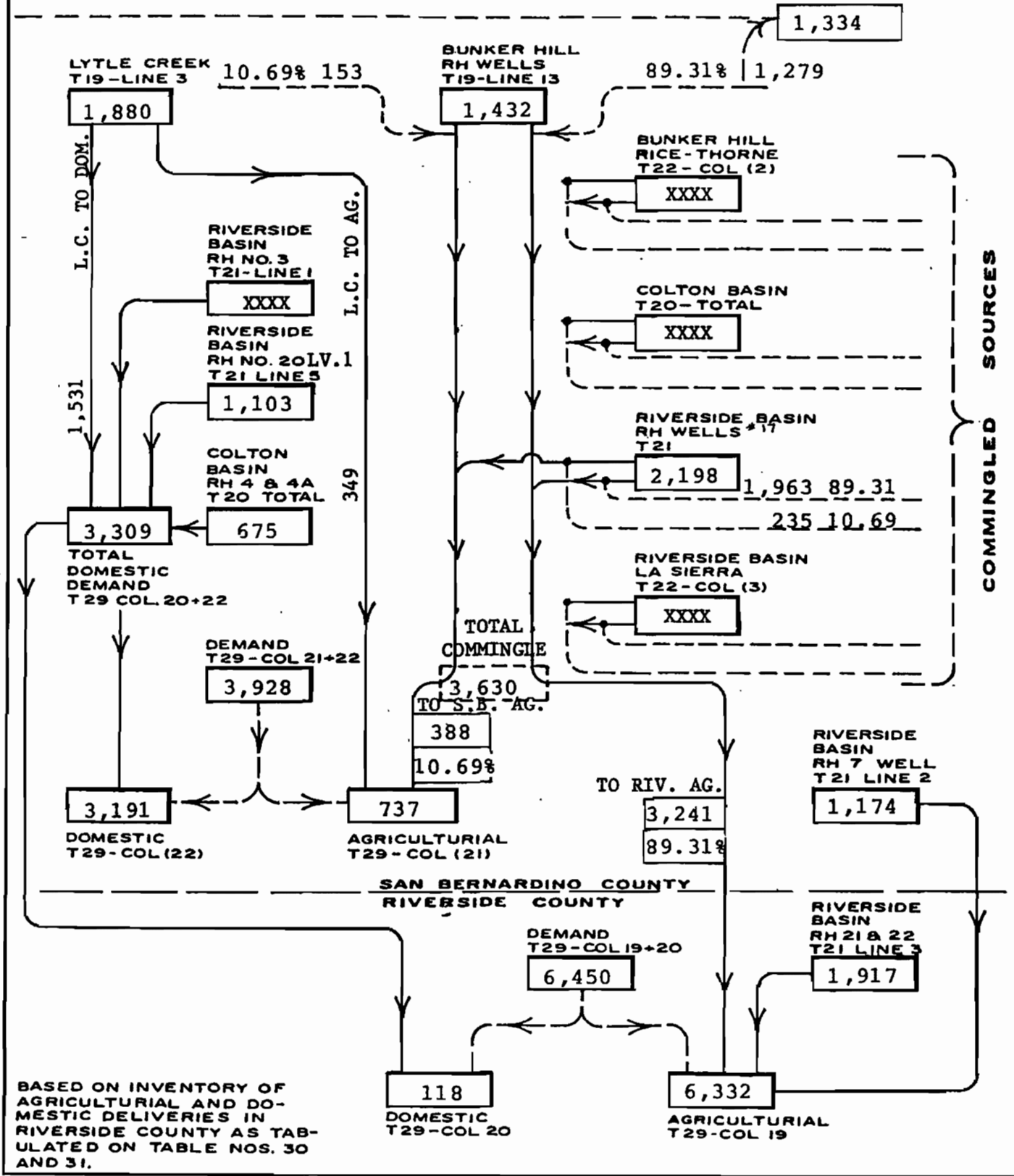


BASED ON INVENTORY OF AGRICULTURAL AND DOMESTIC DELIVERIES IN RIVERSIDE COUNTY AS TABULATED ON TABLE NOS. 30 AND 31.

**RIVERSIDE HIGHLAND WATER COMPANY
DIAGRAM ILLUSTRATING THE PRODUCTION AND DISTRIBUTION
NORTH AND SOUTH OF RIVERSIDE-SAN BERNARDINO CO. LINE**

YEAR 1985

TOTAL BUNKER HILL EXPORT
TO RIVERSIDE COUNTY



TO RIV. CO. DOM. L.C. TO RIV. CO. DOM.

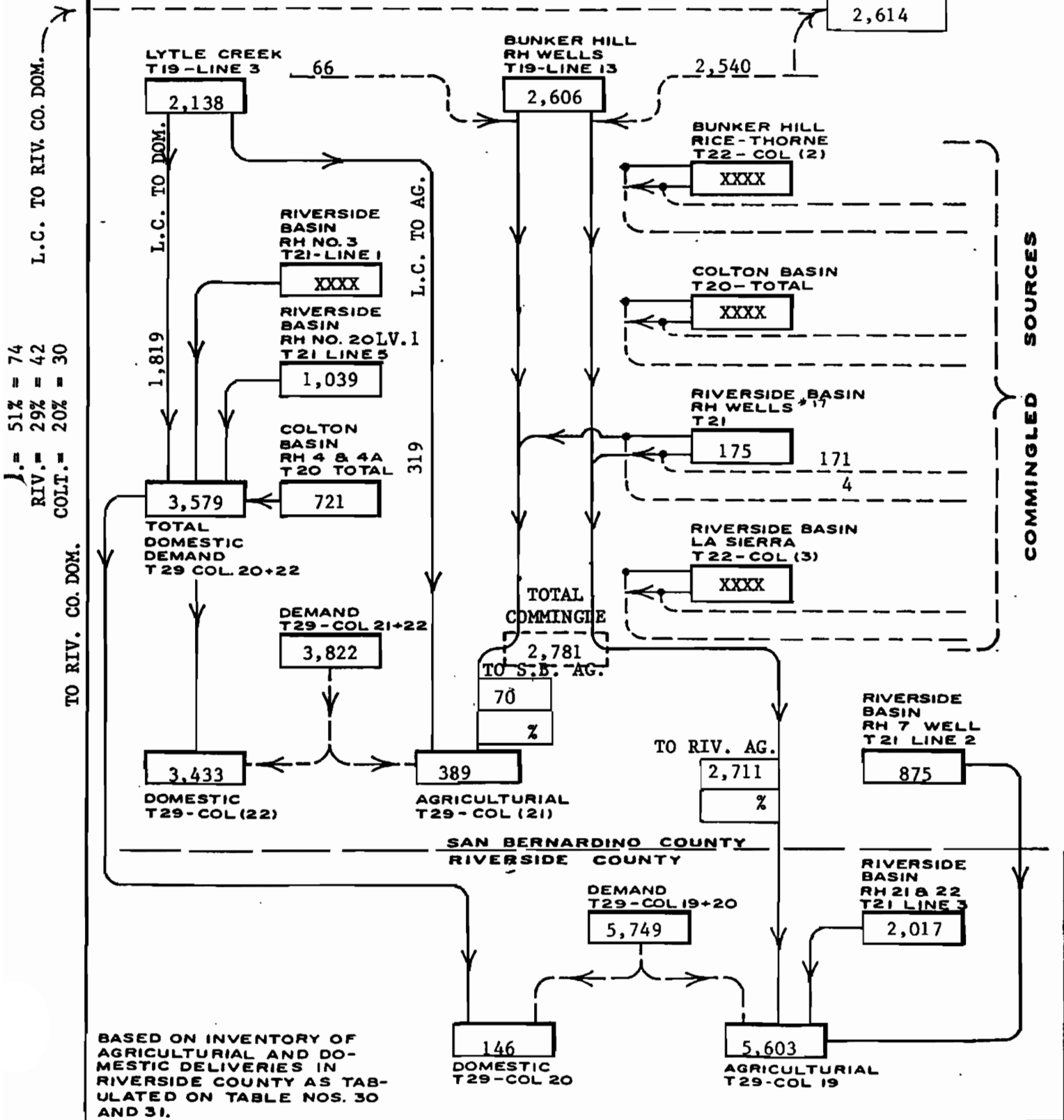
$\frac{55}{RIV.} = \frac{46.27}{\%}$
 $\frac{39}{COLT.} = \frac{33.33}{\%}$
 $\frac{24}{\%} = \frac{20.40}{\%}$

BASED ON INVENTORY OF AGRICULTURAL AND DOMESTIC DELIVERIES IN RIVERSIDE COUNTY AS TABULATED ON TABLE NOS. 30 AND 31.

**RIVERSIDE HIGHLAND WATER COMPANY
DIAGRAM ILLUSTRATING THE PRODUCTION AND DISTRIBUTION
NORTH AND SOUTH OF RIVERSIDE-SAN BERNARDINO CO. LINE**

YEAR 1986

TOTAL BUNKER HILL EXPORT
TO RIVERSIDE COUNTY

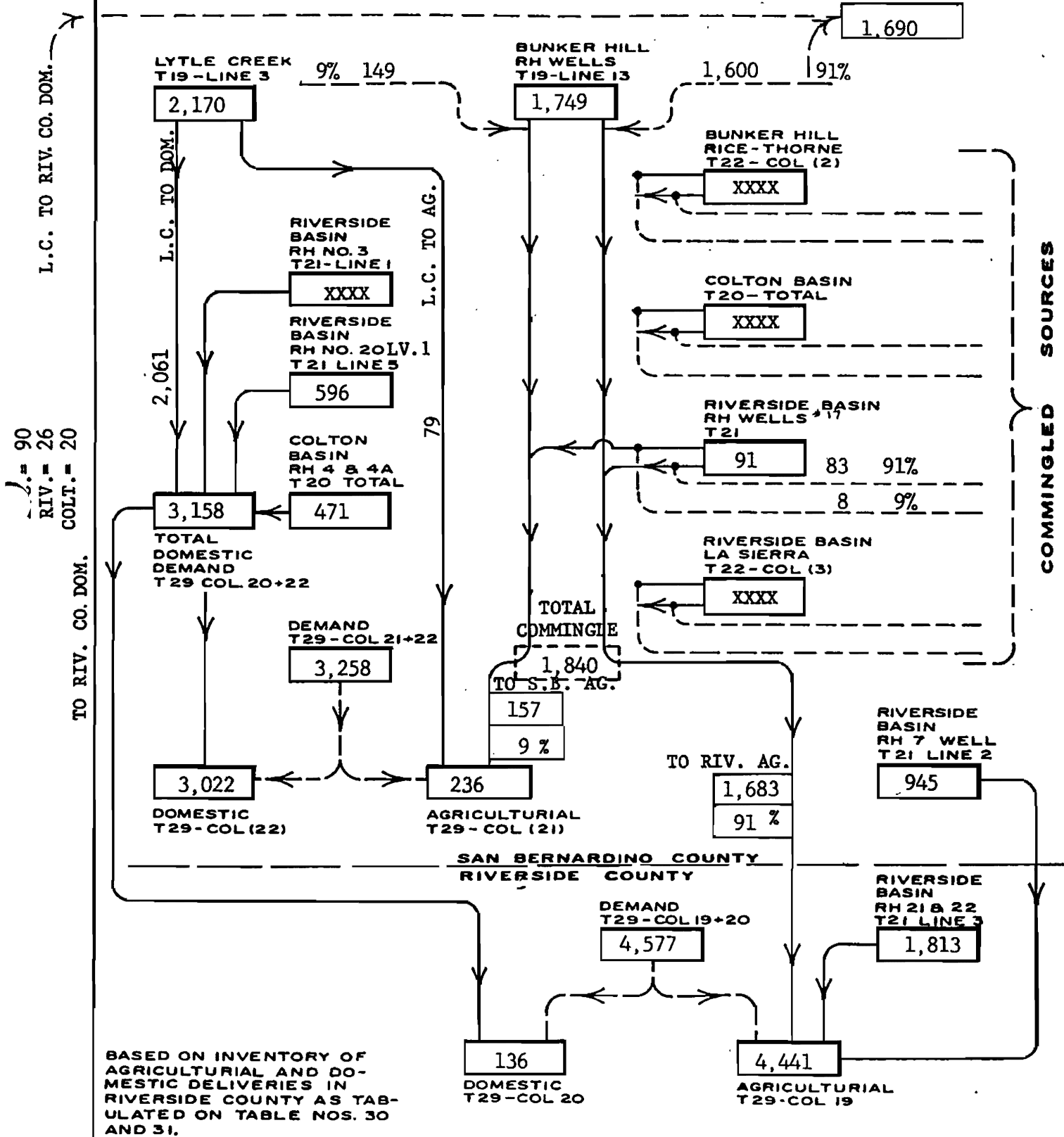


BASED ON INVENTORY OF AGRICULTURAL AND DOMESTIC DELIVERIES IN RIVERSIDE COUNTY AS TABULATED ON TABLE NOS. 30 AND 31.

**RIVERSIDE HIGHLAND WATER COMPANY
DIAGRAM ILLUSTRATING THE PRODUCTION AND DISTRIBUTION
NORTH AND SOUTH OF RIVERSIDE-SAN BERNARDINO CO. LINE**

YEAR 1987

TOTAL BUNKER HILL EXPORT
TO RIVERSIDE COUNTY

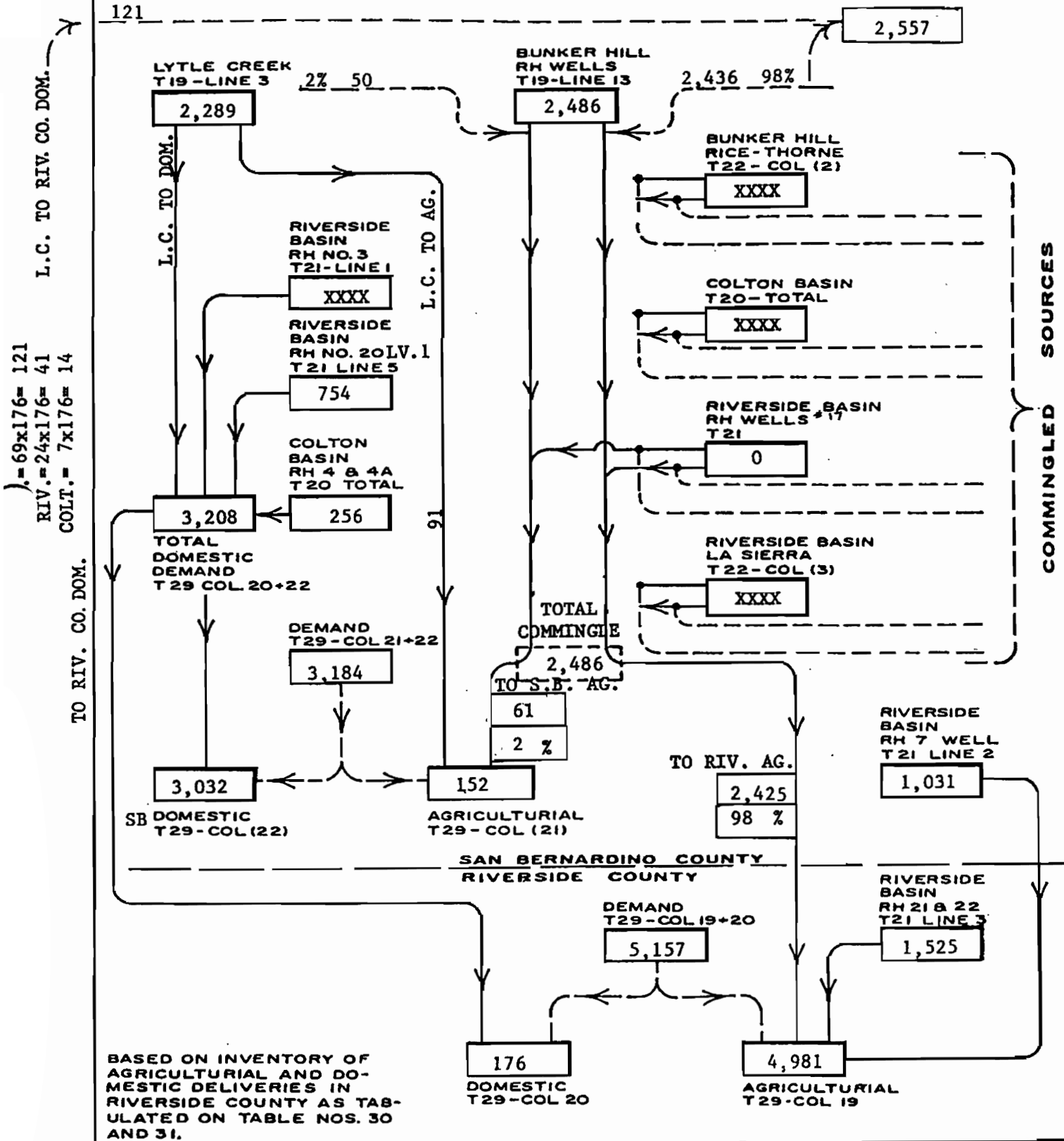


XXX NOT IN USE

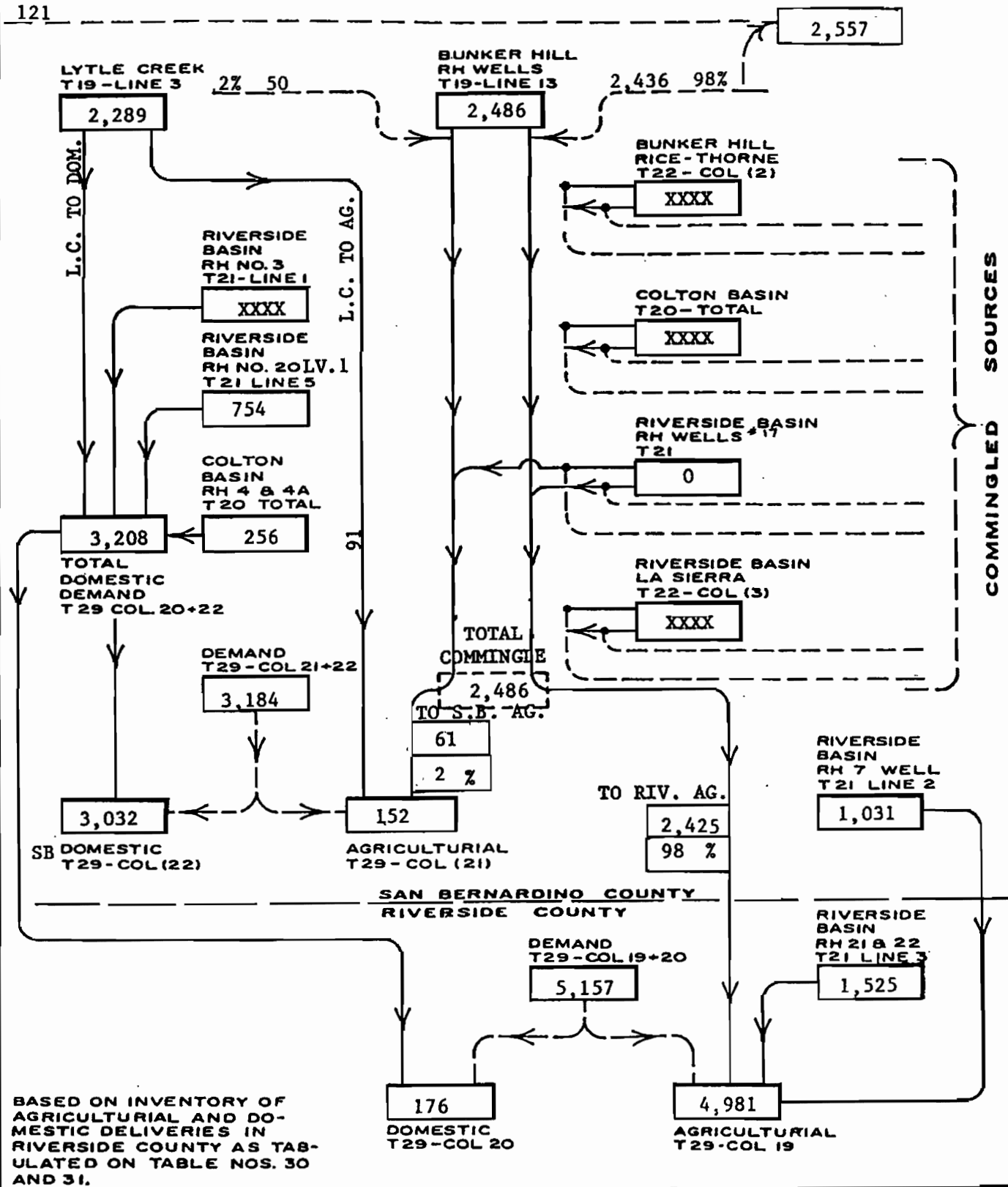
**RIVERSIDE HIGHLAND WATER COMPANY
DIAGRAM ILLUSTRATING THE PRODUCTION AND DISTRIBUTION
NORTH AND SOUTH OF RIVERSIDE-SAN BERNARDINO CO. LINE**

YEAR 1988

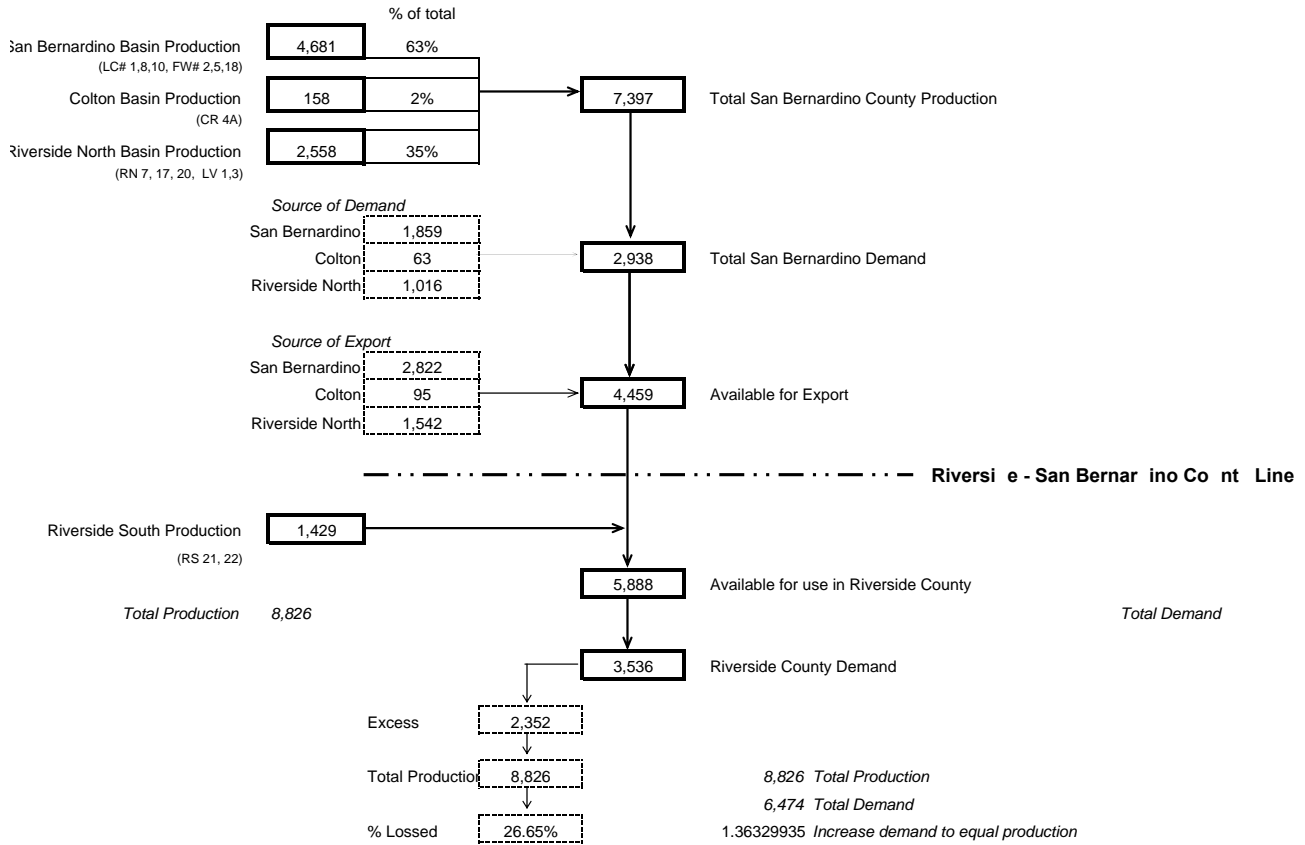
TOTAL BUNKER HILL EXPORT
TO RIVERSIDE COUNTY



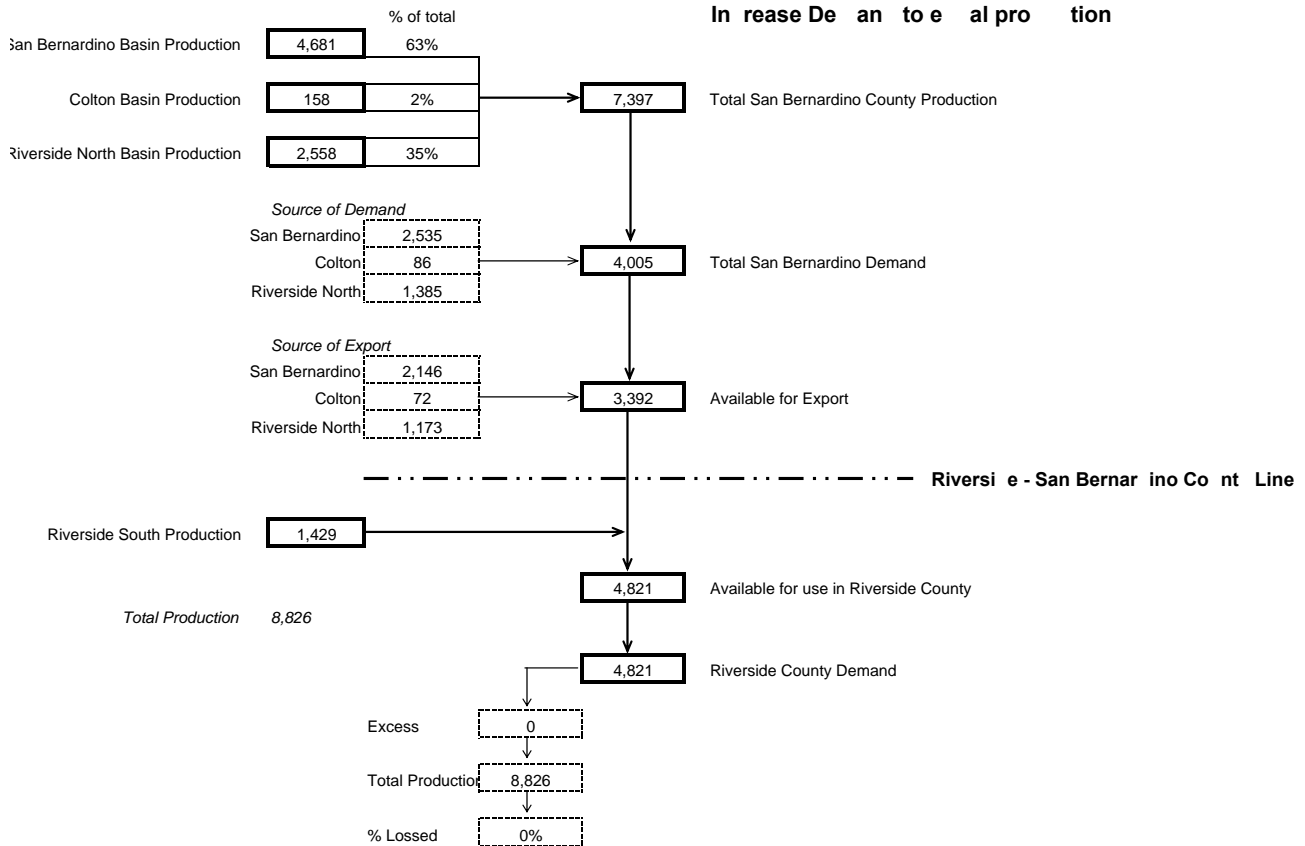
69x176= 121
RIV.=24x176= 41
COLT.= 7x176= 14



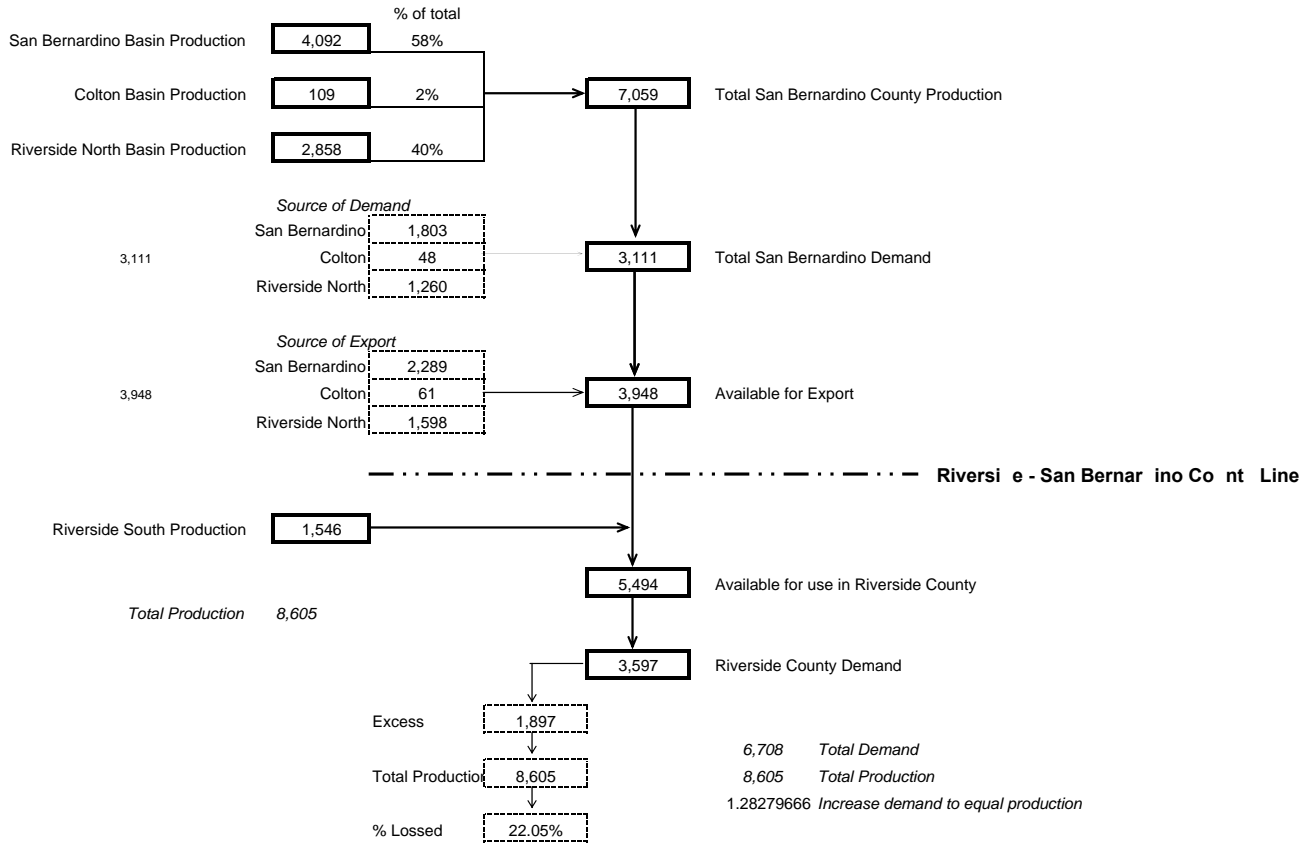
Riverside Hills Water Company 1989 Water Supply Distribution



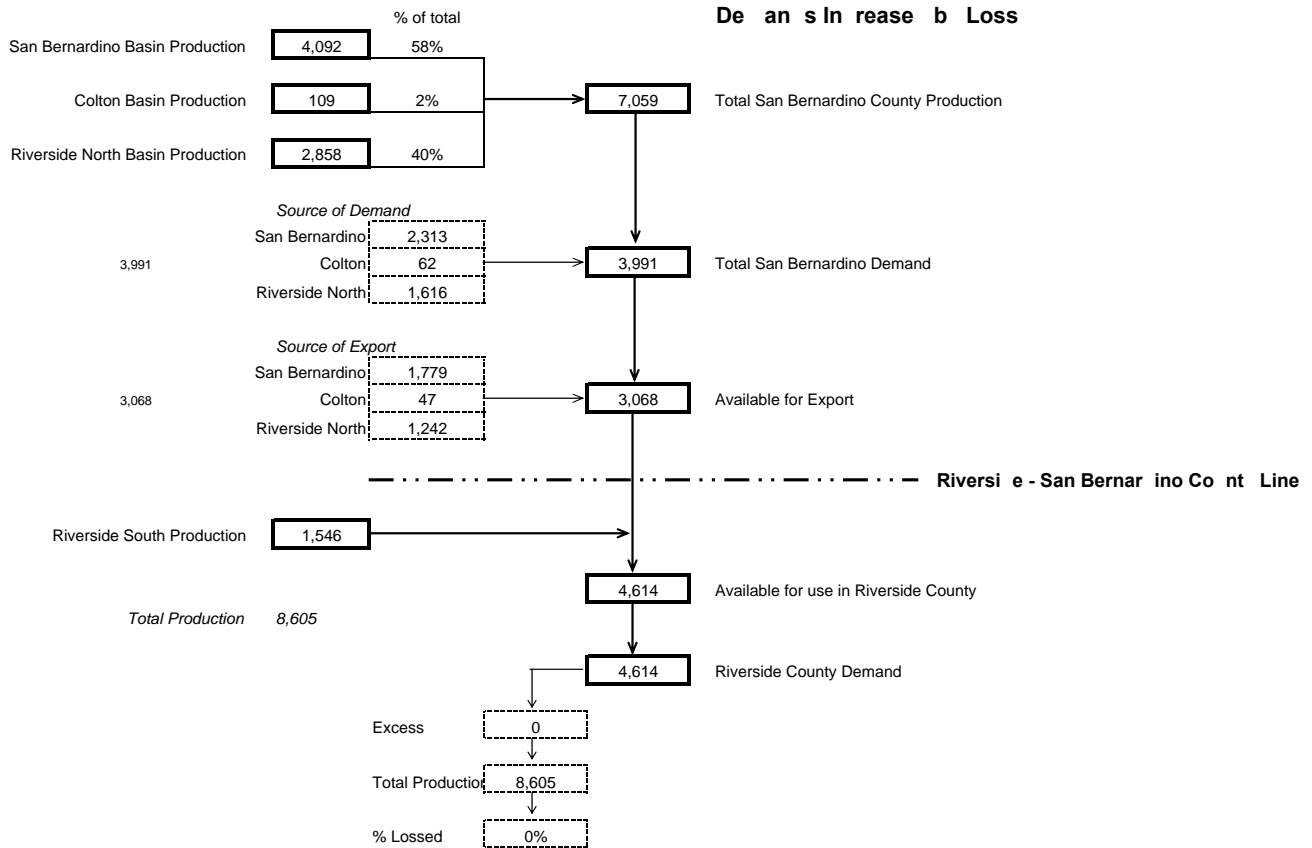
Increase Demand to Equal Production



Riverside Hills Water Company 1990 Water Supply Distribution

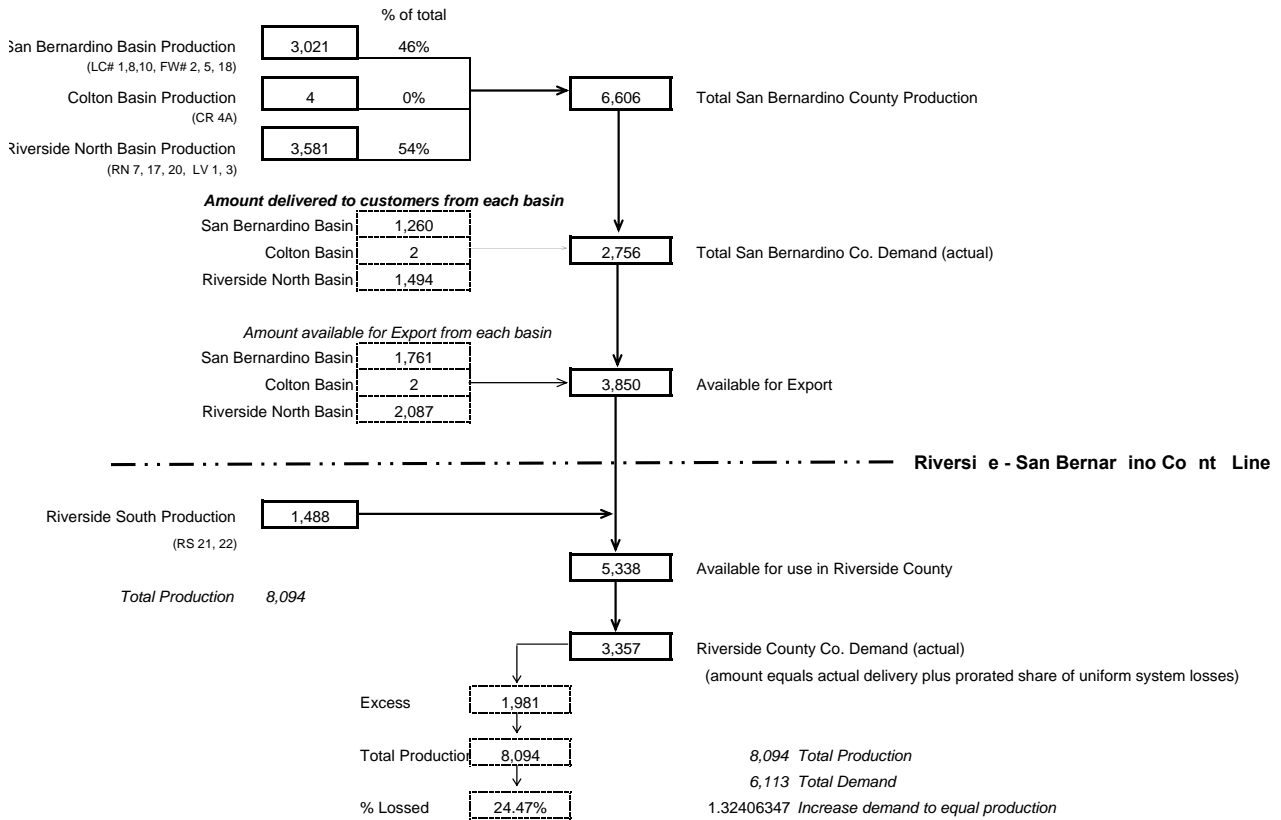


Design Increase by Loss

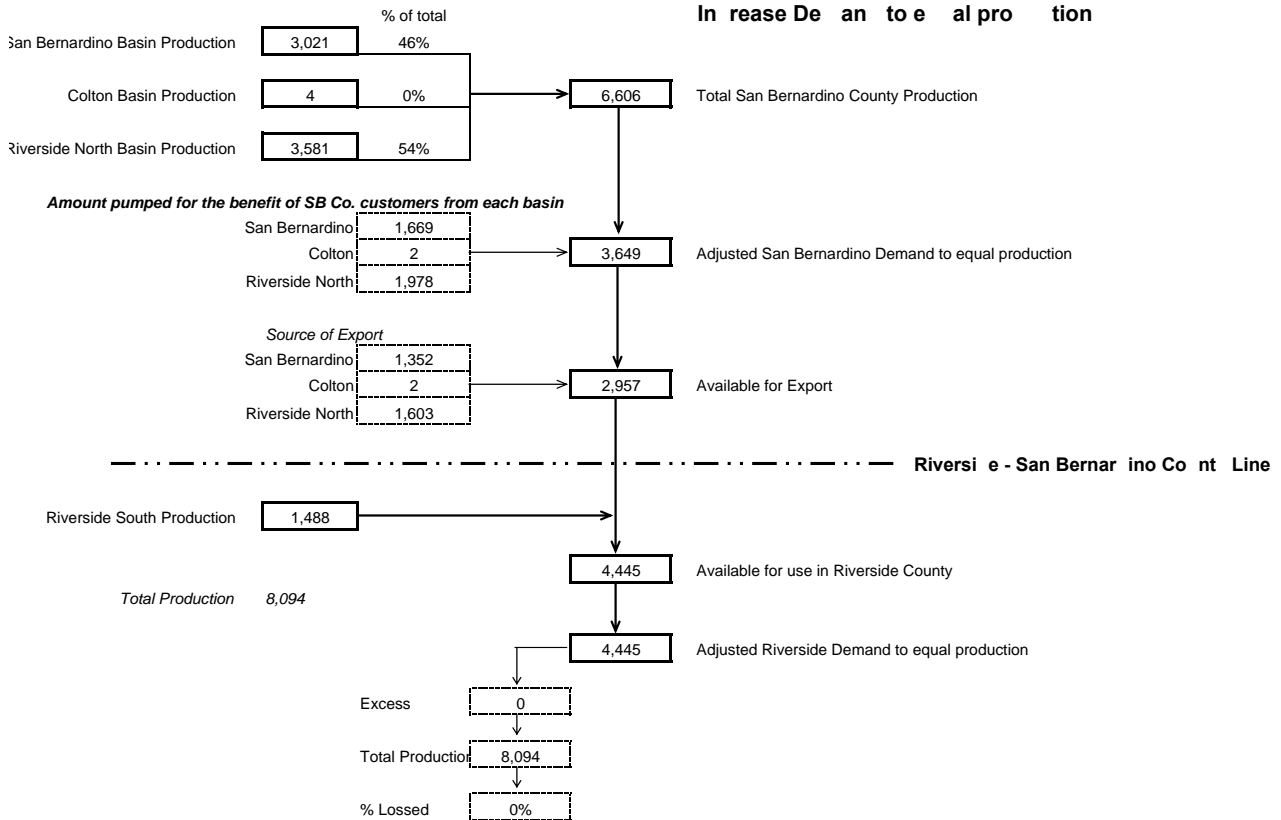


Dia ra B

**Riverside Hi l an Water Co pan
1991 Water S ppl Distrib tion**

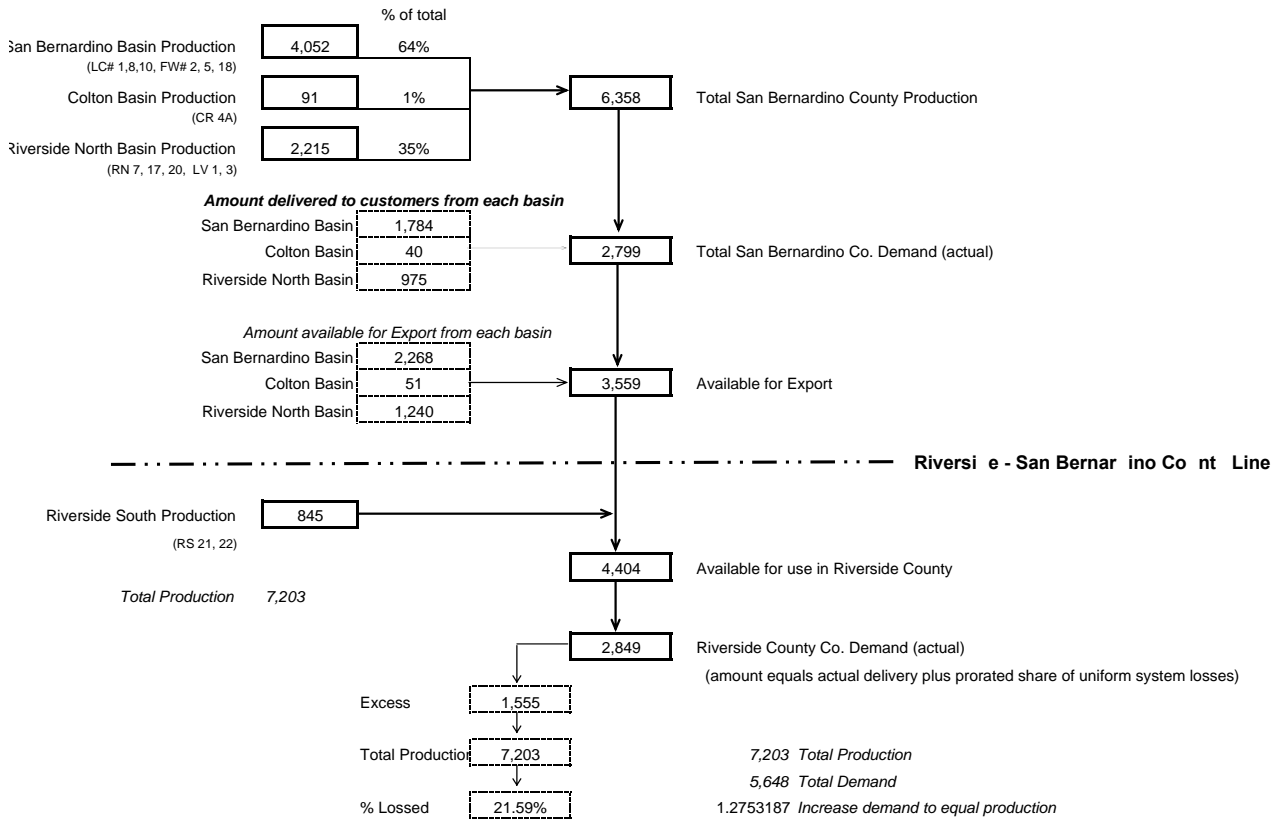


In rease De an to e al pro tion

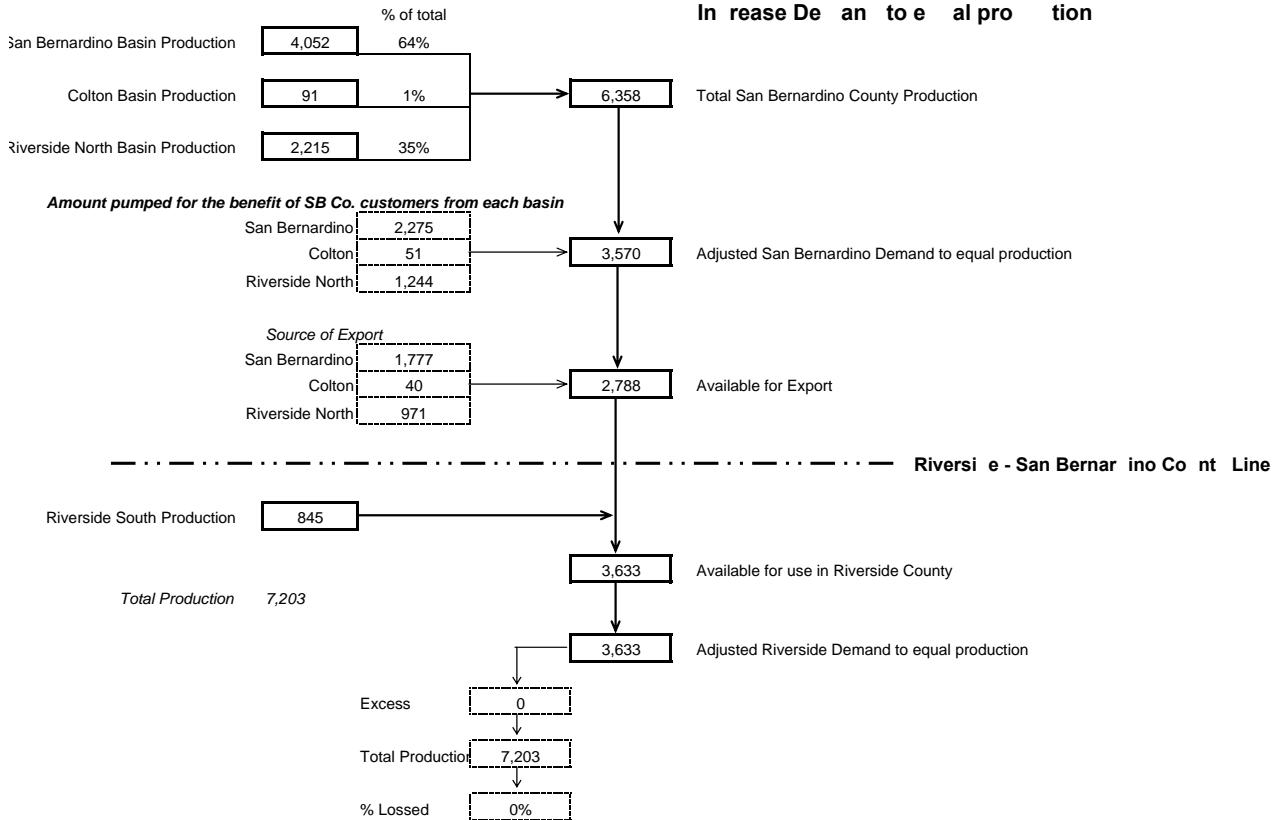


Dia ra B

Riversi e Hi lan Water Co pan 1992 Water S ppl Distrib tion

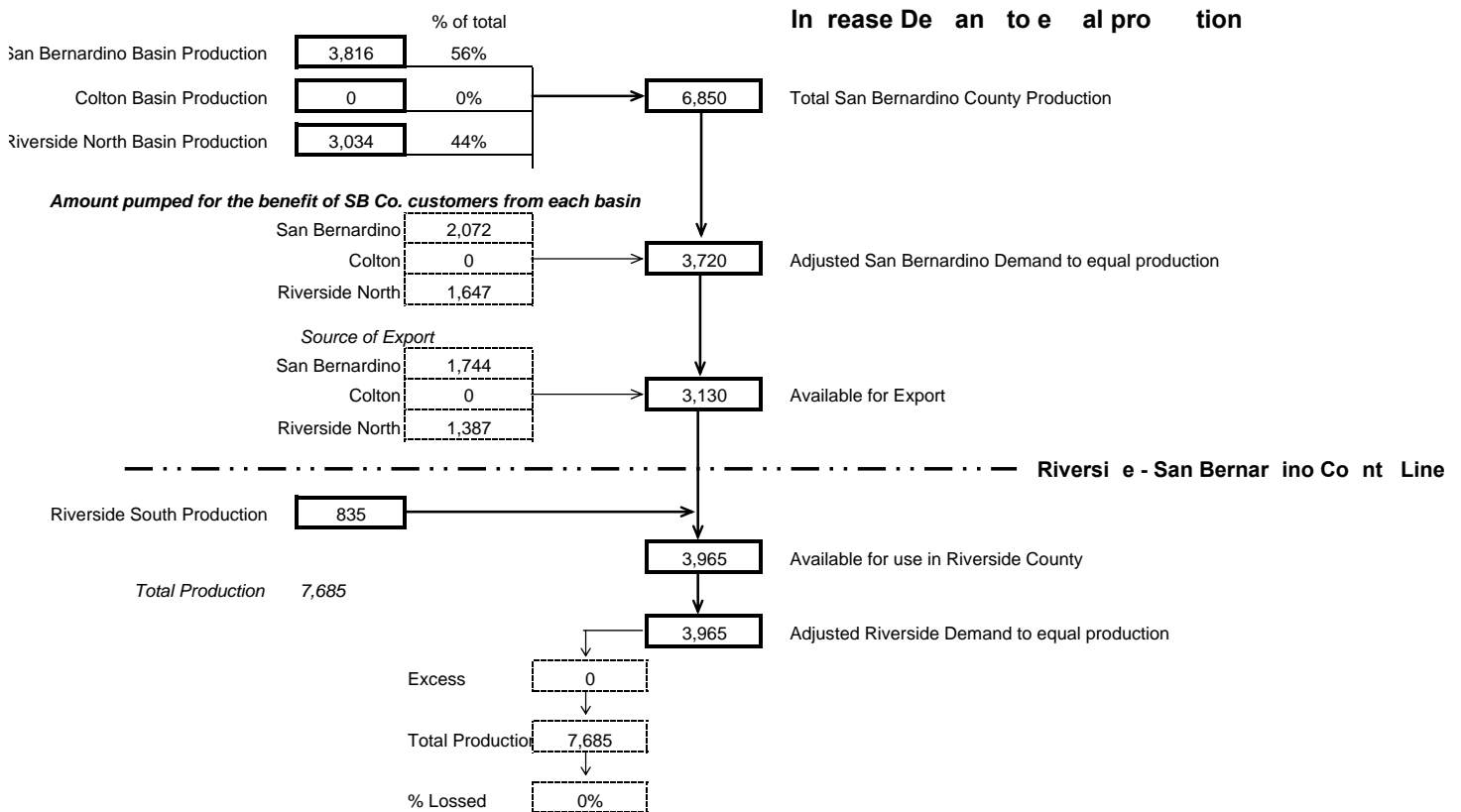
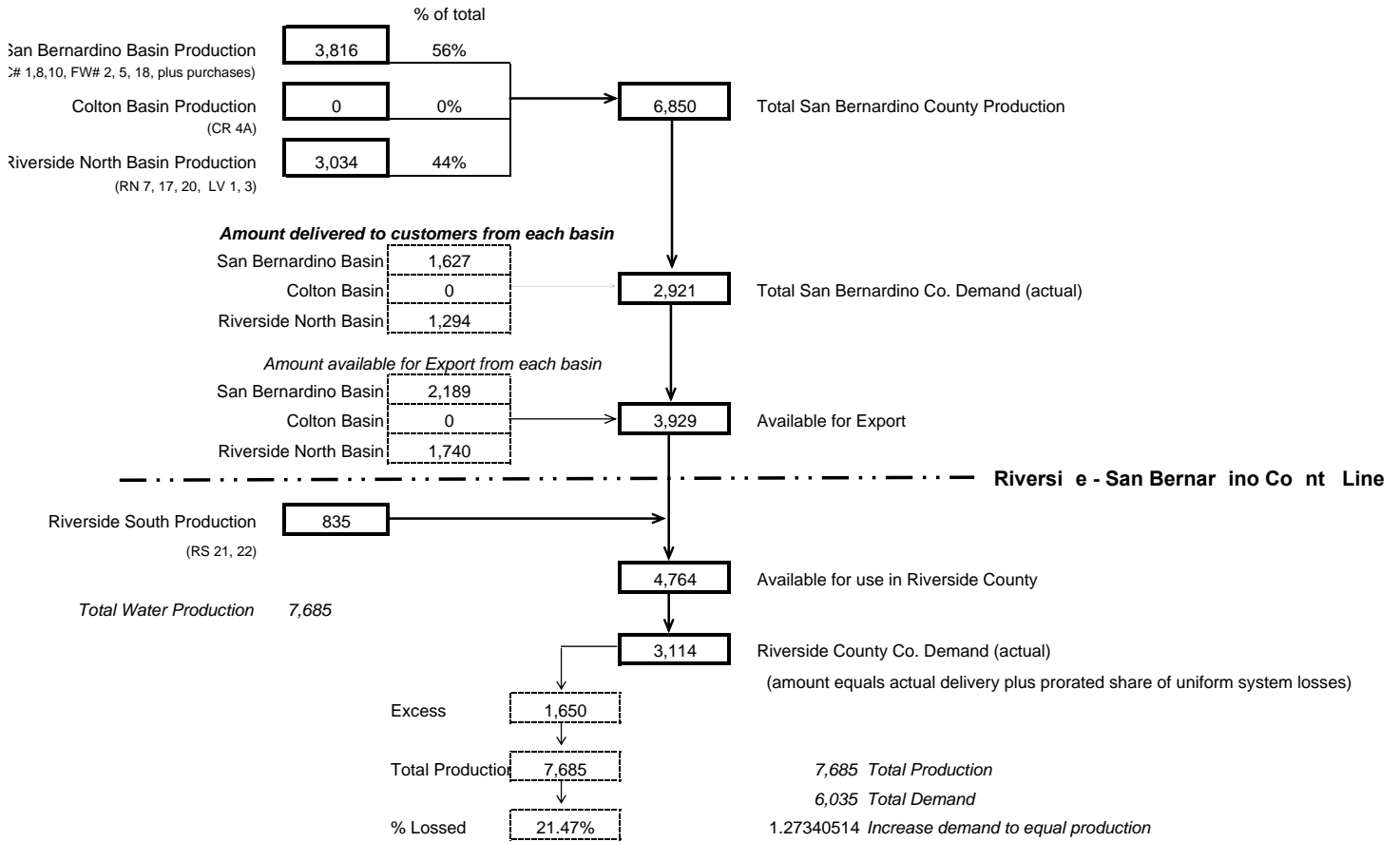


In rease De an to e al pro tion



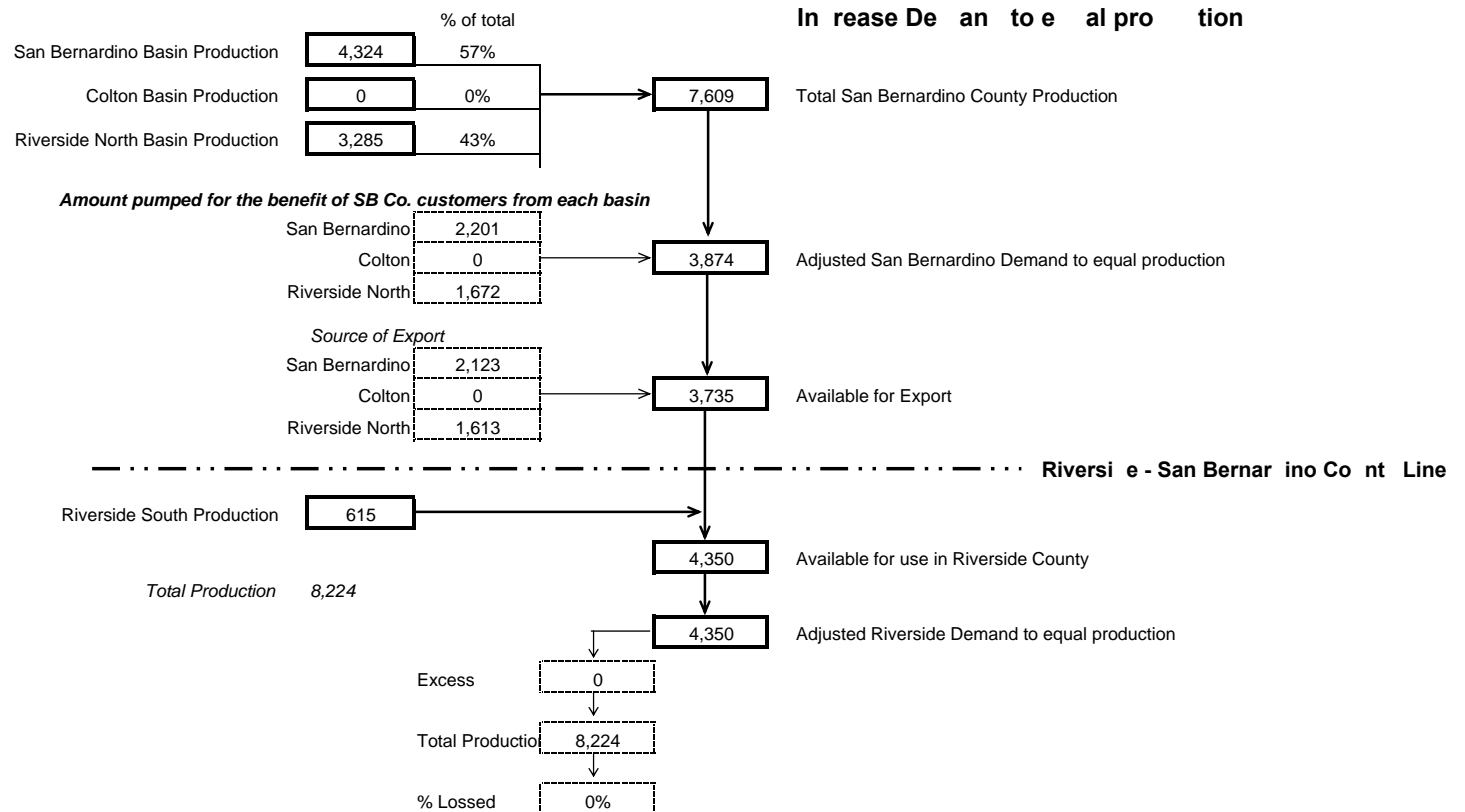
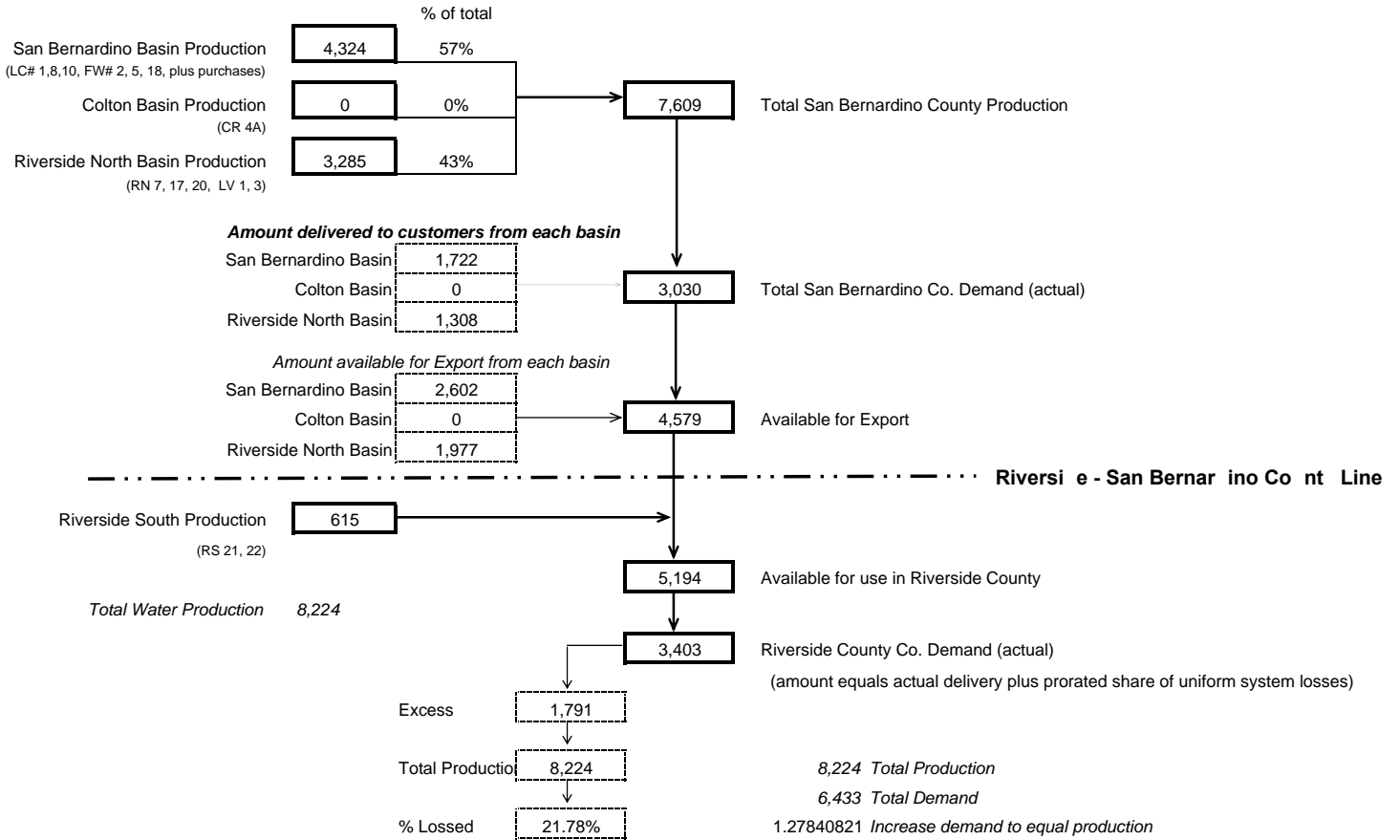
Dia ra B

Riversi e Hi lan Water Co pan 1993 Water S ppl Distrib tion



Dia ra B

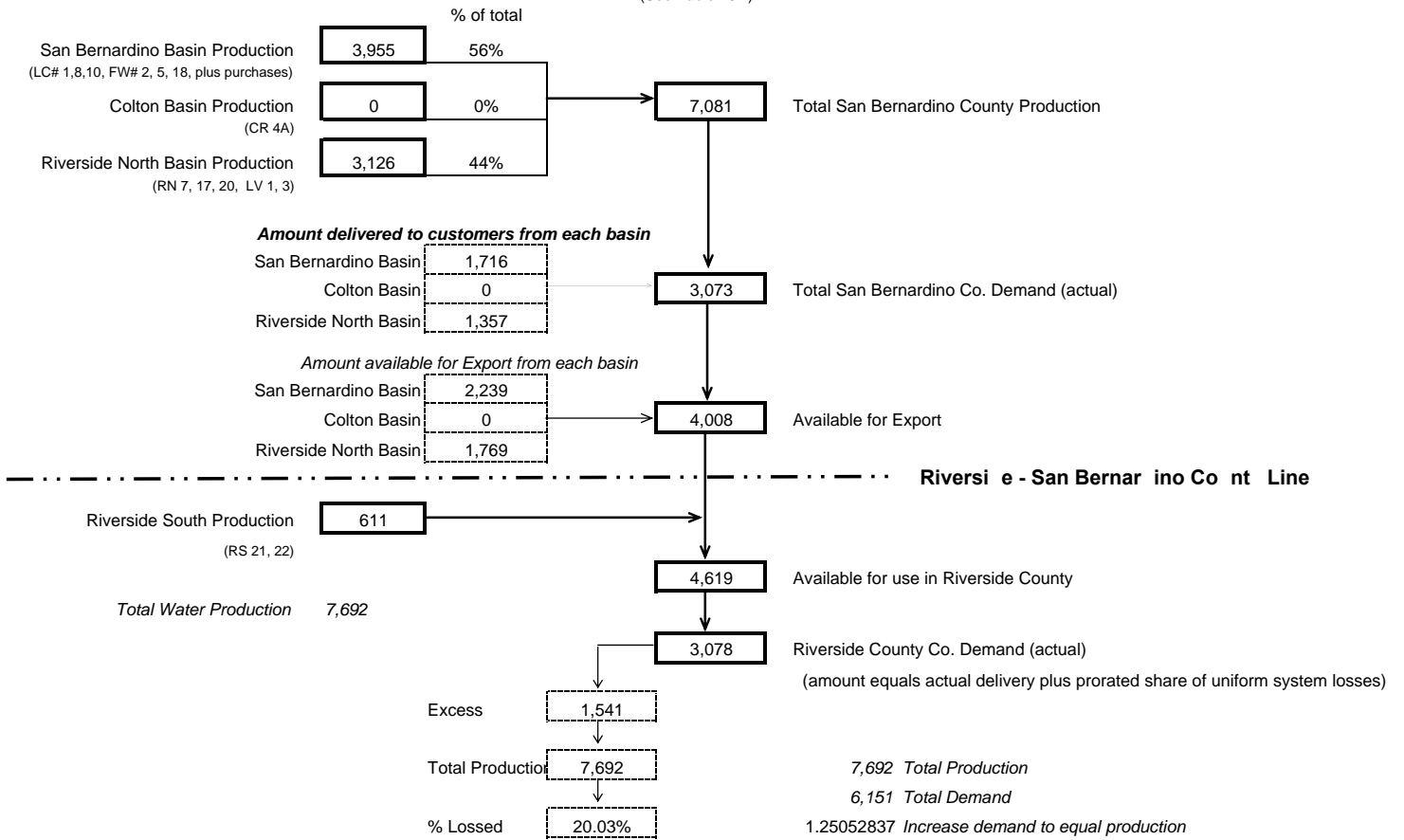
Riversi e Hi lan Water Co pan 1994 Water S ppl Distrib tion



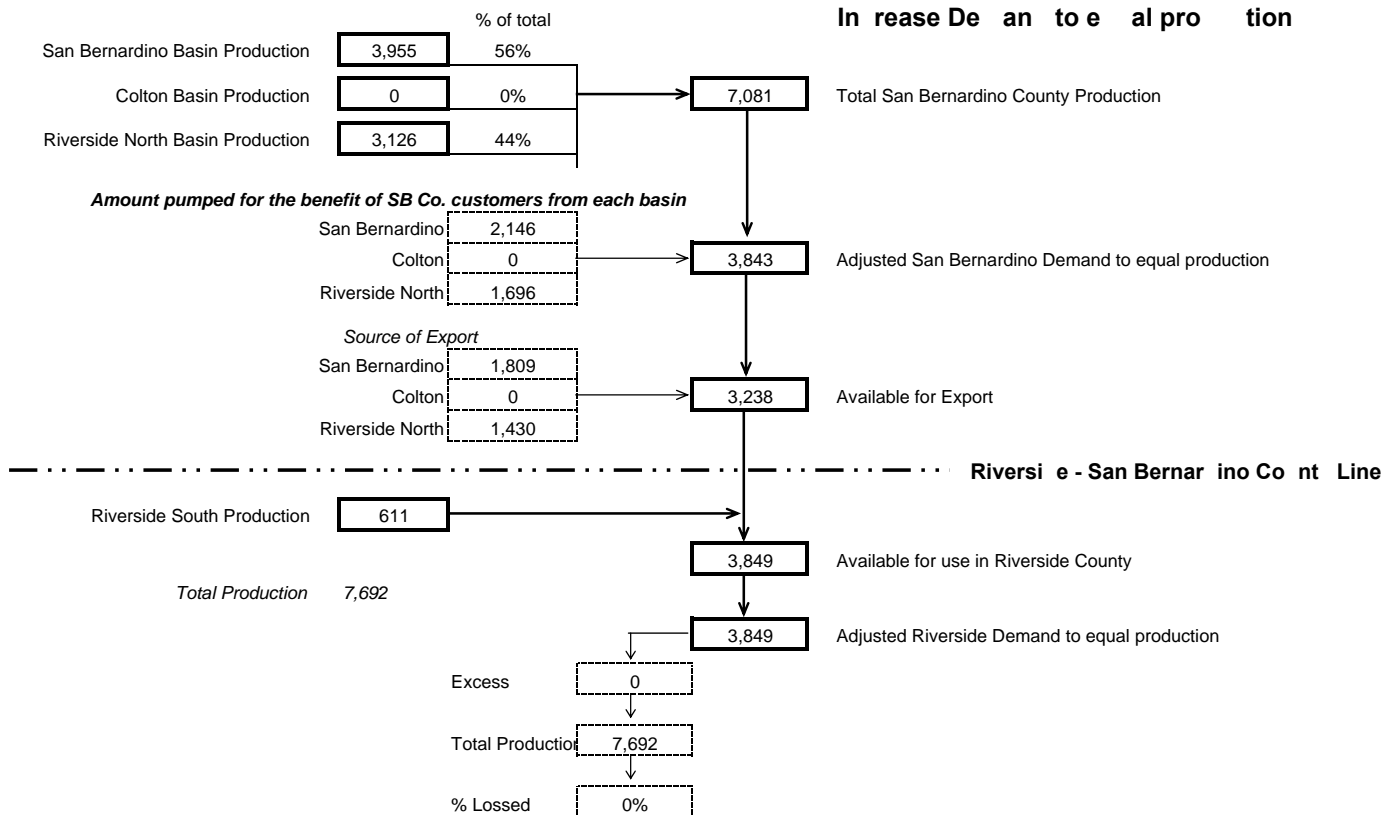
Dia ra B

Riverside Hi lan Water Co pan 1995 Water S ppl Distrib tion

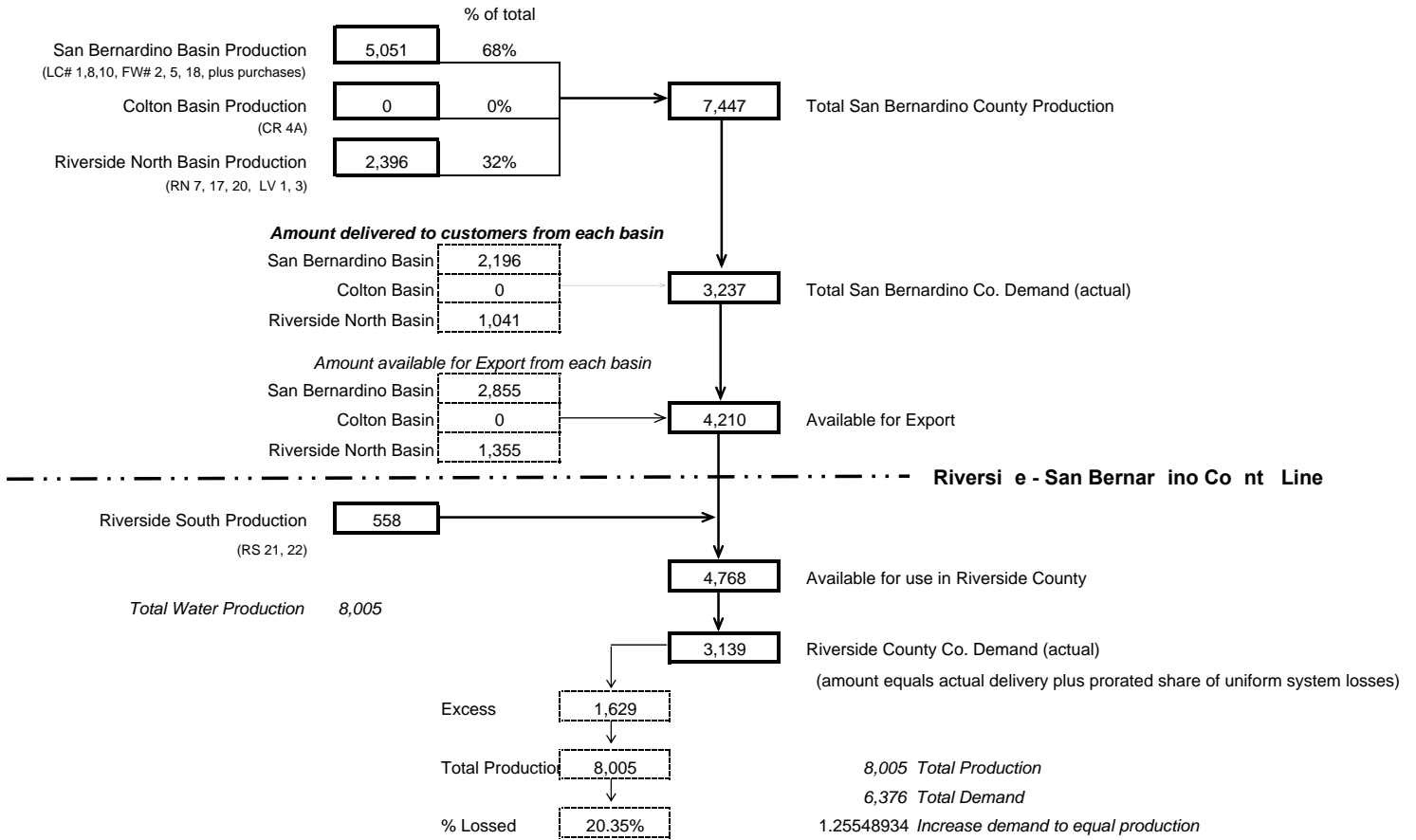
(See Table 23R)



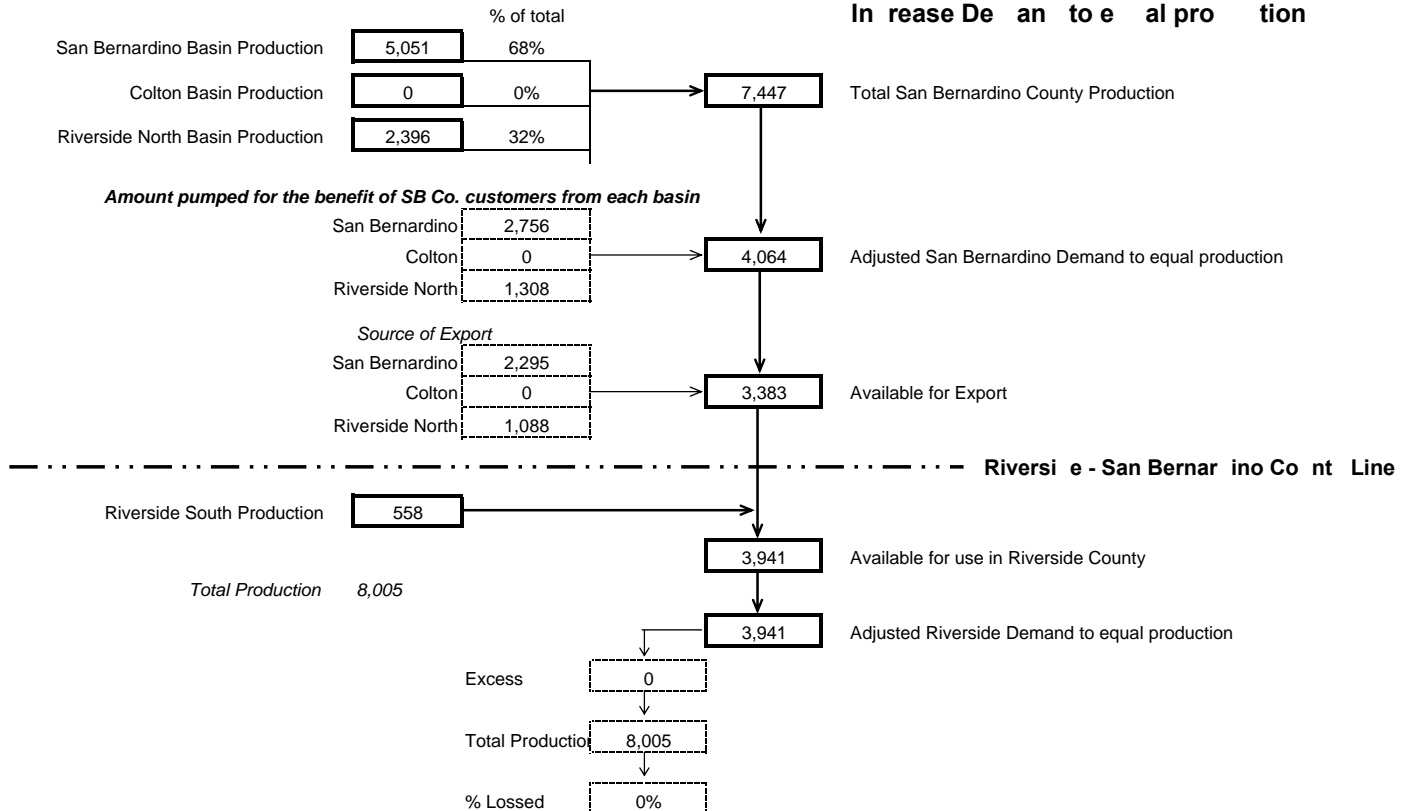
In rease De an to e al pro tion



Dia ra B Riversi e Hi lan Water Co pan 1996 Water S ppl Distrib tion

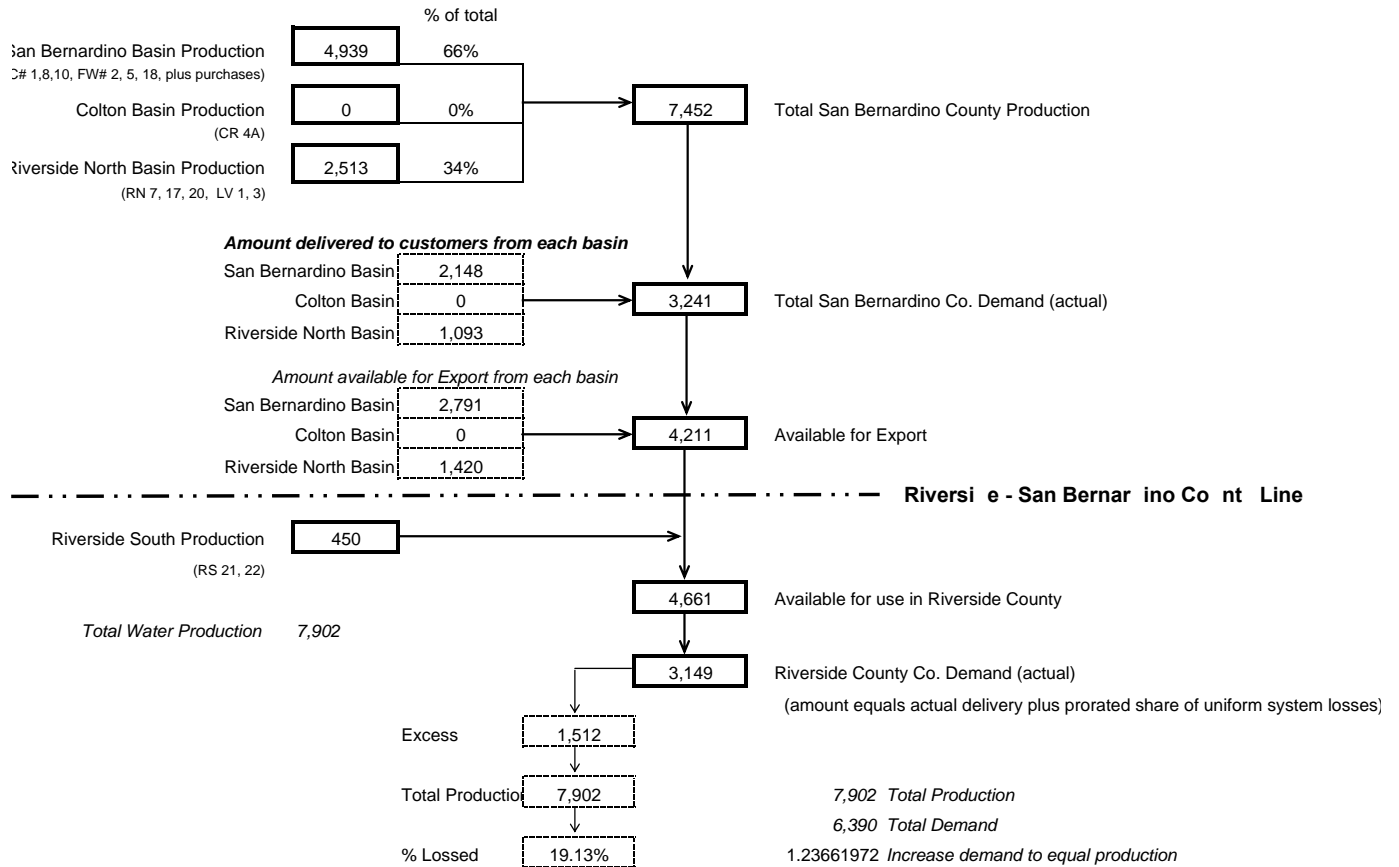


In rease De an to e al pro tion

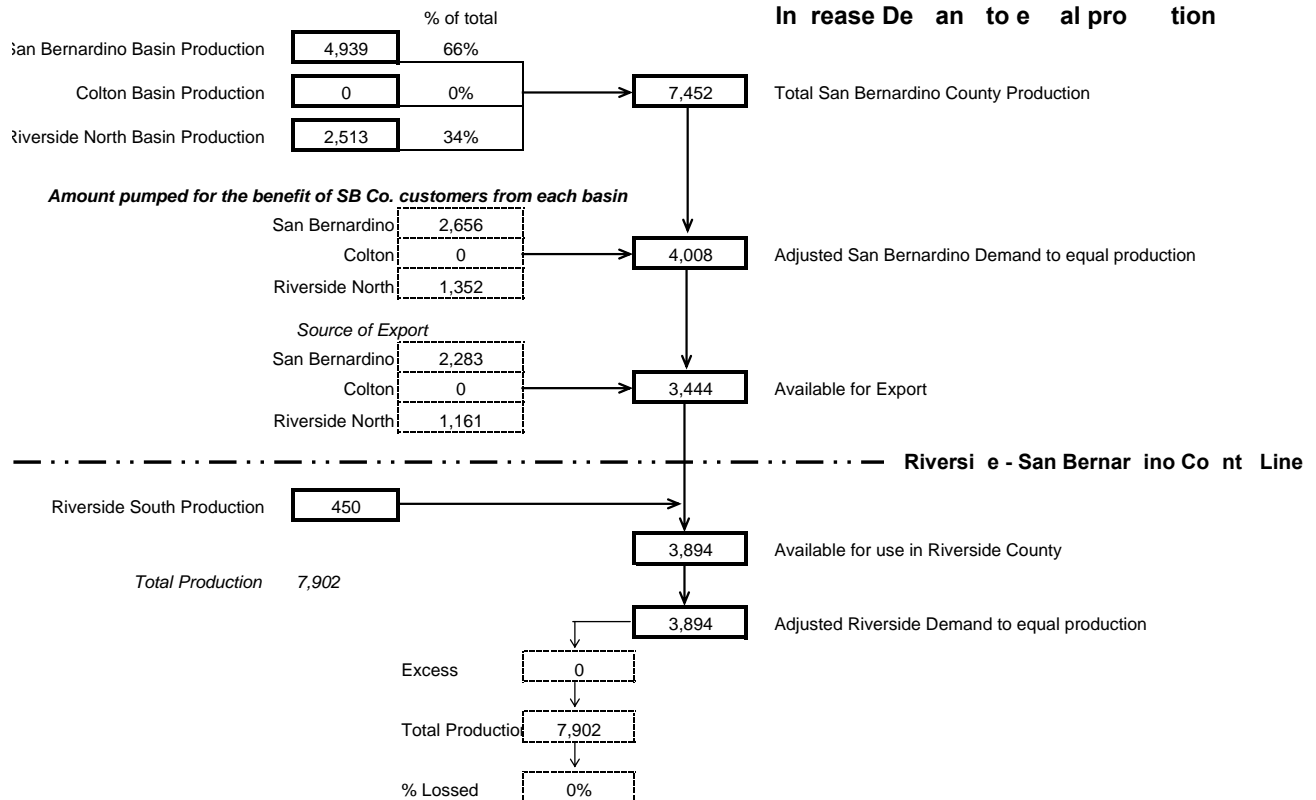


Dia ra B

Riverside Hills Water Company 1997 Water Supply Distribution

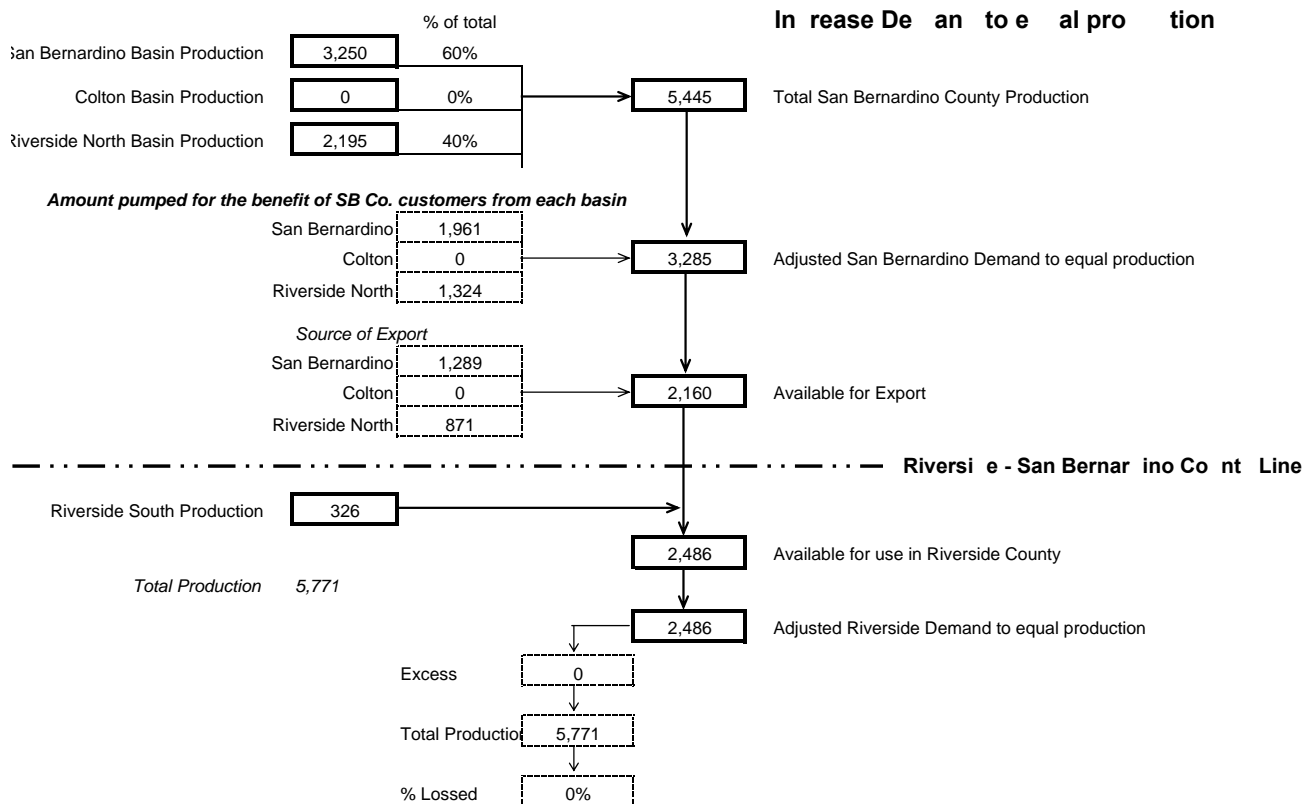
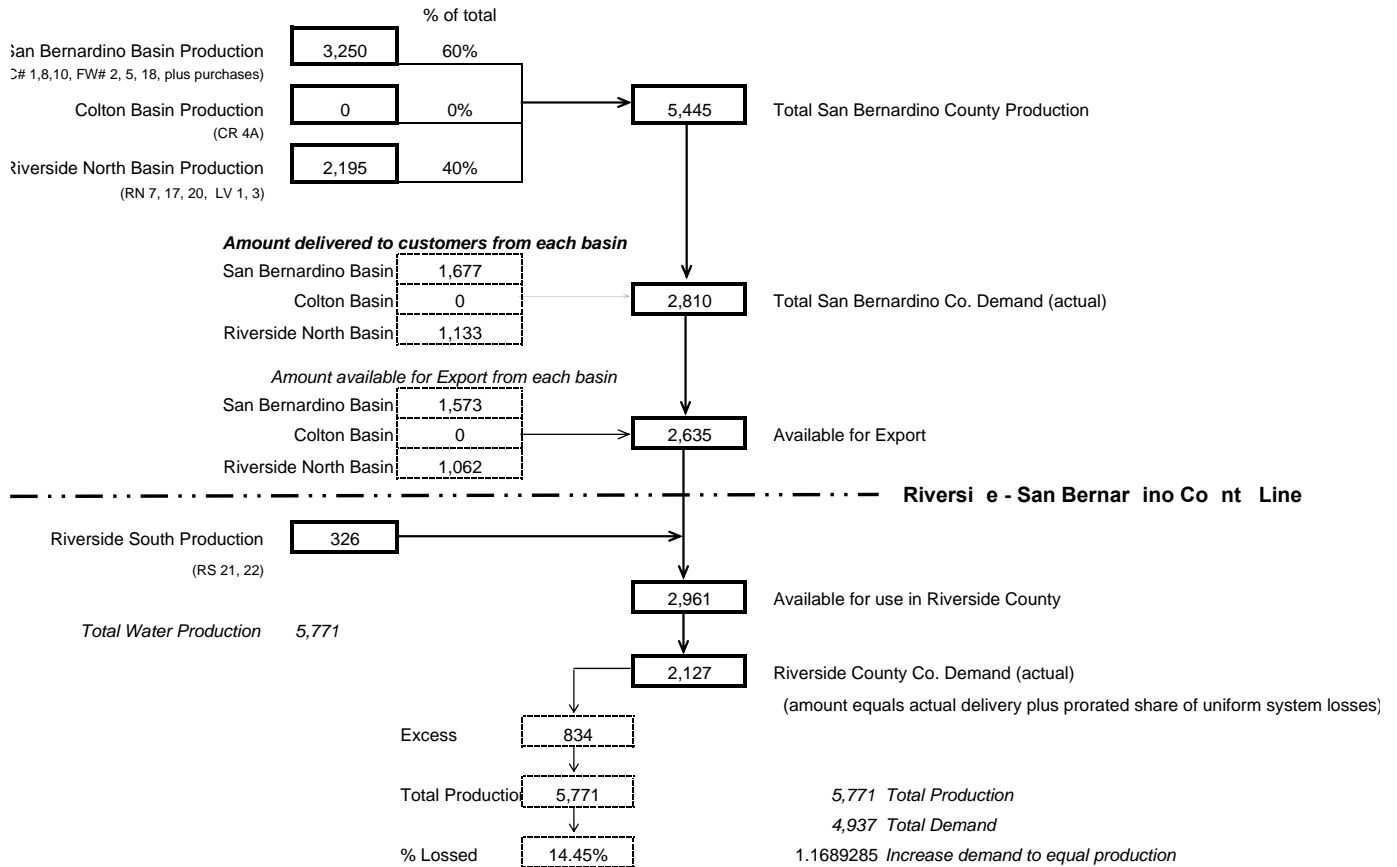


Increase Demand to Equal Production



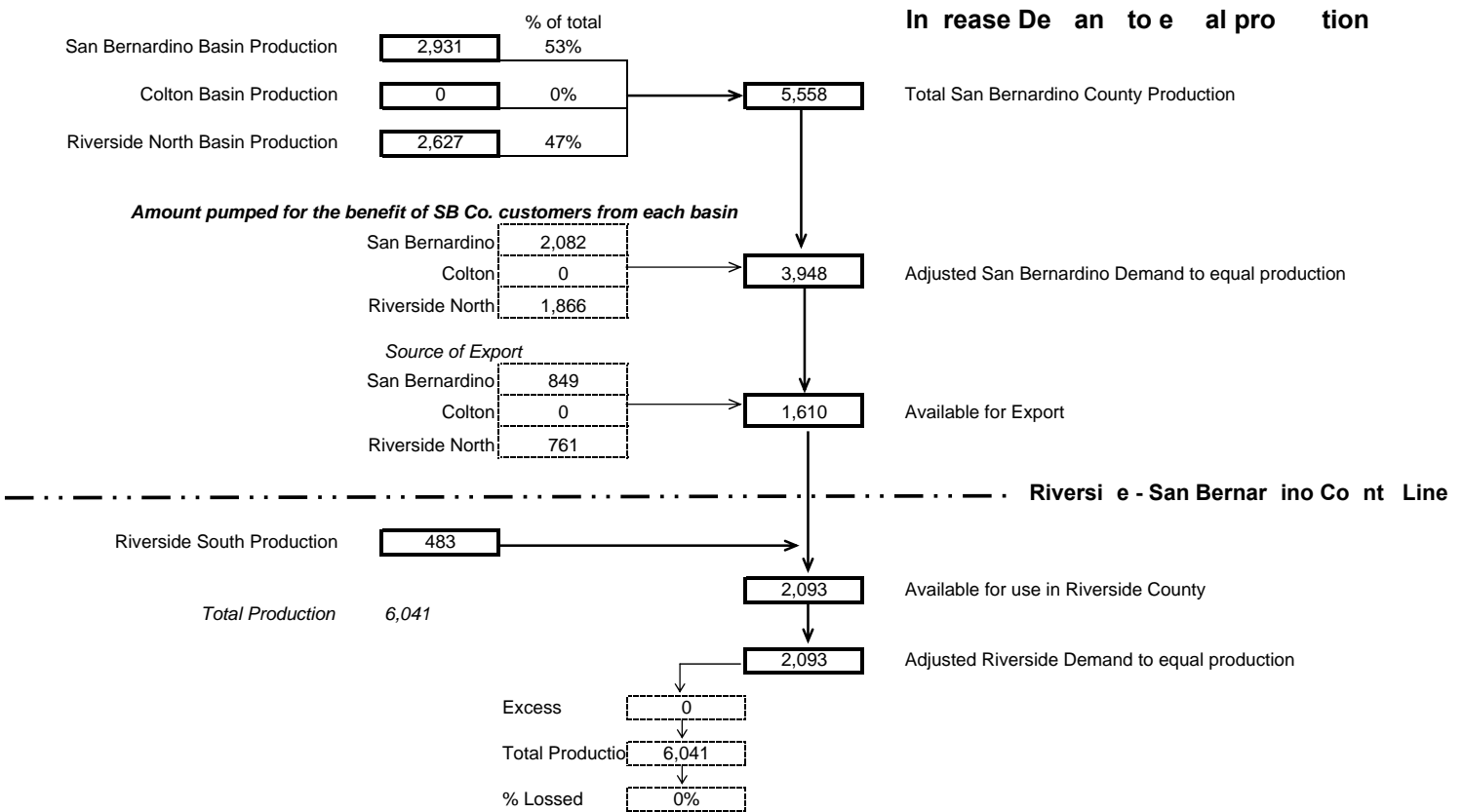
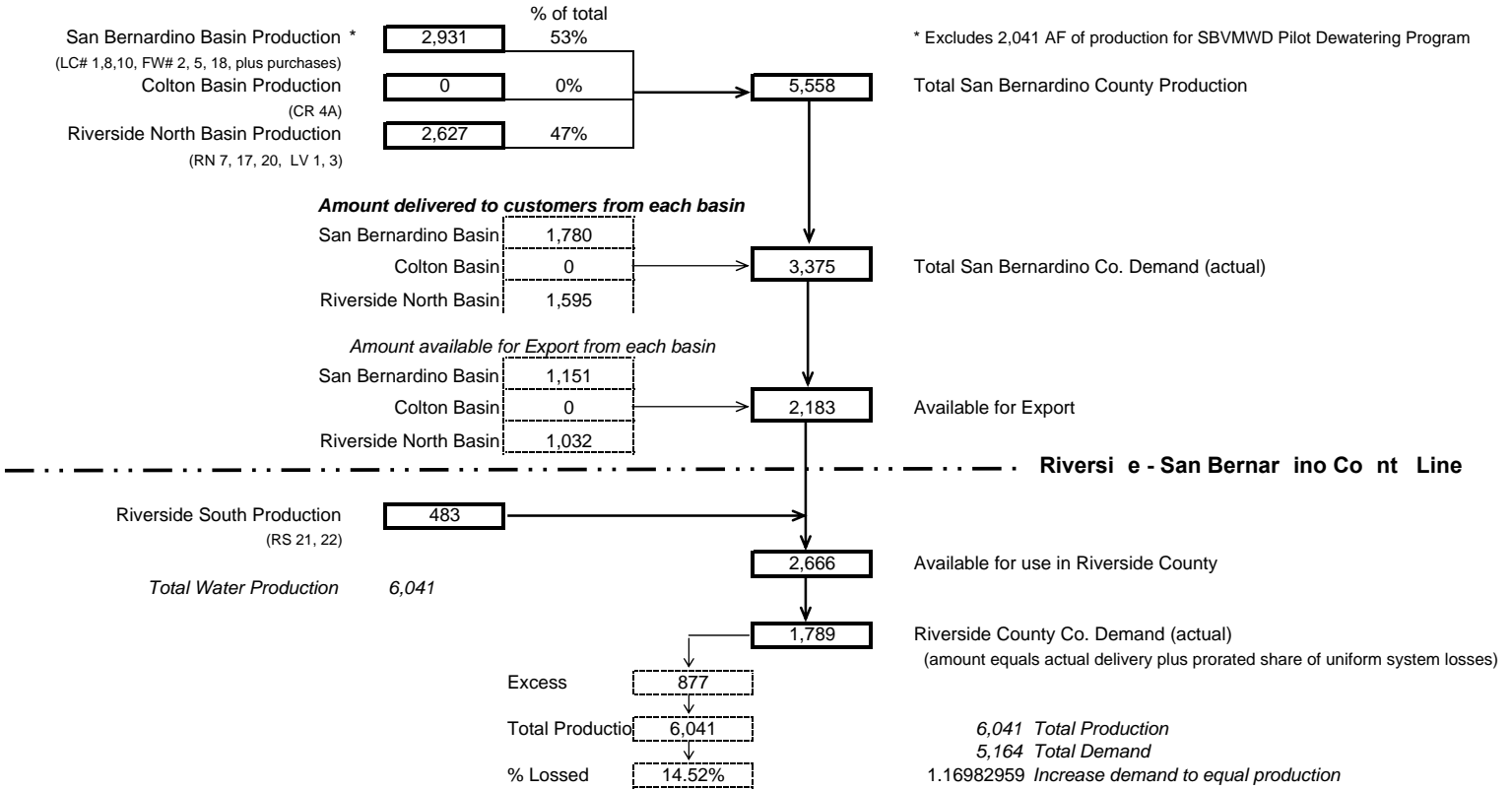
Dia ra B

Riverside Hi lan Water Co pan 1998 Water S ppl Distrib tion



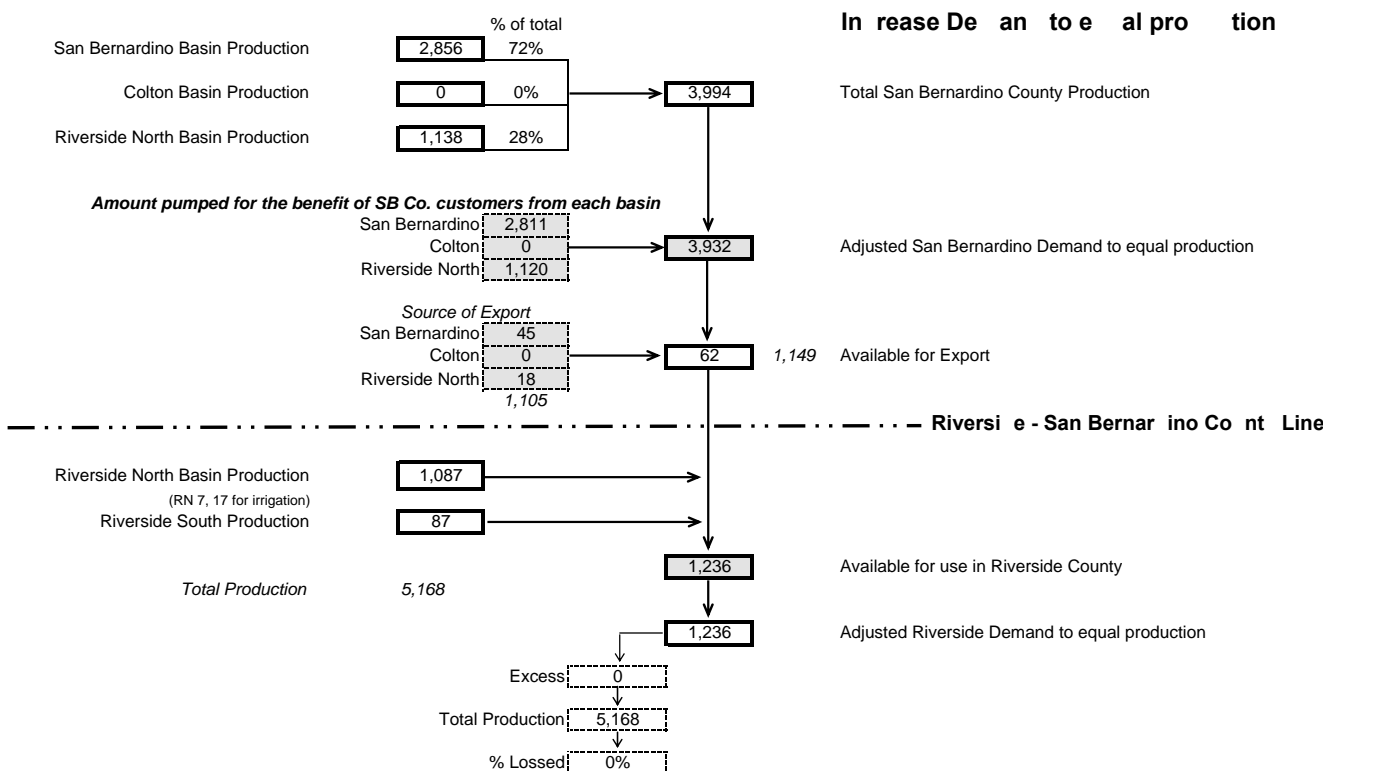
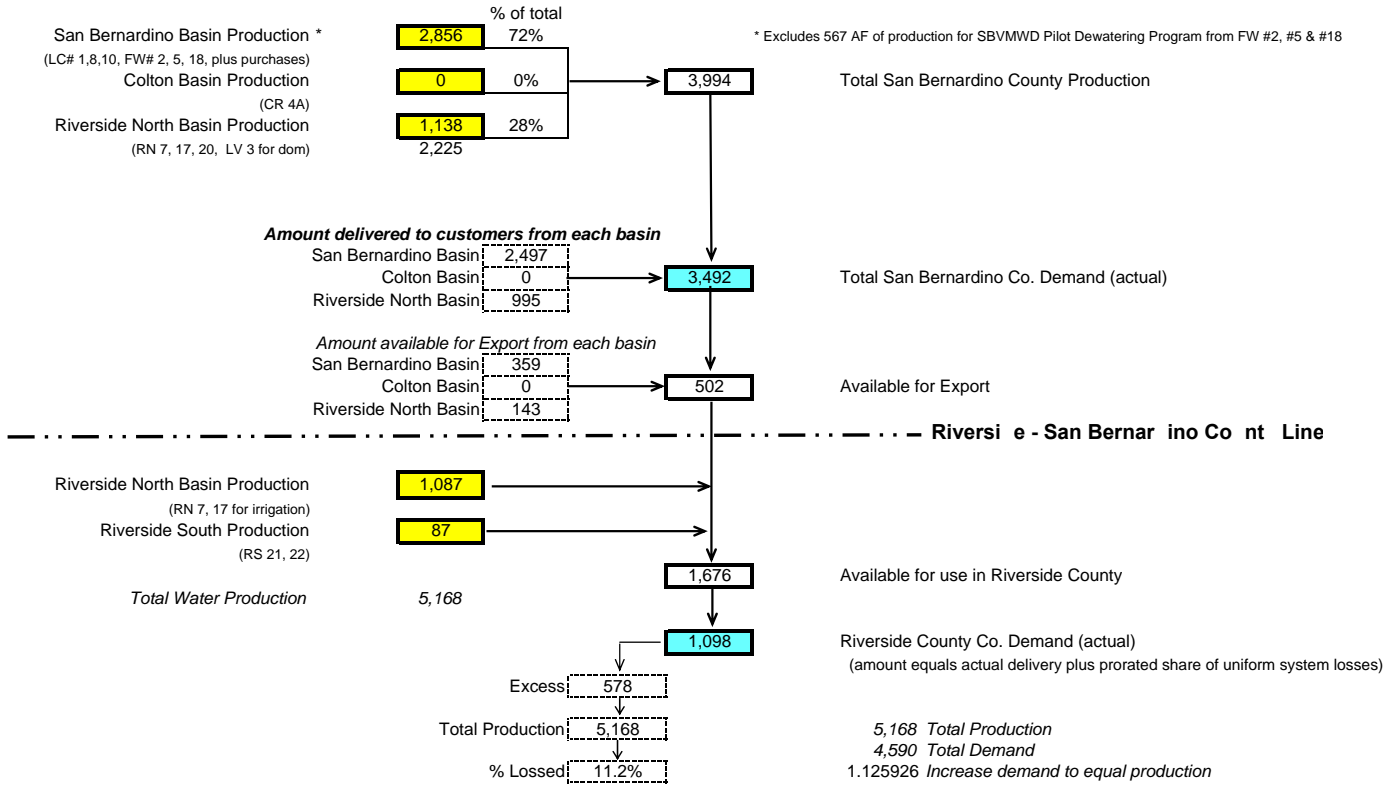
Dia ra B

Riverside Hi l an Water Co pan 1999 Water S ppl Distrib tion



Dia ra B

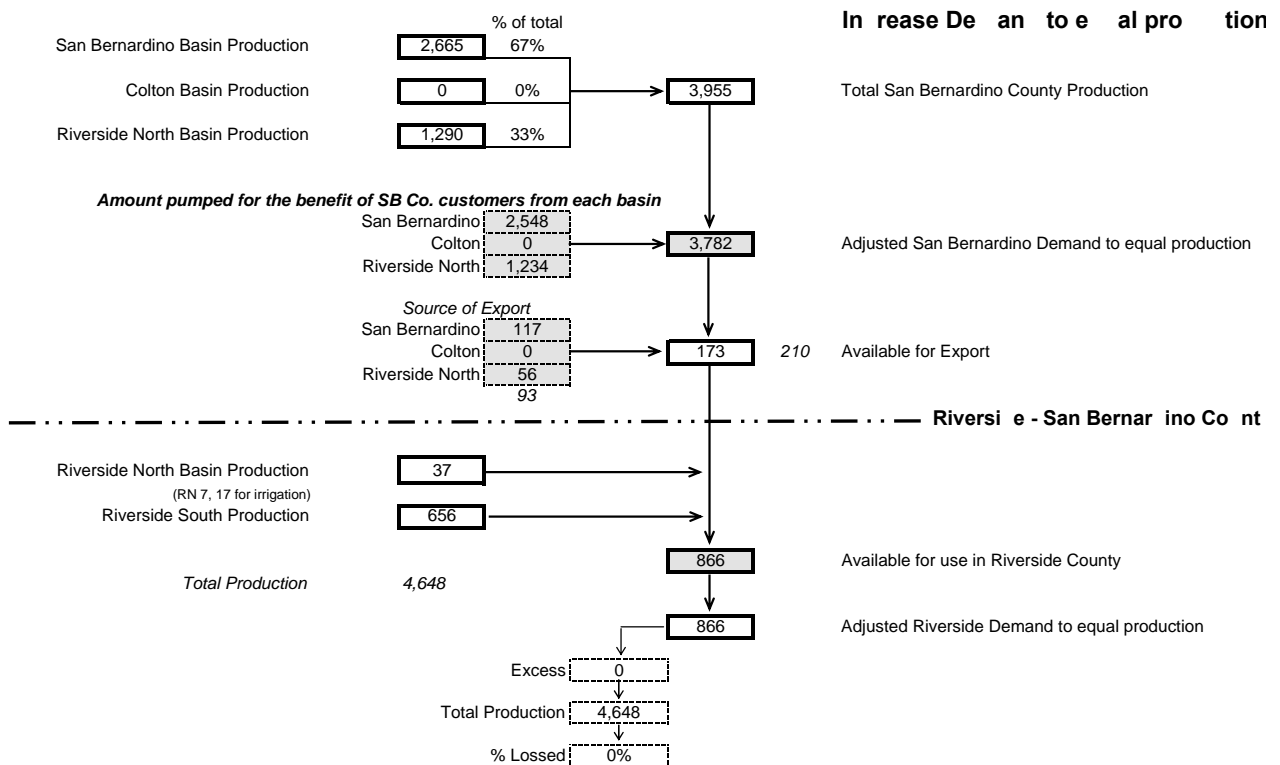
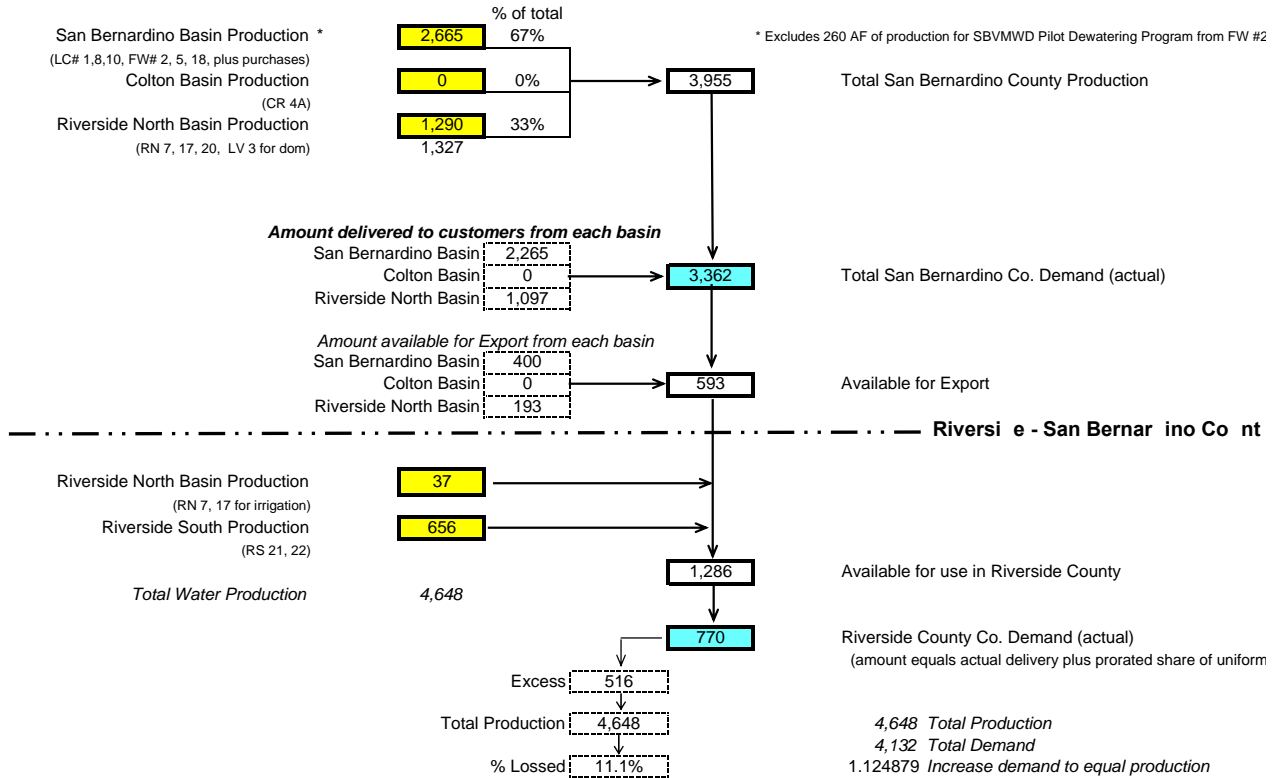
Riversi e Hi lan Water Co pan 2000 Water S ppl Distrib tion (revised 6/03)



Data from Watermaster Tables
 Data from Condensed Water Summary Report
 Values to check against calculated tables

Dia ra B

Riversi e Hi lan Water Co pan 2001 Water S ppl Distrib tion



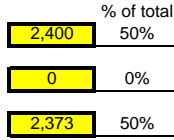
Data from Watermaster Tables
 Data from Condensed Water Summary Report
 Values to check against calculated tables

Dia ra B

Riversi e Hi lan Water Co pan 2002 Water S ppl Distrib tion

4340

San Bernardino Basin Production *
(LC# 1,8,10, FW# 2, 5, 18, plus purchases)
Colton Basin Production
(CR 4A)
Riverside North Basin Production
(RN 6, 7, 17, 20, LV 3 for dom)

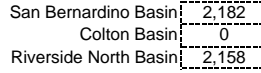


* Excludes 1,909 AF of production for SBVMWD Pilot Dewatering Program from FW #2, #5 & #18

4,773

Total San Bernardino County Production

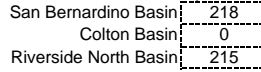
Amount delivered to customers from each basin



4,340

Total San Bernardino Co. Demand (actual)

Amount available for Export from each basin



433

Available for Export

Riversi e - San Bernar ino Co nt Line

Riverside North Basin Production
(RN 7, 17 for irrigation)
Riverside South Production
(RS 21, 22)



1,251

Available for use in Riverside County

Total Water Production

5,591

998

Riverside County Co. Demand (actual)
(amount equals actual delivery plus prorated share of uniform system losses)

Excess: 253

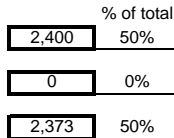
Total Production: 5,591

% Lossed: 4.5%

5,591 Total Production
5,338 Total Demand
1.047396 Increase demand to equal production

In rease De an to e al pro tion

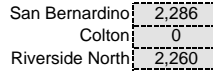
San Bernardino Basin Production
Colton Basin Production
Riverside North Basin Production



4,773

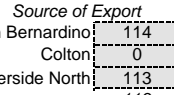
Total San Bernardino County Production

Amount pumped for the benefit of SB Co. customers from each basin



4,546

Adjusted San Bernardino Demand to equal production



227

227 Available for Export

Riversi e - San Bernar ino Co nt Line

Riverside North Basin Production
(RN 7, 17 for irrigation)
Riverside South Production



1,045

Available for use in Riverside County

Total Production

5,591

1,045

Adjusted Riverside Demand to equal production

Excess: 0

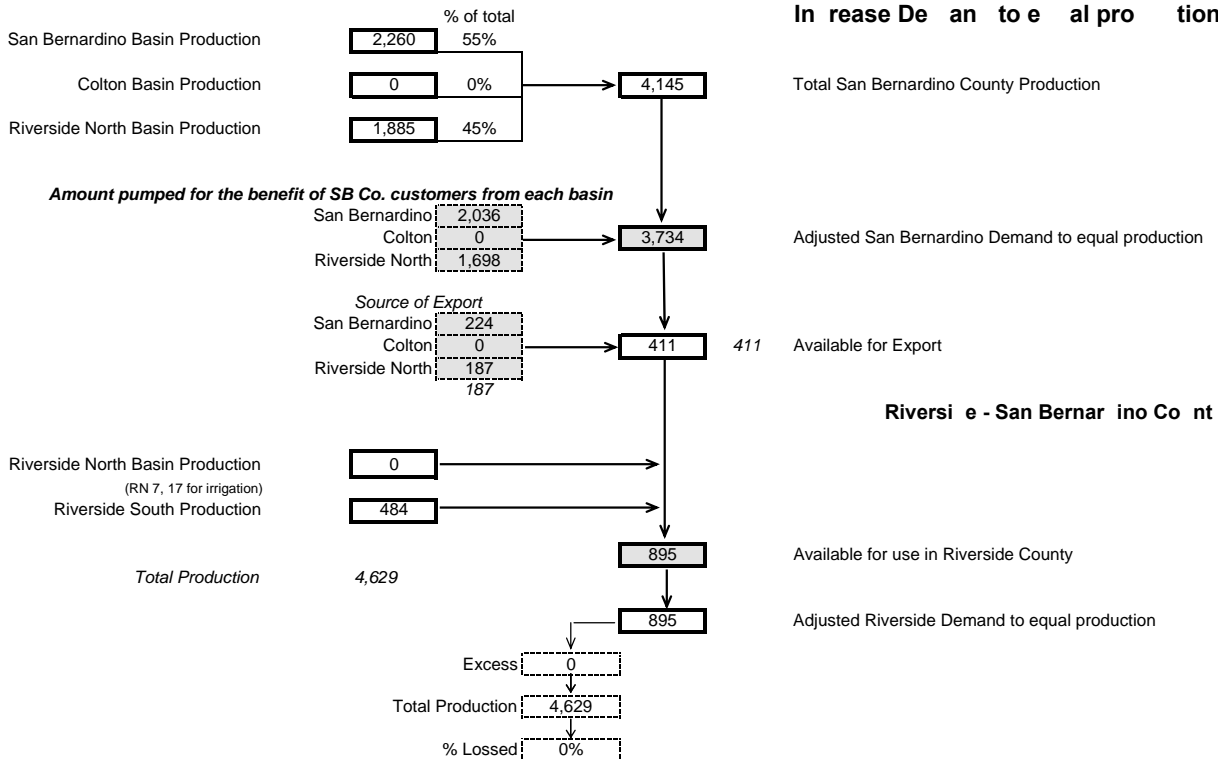
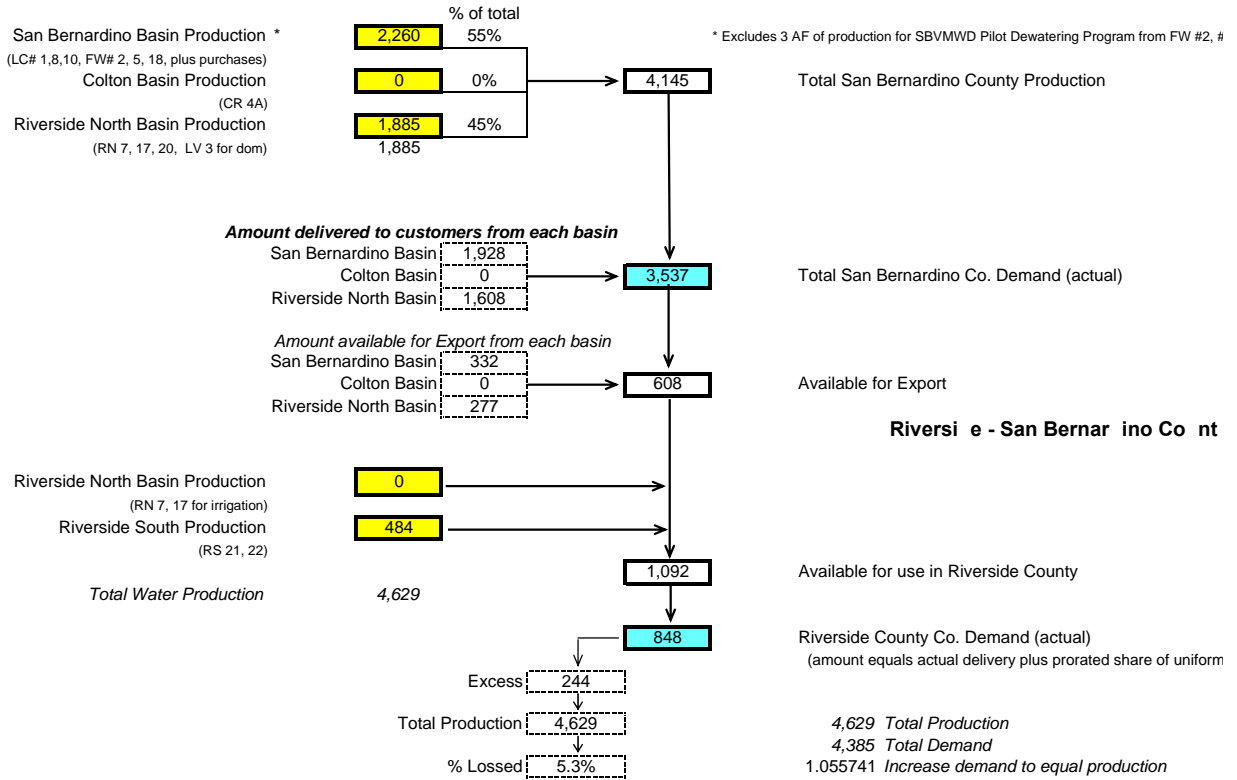
Total Production: 5,591

% Lossed: 0%

Data from Watermaster Tables
 Data from Condensed Water Summary Report
 Values to check against calculated tables

Dia ra B

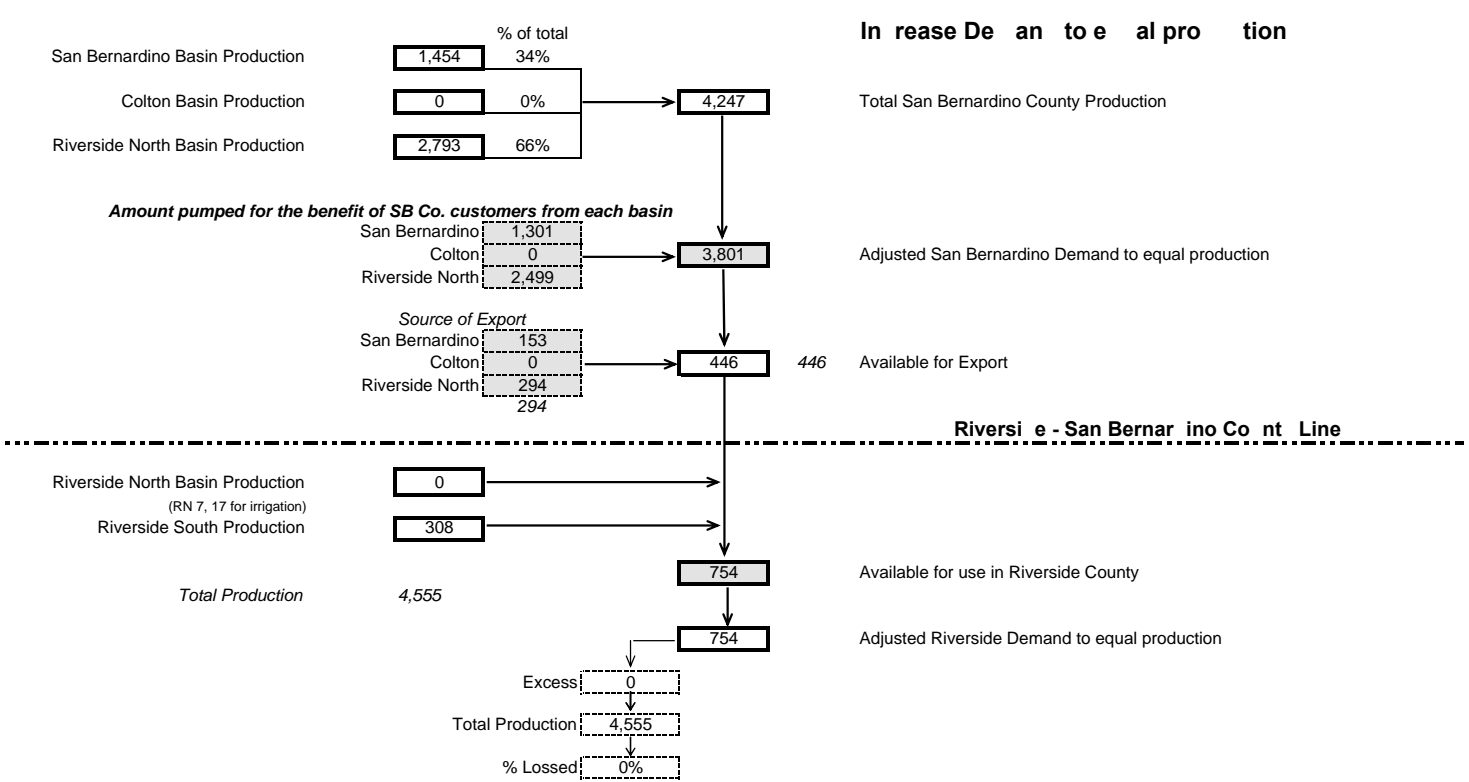
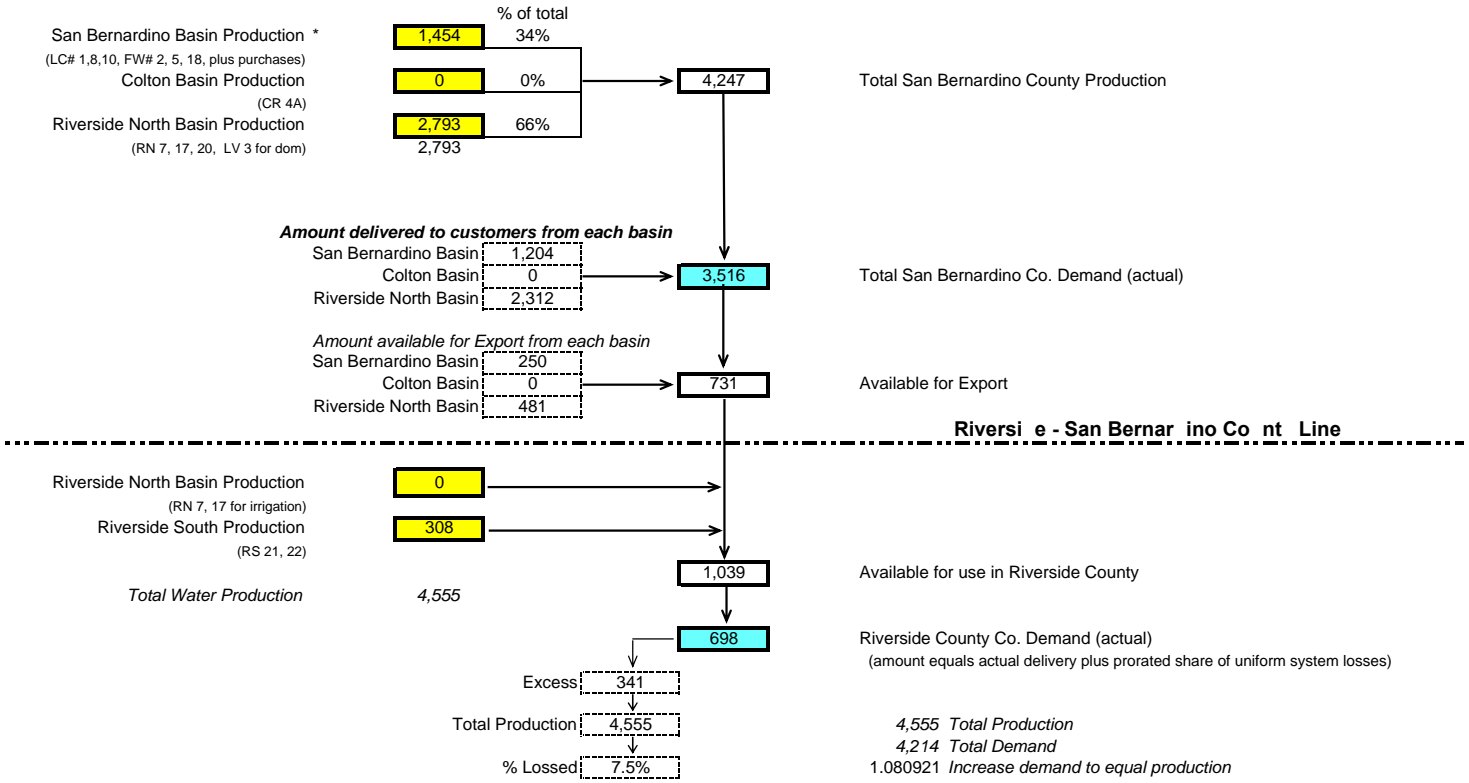
Riversi e Hi lan Water Co pan 2003 Water S ppl Distrib tion



Data from Watermaster Tables
 Data from Condensed Water Summary Report
 Values to check against calculated tables

Dia ra B

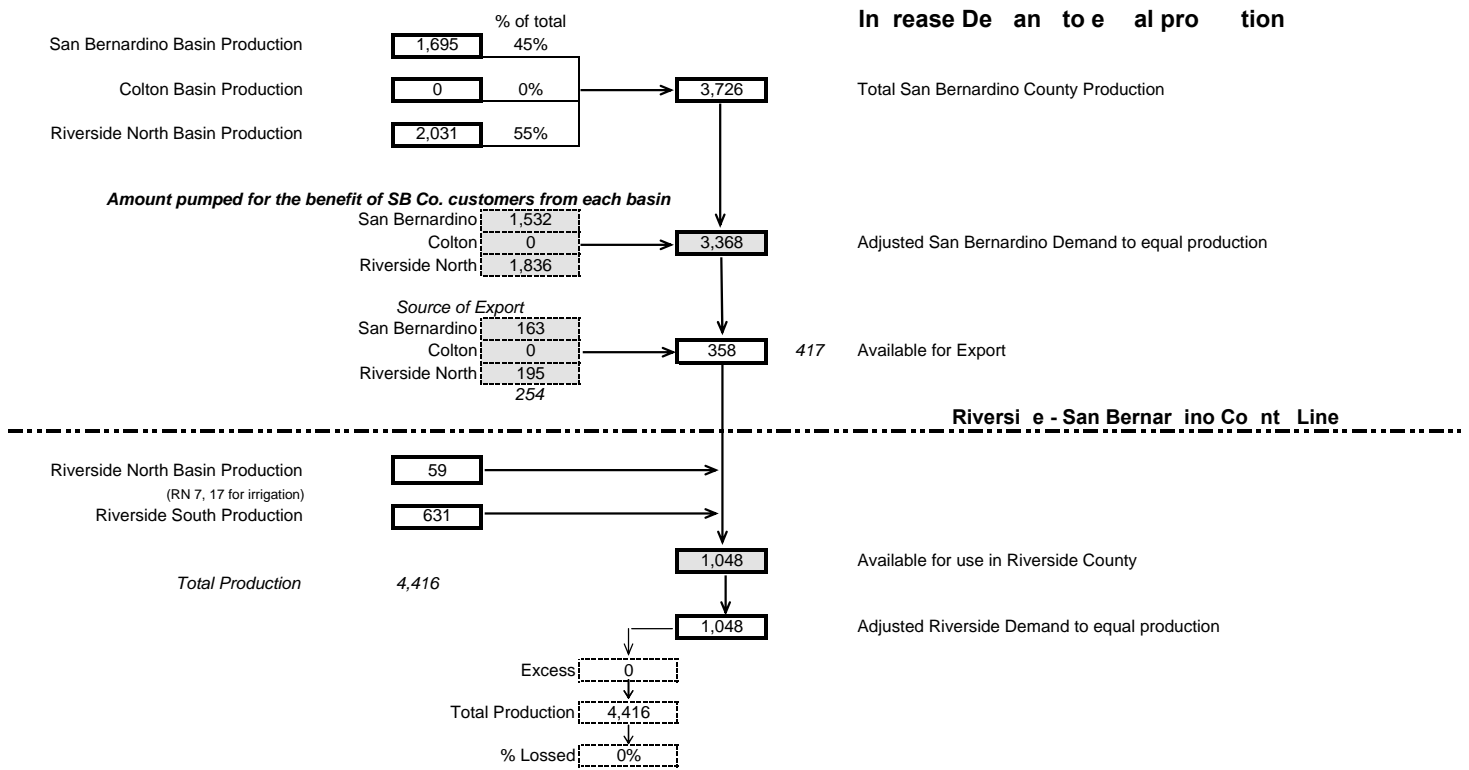
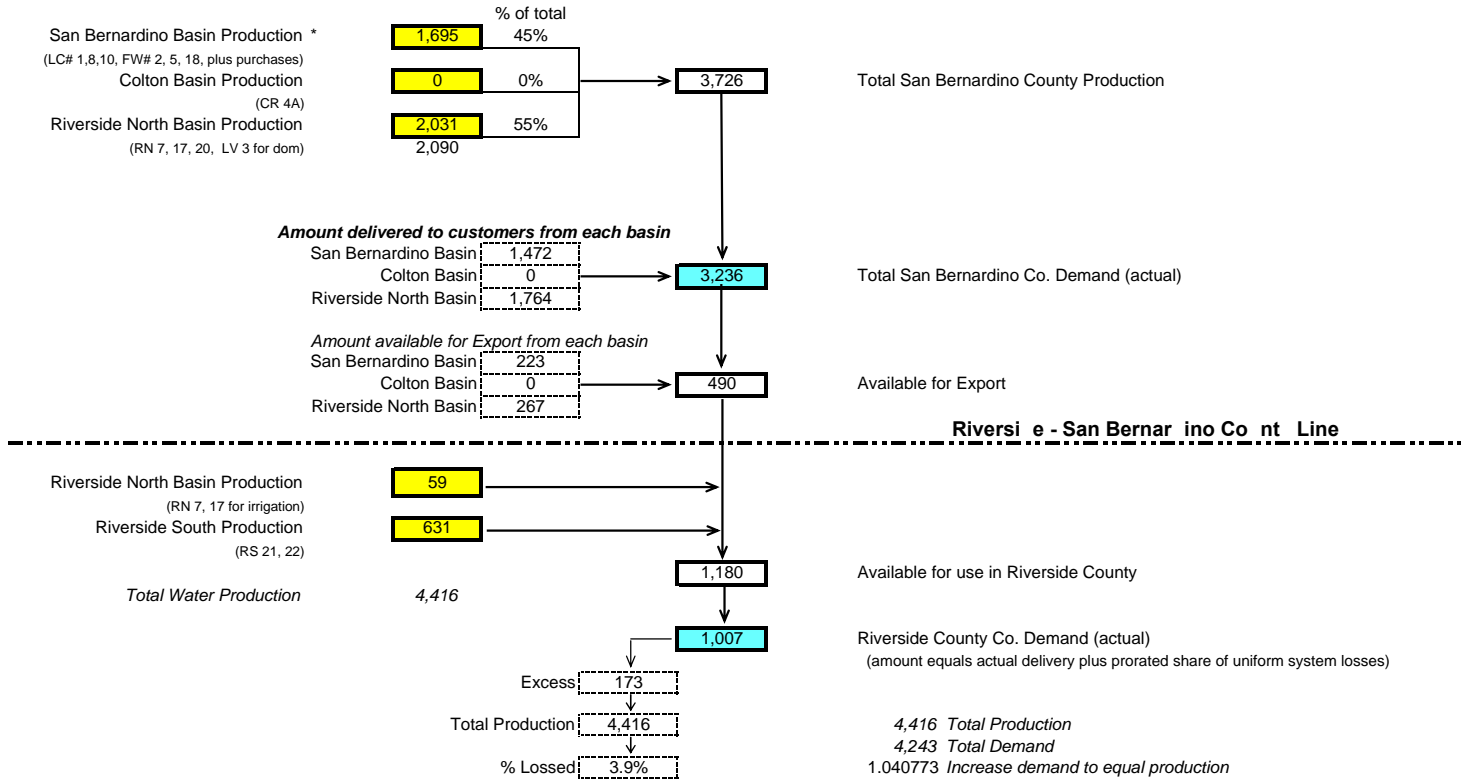
Riversi e Hi lan Water Co pan 2004 Water S ppl Distrib tion



 Data from Watermaster Tables
 Data from Condensed Water Summary Report
 Values to check against calculated tables

Dia ra B

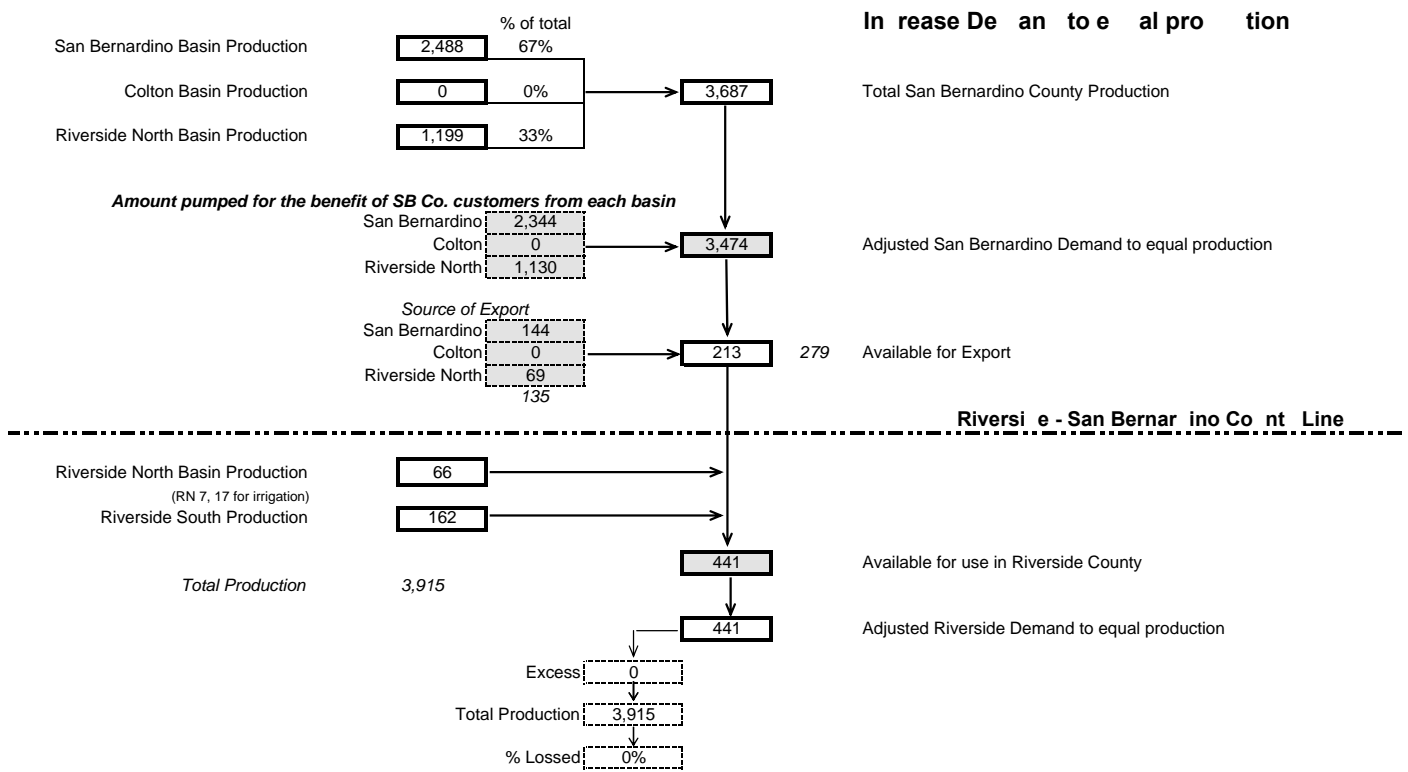
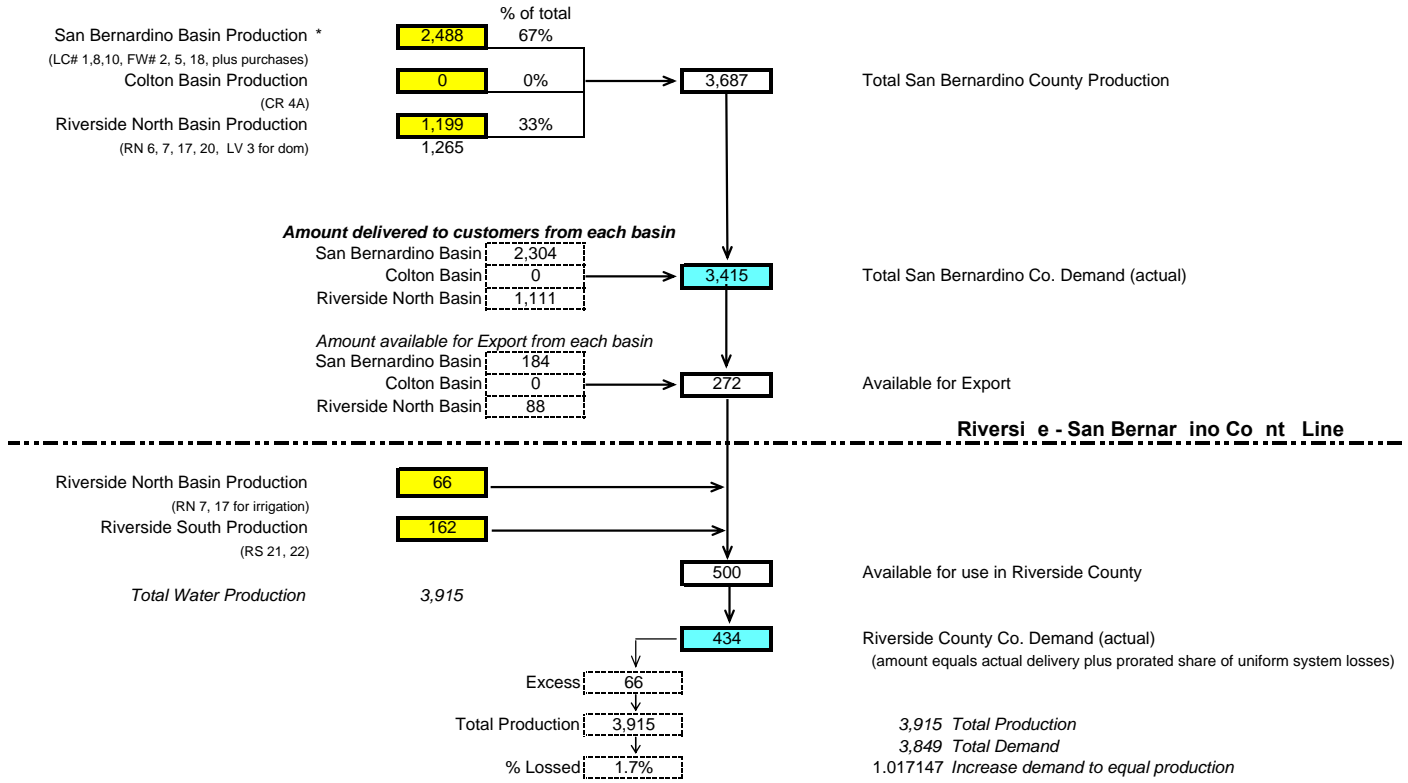
Riversi e Hi lan Water Co pan 2005 Water S ppl Distrib tion



Data from Watermaster Tables
 Data from Condensed Water Summary Report
 Values to check against calculated tables

Dia ra B

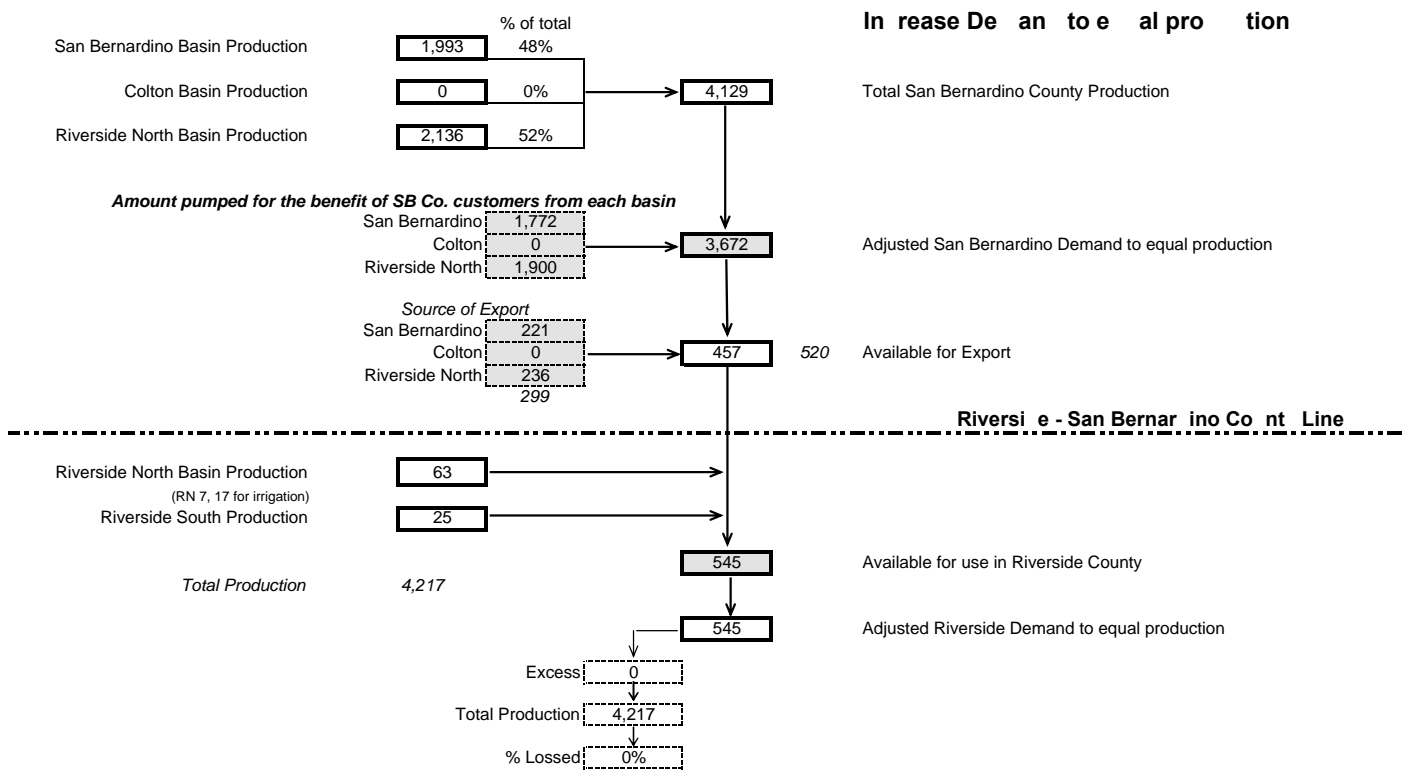
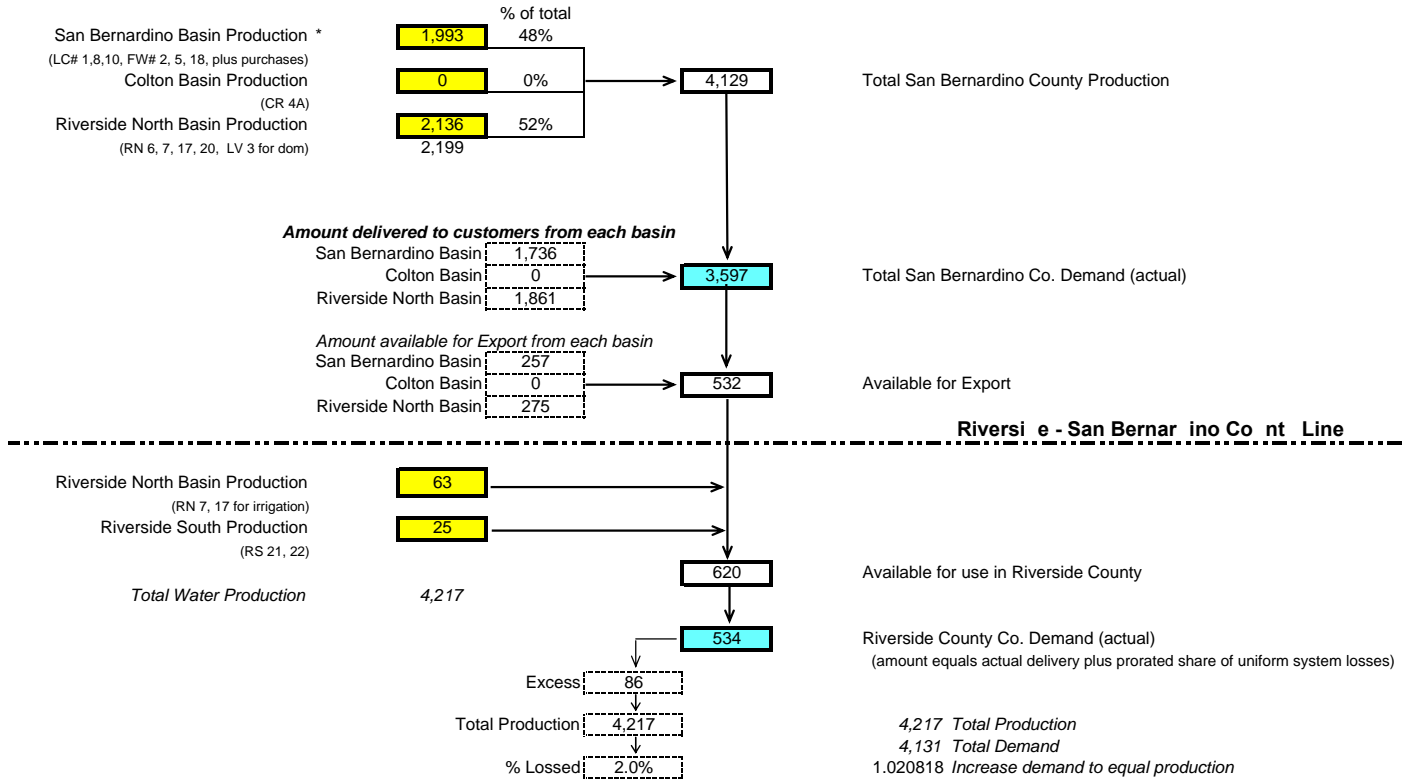
Riversi e Hi lan Water Co pan 2006 Water S ppl Distrib tion



 Data from Watermaster Tables
 Data from Condensed Water Summary Report
 Values to check against calculated tables

Dia ra B

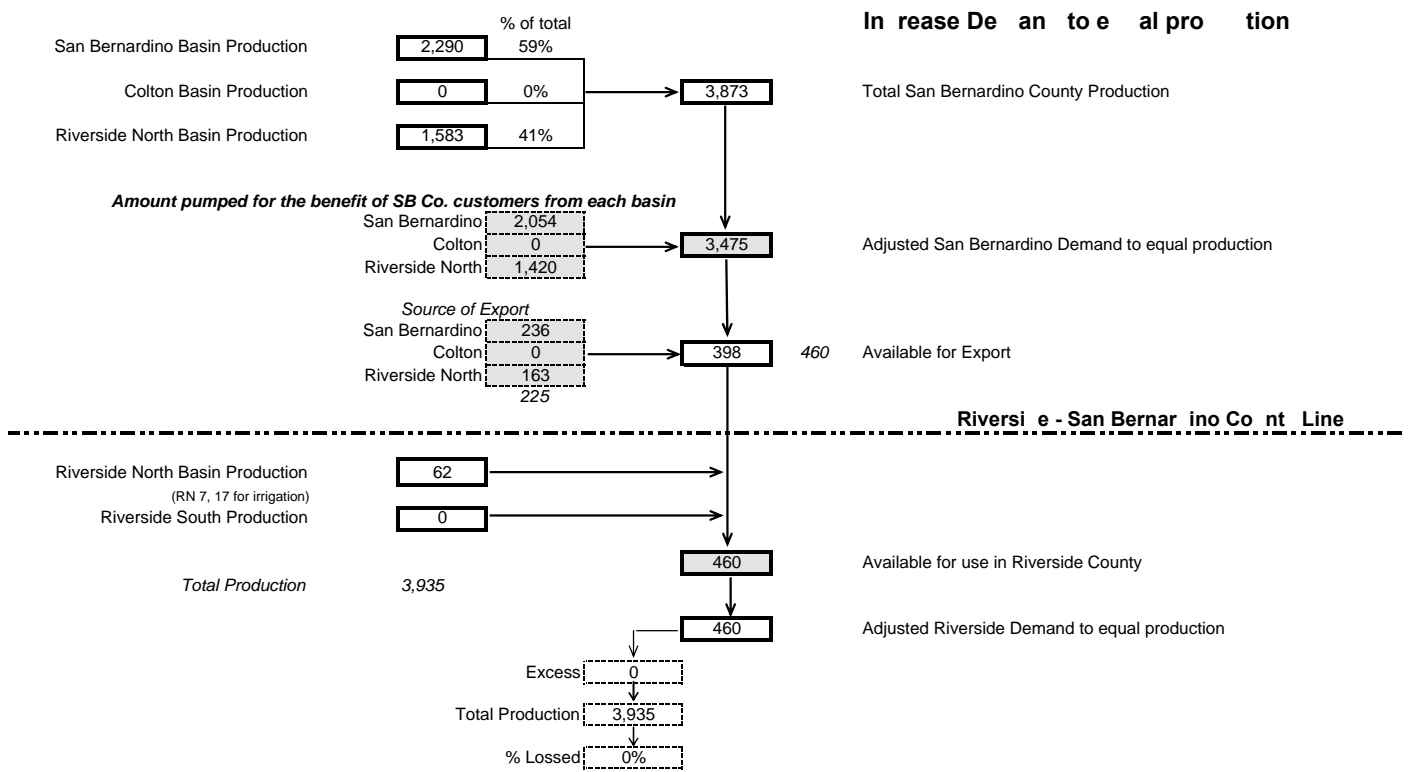
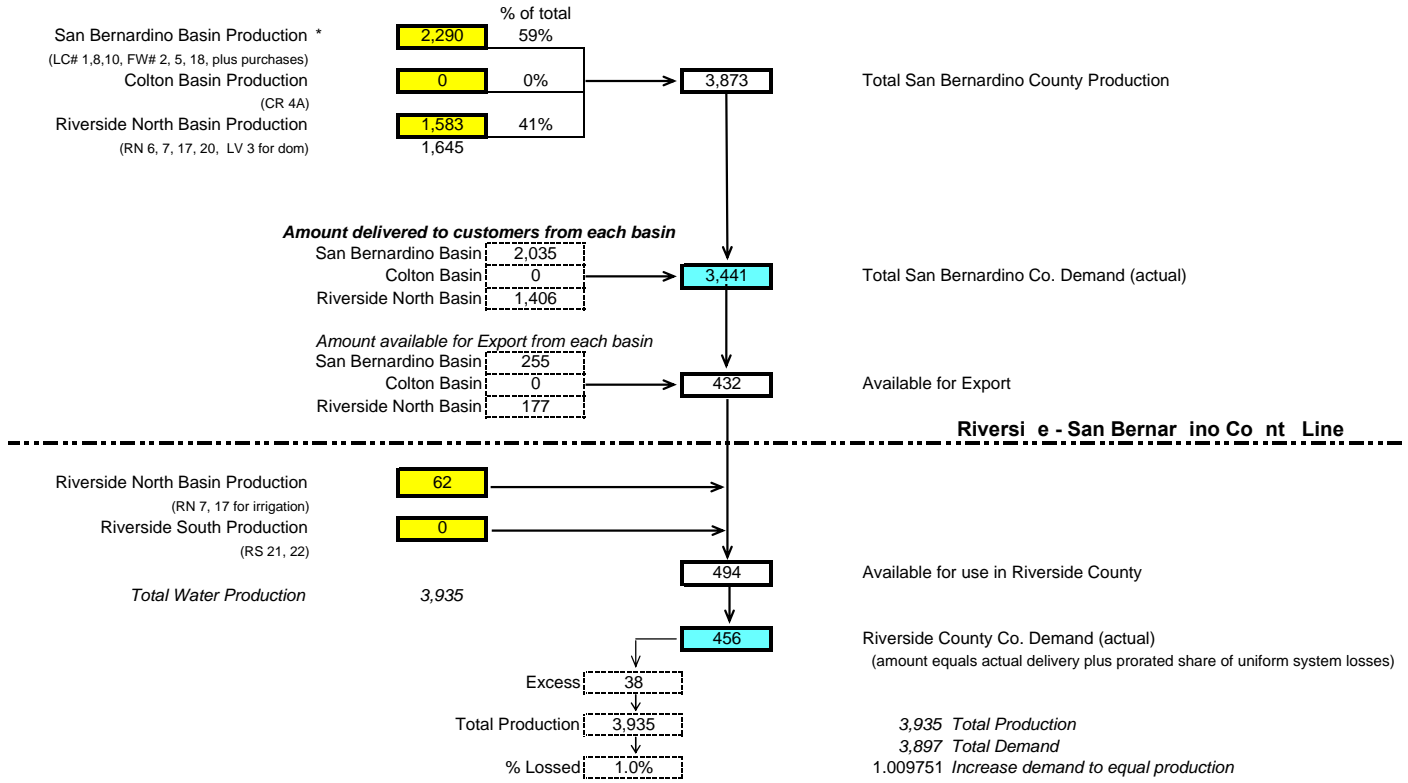
Riverside Hi lan Water Co pan 2007 Water S ppl Distrib tion



Data from Watermaster Tables
 Data from Condensed Water Summary Report
 Values to check against calculated tables

Dia ra B

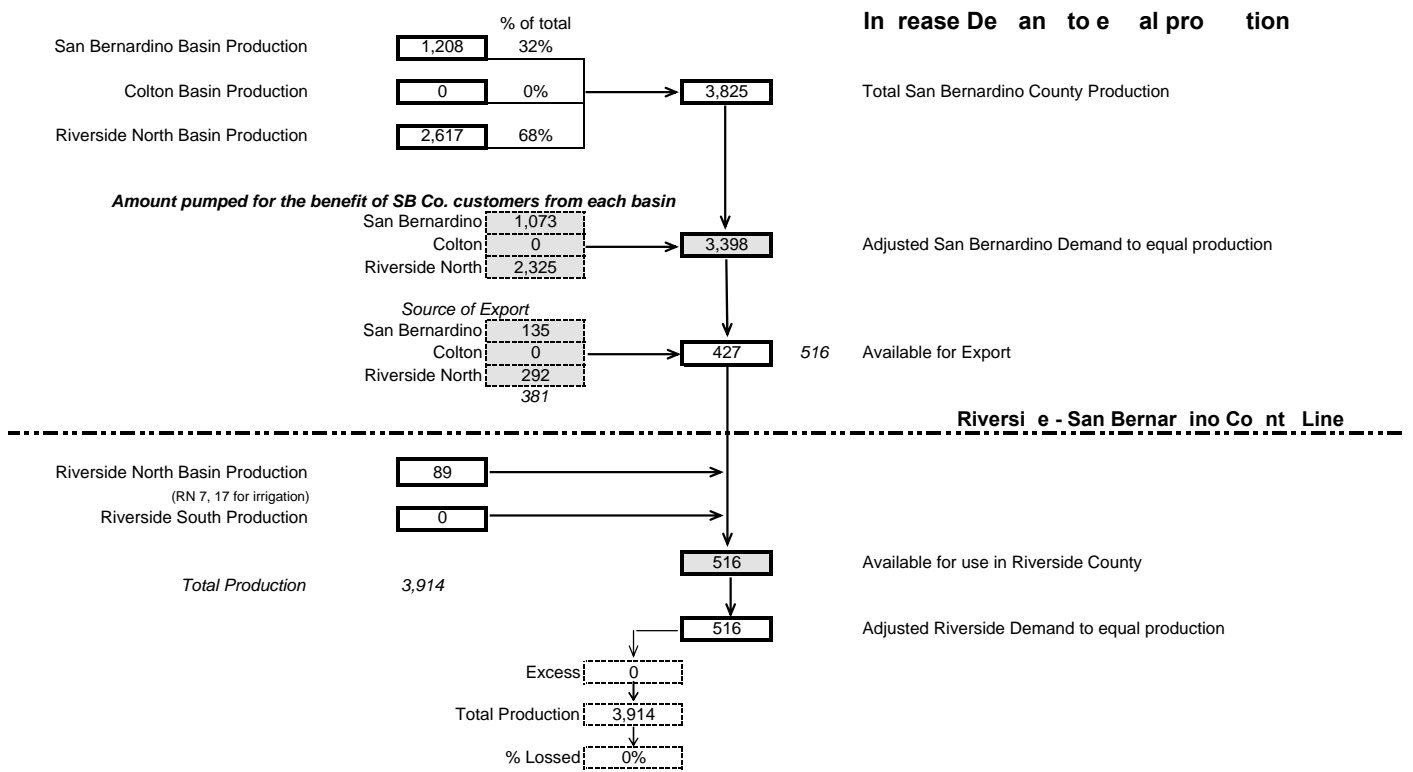
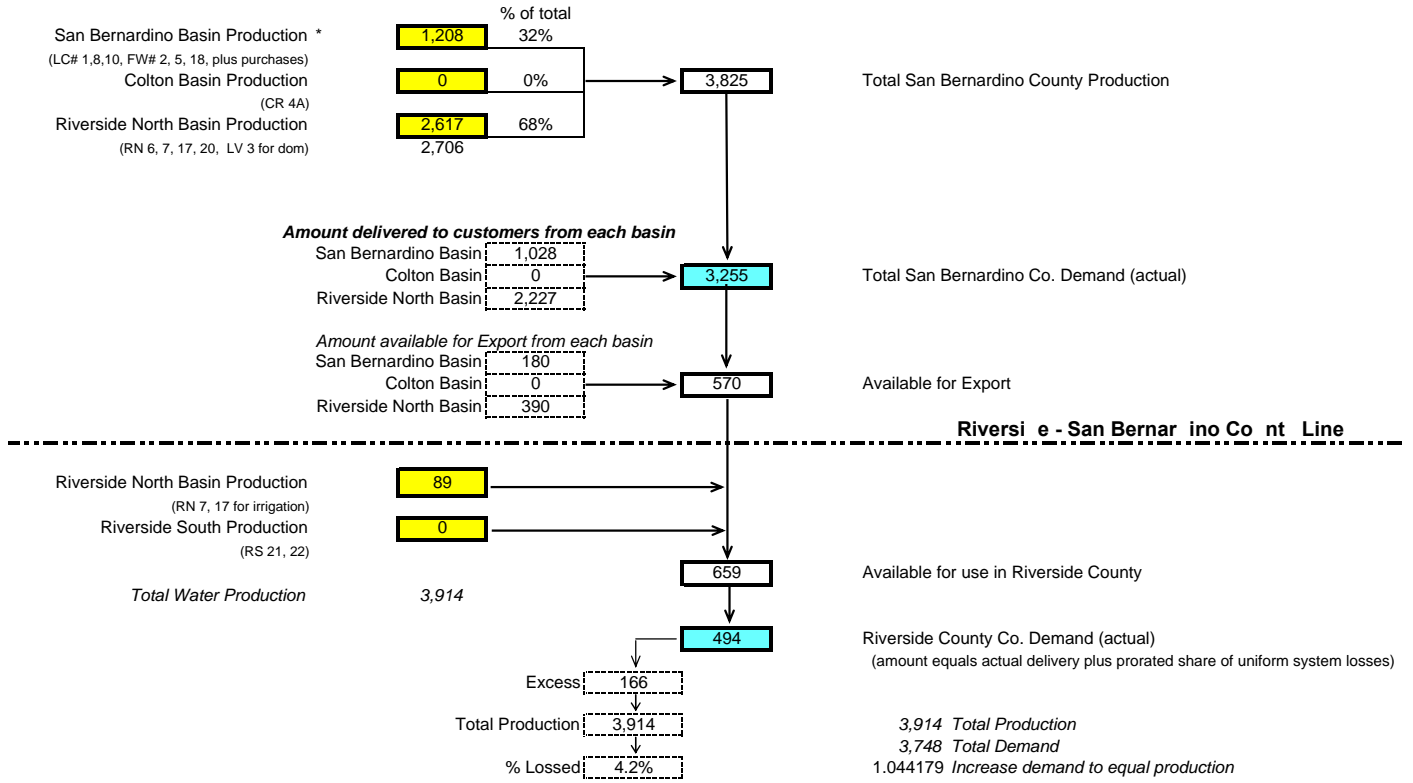
Riverside Hi lan Water Co pan 2008 Water S ppl Distrib tion



 Data from Watermaster Tables
 Data from Condensed Water Summary Report
 Values to check against calculated tables

Dia ra B

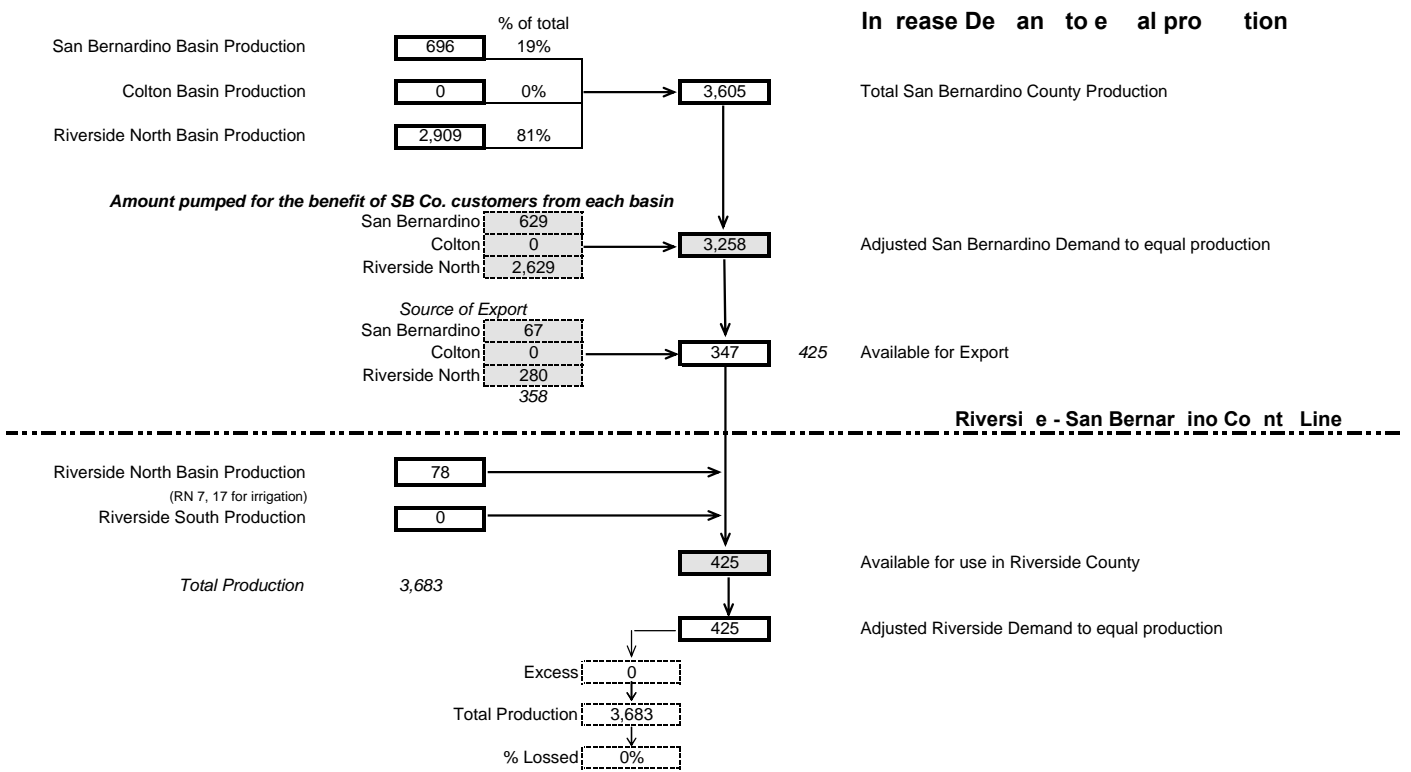
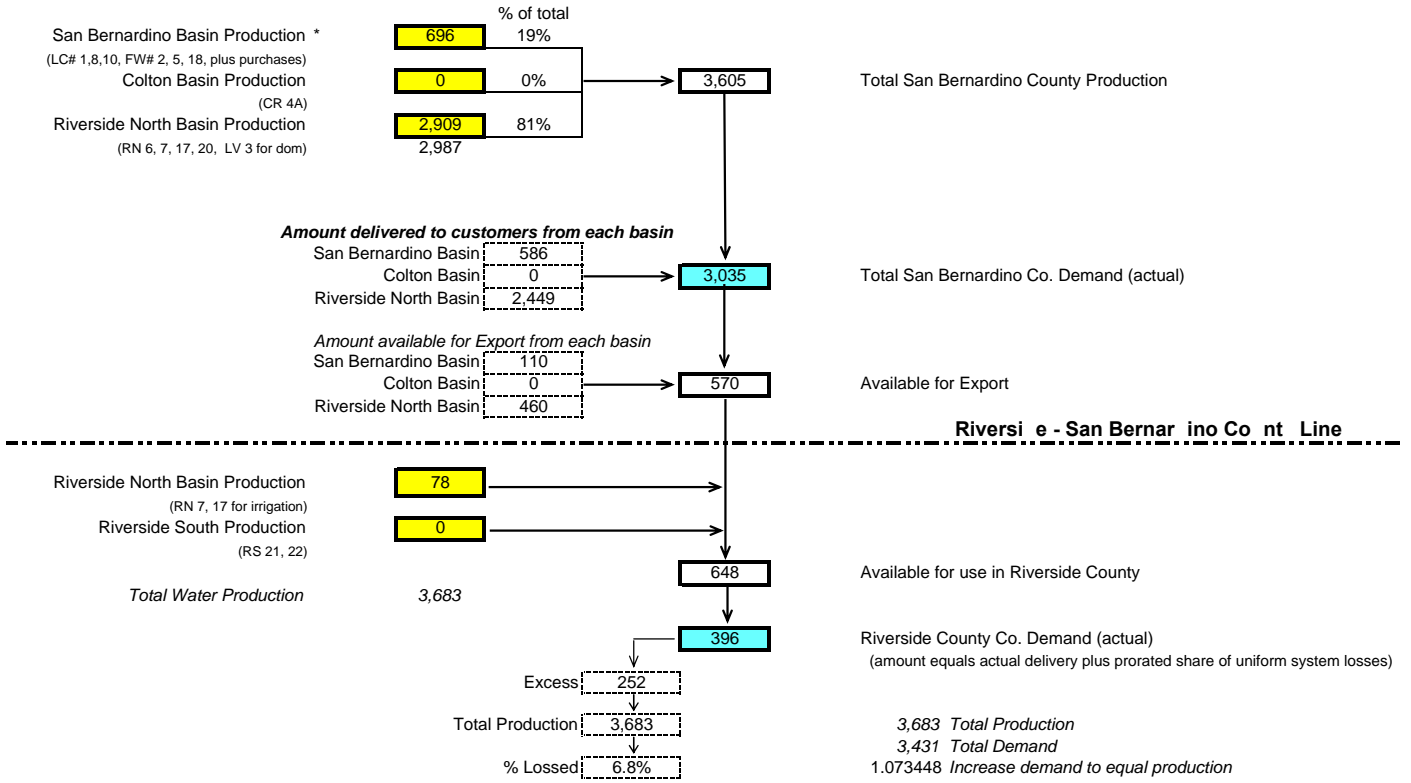
Riversi e Hi lan Water Co pan 2009 Water S ppl Distrib tion



 Data from Watermaster Tables
 Data from Condensed Water Summary Report
 Values to check against calculated tables

Dia ra B

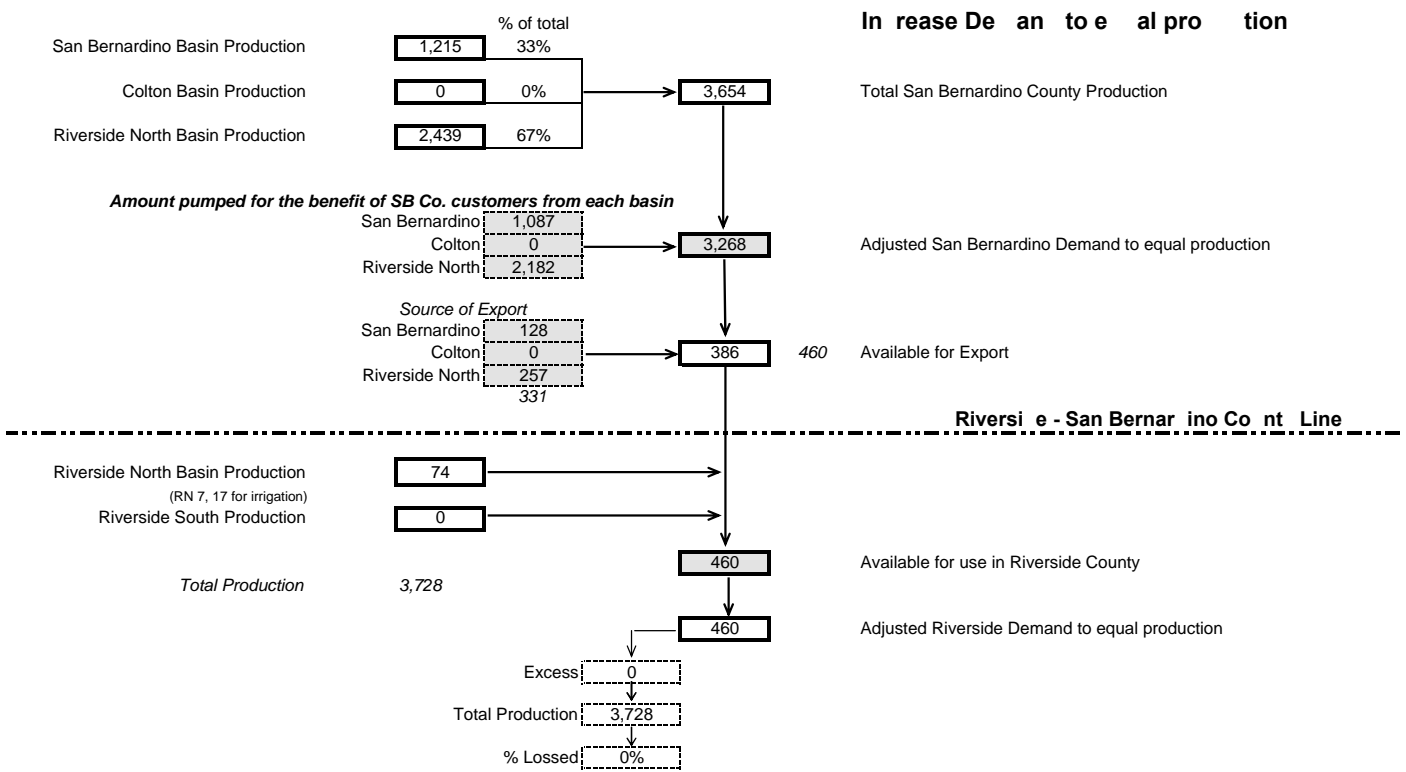
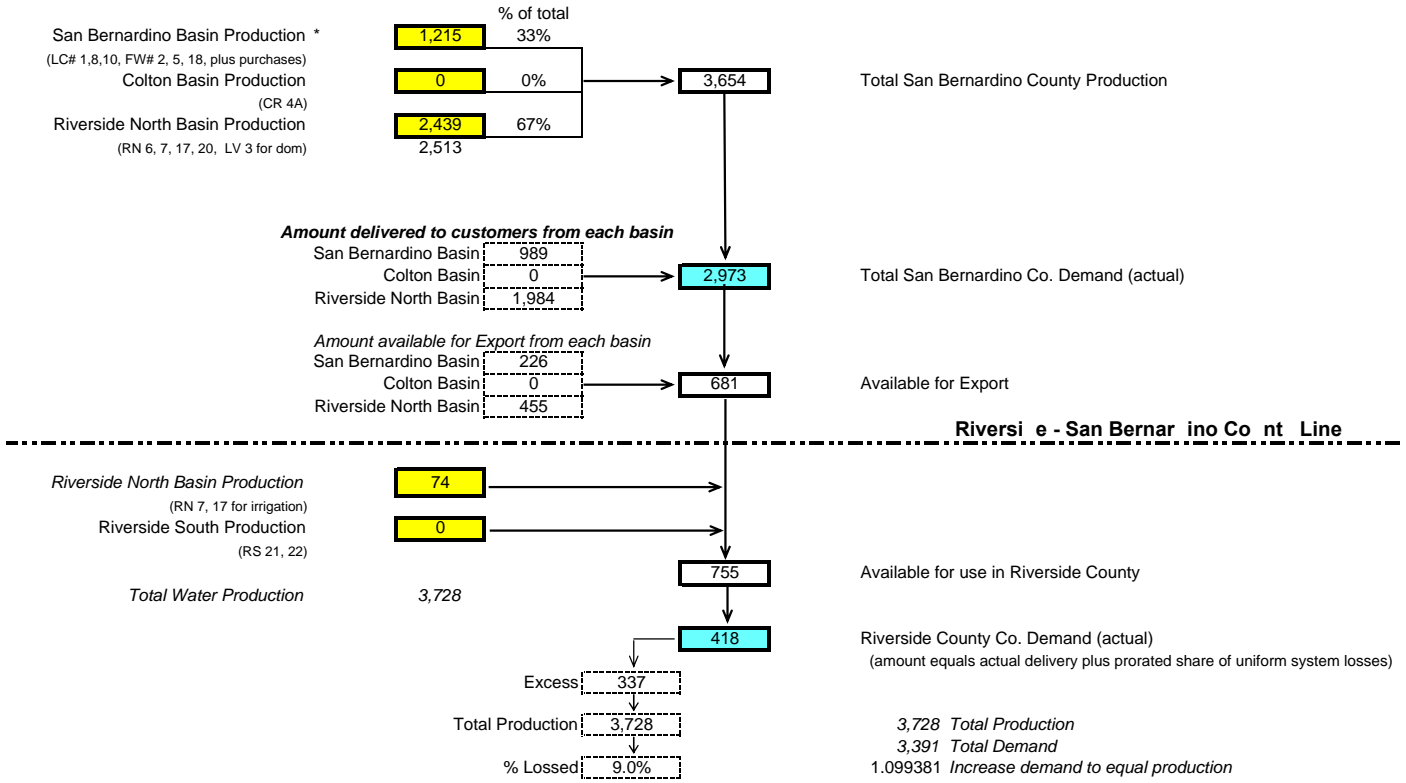
Riversi e Hi lan Water Co pan 2010 Water S ppl Distrib tion



 Data from Watermaster Tables
 Data from Condensed Water Summary Report
 Values to check against calculated tables

Dia ra B

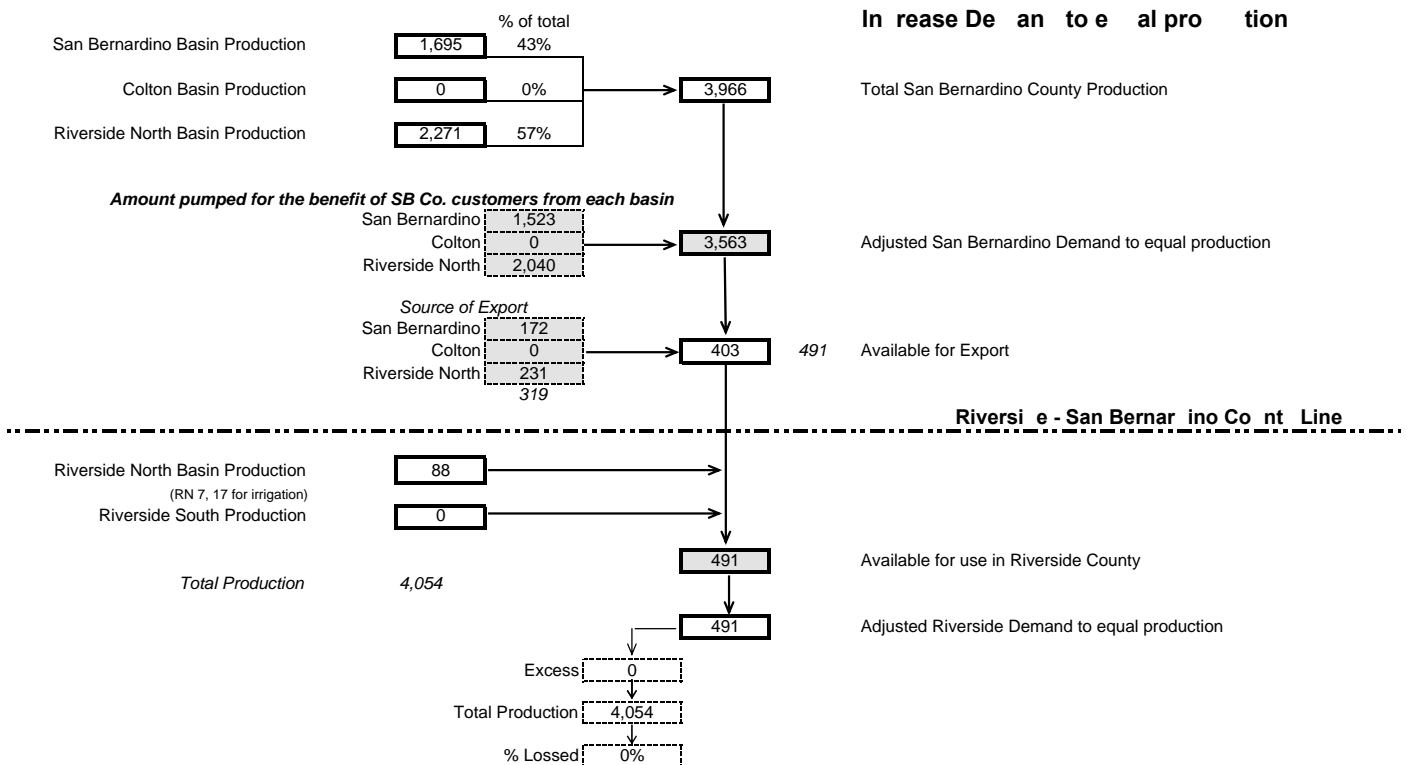
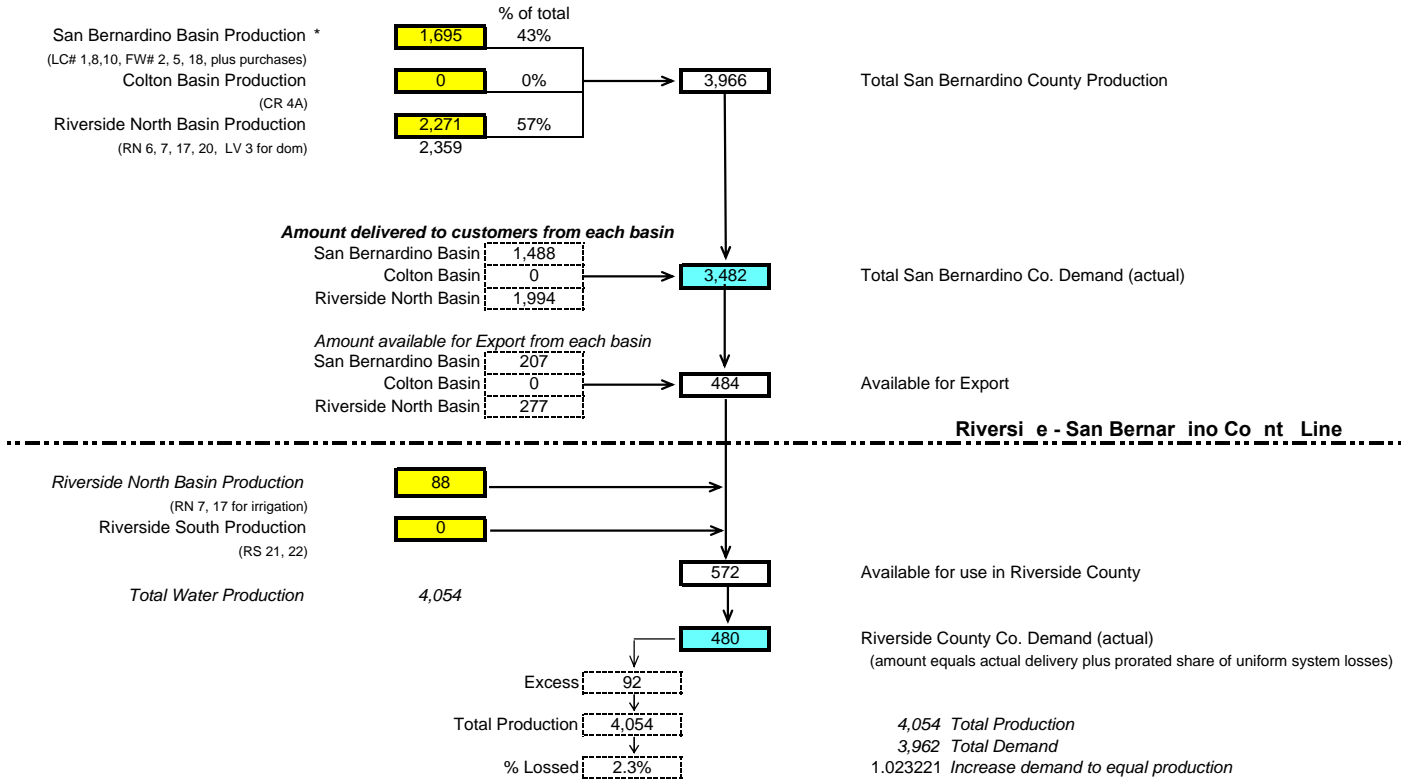
Riversi e Hi lan Water Co pan 2011 Water S ppl Distrib tion



Data from Watermaster Tables
 Data from Condensed Water Summary Report
 Values to check against calculated tables

Dia ra B

Riversi e Hi lan Water Co pan 2012 Water S ppl Distrib tion



 Data from Watermaster Tables
 Data from Condensed Water Summary Report
 Values to check against calculated tables

**WESTERN - SAN BERNARDINO WATERMASTER
FOR**

WESTERN MUNICIPAL WATER DISTRICT et al.

vs.

EAST SAN BERNARDINO COUNTY WATER DISTRICT et al.

CASE NO. 78426 - COUNTY OF RIVERSIDE

VOLUME 6 - 2012

**VERIFIED EXTRACTIONS FROM THE
SAN BERNARDINO BASIN AREA, COLTON BASIN AREA,
AND RIVERSIDE BASIN AREA FOR USE WITHIN WESTERN
ON LAND NOT TRIBUTARY
TO THE RIVERSIDE NARROWS**

**ANNUAL ACCOUNTING
2012**

April 1, 2014

WATERMASTER

Douglas D. Headrick

John V. Rossi

REPORT OF WATERMASTER

Western Municipal Water District of Riverside County, et al
Plaintiffs

vs.

East San Bernardino County Water District, et al
Defendants

Superior Court of Riverside County

Case No. 78426

Volume 6 - 2012

VERIFIED EXTRACTIONS FROM THE
SAN BERNARDINO BASIN AREA, COLTON BASIN AREA,
AND RIVERSIDE BASIN AREA FOR USE WITHIN WESTERN
ON LANDS NOT TRIBUTARY TO THE RIVERSIDE NARROWS

ANNUAL ACCOUNTING

April 1, 2014

WATERMASTER

Douglas D. Headrick
John V. Rossi

TABLE OF CONTENTS

Page

SECTION I
VERIFIED EXTRACTIONS FROM THE
SAN BERNARDINO BASIN AREA, COLTON BASIN AREA,
AND RIVERISDE BASIN AREA FOR USE WITHIN WESTERN
ON LANDS NOT TRIBUTARY TO THE RIVERSIDE NARROWS

INTRODUCTION 1

MAP No. 1 and 2

CANAL SYSTEMS DELIVERING WATER EXTRACTIONS FROM THE
SAN BERNARDINO BASIN AREA AND THE AREA DOWNSTREAM
THEREFROM TO THE RIVERSIDE NARROW AND AREA
NON-TRIBUTARY THERETO 5

TABLE A

VERIFIED EXTRACTIONS FOR USE ON LANDS NOT
TRIBUTARY TO RIVERSIDE NARROWS FOR CALENDAR
YEARS 1971 TO CURRENT YEAR 7

TABLE NO. 1

CITY OF RIVERSIDE NUMBER OF ACTIVE METERS MEASURING
WATER DELIVERED TO AREAS THAT ARE NOT TRIBUTARY
TO THE RIVERSIDE NARROWS 12

TABLE NO. 1A

DELIVERIES MADE BY CITY OF RIVERSIDE DOMESTIC
DIVISION TO AREAS WHICH ARE NOT TRIBUTARY TO
THE RIVERSIDE NARROWS 14

TABLE NO. 1B

WHOLESALE DELIVERIES MADE BY CITY OF RIVERSIDE
TO AREAS WHICH ARE NOT TRIBUTARY TO THE RIVERSIDE NARROWS
- Sales to Other Water Agencies 16

TABLE NO. 2

DELIVERIES MADE BY CITY OF RIVERSIDE IRRIGATION
DIVISION FROM RIVERSIDE CANAL TO AREAS WHICH ARE
NOT TRIBUTARY TO THE RIVERSIDE NARROWS 17

TABLE NO. 3

DELIVERIES MADE BY THE GAGE CANAL COMPANY TO AREAS
WHICH ARE NOT TRIBUTARY TO THE RIVERSIDE NARROWS 19

TABLE NO. 4

DELIVERIES BY CITY OF RIVERSIDE IRRIGATION DIVISION
FROM RIVERSIDE CANAL FOR USE ON LANDS NOT TRIBUTARY
TO THE RIVERSIDE NARROWS 21

TABLE NO. 5

DELIVERIES BY GAGE CANAL COMPANY FOR USE ON LANDS
NOT TRIBUTARY TO THE RIVERSIDE NARROWS 22

TABLE NO. 6

SUMMARY OF DELIVERIES MADE BY MEEKS & DALEY WATER
COMPANY, AGUA MANSA WATER COMPANY AND TEMESCAL
WATER COMPANY INCLUDING WATER RECEIVED FROM CITY
OF RIVERSIDE FROM THE RIVERSIDE AND GAGE CANALS
TO AREAS WHICH ARE NOT TRIBUTARY TO THE RIVERSIDE
NARROWS 24

TABLE NO. 6A

SUMMARY OF DELIVERIES MADE BY MEEKS & DALEY WATER
COMPANY, FROM CITY OF RIVERSIDE WATER SYSTEM
TO WESTERN MUNICIPAL WATER DISTRICT TO AREAS WHICH ARE NOT
TRIBUTARY TO THE RIVERSIDE NARROWS 26

TABLE NO. 7

WEST RIVERSIDE CANAL COMPANY DELIVERIES MADE TO
LATERALS #3 & #2 FOR USE IN GLEN AVON & PEDLEY AREAS
(FROM RECORDS OF WEST RIVERSIDE CANAL COMPANY) TO AREAS
WHICH ARE NOT TRIBUTARY TO THE RIVERSIDE NARROWS 27

TABLE NO. 8

NOT REQUIRED AFTER 1968

WEST RIVERSIDE CANAL COMPANY COMPARISON OF WATER DELIVERED TO CANAL BY WATER COMPANIES WITH CANAL COMPANY RECORDS OF WATER RECEIVED AND CALCULATED CANAL LOSSES	29
---	----

TABLE NO. 9

DELIVERIES MADE BY JURUPA COMMUNITY SERVICES DISTRICT TO AREAS NOT TRIBUTARY TO THE RIVERSIDE NARROWS	30
---	----

TABLE NO. 10

DELIVERIES MADE BY RUBIDOUX COMMUNITY SERVICES DISTRICT TO AREAS WHICH ARE NOT TRIBUTARY TO THE RIVERSIDE NARROWS	32
---	----

SECTION II
CREDIT FOR RETURN FLOW
RESULTING FROM DELIVERY OF IMPORTED WATER IN
AREAS TRIBUTARY TO THE RIVERSIDE NARROWS

<u>INTRODUCTION</u>	34
-------------------------------	----

TABLE NO. 11

CREDIT FOR RETURN FLOW RESULTING FROM DELIVERY OF IMPORTED WATER IN AREAS TRIBUTARY TO THE RIVERSIDE NARROWS	38
--	----

VOLUME 6 - 2012

SECTION I

VERIFIED EXTRACTIONS FROM THE
SAN BERNARDINO BASIN AREA, COLTON BASIN AREA,
AND RIVERSIDE BASIN AREA FOR USE WITHIN WESTERN
ON LANDS NOT TRIBUTARY TO THE RIVERSIDE NARROWS

The extractions from the San Bernardino, Colton and Riverside Basin Areas for use within Western Municipal Water District on lands not tributary to the Riverside Narrows have been verified for the five-year base period ending in 1963.

The resulting five-year annual average was determined to be 42,535 acre-feet, as shown in Table No. 12 at page 37 of Chapter VII of the Annual Report of the Western-San Bernardino Watermaster for Calendar Year 1971. A detailed report on the verification for the five-year base period 1959-1963, and for ensuing years 1964-1970, is contained in the Report of Watermaster, Volume 6, dated June 1972.

The extractions from the above mentioned basin areas for the Calendar years 1971 through 2012, which were delivered within Western for use on lands not tributary to the Riverside Narrows, have been verified by the Watermaster as follows:

<u>YEAR</u>	<u>VERIFIED DELIVERIES</u> (Acre Feet)
<u>1959-63 Average</u>	<u>42,535</u>
1971	41,612
1972	40,314
1973	31,133
1974	35,020
1975	38,737
1976	42,922
1977	37,113
1978	34,988
1979	39,963
1980	41,458
1981	40,505 ⁷⁾
1982	29,422
1983	28,952 ⁷⁾
1984	43,325 ⁷⁾

YEAR	VERIFIED DELIVERIES (Acre Feet)
------	------------------------------------

1959-63 Average	42,535
1985	39,355 ⁷⁾
1986	42,082 ⁷⁾
1987	38,826 ⁷⁾
1988	46,364 ⁷⁾
1989	45,841
1990	43,357
1991	46,606 ⁷⁾
1992	39,825 ⁷⁾
1993	36,876 ^{1) 7)}
1994	40,254 ⁷⁾
1995	37,296 ^{2) 7)}
1996	39,715 ^{6) 7)}
1997	39,546 ^{6) 7)}
1998	36,855 ^{2) 6) 7)}
1999	40,096 ^{3) 6) 7)}
2000	40,884 ^{3) 5) 6) 7)}
2001	38,792 ^{5) 6) 7)}
2002	38,399 ^{5) 6) 7)}
2003	38,534 ^{5) 6)}
2004	36,973 ^{5) 6) 7)}
2005	36,753 ^{5) 6)}
2006	37,783 ^{5) 6)}
2007	37,230 ^{4) 5) 6) 7)}
2008	38,261 ^{5) 6)}
2009	38,815 ^{5) 6)}
2010	37,891 ⁶⁾
2011	40,494
2012	39,682

This Volume 6 summarizes the total extractions and includes tables showing the detailed computations of the extractions by each entity. Table No. 8 was included in the original June 1972 Volume 6 for the period 1959-1968, but has been omitted and will not be included in future volumes.

- ¹⁾ Corrected during 1996 verification, July 1998
- ²⁾ Corrected during 1999 verification, June 2001
- ³⁾ Corrected during 2001 verification, July 2003 (to match Vol. 6, Table A)
- ⁴⁾ Corrected during 2008 verification, July 2009 (missed line 29, Table A)
- ⁵⁾ Corrected during 2010 verification, July 2011 (updates to M&D and RCSD tables)
- ⁶⁾ Corrected during 2011 verification, August 2012 (updated RCSD tables)
- ⁷⁾ Corrected during 2011 verification, June 2013 (SBBA Additional extraction removed from Table No. 1A)

During the 2010 Verification it was noted that several of the exports were not being properly accounted for.

Meeks & Daley (M&D) leased water deliveries to Western MWD (taken at the Jefferson Street Pump Station for the Non-Potable Distribution System) was not counted within M&D Export Table No. 6. The new Table No. 6A was added to record this export. Columns were included to account for future WMWD deliveries of leased M&D potable water at domestic interties.

It was also discovered that Riverside wholesale deliveries to Western MWD (at Mockingbird Canyon and Warmington interties) and to Home Gardens County Water District were not included in Table No. 1A, Column 10 as previously assumed. Table No. 1B was added to account for this exported water. (White Gate/Green Orchard intertie is within the Riverside South Basin).

Lines were added to the summation Table A for the new export generated in Table Nos. 1B and 6A.

And to round out an interesting year, it was noted that Rubidoux Community Services District started a wholesale connection to the Jurupa Community Services District in August of 2000. Table No. 10 was revised to include a new Column 6b to account for this wholesale export water.

During the 2011 Verification the Meeks & Daley leased water was again addressed. Table Nos. 1B and 6A were reworked to reflect the source of the water vs. place/type of delivery.

Rubidoux Community Services District submitted details of their service area in Chino Basin. With this new information, Table No. 10 figures were refined back to 1996.






All the earlier "type-written" tables were redone as Excel spreadsheets, and all of the tables in this report are fully linked to one another. A handful of minor typographical errors have been corrected but not footnoted.

In June 2013 during the work on Calendar Year 2011 data, the Watermaster modified several of the tables in the Annual Report. Table No. 14 was modified to include a line entitled "Additional New Export", which is defined as New Export that was allowed under the High Groundwater Mitigation agreements without replenishment. As a result, the deduction from New Export is now being made in Table No. 14. Therefore it is no longer necessary or appropriate to make the deduction in Volume 6, Table No. 1A, Column (15).

To accommodate this modification to the Annual Report, the amounts of additional extractions associated with the high groundwater mitigation have been deleted from Table No. 1A Column (15) and the column is labeled "Column Not Used". The results of this change are reflected as increases in amounts shown in Table No. 1A, Column (16) and the first and last lines of Table A.

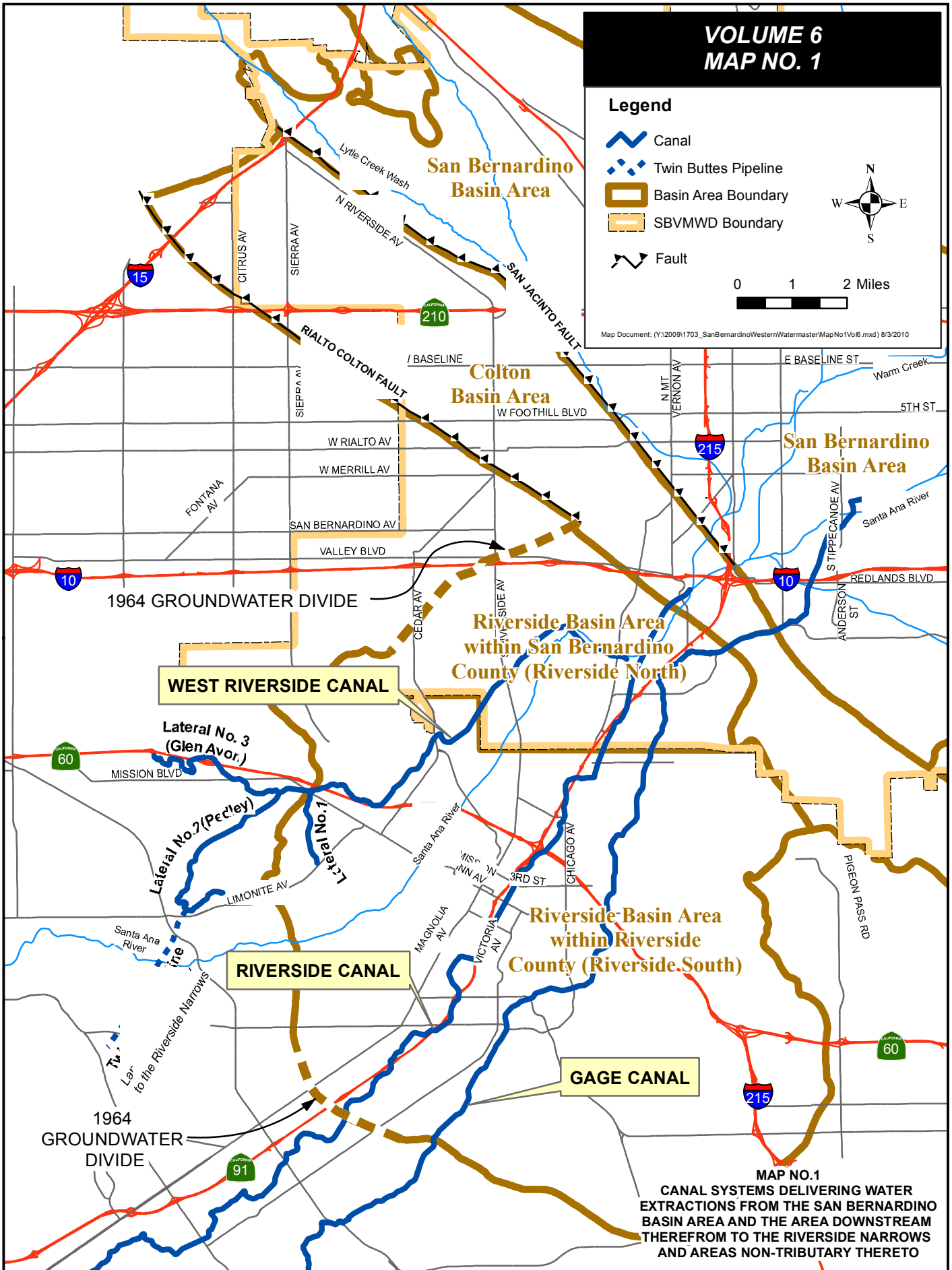
**VOLUME 6
MAP NO. 1**

Legend

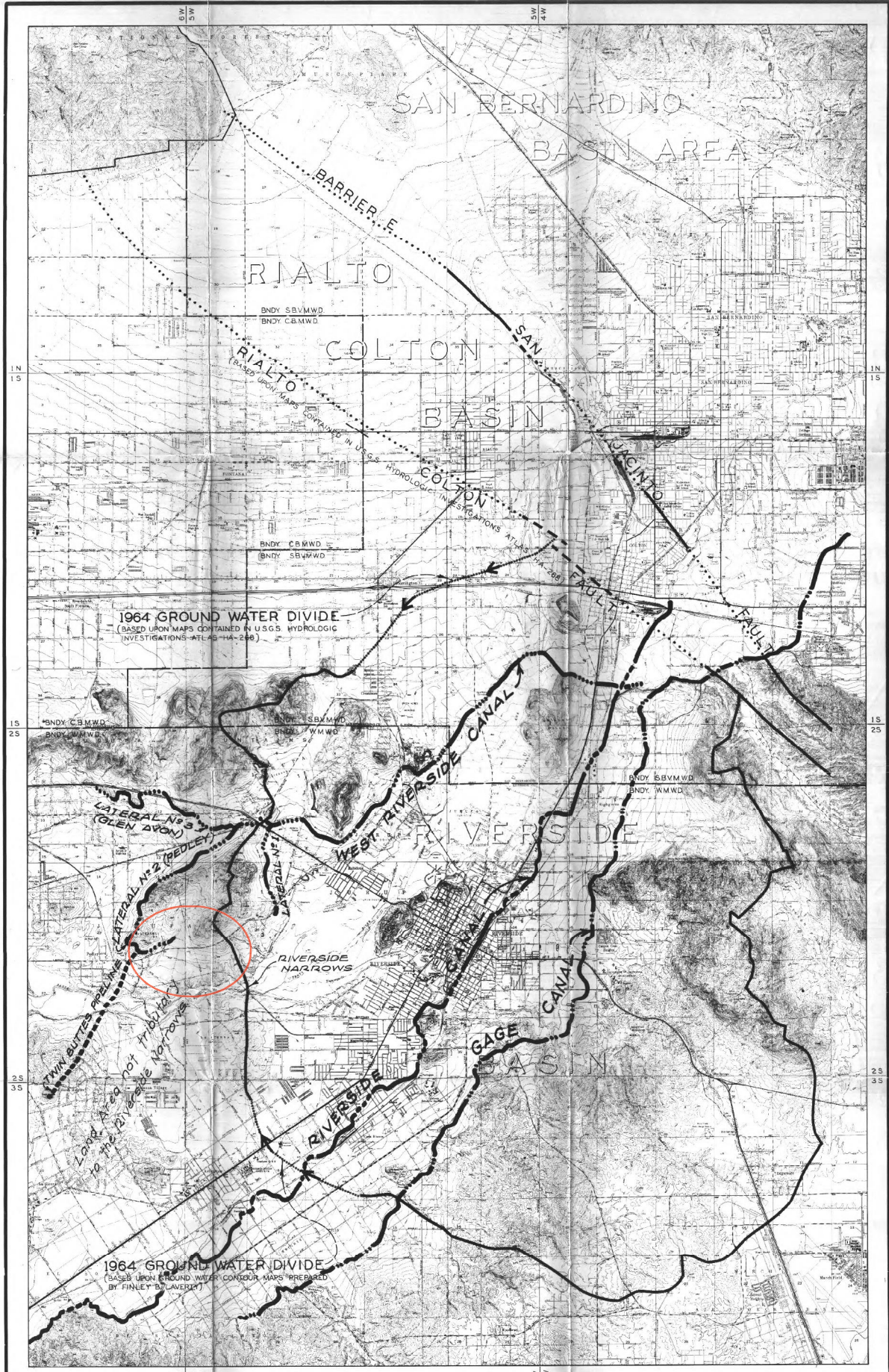
-  Canal
-  Twin Buttes Pipeline
-  Basin Area Boundary
-  SBVMWD Boundary
-  Fault



Map Document: (Y:\2009\1703_SanBernardinoWesternWatermaster\MapNo1Vo6.mxd) 8/3/2010



MAP NO.1
CANAL SYSTEMS DELIVERING WATER
EXTRACTIONS FROM THE SAN BERNARDINO
BASIN AREA AND THE AREA DOWNSTREAM
THEREFROM TO THE RIVERSIDE NARROWS
AND AREAS NON-TRIBUTARY THERETO



MAP No 1
SHOWING

CANAL SYSTEMS DELIVERING WATER EXTRACTATIONS FROM THE SAN BERNARDINO BASIN AREA AND THE AREA DOWNSTREAM THEREFROM TO THE RIVERSIDE NARROWS AND AREAS NON-TRIBUTARY THERETO



ALBERT A. WEBB ASSOCIATES
CIVIL ENGINEERS RIVERSIDE, CALIFORNIA

TABLE A

**VERIFIED EXTRACTIIONS FOR USE ON
LANDS NOT TRIBUTARY TO RIVERSIDE NARROWS
FOR CALENDAR YEARS 1971 THROUGH CURRENT YEAR**

(All Quantities are in Acre Feet)

Ln #	Water Extracted and Delivered by	From Table No.	Column or Line #	1959-63 Base Period Average	DELIVERIES BY CALENDAR YEAR															
					1971	1972	1973	1974	1975	1976	1977	1978	1979	1980						
1	City of Riverside																			
2	Domestic Division	1A	16	3,05C	7,736	7,284	8,299	9,308	10,688	13,652	13,742	16,369	18,345	17,965						
3	Irrigation Division (1)	2	7	4,075	1,866	1,503	1,37C	1,387	1,981	1,181	609	244	222	255						
4	Gage Canal (2)	3	5	16,711	17,014	16,629	12,835	14,137	15,749	15,623	14,61C	11,559	12,325	14,264						
5	Total			23,836	26,616	25,416	22,504	24,832	28,418	30,456	28,961	28,172	30,892	32,484						
6	Meeks & Daley Water Company																			
7	Agua Mansa Water Company & the Temescal Water Company																			
8	including water received from C of R	6	3	13,229	8,195	8,57C	4,291	4,667	4,711	6,848	4,002	4,012	5,57C	6,21C						
9	Extractiions delivered by the West Riverside Canal received from Twin Buttes Water Co., La Sierra Water Co., Agua Mansa Water Co., Salazar Water Co., West Riverside 350" Water Co., and Jurupa Water Co.	7	8	4,903	5,952	5,456	3,71C	4,869	4,875	4,629	3,222	1,981	2,707	2,506						
10	Jurupa Community Services District	9	7	531	794	807	545	566	64C	865	773	61C	55C	3						
11	Rubidoux Community Service District	10	7	36	55	65	83	86	93	124	156	213	244	254						
12	TOTALS			42,535	41,612	40,314	31,133	35,02C	38,737	42,922	37,113	34,988	39,963	41,458						

NOTES:

- (1) City Irrigation Divison includes the former Riverside Water Company
- (2) Deliveries to Gage Canal Shareholders
- (3) Deliveries made from Laterals 3 & 2 of West Riverside Canal Company
- (4) Deliveries made by Rubidoux Community Services District prior to 1968
- (5) Deliveries made by Jurupa Hills Water Company before its purchase by Rubidoux Community Services District in 1968

TABLE A

VERIFIED EXTRACTIONS FOR USE ON
LANDS NOT TRIBUTARY TO RIVERSIDE NARROWS
FOR CALENDAR YEARS 1971 THROUGH CURRENT YEAR

(All Quantities are in Acre Feet)

Ln #	Water Extracted and Delivered by	From Column Table No.	of Line #	1959-63 Base Period Average	DELIVERIES BY CALENDAR YEAR														
					1981	1982	1983	1984	1985	1986	1987	1988	1989	1990					
1	City of Riverside																		
2	Domestic Division	1A	16	3,050	19,029	14,597	15,352	19,088	19,095	20,994	22,186	23,829	24,311	26,028					
3	Irrigation Division (1)	2	7	4,075	273	0	-	-	-	-	-	-	-	-	-	-	-	-	-
4	Gage Canal (2)	3	5	16,711	11,823	8,777	9,208	16,339	13,353	14,117	10,223	15,038	14,727	12,866					
5	Total			23,836	31,125	23,374	24,560	35,427	32,448	35,111	32,409	38,867	39,038	38,894					
6																			
7	Meeks & Daley Water Company																		
8	Agua Mansa Water Company & the																		
9	Temescal Water Company																		
10	including water received from C of R	6	3	13,229	5,974	4,690	3,299	5,895	4,738	5,417	5,500	5,412	5,307	3,057					
11																			
12	Extractions delivered by the (3)																		
13	West Riverside Canal received from																		
14	Twin Buttes Water Co., La Sierra Water																		
15	Co., Agua Mansa Water Co., Salazar																		
16	Water Co., West Riverside 350"																		
17	Water Co., and Jurupa Water Co.	7	8	4,903	3,146	1,106	817	1,160	945	681	671	1,817	833	881					
18																			
19	Jurupa Community Services District	9	6	531	0	0	0	527	900	545	0	1	397	277					
20																			
21	Rubidoux Community Services District	10	7	36	260	252	276	316	324	328	246	267	266	248					
22																			
23	TOTALS			42,535	40,505	29,422	28,952	43,325	39,355	42,082	38,826	46,364	45,841	43,357					

NOTES:
 (1) City Irrigation Division includes the former Riverside Water Company
 (2) Deliveries to Gage Canal Shareholders
 (3) Deliveries made from Laterals 3 & 2 of West Riverside Canal Company

TABLE A

VERIFIED EXTRACTIIONS FOR USE ON
LANDS NOT TRIBUTARY TO RIVERSIDE NARROWS
FOR CALENDAR YEARS 1971 THROUGH CURRENT YEAR

(All Quantities are in Acre Feet)

Ln #	Water Extracted and Delivered by	From Table No.	Column or Line #	1959-63 Base Period Average	1991	1992	1993	1994	1995	1996	1997	1998	1999	2000
1	City of Riverside													
2	Domestic Division	1A	16	3,050	23,275	24,890	21,932	24,053	23,339	25,239	25,177	25,186	23,686	24,983
3	Irrigation Division (1)	2	7	4,075	-	-	-	-	-	-	-	-	-	-
4	Gage Canal (2)	3	5	16,711	17,461	10,574	10,925	13,609	12,228	12,921	12,969	10,852	15,080	13,675
4a	Deliveries to other agencies (4)	1B	6											306
5	Total			23,836	40,736	35,464	32,857	37,662	35,567	38,160	38,146	36,038	38,766	38,964
6														
7	Meeks & Daley Water Company													
8	Agua Mansa Water Company & the Temescal Water Company													
9														
10	including water received from C of R	5	3		4,723	3,495	3,249	1,870	1,028	978	1,022	476	989	1,122
10a	Deliveries to Western Municipal W.D.	6A	5											
10b	Total			13,229	4,723	3,495	3,249	1,870	1,028	978	1,022	476	989	1,122
11														
12	Extractions delivered by the (3)													
13	West Riverside Canal received from													
14	Twin Buttes Water Co., La Sierra													
15	Water Co., Agua Mansa Water Co.,													
16	Salazar Water Co., West Riverside 350"													
17	Water Co., and Jurupa Water Co.	7	8	4,903	591	382	236	236	185	0	0	0	0	0
18														
19	Jurupa Community Services District	9	6	531	203	242	278	236	266	236	37	0	0	0
20														
21	Rubidoux Community Services District	10	7	36	253	242	256	250	250	341	341	341	341	798
22														
23	TOTALS			42,535	46,606	39,825	36,876	40,254	37,296	39,715	39,546	36,855	40,096	40,884

NOTES:

- (1) City Irrigation Division includes the former Riverside Water Company
- (2) Deliveries to Gage Canal Shareholders
- (3) Deliveries made from Laterals 3 & 2 of West Riverside Canal Company
- (4) Deliveries to Home Gardens County Water District

TABLE A

VERIFIED EXTRACTIONS FOR USE ON
LANDS NOT TRIBUTARY TO RIVERSIDE NARROWS
FOR CALENDAR YEARS 1971 THROUGH CURRENT YEAR

(All Quantities are in Acre Feet)

Ln #	Water Extracted and Delivered by	From Column Table or Line #	1959-63 Base Period Average	DELIVERIES BY CALENDAR YEAR																
				2001	2002	2003	2004	2005	2006	2007	2008	2009	2010							
1	City of Riverside																			
2	Domestic Division	1A	3,050	25,121	25,406	26,067	26,500	27,030	27,571	28,000	27,936	24,684	23,036							
3	Irrigation Division (1)	2	4,075	-	-	-	-	-	-	-	-	-	-							
4	Gage Canal (2)	3	16,711	11,839	12,195	10,015	9,364	8,178	8,464	7,456	7,121	7,320	7,748							
4a	Deliveries to other agencies (4)	1B		369	363	369	397	395	394	451	336	361	371							
5	Total		23,836	37,329	37,964	36,451	36,261	35,603	36,429	35,907	35,393	32,365	31,155							
6																				
7	Meeks & Daley Water Company																			
8	Agua Mansa Water Company & the																			
9	Temescal Water Company																			
10	including water received from C of R	6		356	94	104	18	11	10	10	9	9	10							
10a	Deliveries to Western Municipal W.D. (5)	6A				1,481	0	217	285	42	1,772	5,087	5,168							
10b	Total		13,229	356	94	1,585	18	228	295	52	1,781	5,096	5,178							
11																				
12	Extractions delivered by the (3)																			
13	West Riverside Canal received from																			
14	Twin Buttes Water Co., La Sierra																			
15	Water Co., Agua Mansa Water Co.,																			
16	Salazar Water Co., West Riverside 350"																			
17	Water Co., Jurupa Water Co., Indian Hills	7		0	0	0	221	487	515	563	575	533	475							
17a	Water Conservation Assoc & Empire Water Co.																			
18																				
19	Jurupa Community Services District	9		0	0	0	0	0	0	0	0	0	0							
20																				
21	Rubidoux Community Services District	10		1,107	341	488	473	435	544	708	512	821	1,083							
22																				
23	TOTALS		42,535	38,792	38,399	38,534	36,973	36,753	37,783	37,230	38,261	38,815	37,891							

NOTES:

- (1) City Irrigation Division includes the former Riverside Water Company
- (2) Deliveries to Gage Canal Shareholders
- (3) Deliveries made from Laterals 3 & 2 of West Riverside Canal Company
- (4) Deliveries to Home Gardens County Water District
- (5) Meeks & Daley water delivered to WMWD from Riverside system

June 2013 - see Footnote on Table 1A SBBA Additional Extractions removed from Volume 6 and is now a credit on Annual Report Table 14

TABLE A

**VERIFIED EXTRACTIONS FOR USE ON
LANDS NOT TRIBUTARY TO RIVERSIDE NARROWS
FOR CALENDAR YEARS 1971 THROUGH CURRENT YEAR**

(All Quantities are in Acre Feet)

Ln. #	Water Extracted and Delivered by	From Column Table or No. Line #	1959-63 Base Period Average	DELIVERIES BY CALENDAR YEAR														
				2011	2012	2013	2014	2015	2016	2017	2018	2019	2020					
1	City of Riverside																	
2	Domestic Division	1A	3,050	24,160	24,691													
3	Irrigation Division (1)	2	4,075	-	-	-	-	-	-	-	-	-	-	-	-	-	-	-
4	Gage Canal (2)	3	16,711	8,901	9,267													
4a	Deliveries to other agencies (4)	1B		354	454													
5	Total		23,836	33,415	34,412													
6																		
7	Meeks & Daley Water Company																	
8	Agua Mansa Water Company & the																	
9	Temescal Water Company																	
10	including water received from C of R	6	3	10	11													
10a	Deliveries to Western Municipal W.D. (5)	6A		5,463	3,710													
10b	Total		13,229	5,473	3,721													
11																		
12	Extractions delivered by the (3)																	
13	West Riverside Canal received from																	
14	Twin Buttes Water Co., La Sierra																	
15	Water Co., Agua Mansa Water Co.,																	
16	Salazar Water Co., West Riverside 350"																	
17	Water Co., Jurupa Water Co., Indian Hills	7	8	456	503													
17a	Water Conservation Assoc & Empire Water Co.																	
18																		
19	Jurupa Community Services District	9	6	C	C													
20																		
21	Rubidoux Community Services District	10	7	1,150	1,046													
22																		
23	TOTALS		42,535	40,494	39,682													

NOTES:
 (1) City Irrigation Division includes the former Riverside Water Company
 (2) Deliveries to Gage Canal Shareholders
 (3) Deliveries made from Laterals 3 & 2 of West Riverside Canal Company
 (4) Deliveries to Home Gardens County Water District
 (5) Meeks & Daley water delivered to WMD from Riverside system
 June 2013 - see Footnote on Table 1A SBBA Additional Extractions removed from Volume 6 and is now a credit on Annual Report Table 14

CITY OF RIVERSIDE
NUMBER OF ACTIVE METERS
MEASURING WATER DELIVERED TO AREAS
THAT ARE NOT TRIBUTARY TO THE RIVERSIDE NARROWS

		Number of Active Meters								
Meter Book Area		1	13	14	15	16	17	18	19	22
		(1)	(2)	(3)	(4)	(5)	(6)	(7)	(8)	(9)
Calendar Year	Total Meters									
1971	7,375	203	1,677	2,151		2,389			871	84
1972	7,667	239	1,776	2,243		2,407			913	89
1973	8,138	229	1,765	2,760		2,330			966	88
1974	8,180	197	1,795	2,804		2,325			971	88
1975	14,163	428	1,980	4,045	3,027	2,357	509	562	1,149	106
1976	16,233	659	2,166	5,287	3,220	2,378	509	562	1,328	124
1977	18,304	877	2,242	5,185	5,799	2,465			1,607	129
1978	22,189	917	2,367	5,535	8,680	2,686			1,833	171
1979	22,441	709	2,377	5,740	8,879	2,608			1,965	163
1980	23,302	491	2,857	5,791	9,344	2,645			2,011	163
1981	23,302	491	2,857	5,791	9,344	2,645			2,011	163
1982	20,421	584	2,195	3,259	9,799	2,394			2,073	117
1983**	20,766	-	-	-	-	-	-	-	-	-
1984	21,336	-	-	-	-	-	-	-	-	-
1985	21,669	-	-	-	-	-	-	-	-	-
1986	22,658	-	-	-	-	-	-	-	-	-
1987	23,107	-	-	-	-	-	-	-	-	-
1988	23,688	-	-	-	-	-	-	-	-	-
1989	24,311	-	-	-	-	-	-	-	-	-
1990	24,782	-	-	-	-	-	-	-	-	-
1991	25,147 *	-	-	-	-	-	-	-	-	-
1992	25,197 *	-	-	-	-	-	-	-	-	-
1993	25,244 *	-	-	-	-	-	-	-	-	-
1994	25,263	-	-	-	-	-	-	-	-	-
1995	25,286	-	-	-	-	-	-	-	-	-

Data from City of Riverside Records

Column (4) - Starting July 1, 1973, the City of Riverside took over operation of the Southwest Water Company (Meter Book area 15).

At the time water used in that area was reported directly in Acre Feet [See Table 1A, Column (4)].

In 1975 Meter Book Areas 17 and 18 were split off of Meter Book 15 and all three areas are now reported by number of active meters.

In 1977 Meter Book Areas 17 and 18 were recombined with Meter Book 15.

In 1977 Meter Book Areas 17 and 18 were recombined with Meter Book 15.

* Corrected values

** Starting in 1983, the City is able to generate an annual tabulation of water use in areas not tributary to the Riverside Narrows.

TABLE NO. 1

CITY OF RIVERSIDE
NUMBER OF ACTIVE METERS
MEASURING WATER DELIVERED TO AREAS
THAT ARE NOT TRIBUTARY TO THE RIVERSIDE NARROWS

Meter Book Area	Retail Total Meters	Number of Active Meters								
		1 (1)	13 (2)	14 (3)	15 (4)	16 (5)	17 (6)	18 (7)	19 (8)	22 (9)
1996	25,239	-	-	-	-	-	-	-	-	-
1997	25,177	-	-	-	-	-	-	-	-	-
1998	25,186	-	-	-	-	-	-	-	-	-
1999	23,686	-	-	-	-	-	-	-	-	-
2000	24,983	-	-	-	-	-	-	-	-	-
2001	25,121	-	-	-	-	-	-	-	-	-
2002	25,406	-	-	-	-	-	-	-	-	-
2003	26,067	-	-	-	-	-	-	-	-	-
2004	26,500	-	-	-	-	-	-	-	-	-
2005	26,659	-	-	-	-	-	-	-	-	-
2006	26,819	-	-	-	-	-	-	-	-	-
2007	27,000	-	-	-	-	-	-	-	-	-
2008	25,346	-	-	-	-	-	-	-	-	-
2009	24,237	-	-	-	-	-	-	-	-	-
2010	24,118	-	-	-	-	-	-	-	-	-
2011	23,036	-	-	-	-	-	-	-	-	-
2012	22,241	-	-	-	-	-	-	-	-	-
2013		-	-	-	-	-	-	-	-	-
2014		-	-	-	-	-	-	-	-	-
2015		-	-	-	-	-	-	-	-	-
2016		-	-	-	-	-	-	-	-	-
2017		-	-	-	-	-	-	-	-	-
2018		-	-	-	-	-	-	-	-	-
2019		-	-	-	-	-	-	-	-	-
2020		-	-	-	-	-	-	-	-	-
2021										
2022										
2023										
2024										
2025										

Data from City of Riverside Records

Column (4) - Starting July 1, 1973, the City of Riverside took over operation of the Southwest Water Company (Meter Book area 15).

At the time water used in that area was reported directly in Acre Feet [See Table 1A, Column (4)].

In 1975 Meter Book Areas 17 and 18 were split off of Meter Book 15 and all three areas are now reported by number of active meters.

In 1977 Meter Book Areas 17 and 18 were recombined with Meter Book 15.

In 1977 Meter Book Areas 17 and 18 were recombined with Meter Book 15.

* Corrected values

** Starting in 1983, the City is able to generate an annual tabulation of water use in areas not tributary to the Riverside Narrows.

TABLE NO. 1A

DELIVERIES MADE BY CITY OF RIVERSIDE
DOMESTIC DIVISION TO AREAS WHICH ARE NOT TRIBUTARY TO THE RIVERSIDE NARROWS

Meter Book Area	D e l i v e r i e s i n A c r e F e e t										Arlington Basin Production				Total From Upper Basin Not Tributary (16)
	1 (1)	2 (2)	3 (3)	4 (4)	5 (5)	6 (6)	7 (7)	8 (8)	9 (9)	10 (10)	W.M.W.D.		Southwest Water Co. Wells (14)	Column Not Used (15)	
											Total Treated (12)	Used in Arlington (13)			
1959-63 Base Period Average										3,886	315	521			3,050
Calendar Year															
1971	168	1,389	2,968	2,308	841	139	7,813	68	13	9	7,736				7,736
1972	178	1,321	2,781	2,089	793	132	7,294	1	13	9	7,284				7,284
1973	147	1,130	2,926	2,941	1,729	714	9,699	29	18	12	8,299		1,359		8,299
1974	131	1,195	3,112	3,945	1,807	754	11,061	69	49	33	9,308		1,651		9,308
1975	277	1,283	4,369	1,962	1,782	330	11,373	0	904	602	10,688		83		10,688
1976	439	1,443	5,869	2,145	1,855	361	13,707	31	7	11	13,652		13		13,652
1977	535	1,368	5,288	3,855	1,750		14,094	143	17	11	13,742		198		13,742
1978	514	1,586	6,144	5,012	2,095		17,108	739	0	0	16,369		0		16,369
1979	503	1,688	6,831	5,930	2,165		18,981	633	4	3	18,345		0		18,345
1980	314	1,828	6,138	6,268	1,957		18,200	127	161	108	17,965		0		17,965
1981	329	1,914	6,428	6,818	2,063		19,338	280	0	0	19,029		29		19,029
1982	356	1,339	3,324	6,290	1,699		14,597	0	0	0	14,597		0		14,597
1983	-	-	-	-	-	-	15,352	0	0	0	15,352		0		15,352
1984	-	-	-	-	-	-	19,088	0	0	0	19,088		0		19,088
1985	-	-	-	-	-	-	19,095	0	0	0	19,095		0		19,095
1986	-	-	-	-	-	-	20,994	0	11	0	20,994		0		20,994
1987	-	-	-	-	-	-	22,199	0	20	13	22,186		0		22,186
1988	-	-	-	-	-	-	23,829	0	1	0	23,829		0		23,829
1989	-	-	-	-	-	-	24,311	0	0	0	24,311		0		24,311
1990	-	-	-	-	-	-	26,028	0	0	0	26,028		0		26,028
1991	-	-	-	-	-	-	23,275	0	0	0	23,275		0		23,275
1992	-	-	-	-	-	-	24,890	0	0	0	24,890		0		24,890
1993	-	-	-	-	-	-	21,932	0	0	0	21,932		0		21,932
1994	-	-	-	-	-	-	24,053	0	0	0	24,053		0		24,053
1995	-	-	-	-	-	-	23,339	0	0	0	23,339		0		23,339

Columns (1) through (9) were estimated as follows: Using the factor Acre Feet per connection, obtained for the year 1965 for each Meter Book Area said duty use factors were adjusted for subsequent and preceding years to compensate for consumptive variances, due to temperature and rainfall, by a ratio based on the ratio of total Annual System Production to Annual System Population for each year as compared to the same ratio for the year 1965.

Column (4) - Starting on July 1, 1973, the City of Riverside took over operation of the Southwest Water Company (Meter Book Area 15). At the time water use in that area was reported directly in acre feet.

Columns (6) and (7) - In 1975, Meter Book areas 17 and 18 were split off of Meter Book 15 and all three areas are now reported by number of active meters.

Column (10) = Total of Columns (1) through (9).

Column (12) = Total treated W.M.W.D. CRA water via WR-10 to the City of Riverside Filter Plant.

Column (13) = Column (12) x 2/3.

Column (14) = Total production from former Southwest Water Company Wells.

Column (15) = During the verification process for the 2011 reporting, the amounts of high groundwater mitigation

additional extractions were deleted because such amounts were included in a modification

of Table 14 in the Annual Report. Therefore the data in the column has been removed.

Column (16) = Column (10) minus Columns (11) (13) (14) and (15).

See notes on Table 1 about Meter Book number changes.

TABLE NO. 1A

DELIVERIES MADE BY CITY OF RIVERSIDE
DOMESTIC DIVISION TO AREAS WHICH ARE NOT TRIBUTARY TO THE RIVERSIDE NARROWS

Meter Book Area	D e l i v e r i e s i n A F										Arlington Basin Production			Total From Upper Basin Not Tributary							
	1	2	3	4	5	6	7	8	9	W.M.W.D.		Southwest Water Co. Wells	Column Not Used								
	(1)	(2)	(3)	(4)	(5)	(6)	(7)	(8)	(9)	Total Treated	Used in Arlington				(14)	(15)					
1959-63 Base Period Average	3,886										315	521	3,050								
Calendar Year	1896	1897	1898	1899	1900	1901	1902	1903	1904	1905	1906	1907	1908	1909	1910	1911	1912	1913	1914	1915	1916
	25,239	25,177	25,186	23,886	24,983	25,121	25,406	26,067	26,500	27,030	27,571	28,000	27,936	24,684	23,036	24,160	24,691	-	-	-	-

Columns (1) through (9), starting in 1983 Riverside provided a total number of estimated water meters in the area not-tributary to the Riverside Narrows along with an estimated water use.
 Column (10) = Starting in 1983, City estimated number of water meters serving areas not-tributary to the Riverside Narrows.
 Column (12) = Total treated W.M.W.D. CRA water via WR-10 to the City of Riverside Filter Plant.
 Column (13) = Column (12) x 2/3.
 Column (14) = Total production from former Southwest Water Company Wells.
 Column (15) = During the verification process for the 2011 reporting, the amounts of high groundwater mitigation additional extractions were deleted because such amounts were included in a modification of Table 14 in the Annual Report. Therefore the data in the column has been removed.
 Column (16) = Column (10) minus Columns (11) (13) (14) and (15).

WHOLESALE DELIVERIES MADE BY CITY OF RIVERSIDE
TO AREAS WHICH ARE NOT TRIBUTARY TO THE RIVERSIDE NARROWS

Sales to other water agencies

Calendar Year	Deliveries to Western MWD				Home Garden County Water District	Total Wholesale Water Deliveries
	Mockingbird	Warmington	C of R	Total Deliveries		
	Canyon	Lake Hills	Jefferson St.	to WMWD		
	(1)	(2)	(3)	(4)	(5)	(6)
RPU station #					8000	
1996						
1997						
1998						
1999						
2000				-	306	306
2001				-	369	369
2002				-	363	363
2003				-	369	369
2004				-	397	397
2005				-	395	395
2006				-	394	394
2007				-	451	451
2008				-	336	336
2009				-	361	361
2010				-	371	371
2011				-	354	354
2012				-	454	454
2013				-		
2014				-		
2015				-		
2016				-		
2017				-		
2018				-		
2019				-		
2020				-		
2021				-		
2022				-		
2023				-		
2024				-		
2025				-		

Table created May 2011, major modifications August 2012

TABLE NO. 2

DELIVERIES MADE BY CITY OF RIVERSIDE IRRIGATION DIVISION
 FROM THE RIVERSIDE CANAL TO AREAS
 WHICH ARE NOT TRIBUTARY TO THE RIVERSIDE NARROWS
 (All Quantities are in Acre Feet)

Line #	DELIVERY LOCATION	1959-63 Base Period Average	1971	1972	1973	1974	1975	1976	1977	1978	1979	1980
1	Delivery to Lower Canal Section	12,016	8,471	7,538	1,357	1,371	1,963	1,165	607	244	221	254
2	Less Adjustment for Temescal Delivery	-196	162	226	0	0	0	0	0	0	0	0
3	Total Delivery from Lower Canal Section	11,820	8,309	7,312	1,357	1,371	1,963	1,165	607	244	221	254
4	Less Deliveries to Temescal Water Co. from Lower Canal Section	7,778	6,484	5,846	0	0	0	0	0	0	0	0
5	Deliveries to Riverside Water Co. Stock & contract water from Lower Canal Section	4,042	1,825	1,466	1,357	1,371	1,963	1,165	607	244	221	254
6	Plus Deliveries from Upper Canal Section below Riverside Narrows	33	41	37	13	16	18	16	2	0	1	1
7	Total Deliveries by City of Riverside Irrigation Division not Tributary to the Riverside Narrows	4,075	1,866	1,503	1,370	1,387	1,981	1,181	609	244	222	255

Note: Lines #1 & #2 from City Records.
 Line #4 from Table No. 4, Column (4).
 Line #6 from City Records.
 Quantities in parentheses (-) are negative values.
 (retyped for 1983 report 5/31/07 sem)

TABLE NO. 2

DELIVERIES MADE BY CITY OF RIVERSIDE IRRIGATION DIVISION
FROM THE RIVERSIDE CANAL TO AREAS
WHICH ARE NOT TRIBUTARY TO THE RIVERSIDE NARROWS

Line #	DELIVERY LOCATION	1959-63 Base Period Average	1981	1982	1983	1984	1985	1986	1987	1988	1989	1990
1	Delivery to Lower Canal Section	12,016	272	0	-	-	-	-	-	-	-	-
2	Less Adjustment for Temescal Delivery	-196	0	0	-	-	-	-	-	-	-	-
3	Total Delivery from Lower Canal Section	11,820	272	0	-	-	-	-	-	-	-	-
Lower canal section abandoned, Table no longer needed												
4	Less Deliveries to Temescal Water Co. from Lower Canal Section	7,778	0	0	-	-	-	-	-	-	-	-
5	Deliveries to Riverside Water Co. Stock & contract water from Lower Canal Section	4,042	272	0	-	-	-	-	-	-	-	-
6	Plus Deliveries from Upper Canal Section below Riverside Narrows	33	1	0	-	-	-	-	-	-	-	-
7	Total Deliveries by City of Riverside Irrigation Division not Tributary to the Riverside Narrows	4,075	273	0	-	-	-	-	-	-	-	-

Note: Lines #1 & #2 from City Records.
 Line #4 from Table No. 4, Column (4).
 Line #6 from City Records.

TABLE NO. 3

page 1 of 2

DELIVERIES MADE BY THE GAGE CANAL COMPANY
TO AREAS WHICH ARE NOT TRIBUTARY
TO THE RIVERSIDE NARROWS

Calendar Year	Deliveries to Gage Stockholders (1)	Losses in Arlington Basin (2)*	Net into Mockingbird Lake (3)	Total Gage Delivery (5)
1959-63 Base Period Average	15,855	347	107	16,711
1971	17,113	(42)	(57)	17,014
1972	15,328	(16)	1,317	16,629
1973	13,144	(298)	(11)	12,835
1974	14,233	(330)	234	14,137
1975	14,370	1,007	372	15,749
1976	14,553	793	277	15,623
1977	14,533	(104)	181	14,610
1978	11,572	(102)	89	11,559
1979	12,560	(63)	(172)	12,325
1980	14,191	351	(278)	14,264
1981	11,347	239	237	11,823
1982	8,616	288	(127)	8,777
1983	8,731	549	(72)	9,208
1984	15,439	912	(12)	16,339
1985	12,326	981	46	13,353
1986	13,314	937	(134)	14,117
1987	9,388	842	(7)	10,223
1988	13,856	1,275	(93)	15,038
1989	13,216	1,806	(295)	14,727
1990	10,620	2,136	110	12,866
1991	15,734	1,579	148	17,461
1992	8,791	1,308	475	10,574
1993	9,776	792	357	10,925
1994	11,787	1,761	61	13,609
1995	10,771	1,270	187	12,228

Column (5) = Column (1) + (2) + (3).

Base period table has Column (4) which is titled "2/3 of Weir No. 2 Chart & Calculated Flow" with a 5 yr average of 402 AF. Quantities in parentheses are negative values, net gain to the Canal from storm flow into Mockingbird Canyon Lake.

Deliveries shown in Column (1) above are those made to the lands of shareholders in areas which are not tributary to the Riverside Narrows.

* Since the canal was converted to a pipeline from the headworks to about Weir No. 2 in 1975, the canal losses in the Arlington Basin are assumed to equal 2/3 of the total loss. Previous to 1975, the losses were assumed to occur equally along the entire canal, half above Weir No. 2 and half below.

Data is from the Gage Canal Company Records.

Export from the basin is the deliveries to the stockholder plus net increase storage in Mockingbird (lake is export) plus the losses that are also outside the basin.

DELIVERIES MADE BY THE GAGE CANAL COMPANY
TO AREAS WHICH ARE NOT TRIBUTARY
TO THE RIVERSIDE NARROWS

Calendar Year	Deliveries to Gage Stockholders	Losses in Arlington Basin	Net into Mockingbird Lake	Total Gage Delivery
	(1)	(2)*	(3)	(5)
1959-63 Base Period Average	15,855	347	107	16,711
1996	11,186	1,539	196	12,921
1997	12,094	641	234	12,969
1998	9,897	916	39	10,852
1999	13,727	1,346	7	15,080
2000	11,691	1,981	3	13,675
2001	10,022	1,780	37	11,839
2002	10,192	1,990	13	12,195
2003	8,236	1,898	-119	10,015
2004	8,396	837	131	9,364
2005	7,656	485	37	8,178
2006	7,881	680	-97	8,464
2007	7,601	3	-148	7,456
2008	6,849	308	-36	7,121
2009	7,153	347	-180	7,320
2010	6,930	830	-12	7,748
2011	7,906	870	125	8,901
2012	7,964	1,064	239	9,267
2013				
2014				
2015				
2016				
2017				
2018				
2019				
2020				
2021				
2022				
2023				
2024				
2025				

Column (5) = Column (1) + (2) + (3).

Quantities in parentheses are negative values, net gain to the Canal.
Deliveries shown in Column (1) above are those made to the lands of shareholders
in areas which are not tributary to the Riverside Narrows.

* Since the canal was converted to a pipeline from the headworks to about Weir No. 2 in 1975, the canal losses
in the Arlington Basin are assumed to equal 2/3 of the total loss. Previous to 1975, the losses
were assumed to occur equally along the entire canal, half above Weir No. 2 and half below.

It was further assumed that 2/3 of the lower canal losses occurred in the Arlington Basin.

Data is from the Gage Canal Company Records.

Export from the basin is the deliveries to the stockholder plus net increase storage in Mockingbird (lake is export)
plus the losses that are also outside the basin.

TABLE NO. 4

DELIVERIES BY CITY OF RIVERSIDE IRRIGATION DIVISION
FROM THE RIVERSIDE CANAL FOR USE ON LANDS
NOT TRIBUTARY TO THE RIVERSIDE NARROWS

(All Quantities are in Acre Feet)

Calendar Year	Inch Rate Contract Water Delivery to Temescal Wtr.	Carrying Rights (Mt. Vernon) Meter Delivered to Temescal	Carrying Right for Delivery to Temescal	Total Delivery to Temescal by Riverside Irrigation Div.
	(1)	(2)	(3)	(4)
1959-63 Base Period Average	5,426	2,352		7,778
1971	3,566	1,652	1,266	6,484
1972	3,183	1,459	1,204	5,846
1973	-	-	-	-
1974	-	-	-	-
1975	-	-	-	-
1976	-	-	-	-
1977	-	-	-	-
1978	-	-	-	-
1979	-	-	-	-
1980	-	-	-	-
1981	-	-	-	-
1982	-	-	-	-
1983	-	-	-	-
1984	-	-	-	-
1985	-	-	-	-
1986	-	-	-	-
1987	-	-	-	-
1988	-	-	-	-
1989	-	-	-	-
1990	-	-	-	-

Lower canal section abandoned, Table no longer needed

Notes: Columns (1), (2), and (3) are from City of Riverside Records.
 Temescal Water Company discontinued receiving their irrigation water delivery from the Riverside Canal in calendar year 1973, and began taking all their water delivery from the Gage Canal.

DELIVERIES BY GAGE CANAL COMPANY
FOR USE ON LANDS NOT TRIBUTARY
TO THE RIVERSIDE NARROWS

(All Quantities are in Acre Feet)

Calendar Year	Gage Canal Delivery to Alta Mesa	Gage Canal Delivery to Temescal Wtr. Co.	Total Delivery to Alta Mesa & Temescal by Gage Canal Co.
1959-63 Base Period Average	400	5,051	5,451
1971	278	1,433	1,711
1972	143	2,581	2,724
1973	65	4,226	4,291
1974	38	4,629	4,667
1975	45	4,666	4,711
1976	20	6,828	6,848
1977	16	3,986	4,002
1978	16	3,996	4,012
1979	21	5,549	5,570
1980	21	6,189	6,210
1981	18	5,956	5,974
1982	13	4,677	4,690
1983	11	3,288	3,299
1984	18	5,877	5,895
1985	14	4,724	4,738
1986	14	5,403	5,417
1987	13	5,487	5,500
1988	17	5,395	5,412
1989	18	5,289	5,307
1990	16	3,041	3,057
1991	17	4,706	4,723
1992	14	3,481	3,495
1993	15	3,234	3,249
1994	17	1,853	1,870
1995	16	1,012	1,028

Notes: Data from Gage Canal Company Records

DELIVERIES BY GAGE CANAL COMPANY
FOR USE ON LANDS NOT TRIBUTARY
TO THE RIVERSIDE NARROWS

(All Quantities are in Acre Feet)

Calendar Year	Gage Canal Delivery to Alta Mesa	Gage Canal Delivery to Temescal Wtr. Co.	Total Delivery to Alta Mesa & Temescal by Gage Canal Co.
1959-63 Base Period Average	400	5,051	5,451
1996	16	962	978
1997	18	1,004	1,022
1998	17	459	476
1999	23	966	989
2000	21	1,101	1,122
2001	20	336	356
2002	24	70	94
2003	19	85	104
2004	14	4	18
2005	10	1	11
2006	10	0	10
2007	10	0	10
2008	9	0	9
2009	9	0	9
2010	10	0	10
2011	10	0	10
2012	11	0	11
2013			
2014			
2015			
2016			
2017			
2018			
2019			
2020			
2021			
2022			
2023			
2024			
2025			

Notes: Data from Gage Canal Company Records

SUMMARY OF DELIVERIES MADE BY
MEEKS & DALEY WATER COMPANY, AGUA MANSA WATER COMPANY
AND TEMESCAL WATER COMPANY
INCLUDING WATER RECEIVED FROM CITY OF RIVERSIDE
FROM THE RIVERSIDE AND GAGE CANALS
TO AREAS WHICH ARE NOT TRIBUTARY TO THE RIVERSIDE NARROWS
 (All Quantities are in Acre Feet)

Calendar Year	Total Delivery to Temescal by City of Riverside Irrigation Division	Total Delivery to Alta Mesa & Temescal by Gage Canal Co.	Total Delivery by City of Riverside Irrigation Division & Gage Canal to Lands Not Tributary to the Riverside Narrows
	(1)	(2)	(3)
1959-63 Base Period Average	7,778	5,451	13,229
1971	6,484	1,711	8,195
1972	5,846	2,724	8,570
1973	- *	4,291	4,291
1974	-	4,667	4,667
1975	-	4,711	4,711
1976	-	6,848	6,848
1977	-	4,002	4,002
1978	-	4,012	4,012
1979	-	5,570	5,570
1980	-	6,210	6,210
1981	-	5,974	5,974
1982	-	4,690	4,690
1983	-	3,299	3,299
1984	-	5,895	5,895
1985	-	4,738	4,738
1986	-	5,417	5,417
1987	-	5,500	5,500
1988	-	5,412	5,412
1989	-	5,307	5,307
1990	-	3,057	3,057
1991	-	4,723	4,723
1992	-	3,495	3,495
1993	-	3,249	3,249
1994	-	1,870	1,870
1995	-	1,028	1,028

Notes: Column (1) from City of Riverside Records and Column (2) from Table 5.

* Temescal Water Company discontinued receiving their irrigation water delivery from the Riverside Canal in calendar year 1973, and began taking all of the water delivery from the Gage Canal.

TABLE NO. 6

SUMMARY OF DELIVERIES MADE BY
MEEKS & DALEY WATER COMPANY, AGUA MANSA WATER COMPANY
AND TEMESCAL WATER COMPANY
INCLUDING WATER RECEIVED FROM CITY OF RIVERSIDE
FROM THE RIVERSIDE AND GAGE CANALS
TO AREAS WHICH ARE NOT TRIBUTARY TO THE RIVERSIDE NARROWS
 (All Quantities are in Acre Feet)

Calendar Year	Total Delivery to Temescal by City of Riverside Irrigation Division (1)	Total Delivery to Alta Mesa & Temescal by Gage Canal Co. (2)	Total Delivery by City of Riverside Irrigation Division & Gage Canal to Lands Not Tributary to the Riverside Narrows (3)
1959-63 Base Period Average	7,778	5,451	13,229
1996	-	978	978
1997	-	1,022	1,022
1998	-	476	476
1999	-	989	989
2000	-	1,122	1,122
2001	-	356	356
2002	-	94	94
2003	-	104	104
2004	-	18	18
2005	-	11	11
2006	-	10	10
2007	-	10	10
2008	-	9	9
2009	-	9	9
2010	-	10	10
2011	-	10	10
2012	-	11	11
2013	-		
2014	-		
2015	-		
2016	-		
2017	-		
2018	-		
2019	-		
2020	-		
2021	-		
2022	-		
2023	-		
2024	-		
2025	-		

Notes: Column (1) from City of Riverside Records and Column (2) from Table 5.

* Temescal Water Company discontinued receiving their irrigation water delivery from the Riverside in calendar year 1973, and began taking all of the water delivery from the Gage Canal.

TABLE NO. 6A

SUMMARY OF DELIVERIES MADE BY
 MECKS & DALEY WATER COMPANY
 FROM CITY OF RIVERSIDE WATER SYSTEM
 TO WESTERN MUNICIPAL WATER DISTRICT
 TO AREAS WHICH ARE NOT TRIBUTARY TO THE RIVERSIDE NARROWS

(All Quantities are in Acre Feet)

Calendar Year	Delivery to WMWD Non-Potable Pump Station from the Riverside Canal at Jefferson Street (1)	Delivery by City of Riverside Domestic System at Mockingbird Canyon of M&D Water (2)	Delivery by City of Riverside Domestic System at Warmington of M&D Water (3)	Canal operational spills at Monroe Street Storm Drain (4)	Total Delivery by City of Riverside of Meeks & Daley water to WMWD Not Tributary to the Narrows (5)
1996		1,481	0		1,481
1997		0	0		0
1998		217	0		217
1999		285	0		285
2000		42	0		42
2001		11	0		1,772
2002		3,047	358		5,087
2003		3,879	59		5,168
2004	1,761	4,327	13		5,463
2005	1,682	2,400	0		3,710
2006	1,230				
2007	1,123				
2008	1,310				
2009					
2010					
2011					
2012					
2013					
2014					
2015					
2016					
2017					
2018					
2019					
2020					
2021					
2022					
2023					
2024					
2025					

Table created 08/17/12 by S.Mains to record WMWD/M&D 9cfs lease agreement
 Column (1) = Data provided by WMWD of water taken from the Riverside Canal at Jefferson Street pump station
 Column (2) = Data from City of Riverside Water production report, WMWD Mock-Can Del, system # 9212
 Column (3) = Data from City of Riverside Water production report, WMWD Warmington Can Del- system # 9200
 Column (4) = Reserved for future connection
 Column (5) = sum of Column 1 thru 4

WMWD = Western Municipal Water District
 M&D = Meeks & Daley

TABLE NO. 7

WEST RIVERSIDE CANAL COMPANY
 DELIVERIES MADE TO LATERALS #3 & #2
 FOR USE IN GLEN AVON & PEDLEY AREAS
 ON AREAS NOT TRIBUTARY TO THE RIVERSIDE NARROWS

(All Quantities are in Acre Feet)

Calendar year	La Sierra Water Co. (2)	Agua Mansa Water Co. (3)	Water Delivered to Lateral #3 & #2			Twin Buttes Water Co. (7)	Total Deliveries (8)
			Salazar Water Co. (4)	350 Inch Water Co. (5)	Jurupa Water Co.* (6)		
1959-63 Base Period Average	1,663	687	62	808	763	920	4,903
1971	2,619	485	23	771	1,220	834	5,952
1972	3,396	249	25	682	1,032	72	5,456
1973	2,162	201	21	541	785	0	3,710
1974	2,673	359	0	825	1,012	0	4,869
1975	1,823	384	-	845	906	917	4,875
1976	1,770	318	-	778	1,004	759	4,629
1977	1,281	242	-	742	957	C	3,222
1978	850	125	-	223	783	C	1,981
1979	993	155	-	376	1,183	C	2,707
1980	1,001	135	-	420	950	C	2,506
1981	949	220	-	1,395	582	C	3,146
1982	175	62	-	220	649	C	1,106
1983	121	42	-	134	520	0	817
1984	200	81	-	203	676	0	1,160
1985	144	36	-	162	603	0	945
1986	129	31	-	139	382	0	681
1987	131	26	-	83	419	12	671
1988	224	36	-	80	278	1,199	1,817
1989	93	30	-	55	248	407	833
1990	41 **	23	-	70	392	355	881
1991	-	0	-	45	646	0	691
1992	-	0	-	25	357	0	382
1993	-	0	-	0	236	0	236
1994	-	0	-	0	236	0	236
1995	-	0	-	0	185	0	185

* Jurupa Community Services District (JCS D) purchased the Jurupa Water Company and uses JCS D Sunnyslope Wells 3 & 5 to make JWC deliveries after Nov. 1 1988.
 ** La Sierra Water Company went out of the water delivery business on June 1, 1990.
 Columns (2), (3), & (5) are from West Riverside Canal Company Records.
 Columns (6) are from Recordation Filing, 3600535- for Jurupa Water Company #3.
 Columns (7) from Recordation Filing, 3600898- for Twin Buttes Water Co. (C of R Twin Buttes #6).
 Conversion factor used is 0.03967 af/mid.

TABLE NO. 7

WEST RIVERSIDE CANAL COMPANY
 DELIVERIES MADE TO LATERALS #3 & #2
 FOR USE IN GLEN AVON & PEDLEY AREAS
 ON AREAS NOT TRIBUTARY TO THE RIVERSIDE NARROWS
 (All Quantities are in Acre Feet)

Calendar Year	La Sierra Water Co.		Agua Mansa Water Co.		Salazar Water Co.		350 Inch Water Co.		Jurupa Water Co.*		Twin Buttes Water Co.		Empire Water		Total Deliveries (8)
	(2)	3	(4)	(4)	(5)	(5)	(6)	(6)	(7)	(7)	(A)	(A)	(B)		
1959-63 Base	1,663	687	62	808	763	920	-	-	-	-	-	-	-	-	4,903
1996	-	0	-	0	0	0	0	0	0	0	0	0	0	0	0
1997	-	0	-	0	0	0	0	0	0	0	0	0	0	0	0
1998	Canal no longer operable from the Colton/Riverside North Basins														
1999	-	-	-	-	-	-	-	-	-	-	-	-	-	-	0
2000	-	-	-	-	-	-	-	-	-	-	-	-	-	-	0
2001	-	-	-	-	-	-	-	-	-	-	-	-	-	-	0
2002	-	-	-	-	-	-	-	-	-	-	-	-	-	-	0
2003	-	-	-	-	-	-	-	-	-	-	-	-	-	-	0
2004	-	-	-	-	-	-	-	-	-	-	-	-	-	-	0
2005	-	-	-	-	-	-	-	-	-	-	-	-	-	-	221
2006	-	-	-	-	-	-	-	-	-	-	-	-	-	-	487
2007	-	-	-	-	-	-	-	-	-	-	-	-	-	-	515
2008	-	-	-	-	-	-	-	-	-	-	-	-	-	-	563
2009	-	-	-	-	-	-	-	-	-	-	-	-	-	-	575
2010	-	-	-	-	-	-	-	-	-	-	-	-	-	-	533
2011	-	-	-	-	-	-	-	-	-	-	-	-	-	-	475
2012	-	-	-	-	-	-	-	-	-	-	-	-	-	-	456
2013	-	-	-	-	-	-	-	-	-	-	-	-	-	-	503
2014	-	-	-	-	-	-	-	-	-	-	-	-	-	-	-
2015	-	-	-	-	-	-	-	-	-	-	-	-	-	-	-
2016	-	-	-	-	-	-	-	-	-	-	-	-	-	-	-
2017	-	-	-	-	-	-	-	-	-	-	-	-	-	-	-
2018	-	-	-	-	-	-	-	-	-	-	-	-	-	-	-
2019	-	-	-	-	-	-	-	-	-	-	-	-	-	-	-
2020	-	-	-	-	-	-	-	-	-	-	-	-	-	-	-
2021	-	-	-	-	-	-	-	-	-	-	-	-	-	-	-
2022	-	-	-	-	-	-	-	-	-	-	-	-	-	-	-
2023	-	-	-	-	-	-	-	-	-	-	-	-	-	-	-
2024	-	-	-	-	-	-	-	-	-	-	-	-	-	-	-
2025	-	-	-	-	-	-	-	-	-	-	-	-	-	-	-

* Jurupa Community Services District (JCSD) purchased the Jurupa Water Company and uses JCSD Sunnyslope Wells 3 & 5 to make JWC deliveries after Nov. 1 1988.

** La Sierra Water Company went out of the water delivery business on June 1, 1990.

Columns (2), (3), & (5) are from West Riverside Canal Company Records.

Columns (6) are from Recordation Filing, 3600535- for Jurupa Water Company #3.

Columns (7) from Recordation Filing, 3600898- for Twin Buttes Water Co. (C of R Twin Buttes #6).

Columns (7A) new exporter starting in 2004 (recordation # 3302979 & 2980) export to Chino Basin

2007 Indian Hills Water Conservation Corp purchased by Empire Water

Conversion factor used is 0.03967 af/mid.

TABLE NO. 8

NOT REQUIRED AFTER 1968

WEST RIVERSIDE CANAL COMPANY COMPARISON OF WATER
DELIVERED TO CANAL BY WATER COMPANIES WITH CANAL COMPANY
RECORDS OF WATER RECEIVED AND CALCULATED CANAL LOSSES

TABLE NO. 9

DELIVERIES MADE BY
JURUPA COMMUNITY SERVICES DISTRICT
TO AREAS WHICH ARE NOT TRIBUTARY TO THE
RIVERSIDE NARROWS

(All Quantities are in Acre Feet)

Local Designation Recordation # State Well #	Sunnyslope #3 #3301362 2S5W08G04S	Sunnyslope #5 #3301501 2S5W08G01S	Sunnyslope #6 #3301502 2S5W08K02S	Sunnyslope #7 #3301625 2S5W08K03S	Well #21 #3302911 2S5W08G05S	Deliveries in the Riverside Basin	Total Export from the Riverside Basin Area
	(1)	(2)	(3)	(4)	(4a)	(5)	(6)
1959-c3 Base Period Average							531
Year							
1971	223	517	54	C			794
1972	288	516	3	C			807
1973	201	339	5	C			545
1974	223	322	21	C			566
1975	229	411	C	C			64C
1976	268	597	C	C			865
1977	231	542	C	C			773
1978	199	411	C	C			61C
1979	184	366	C	C			55C
1980	0	3	C	C			3
1981	0	C	-	-			C
1982	0	C	-	-			C
1983	0	0	-	-			0
1984	52	475	-	-			527
1985	266	634	-	-			900
1986	70	475	-	-			545
1987	0	C	-	-			C
1988	1	C	-	-			1
1989	397	C	-	-			397
1990	310	C	-	-		33	277
1991	203	C	-	-		0	203
1992	242	C	-	-		0	242
1993	278	C	-	-		0	278
1994	236	C	-	-		0	236
1995	266	C	-	-		0	266

Prior to 1968, these wells were owned by Rubidoux Community Services District.
 Sunnyslope #6 & #7 were abandoned in 1981. Sunnyslope #3 casing collapsed & well abandoned in 2000.
 Beginning in 1988, the Sunnyslope Wells were being used to deliver water for the Jurupa Water Company Shareholders.

DELIVERIES MADE BY
JURUPA COMMUNITY SERVICES DISTRICT
TO AREAS WHICH ARE NOT TRIBUTARY TO THE
RIVERSIDE NARROWS

(All Quantities are in Acre Feet)

Local Designation Recordation # State Well #	Sunnyslope #3 #3301362 2S5W08G04S	Sunnyslope #5 #3301501 2S5W08G01S	Sunnyslope #6 #3301502 2S5W08K02S	Sunnyslope #7 #3301625 2S5W08K03S	Well #21 #3302911 2S5W08G05S	Deliveries in the Riverside Basin (5)	Total Export from the Riverside Basin Area (6)
1959-63 Base Period Average	531						
Year							
1996	236	0	-	-	-	0	236
1997	0	37	-	-	-	0	37
1998	0	28	-	-	-	28 *	0
1999	0	203	-	-	-	203 *	0
2000	-	1	-	-	571	572 *	0
2001	-	0	-	-	707	707 *	0
2002	-	0	-	-	703	703 *	0
2003	-	217	-	-	541	758 *	0
2004	-	0	-	-	563	563 *	0
2005	-	251	-	-	472	723 *	0
2006	-	0	-	-	559	559 *	0
2007	-	0	-	-	587	587 *	0
2008	-	0	-	-	603	603 *	0
2009	-	0	-	-	581	581 *	0
2010	-	1	-	-	401	402 *	0
2011	-	1	-	-	508	509 *	0
2012	-	47	-	-	485	532 *	0
2013	-	-	-	-	-	-	-
2014	-	-	-	-	-	-	-
2015	-	-	-	-	-	-	-
2016	-	-	-	-	-	-	-
2017	-	-	-	-	-	-	-
2018	-	-	-	-	-	-	-
2019	-	-	-	-	-	-	-
2020	-	-	-	-	-	-	-
2021	-	-	-	-	-	-	-
2022	-	-	-	-	-	-	-
2023	-	-	-	-	-	-	-
2024	-	-	-	-	-	-	-
2025	-	-	-	-	-	-	-

Prior to 1968, these wells were owned by Rubidoux Community Services District.

Sunnyslope #6 & #7 were abandoned in 1981. Sunnyslope #3 casing collapsed & well abandoned in 2000.

Beginning in 1988, the Sunnyslope Wells were being used to deliver water for the Jurupa Water Company Shareholders.

* In 1999, JCS D started making non-potable deliveries to the Quarry Hills Golf Course which is located in Riverside South Basin

TABLE NO. 10

DELIVERIES MADE BY RUBIDOUX COMMUNITY SERVICES DISTRICT *
TO AREAS WHICH ARE NOT TRIBUTARY TO THE RIVERSIDE NARROWS

(All Quantities are in Acre Feet)

Calendar Year	Total Number of Metered Connections (1)	Annual Water Productions Per Meter (A.F./Meter) (2)	Total Water Production Delivered (3)	Delivery to Boise Cascade Mobile Home Park (4)	Total Water Delivered to Chino Basin (5)	Flow returned to sewer (40% of Total Delivery) (6)	Total Export from Riverside Basin Area (7)
1959-63 Base Period Average					298	118	180
1971	89	0.85	76	16	92	37	55
1972	89	0.85	76	32	108	43	65
1973	111	0.85	94	44	138	55	83
1974	127	0.85	108	35	143	57	86
1975	130	0.85	111	45	156	62	93
1976	181	0.85	154	53	207	83	124
1977	232	0.85	197	62	259	104	156
1978	322	0.85	274	81	355	142	213
1979	407	0.85	346	60	406	162	244
1980	407	0.85	346	78	424	170	254
1981	407	0.85	346	88	434	174	260
1982	407	0.85	346	74	420	168	252
1983	407	0.85	346	114	460	184	276
1984	407	0.85	346	180	526	210	316
1985	407	0.85	346	194	540	216	324
1986	407	0.85	346	200 1)	546	218	328
1987	407	0.85	346	64 2)	410	164	246
1988	407	0.85	346	99	445	178	267
1989	407	0.85	346	98	444	178	266
1990	407	0.85	346	67	413	165	248
1991	407	0.85	346	76	422	169	253
1992	407	0.85	346	57	403	161	242
1993	407	0.85	346	81	427	171	256
1994	407	0.85	346	70 3)	416	166	250
1995	407	0.85	346	70 3)	416	166	250

Notes:
 Column (3) = Column (1) x Column (2)
 Column (5) = Column (3) + Column (4)
 Column (6) = Column (5) x 40%
 Column (7) = Column (5) - Column (6)
 * Area was served by Jurupa Hills Water Company prior to 1968.
 1) In 1986 individual meters were installed, flow estimated.
 2) Mobile Home Park now on individual meters.
 3) Mobile Home Park uses estimated at 0.22 af/du * 319 units

TABLE NO. 10

DELIVERIES MADE BY RUBIDOUX COMMUNITY SERVICES DISTRICT *
TO AREAS WHICH ARE NOT TRIBUTARY TO THE RIVERSIDE NARROWS

(All Quantities are in Acre Feet)

Calendar Year	Total Number of Metered Connections (1)	Annual Water Productions Per Meter (A.F./Meter) (2)	Total Water Production Delivered (3)	Delivery to Boise Cascade Mobile Home Park (4)	Total Water Delivered to Chino Basin (5)	Flow returned to sewer 40% of Total Delivery (6)	Subtotal Retail deliveries to JCSD (6a)	Wholesale Deliveries to JCSD (6b)	Irrigation Deliveries to Jurupa Hills Golf Course (6c)	Total Export from Riverside Basin Area (7)
1959-63 Base Period Average			298		298	118				180
1996	527 1)	0.85 2)	448	120 3)	568	227	341			341
1997	527 1)	0.85 2)	448	120 3)	568	227	341			341
1998	527 1)	0.85 2)	448	120 3)	568	227	341			341
1999	527 1)	0.85 2)	448	120 3)	568	227	341			341
2000	527 1)	0.85 2)	448	120 3)	568	227	341	457		798
2001	527 1)	0.85 2)	448	120 3)	568	227	341	766		1,107
2002	527 1)	0.85 2)	448	120 3)	568	227	341	0		341
2003	527 1)	0.85 2)	448	120 3)	568	227	341	157		498
2004	527 1)	0.85 2)	448	120 3)	568	227	341	132		473
2005	527 1)	0.85 2)	448	120 3)	568	227	341	94		435
2006	527 1)	0.85 2)	448	120 3)	568	227	341	203		544
2007	527 1)	0.85 2)	448	120 3)	568	227	341	367		708
2008	527 1)	0.85 2)	448	120 3)	568	227	341	171	386 4)	512
2009	527 1)	0.85 2)	448	120 3)	568	227	341	480	286	821
2010	527 1)	0.85 2)	448	118 3) 5)	566	226	340	743	338	1,083
2011	527 1)	0.85 2)	448	122 3) 5)	570	228	342	808	354	1,150
2012	527 1)	0.85 2)	448	126 3) 5)	574	230	344	702	406	1,046
2013										
2014										
2015										
2016										
2017										
2018										
2019										
2020										
2021										
2022										
2023										
2024										
2025										

Notes:

- Column (3) = Column (1) x Column (2)
 - Column (5) = Column (3) + Column (4)
 - Column (6) = Column (5) x 40%
 - 40% is the average of 2001-2011 RCSD wastewater to Riverside/RCSD consumption
 - Column 6a = From RSD records - Column added during 2010 verification
 - Column 6a = Column 5 - Column 6
 - Column (6b) added during 2010 Verification
 - Column (6c) added during 2011 Verification
 - Column (7) = Column (5) - Column (6)
 - Column 7 = Column 6a + Column 6b + Column 6c
- * Area was served by Jurupa Hills Water Company prior to 1968.
- 1) During 2011 verification received new water service count
 - 2) 0.85 AF/DU RCSD concus is a reasonable use
 - 3) Mobile Home Park uses estimated at 0.37 af/du * 325 units for 1996-2007
 - 4) Starting in 2008 from RCSD non-potable system account # 1502301000
 - 5) Starting in 2010 report, actual water meter deliver to the Park

SECTION II

CREDIT FOR RETURN FLOW
RESULTING FROM DELIVERY OF IMPORTED WATER IN
AREAS TRIBUTARY TO THE RIVERSIDE NARROWS

Pursuant to Judgment Paragraph XI(b)3 Western receives against any future replenishment obligations for any return flow from imported water used in Riverside County which contributes to base flow at Riverside Narrows. In addition, Judgment Paragraph XI(a) provides that the credit for return flow will be the calculated amount of return flow adjusted upward or downward depending on the quality (TDS) of the return flow, using the same quality adjustment formula used at Riverside Narrows in the Orange County Judgment.¹

There are currently two methods of delivering imported water in Riverside County to areas tributary to Riverside Narrows.

- 1) Direct delivery to Western's retail service area and to the City of Riverside (WR-24C) of water from the Henry J. Mills Treatment Plant which treats State Water Project water.

- 2) Delivery to Western, or any Plaintiff party, of ground water from the San Bernardino Basin Area pursuant to the 2004 Judgment Paragraph VI(b)6 Agreement that provides for 6000 AF of additional water extraction in exchange for Western's purchase of a like amount of recharge water.

Volume 6, Table No. 11, shows the return flow from imported water delivered by both Western and the City of Riverside to areas tributary to the Riverside Narrows for the calendar years 1971 through 2012. Water quality adjustments have been made in the table.

The following information is intended to complement Table No. 11 data and help the reader understand its mechanics.

For calendar years 1971 through 1991, no source data is available. The only information available is the amounts indicated in Table No. 16 on the row titled *Return from Imported Water* published in Watermaster Annual Reports prior to April 1, 2014. This information is included at the bottom of Table No. 11 in the row titled *Quality Adjusted Return Flow Resulting from Imported Water Delivered to Areas Tributary to the Narrows*.

For all calendar years after 1991, the table row titled *Total Deliveries of Imported Water* lists the sum of all imported water delivered directly by Western and the City of Riverside, both to agricultural and domestic water users, within areas tributary to the Riverside Narrows (method 1 defined above). Pursuant to the 2004 Judgment Paragraph VI(b)6 Agreement that provides for additional water extractions in the San Bernardino Basin Area in exchange for Western's purchase of a like amount of imported recharge water, when applicable, *Imported Water Recharged in and Extracted from the San Bernardino Basin Area* is added to the *Total Deliveries of Imported Water*. (method 2 defined above). As of the writing of this report, such an extraction has occurred only once, in 2007, and is recorded in Table No. 11.

For calendar years after 1991, *Imported Water Return Flow Tributary to Narrows* is calculated as thirty-six (36) percent of *Total Deliveries of Imported Water* to areas tributary to the Riverside Narrows.

For all years for which supporting data for calculations are available (1992 through present), Western and the City of Riverside received direct delivery of imported water through Metropolitan Water District's Henry J. Mills Treatment Plant (Mills Plant) on Alessandro Boulevard in Riverside. The TDS levels at the Mills Plant are listed for each calendar year on the row titled *TDS of Delivered Water (mg/L)*. This information is used in the calculation to determine the

TDS of Return Flow from Delivered Water (mg/L) and the Amount of Adjustment Based on Quality of Imported Water.

Calculating the TDS of Return Flow from Delivered Water

For the purposes of calculating the *TDS of Return Flow from Delivered Water*, it is assumed that sixty-five (65) percent of *Total Deliveries of Imported Water* is applied to the land in areas tributary to the Riverside Narrows. 65-percent is considered reasonable by the Western-San Bernardino Watermaster based on analysis of actual customer water use in Western's retail water service area. To complete the determination of the concentration of salts in return flows to the Narrows, the ratio of *Total Deliveries of Imported Water* to *Imported Water Return Flow Tributary to Narrows* is multiplied by the *TDS of Delivered Water (mg/L)*.

The formula used is:

$$\text{Salt in Water Applied Outdoors} = \text{Salt in Return Flow}$$

TDS of Return Flow from Delivered Water (mg/L) =

$$\frac{(0.65 * \text{Total Deliveries of Imported Water} * \text{TDS of Delivered Water})}{\text{Imported Water Return Flow Tributary to Narrows}}$$

Calculating Amount of Adjustment Based on Quality of Imported Water

The calculation of the *TDS of Return Flow from Delivered Water (mg/L)* can result in three scenarios:

1. TDS value greater than 700 mg/L;
2. TDS value greater than 600 mg/L but less than 700 mg/L; or,
3. TDS value less than 600 mg/L.

A TDS value greater than 700 mg/L, will result in a debit that is subtracted from the *Imported Water Return Flow Tributary to Narrows*.

A TDS value greater than 600 mg/L but less than 700 mg/L will result in neither a credit being added to nor a debit being subtracted from the *Imported Water Return Flow Tributary to Narrows*. A TDS value less than 600 mg/L, will result in a credit that is added to the *Imported Water Return Flow Tributary to Narrows*.

The formula for the *Amount of Adjustment Based on Quality of Imported Water* is:

If the TDS is:	Then the <i>Quality Adjusted Return Flow Resulting from Imported Water Delivered to Areas Tributary to the Narrows</i> is determined by the formula¹ below
Greater than 700	$11 * \frac{\text{Imported Water Return Flow Tributary to Narrows}}{15,250} * (\text{TDS} - 700)$
600 to 700	<i>Imported Water Return Flow Tributary to Narrows</i>
Less Than 600	$11 * \frac{\text{Imported Water Return Flow Tributary to Narrows}}{15,250} * (600 - \text{TDS})$

The *Quality Adjusted Return Flow Resulting from Imported Water Delivered to Areas Tributary to the Narrows* is shown on the bottom line of Table No. 11.

1. Stipulated Judgment in the case of Orange County Water District v. City of Chino, et al., Case No. 117628-County of Orange, page 12.

TABLE 11
CREDIT FOR RETURN FLOW RESULTING FROM DELIVERY OF
IMPORTED WATER IN AREAS TRIBUTARY TO THE RIVERSIDE NARROWS
 (All Quantities in Acre Feet Unless Otherwise Stated)

	Calendar Year									
	1971	1972	1973	1974	1975	1976	1977	1978	1979	1980
Western Imported Domestic Water Deliveries	-	-	-	-	-	-	-	-	-	-
Western Imported Water Agricultural Deliveries	-	-	-	-	-	-	-	-	-	-
Subtotal of Western Imported Water Deliveries	-	-	-	-	-	-	-	-	-	-
City of Riverside Imported Domestic Water Deliveries	-	-	-	-	-	-	-	-	-	-
Imported Water Recharged in and Extracted from SBBA	-	-	-	-	-	-	-	-	-	-
Total Deliveries of Imported Water	-	-	-	-	-	-	-	-	-	-
Imported Water Return Flow Tributary to Narrows (at 36%)	-	-	-	-	-	-	-	-	-	-
TDS of Delivered Water (mg/L)	-	-	-	-	-	-	-	-	-	-
TDS of Return Flow from Delivered Water (mg/L)	-	-	-	-	-	-	-	-	-	-
Amount of Adjustment Based on Quality of Imported Water	-	-	-	-	-	-	-	-	-	-
Quality Adjusted Return Flow Resulting from Imported Water Delivered to Areas Tributary to the Narrows	331	345	305	346	330	358	331	255	302	398

No Data Available

- 1 Imported water delivered by Western to domestic customers in areas tributary to the Riverside Narrows.
- 2 Imported water delivered by Western to agricultural customers in areas tributary to the Riverside Narrows.
- 3 The sum of imported water delivered by Western in areas tributary to the Riverside Narrows.
- 4 Imported water purchased by the City of Riverside through MWD connection WR-24C and delivered to areas tributary to the Riverside Narrows.
- 5 Extraction of additional water by Western or any Plaintiff from the San Bernardino Basin Area made pursuant to any Judgment Paragraph VI (b) 6 Agreement that provides for extraction of additional water in exchange for Western's purchase of a like amount of imported recharge water.
- 6 The sum of all imported water deliveries to areas tributary to the Riverside Narrows.
- 7 36 percent of imported water delivered to areas tributary to the Riverside Narrows.
- 8 TDS in mg/L of State Water Project water from the Henry J Mills Treatment Plant. Prior to 1980, imported water was delivered from the Colorado River Aqueduct at Lake Mathews.
- 9 TDS (mg/L) of return flow from delivered water in areas tributary to the Riverside Narrows. TDS of return flow is greater than TDS of delivered water as a result of consumptive use.
- 10 Judgment Paragraph XI (a) provides for adjustments for water quality of imported water returned to areas tributary to the Riverside Narrows using the following formula from the Orange County Judgment: Adjustment = $[(11 * (Q/15250) * \Delta TDS)]$. In the case where the TDS of return flow is less than 600 mg/L, the quality adjustment results in a positive value. In cases where the TDS of return flow is greater than 700 mg/L, the quality adjustment results in a negative value. In cases where the TDS of return flow is greater than 600 and less than 700, no adjustment for water quality is required.
- 11 The quality adjusted return flow from delivery of imported water delivered by both Western and the City of Riverside in areas tributary to the Riverside Narrows. For calendar years 1971 through 1991, no data are available. The only information available is the amounts of Return from Imported Water published in the Watermaster Annual Reports prior to April 1, 2014 (Table No. 16).

TABLE 11

CREDIT FOR RETURN FLOWS RESULTING FROM DELIVERY OF IMPORTED WATER IN AREAS TRIBUTARY TO THE RIVERSIDE NARROWS
(All Quantities in Acre Feet Unless Otherwise Stated)

	1981	1982	1983	1984	1985	1986	1987	1988	1989	1990
Western Imported Domestic Water Deliveries	-	-	-	-	-	-	-	-	-	-
Western Imported Water Agricultural Deliveries	-	-	-	-	-	-	-	-	-	-
Subtotal of Western Imported Water Deliveries	-	-	-	-	-	-	-	-	-	-
City of Riverside Imported Domestic Water Deliveries	-	-	-	-	-	-	-	-	-	-
Imported Water Recharged in and Extracted from SBBA	-	-	-	-	-	-	-	-	-	-
Total Deliveries of Imported Water	-	-	-	-	-	-	-	-	-	-
Imported Water Return Flow Tributary to Narrows (at 36%)	-	-	-	-	-	-	-	-	-	-
TDS of Delivered Water (mg/L)	-	-	-	-	-	-	-	-	-	-
TDS of Return Flow from Delivered Water (mg/L)	-	-	-	-	-	-	-	-	-	-
Amount of Adjustment Based on Quality of Imported Water	-	-	-	-	-	-	-	-	-	-
Quality Adjusted Return Flow Resulting from Imported Water Delivered to Areas Tributary to the Narrows	458	345	303	368	533	502	505	310	380	256

- 1 Imported water delivered by Western to domestic customers in areas tributary to the Riverside Narrows.
- 2 Imported water delivered by Western to agricultural customers in areas tributary to the Riverside Narrows.
- 3 The sum of imported water delivered by Western in areas tributary to the Riverside Narrows.
- 4 Imported water purchased by the City of Riverside through MWD connection WR-24C and delivered to areas tributary to the Riverside Narrows.
- 5 Extraction of additional water by Western or any Plaintiff from the San Bernardino Basin Area made pursuant to any Judgment Paragraph VI (b) 6 Agreement that provides for extraction of additional water in exchange for Western's purchase of a like amount of imported recharge water.
- 6 The sum of all imported water deliveries to areas tributary to the Riverside Narrows.
- 7 36 percent of imported water delivered to areas tributary to the Riverside Narrows.
- 8 TDS in mg/L of State Water Project water from the Henry J Mills Treatment Plant. Prior to 1980, imported water was delivered from the Colorado River Aqueduct at Lake Mathews.
- 9 TDS (mg/L) of return flow from delivered water in areas tributary to the Riverside Narrows. TDS of return flow is greater than TDS of delivered water as a result of consumptive use.
- 10 Judgment Paragraph XI (a) provides for adjustments for water quality of imported water returned to areas tributary to the Riverside Narrows using the following formula from the Orange County Judgment: Adjustment = $[(I * (Q/15250)) * \Delta TDS]$. In the case where the TDS of return flow is less than 600 mg/L, the quality adjustment results in a positive value. In cases where the TDS of return flow is greater than 700 mg/L, the quality adjustment results in a negative value. In cases where the TDS of return flow is greater than 600 and less than 700, no adjustment for water quality is required.
- 11 The quality adjusted return flow from delivery of imported water delivered by both Western and the City of Riverside in areas tributary to the Riverside Narrows. For calendar years 1971 through 1991, no data are available. The only information available is the amounts of Return from Imported Water published in the Watermaster Annual Reports prior to April 1, 2014 (Table No. 16).

TABLE 11

CREDIT FOR RETURN FLOW RESULTING FROM DELIVERY OF IMPORTED WATER IN AREAS TRIBUTARY TO THE RIVERSIDE NARROWS
(All Quantities in Acre Feet Unless Otherwise Stated)

	1991	1992	1993	1994	1995	1996	1997	1998	1999	2000
Western Imported Domestic Water Deliveries	-	1,903	2,032	2,107	2,424	2,741	3,058	2,667	3,430	3,735
Western Imported Water Agricultural Deliveries	-	402	245	269	232	285	279	224	308	211
Subtotal of Western Imported Water Deliveries	-	2,305	2,277	2,376	2,656	3,026	3,337	2,891	3,738	3,946
City of Riverside Imported Domestic Water Deliveries	-	436	46	21	95	267	259	270	72	378
Imported Water Recharged in and Extracted from SBBA	-	-	-	-	-	-	-	-	-	-
Total Deliveries of Imported Water	-	2,741	2,323	2,397	2,751	3,293	3,596	3,161	3,810	4,324
Imported Water Return Flow Tributary to Narrows (at 36%)	-	987	836	863	990	1,185	1,295	1,138	1,372	1,557
TDS of Delivered Water (mg/L)	-	382	284	311	262	226	243	180	213	232
TDS of Return Flow from Delivered Water (mg/L)	-	690	513	561	473	408	439	325	384	419
Amount of Adjustment Based on Quality of Imported Water	-	-	52	24	91	164	150	226	214	203

Quality Adjusted Return Flow Resulting from Imported Water Delivered to Areas Tributary to the Narrows

11	221	987	888	887	1,081	1,349	1,445	1,364	1,586	1,760
----	-----	-----	-----	-----	-------	-------	-------	-------	-------	-------

- 1 Imported water delivered by Western to domestic customers in areas tributary to the Riverside Narrows.
- 2 Imported water delivered by Western to agricultural customers in areas tributary to the Riverside Narrows.
- 3 The sum of imported water delivered by Western in areas tributary to the Riverside Narrows.
- 4 Imported water purchased by the City of Riverside through MMD connection WR-24C and delivered to areas tributary to the Riverside Narrows.
- 5 Extraction of additional water by Western or any Plaintiff from the San Bernardino Basin Area made pursuant to any Judgment Paragraph VI (b) 6 Agreement that provides for extraction of additional water in exchange for Western's purchase of a like amount of imported recharge water.
- 6 The sum of all imported water deliveries to areas tributary to the Riverside Narrows.
- 7 36 percent of imported water delivered to areas tributary to the Riverside Narrows.
- 8 TDS in mg/L of State Water Project water from the Henry J. Mills Treatment Plant. Prior to 1980, imported water was delivered from the Colorado River Aqueduct at Lake Mathews.
- 9 TDS (mg/L) of return flow from delivered water in areas tributary to the Riverside Narrows. TDS of return flow is greater than TDS of delivered water as a result of consumptive use.
- 10 Judgment Paragraph XI (a) provides for adjustments for water quality of imported water returned to areas tributary to the Riverside Narrows using the following formula from the Orange County Judgment: Adjustment = $[(10/15250) * \Delta \text{TDS}]$. In the case where the TDS of return flow is less than 600 mg/L, the quality adjustment results in a positive value. In cases where the TDS of return flow is greater than 700 mg/L, the quality adjustment results in a negative value. In cases where the TDS of return flow is greater than 600 and less than 700, no adjustment for water quality is required.
- 11 The quality adjusted return flow from delivery of imported water delivered by both Western and the City of Riverside in areas tributary to the Riverside Narrows. For calendar years 1971 through 1991, no data are available. The only information available is the amounts of Return from Imported Water published in the Watermaster Annual Reports prior to April 1, 2014 (Table No. 16).

TABLE 11

CREDIT FOR RETURN FLOW RESULTING FROM DELIVERY OF IMPORTED WATER IN AREAS TRIBUTARY TO THE RIVERSIDE NARROWS
(All Quantities in Acre Feet Unless Otherwise Stated)

	2001	2002	2003	2004	2005	2006	2007	2008	2009	2010
Western Imported Domestic Water Deliveries	3,913	4,423	5,288	5,590	5,313	5,778	6,286	5,881	6,616	5,795
Western Imported Water Agricultural Deliveries	45									
Subtotal of Western Imported Water Deliveries	3,958	4,423	5,288	5,590	5,313	5,778	6,286	5,881	6,616	5,795
City of Riverside Imported Domestic Water Deliveries	983	655	1,375	3,179	3,380	2,023	1,683	1		
Imported Water Recharged in and Extracted from SBBA							2,459			
Total Deliveries of Imported Water	4,941	5,078	6,663	8,769	8,693	7,801	10,428	5,882	6,616	5,795
Imported Water Return Flow Tributary to Narrows (at 36%)	1,779	1,828	2,399	3,157	3,129	2,808	3,754	2,118	2,382	2,086
TDS of Delivered Water (mg/L)	307	295	261	292	269	200	291	314	330	290
TDS of Return Flow from Delivered Water (mg/L)	554	533	471	527	486	361	525	567	596	524
Amount of Adjustment Based on Quality of Imported Water	59	88	223	166	257	484	203	50	7	114
Quality Adjusted Return Flow Resulting from Imported Water Delivered to Areas Tributary to the Narrows	1,838	1,916	2,622	3,323	3,386	3,292	3,957	2,168	2,389	2,200

- 1 Imported water delivered by Western to domestic customers in areas tributary to the Riverside Narrows.
- 2 Imported water delivered by Western to agricultural customers in areas tributary to the Riverside Narrows.
- 3 The sum of imported water delivered by Western in areas tributary to the Riverside Narrows.
- 4 Imported water purchased by the City of Riverside through MWD connection WR-24C and delivered to areas tributary to the Riverside Narrows.
- 5 Extraction of additional water by Western or any Plaintiff from the San Bernardino Basin Area made pursuant to any Judgment Paragraph VI (b) 6 Agreement that provides for extraction of additional water in exchange for Western's purchase of a like amount of imported recharge water.
- 6 The sum of all imported water deliveries to areas tributary to the Riverside Narrows.
- 7 36 percent of imported water delivered to areas tributary to the Riverside Narrows.
- 8 TDS in mg/L of State Water Project water from the Henry J Mills Treatment Plant. Prior to 1980, imported water was delivered from the Colorado River Aqueduct at Lake Mathews.
- 9 TDS (mg/L) of return flow from delivered water in areas tributary to the Riverside Narrows. TDS of return flow is greater than TDS of delivered water as a result of consumptive use.
- 10 Judgment Paragraph XI(a) provides for adjustments for water quality of imported water returned to areas tributary to the Riverside Narrows using the following formula from the Orange County Judgment: Adjustment = $[(11 * (Q/15250) * \Delta TDS)]$. In the case where the TDS of return flow is less than 600 mg/L, the quality adjustment results in a positive value. In cases where the TDS of return flow is greater than 700 mg/L, the quality adjustment results in a negative value. In cases where the TDS of return flow is greater than 600 and less than 700, no adjustment for water quality is required.
- 11 The quality adjusted return flow from delivery of imported water delivered by both Western and the City of Riverside in areas tributary to the Riverside Narrows. For calendar years 1971 through 1991, no data are available. The only information available is the amounts of Return from Imported Water published in the Watermaster Annual Reports prior to April 1, 2014 (Table No. 16).

TABLE 11

CREDIT FOR RETURN FLOW RESULTING FROM DELIVERY OF IMPORTED WATER IN AREAS TRIBUTARY TO THE RIVERSIDE NARROWS
(All Quantities in Acre Feet Unless Otherwise Stated)

	2011	2012	2013	2014	2015	2016	2017	2018	2019	2020
Western Imported Domestic Water Deliveries	4	5,680	6,213							
Western Imported Water Agricultural Deliveries	2									
Subtotal of Western Imported Water Deliveries	3	5,680	6,213							
City of Riverside Imported Domestic Water Deliveries	4	5								
Imported Water Recharged in and Extracted from SBBA	5									
Total Deliveries of Imported Water	6	5,685	6,213							
Imported Water Return Flow Tributary to Narrows (at 36%)	7	2,047	2,237							
TDS of Delivered Water (mg/L)	8	170	290							
TDS of Return Flow from Delivered Water (mg/L)	9	307	524							
Amount of Adjustment Based on Quality of Imported Water	10	433	123							
Quality Adjusted Return Flow Resulting from Imported Water Delivered to Areas Tributary to the Narrows	11	2,480	2,360							

- 1 Imported water delivered by Western to domestic customers in areas tributary to the Riverside Narrows.
- 2 Imported water delivered by Western to agricultural customers in areas tributary to the Riverside Narrows.
- 3 The sum of imported water delivered by Western in areas tributary to the Riverside Narrows.
- 4 Imported water purchased by the City of Riverside through MWD connection WR-24C and delivered to areas tributary to the Riverside Narrows.
- 5 Extraction of additional water by Western or any Plaintiff from the San Bernardino Basin Area made pursuant to any Judgment Paragraph VI (b) 6 Agreement that provides for extraction of additional water in exchange for Western's purchase of a like amount of imported recharge water.
- 6 The sum of all imported water deliveries to areas tributary to the Riverside Narrows.
- 7 36 percent of imported water delivered to areas tributary to the Riverside Narrows.
- 8 TDS in mg/L of State Water Project water from the Henry J Mills Treatment Plant. Prior to 1980, imported water was delivered from the Colorado River Aqueduct at Lake Mathews.
- 9 TDS (mg/L) of return flow from delivered water in areas tributary to the Riverside Narrows. TDS of return flow is greater than TDS of delivered water as a result of consumptive use.
- 10 Judgment Paragraph XI (a) provides for adjustments for water quality of imported water returned to areas tributary to the Riverside Narrows using the following formula from the Orange County Judgment: Adjustment = $[(11 \times (Q/15250)) \times \Delta TDS]$. In the case where the TDS of return flow is less than 600 mg/L, the quality adjustment results in a positive value. In cases where the TDS of return flow is greater than 700 mg/L, the quality adjustment results in a negative value. In cases where the TDS of return flow is greater than 600 and less than 700, no adjustment for water quality is required.
- 11 The quality adjusted return flow from delivery of imported water delivered by both Western and the City of Riverside in areas tributary to the Riverside Narrows. For calendar years 1971 through 1991, no data are available. The only information available is the amounts of Return from Imported Water published in the Watermaster Annual Reports prior to April 1, 2014 (Table No. 16).

**WESTERN - SAN BERNARDINO WATERMASTER
FOR
WESTERN MUNICIPAL WATER DISTRICT et al.
vs.
EAST SAN BERNARDINO COUNTY WATER DISTRICT et al.
CASE NO. 78426 - COUNTY OF RIVERSIDE**

VOLUME 7 – 2012

**VERIFIED EXTRACTIONS FROM THE
SAN BERNARDINO BASIN AREA
FOR USE ON LANDS NOT WITHIN WESTERN
NOR TRIBUTARY TO THE RIVERSIDE NARROWS
AND FOR USE ON LANDS
WITHIN COLTON AND RIVERSIDE BASIN AREAS**

**ANNUAL ACCOUNTING
2012**

April 1, 2014

WATERMASTER
Douglas D. Headrick
John V. Rossi

REPORT OF WATERMASTER

Western Municipal Water District of Riverside County et al.
Plaintiffs

vs.

East San Bernardino County Water District et al.
Defendants

Superior Court of Riverside County

Case No. 78426

VOLUME 7-2012

VERIFIED EXTRACTIONS FROM THE
SAN BERNARDINO BASIN AREA
FOR USE ON LANDS NOT WITHIN WESTERN
NOR TRIBUTARY TO THE RIVERSIDE NARROWS
AND FOR USE ON LANDS
WITHIN COLTON AND RIVERSIDE BASIN AREAS

ANNUAL ACCOUNTING

2012

April 1, 2014

WATERMASTER

Douglas D. Headrick
John V. Rossi

VOLUME 7-2012

TABLE OF CONTENTS

Page

INTRODUCTION.....1

SECTION I

EXPORTS FROM THE SAN BERNARDINO BASIN AREA AND COLTON
BASIN AREA WITHIN THE SAN BERNARDINO VALLEY MUNICIPAL
WATER DISTRICT FOR USE ON LANDS NOT WITHIN
WESTERN NOR TRIBUTARY TO THE RIVERSIDE NARROWS

CHAPTER I

DELIVERIES TO CHINO BASIN.....6

TABLE A

VERIFIED EXTRACTIONS FROM THE SAN BERNARDINO BASIN AREA
AND COLTON BASIN AREA WITHIN THE SAN BERNARDINO VALLEY
MUNICIPAL WATER DISTRICT FOR USE ON LANDS NOT WITHIN
WESTERN NOR TRIBUTARY TO THE RIVERSIDE NARROWS
(1959-1963).....7

TABLE B

VERIFIED EXTRACTIONS FROM THE SAN BERNARDINO BASIN AREA
AND COLTON BASIN AREA WITHIN THE SAN BERNARDINO VALLEY
MUNICIPAL WATER DISTRICT FOR USE ON LANDS NOT WITHIN
WESTERN NOR TRIBUTARY TO THE RIVERSIDE NARROWS
(2008-2012).....8

FONTANA UNION WATER COMPANY.....9

TABLE NO. 1

VERIFICATION OF EXTRACTIONS FROM THE SAN BERNARDINO
BASIN AREA AND COLTON BASIN AREA WITHIN THE
SAN BERNARDINO VALLEY MUNICIPAL WATER DISTRICT FOR USE
ON LANDS NOT WITHIN WESTERN NOR TRIBUTARY TO THE
RIVERSIDE NARROWS -
FONTANA UNION WATER COMPANY.....11

WEST VALLEY WATER DISTRICT.....12

TABLE NO. 2

VERIFICATION OF EXTRACTIONS FROM THE SAN BERNARDINO
BASIN AREA AND COLTON BASIN AREA WITHIN THE
SAN BERNARDINO VALLEY MUNICIPAL WATER DISTRICT FOR USE
ON LANDS NOT WITHIN WESTERN NOR TRIBUTARY TO THE
RIVERSIDE NARROWS -
WEST VALLEY WATER DISTRICT.....13

CITY OF RIALTO.....14

TABLE NO. 3

VERIFICATION OF EXTRACTIONS FROM THE SAN BERNARDINO
BASIN AREA AND COLTON BASIN AREA WITHIN THE
SAN BERNARDINO VALLEY MUNICIPAL WATER DISTRICT FOR USE
ON LANDS NOT WITHIN WESTERN NOR TRIBUTARY TO THE
RIVERSIDE NARROWS -
CITY OF RIALTO.....16

CHAPTER II

DELIVERIES TO AREAS OTHER THAN CHINO BASIN.....17

TABLE NO. 4

VERIFICATION OF EXTRACTIONS FROM THE SAN BERNARDINO
BASIN AREA AND COLTON BASIN AREA WITHIN THE
SAN BERNARDINO VALLEY MUNICIPAL WATER DISTRICT FOR USE
ON LANDS NOT WITHIN WESTERN NOR TRIBUTARY TO THE
RIVERSIDE NARROWS -
SAN BERNARDINO VALLEY MUNICIPAL WATER DISTRICT.....19

MAP NO. 1

FONTANA UNION WATER COMPANY LANDS RECEIVING WATER
EXTRACTED FROM THE SAN BERNARDINO BASIN AREA AND COLTON
BASIN AREA WITHIN THE SAN BERNARDINO VALLEY MUNICIPAL
WATER DISTRICT FOR USE ON LANDS NOT WITHIN WESTERN NOR
TRIBUTARY TO THE RIVERSIDE NARROWS.....20

MAP NO. 2

WEST VALLEY WATER DISTRICT LANDS RECEIVING WATER
EXTRACTED FROM THE SAN BERNARDINO BASIN AREA AND COLTON
BASIN AREA WITHIN THE SAN BERNARDINO VALLEY MUNICIPAL
WATER DISTRICT FOR USE ON LANDS NOT WITHIN WESTERN NOR
TRIBUTARY TO THE RIVERSIDE NARROWS.....21

MAP NO. 3

CITY OF RIALTO AND LANDS THEREIN RECEIVING WATER
EXTRACTED FROM THE SAN BERNARDINO BASIN AREA AND COLTON
BASIN AREA WITHIN THE SAN BERNARDINO VALLEY MUNICIPAL
WATER DISTRICT FOR USE ON LANDS NOT WITHIN WESTERN NOR
TRIBUTARY TO THE RIVERSIDE NARROWS.....22

MAP NO. 4

SAN BERNARDINO VALLEY MUNICIPAL WATER DISTRICT'S MILL
CREEK PIPELINE AND LANDS WITHIN YUCAIPA BASIN WHICH
RECEIVE WATER DIVERTED FROM THE SAN BERNARDINO
BASIN AREA.....23

SECTION II

EXPORTS FROM THE SAN BERNARDINO BASIN AREA FOR USE ON
LANDS NOT WITHIN WESTERN NOR TRIBUTARY TO THE
RIVERSIDE NARROWS

CHAPTER III

DELIVERIES TO CHINO BASIN FROM THE SAN BERNARDINO
BASIN AREA.....24

TABLE C

DETERMINATION OF EXTRACTIONS FOR USE ON LANDS NOT
WITHIN WESTERN NOR TRIBUTARY TO THE RIVERSIDE NARROWS
FROM THE SAN BERNARDINO BASIN AREA (1959-1963).....26

TABLE D

DETERMINATION OF EXTRACTIONS FOR USE ON LANDS NOT
WITHIN WESTERN NOR TRIBUTARY TO THE RIVERSIDE NARROWS
FROM THE SAN BERNARDINO BASIN AREA (2008-2012).....27

FONTANA UNION WATER COMPANY.....28

TABLE NO. 5

DETERMINATION OF DELIVERIES FOR USE ON LANDS NOT WITHIN
WESTERN NOR TRIBUTARY TO THE RIVERSIDE NARROWS FROM
SAN BERNARDINO BASIN AREA -
FONTANA UNION WATER COMPANY.....29

WEST VALLEY WATER DISTRICT.....30

TABLE NO. 6

DETERMINATION OF DELIVERIES FOR USE ON LANDS NOT WITHIN
WESTERN NOR TRIBUTARY TO THE RIVERSIDE NARROWS FROM
SAN BERNARDINO BASIN AREA BASED ON TOTAL SUPPLY FROM
SAN BERNARDINO BASIN AREA, COLTON BASIN AREA WITHIN
SAN BERNARDINO VALLEY, RIVERSIDE BASIN AREA WITHIN
SAN BERNARDINO COUNTY, AND STATE WATER PROJECT WATER -
WEST VALLEY WATER DISTRICT.....31

CITY OF RIALTO.....32

TABLE NO. 7

DETERMINATION OF DELIVERIES FOR USE ON LANDS NOT WITHIN
WESTERN NOR TRIBUTARY TO THE RIVERSIDE NARROWS FROM
SAN BERNARDINO BASIN AREA BASED ON TOTAL SUPPLY FROM
SAN BERNARDINO BASIN AREA, COLTON BASIN AREA WITHIN
SAN BERNARDINO VALLEY AND RIVERSIDE BASIN AREA WITHIN
SAN BERNARDINO COUNTY -
CITY OF RIALTO.....33

SECTION III

DELIVERIES FROM THE SAN BERNARDINO BASIN AREA FOR USE ON
LANDS WITHIN THE COLTON BASIN AREA WITHIN SAN BERNARDINO
VALLEY AND RIVERSIDE BASIN AREA WITHIN
SAN BERNARDINO COUNTY

CHAPTER IV

DELIVERIES TO THE COLTON BASIN AREA WITHIN
SAN BERNARDINO VALLEY AND RIVERSIDE BASIN AREA WITHIN
SAN BERNARDINO COUNTY FROM THE SAN BERNARDINO BASIN
AREA.....34

TABLE E

DETERMINATION OF EXTRACTIONS FROM THE SAN BERNARDINO
BASIN AREA FOR USE ON LANDS WITHIN THE COLTON BASIN
AREA WITHIN SAN BERNARDINO VALLEY AND RIVERSIDE BASIN
AREA WITHIN SAN BERNARDINO COUNTY (1959-1963).....35

TABLE F

DETERMINATION OF EXTRACTIONS FROM THE SAN BERNARDINO
BASIN AREA FOR USE ON LANDS WITHIN THE COLTON BASIN
AREA WITHIN SAN BERNARDINO VALLEY AND RIVERSIDE BASIN
AREA WITHIN SAN BERNARDINO COUNTY,
INCREASED DELIVERIES THERETO, AND
INCREASED RETURN FLOW THERETO
(2008-2012).....36

FONTANA UNION WATER COMPANY.....37

TABLE NO. 8

DETERMINATION OF EXTRACTIONS FROM THE SAN BERNARDINO
BASIN AREA FOR USE ON LANDS WITHIN THE COLTON BASIN
AREA WITHIN SAN BERNARDINO VALLEY AND RIVERSIDE BASIN
AREA WITHIN SAN BERNARDINO COUNTY -
FONTANA UNION WATER COMPANY.....38

WEST VALLEY WATER DISTRICT.....39

TABLE NO. 9

DETERMINATION OF EXTRACTIONS FROM THE SAN BERNARDINO
BASIN AREA FOR USE ON LANDS WITHIN THE COLTON BASIN
AREA WITHIN SAN BERNARDINO VALLEY AND RIVERSIDE BASIN
AREA WITHIN SAN BERNARDINO COUNTY -
WEST VALLEY WATER DISTRICT.....40

CITY OF RIALTO.....41

TABLE NO. 10

DETERMINATION OF EXTRACTIONS FROM THE SAN BERNARDINO
BASIN AREA FOR USE ON LANDS WITHIN THE COLTON BASIN
AREA WITHIN SAN BERNARDINO VALLEY AND RIVERSIDE BASIN
AREA WITHIN SAN BERNARDINO COUNTY -
CITY OF RIALTO.....42

CITY OF COLTON.....43

TABLE NO. 11

DETERMINATION OF EXTRACTIONS FROM THE SAN BERNARDINO
BASIN AREA FOR USE ON LANDS WITHIN THE COLTON BASIN
AREA WITHIN SAN BERNARDINO VALLEY AND RIVERSIDE BASIN
AREA WITHIN SAN BERNARDINO COUNTY -
CITY OF COLTON.....44

CITY OF SAN BERNARDINO.....45

TABLE NO. 12

DETERMINATION OF EXTRACTIONS FROM THE SAN BERNARDINO
BASIN AREA FOR USE ON LANDS WITHIN THE COLTON BASIN
AREA WITHIN SAN BERNARDINO VALLEY AND RIVERSIDE BASIN
AREA WITHIN SAN BERNARDINO COUNTY -
CITY OF SAN BERNARDINO.....46

TERRACE WATER COMPANY.....47

TABLE NO. 13

DETERMINATION OF EXTRactions FROM THE SAN BERNARDINO
BASIN AREA FOR USE ON LANDS WITHIN THE COLTON BASIN
AREA WITHIN SAN BERNARDINO VALLEY AND RIVERSIDE BASIN
AREA WITHIN SAN BERNARDINO COUNTY -
TERRACE WATER COMPANY.....48

SECTION IV

LOSS OF RETURN FLOW RELATED TO INCREASED DELIVERIES FROM
COLTON BASIN AREA WITHIN SAN BERNARDINO VALLEY AND
RIVERSIDE BASIN AREA WITHIN SAN BERNARDINO COUNTY
FOR USE ON LANDS NOT WITHIN WESTERN NOR TRIBUTARY TO
THE RIVERSIDE NARROWS

AND

CREDIT FOR INCREASED RETURN FLOW RELATED TO
NEW DELIVERIES OF WATER
FROM OUTSIDE THE BASINS TO
COLTON BASIN AREA WITHIN SAN BERNARDINO VALLEY AND
RIVERSIDE BASIN AREA WITHIN SAN BERNARDINO COUNTY

CHAPTER V

INCREASED DELIVERIES FROM THE COLTON BASIN AREA WITHIN
SAN BERNARDINO VALLEY FOR USE ON LANDS NOT WITHIN
WESTERN NOR TRIBUTARY TO THE RIVERSIDE NARROWS, AND
LOSS OF RETURN FLOW RELATED TO SUCH INCREASED
DELIVERIES.....49

TABLE G

DETERMINATION OF DELIVERIES FROM THE COLTON BASIN AREA
WITHIN SAN BERNARDINO VALLEY FOR USE ON LANDS NOT
WITHIN WESTERN NOR TRIBUTARY TO THE RIVERSIDE NARROWS
(1959-1963).....50

TABLE H

DETERMINATION OF INCREASED DELIVERIES FROM THE COLTON
BASIN AREA WITHIN SAN BERNARDINO VALLEY FOR USE ON
LANDS NOT WITHIN WESTERN NOR TRIBUTARY TO THE RIVERSIDE
NARROWS, AND
LOSS OF RETURN FLOW RELATED TO SUCH INCREASED
DELIVERIES
(2008-2012).....51

FONTANA UNION WATER COMPANY.....52

TABLE NO. 14

DETERMINATION OF DELIVERIES FROM THE COLTON BASIN AREA
WITHIN SAN BERNARDINO VALLEY FOR USE ON LANDS NOT
WITHIN WESTERN NOR TRIBUTARY TO THE RIVERSIDE NARROWS -
FONTANA UNION WATER COMPANY.....53

WEST VALLEY WATER DISTRICT.....54

TABLE NO. 15

DETERMINATION OF DELIVERIES FROM THE COLTON BASIN AREA
WITHIN SAN BERNARDINO VALLEY FOR USE ON LANDS NOT
WITHIN WESTERN NOR TRIBUTARY TO THE RIVERSIDE NARROWS
BASED ON TOTAL SUPPLY -
WEST VALLEY WATER DISTRICT.....55

CITY OF RIALTO.....56

TABLE NO. 16

DETERMINATION OF DELIVERIES FROM THE COLTON BASIN AREA
WITHIN SAN BERNARDINO VALLEY FOR USE ON LANDS NOT
WITHIN WESTERN NOR TRIBUTARY TO THE RIVERSIDE NARROWS
BASED ON TOTAL SUPPLY -
CITY OF RIALTO.....57

CHAPTER VI

INCREASED DELIVERIES FROM THE RIVERSIDE BASIN AREA
WITHIN SAN BERNARDINO COUNTY FOR USE ON LANDS NOT
WITHIN WESTERN NOR TRIBUTARY TO THE RIVERSIDE NARROWS,
AND LOSS OF RETURN FLOW RELATED TO SUCH INCREASED
DELIVERIES.....58

TABLE I

DETERMINATION OF DELIVERIES FROM THE RIVERSIDE BASIN
AREA WITHIN SAN BERNARDINO COUNTY FOR USE ON LANDS NOT
WITHIN WESTERN NOR TRIBUTARY TO THE RIVERSIDE NARROWS
(1959-1963).....59

TABLE J

DETERMINATION OF INCREASED DELIVERIES FROM THE
RIVERSIDE BASIN AREA WITHIN SAN BERNARDINO COUNTY FOR
USE ON LANDS NOT WITHIN WESTERN NOR TRIBUTARY TO THE
RIVERSIDE NARROWS, AND
LOSS OF RETURN FLOW RELATED TO SUCH INCREASED
DELIVERIES
(2008-2012).....60

FONTANA UNION WATER COMPANY.....61

TABLE NO. 17

DETERMINATION OF DELIVERIES FROM THE RIVERSIDE BASIN
AREA WITHIN SAN BERNARDINO COUNTY FOR USE ON LANDS NOT
WITHIN WESTERN NOR TRIBUTARY TO THE RIVERSIDE NARROWS -
FONTANA UNION WATER COMPANY.....62

WEST VALLEY WATER DISTRICT.....63

TABLE NO. 18

DETERMINATION OF DELIVERIES FROM THE RIVERSIDE BASIN
AREA WITHIN SAN BERNARDINO COUNTY FOR USE ON LANDS NOT
WITHIN WESTERN NOR TRIBUTARY TO THE RIVERSIDE NARROWS
BASED ON TOTAL SUPPLY -
WEST VALLEY WATER DISTRICT.....64

CITY OF RIALTO.....65

TABLE NO. 19

DETERMINATION OF DELIVERIES FROM THE RIVERSIDE BASIN
AREA WITHIN SAN BERNARDINO COUNTY FOR USE ON LANDS NOT
WITHIN WESTERN NOR TRIBUTARY TO THE RIVERSIDE NARROWS
BASED ON TOTAL SUPPLY -
CITY OF RIALTO.....66

CHAPTER VII

LOSS OF RETURN FLOW RELATED TO INCREASED DELIVERIES
FROM COLTON BASIN AREA WITHIN SAN BERNARDINO VALLEY AND
RIVERSIDE BASIN AREA WITHIN SAN BERNARDINO COUNTY FOR
USE ON LANDS NOT WITHIN WESTERN NOR TRIBUTARY TO THE
RIVERSIDE NARROWS.....67

TABLE K.....67

TABLE K

ANNUAL ACCOUNTING FOR SAN BERNARDINO VALLEY MUNICIPAL
WATER DISTRICT - LOSS OF RETURN FLOW RELATED TO
INCREASED DELIVERIES FROM COLTON BASIN AREA WITHIN
SAN BERNARDINO VALLEY AND RIVERSIDE BASIN AREA WITHIN
SAN BERNARDINO COUNTY FOR USE ON LANDS NOT WITHIN
WESTERN NOR TRIBUTARY TO THE RIVERSIDE NARROWS.....68

CHAPTER VIII

CREDIT FOR INCREASED RETURN FLOW RELATED TO NEW
DELIVERIES OF WATER FROM OUTSIDE THE BASINS TO COLTON
BASIN AREA WITHIN SAN BERNARDINO VALLEY AND RIVERSIDE
BASIN AREA WITHIN SAN BERNARDINO COUNTY69

TABLE L.....69

TABLE L

ANNUAL ACCOUNTING FOR SAN BERNARDINO VALLEY MUNICIPAL WATER DISTRICT - CREDIT FOR INCREASED RETURN FLOW RELATED TO NEW DELIVERIES OF WATER FROM OUTSIDE THE BASINS TO COLTON BASIN AREA WITHIN SAN BERNARDINO VALLEY AND RIVERSIDE BASIN AREA WITHIN SAN BERNARDINO COUNTY.....70

WEST VALLEY WATER DISTRICT.....71

TABLE NO. 20

DETERMINATION OF NEW DELIVERIES OF STATE WATER PROJECT WATER TO COLTON BASIN AREA WITHIN SAN BERNARDINO VALLEY AND RIVERSIDE BASIN AREA WITHIN SAN BERNARDINO COUNTY BASED ON TOTAL SUPPLY, AND INCREASED RETURN FLOW RELATED TO SUCH NEW DELIVERIES - WEST VALLEY WATER DISTRICT.....72

SECTION V

USES OF WATER IMPORTED FROM THE STATE WATER PROJECT

CHAPTER IX

STATE WATER PROJECT WATER73

TABLE NO. 21

STATE WATER PROJECT DELIVERIES FOR SAN BERNARDINO VALLEY MUNICIPAL WATER DISTRICT BY TYPE AND PLACE OF USE74

TABLE NO. 22

STATE WATER PROJECT DELIVERIES FOR SAN BERNARDINO VALLEY MUNICIPAL WATER DISTRICT - SAN BERNARDINO BASIN AREA RETURN FLOW.....75

VOLUME 7-2012

INTRODUCTION

The settlement of the case of the Orange County Water District, Plaintiff, vs. City of Chino, et al., Defendants, being Case No. 117628 in the Superior Court of the State of California in and for the County of Orange, necessitated a settlement of the case of Western Municipal Water District, et al., Plaintiffs, vs. East San Bernardino County Water District, et al., Defendants, which was settled by Stipulated Judgment in Case No. 78426, entered in the Superior Court of the State of California in and for the County of Riverside, on April 17, 1969. Such Judgment was amended on February 28, 1992.

Paragraph X of the original Judgment, titled, "Replenishment to Offset New Exports of Water Not Tributary to the Riverside Narrows" recites as follows:

"Certain average annual amounts of water extracted from the San Bernardino Basin Area and the area downstream therefrom to Riverside Narrows during the five year period ending in 1963 have been exported for use outside the area tributary to Riverside Narrows ..."

"San Bernardino Valley shall be obligated to provide replenishment for any increase over the exports from San Bernardino Valley for use in any area not within Western nor tributary to Riverside Narrows as set forth in Table C-2 of Appendix "C", such amounts being subject to correction by the Watermaster ..."

Pursuant to the foregoing instructions, the Watermaster conducted an investigation of water produced within the San Bernardino Basin Area and Colton Basin Area within San Bernardino Valley and delivered to lands not within Western nor tributary to the Riverside Narrows. The results of this investigation which included the five-year base period 1959-1963 as well as the verified production for the Calendar Years 1970 and 1971 were embodied in Report of Watermaster, Volume 7 - Base Period 1959-1963 and 1970-1971, dated February, 1973.

During the verification of the extractions from the San Bernardino Basin Area and Colton Basin Area within San Bernardino Valley for the Calendar Year 1973, the amounts previously verified for the base period (calendar years) 1959-

1963 were revised. The revised verified amounts for the base period 1959-1963 are shown on Table A of this report in Section I, Chapter I. The verified amounts for calendar years 2008-2012 are shown on Table B of this volume in Section I, Chapter I. Procedures and basic data used in preparation of Tables A and B are contained in Section I, Chapters I and II, of this report.

In Section I, pursuant to the original Judgment, the combined New Export from both San Bernardino Basin Area and Colton Basin Area within San Bernardino Valley is determined. Under this approach, all New Export resulted in an obligation to replenish in the San Bernardino Basin Area even though some of the exported extractions were from the Colton Basin Area within San Bernardino Valley. Another approach was developed in 2013 to address this matter and partially implement the 1992 Amendment.

The 1992 Amendment included several changes that affect the methods that Watermaster uses to account for New Export. First, the second reference to San Bernardino Valley in the second quotation above was changed to San Bernardino Basin Area and new provisions for the Colton Basin Area within San Bernardino Valley and Riverside Basin Area within San Bernardino County were added later in the paragraph. Replenishment obligations for San Bernardino Valley pursuant to the 1992 amended Paragraph X are as follows:

"... San Bernardino Valley shall be obligated to provide replenishment for any increase over the exports from the San Bernardino Basin Area for use in any area not within Western nor tributary to Riverside Narrows as set forth in Table C-2 of Appendix "C", such amounts being subject to correction by the Watermaster, or for any exports from the San Bernardino Basin Area for use in the Yucaipa, San Timoteo, Oak Glen and Beaumont Basins. San Bernardino Valley shall also be obligated to provide replenishment in the Colton or Riverside Basin, as the case may be, to offset loss of return flow related to any increase over the exports therefrom within San Bernardino Valley for use in any area not within Western nor tributary to Riverside Narrows as set forth in Table C-2 of Appendix "C", such amounts being subject to correction by the Watermaster. Against its replenishment obligation to offset loss of return flow related to any increase in the exports from the Colton Basin Area or Riverside Basin Area within San Bernardino Valley,

San Bernardino Valley shall receive credit for that portion of direct delivered water which originated outside that Basin and which returns to the ground water of that Basin." (underline indicates changes and additions to the original Judgment.)

Pursuant to the 1992 Amendment, Section II provides data which allows determination of only the New Export from the San Bernardino Basin Area to the Chino Basin in Table No. 15A of the Annual Report. Such determination is accomplished by using the data developed in Section I along with data in other data volumes.

The verified amounts exported from only the San Bernardino Basin Area to the Chino Basin for the base period 1959-1963 are shown in Table C of this report. The verified amounts for calendar years 2008-2012 are shown in table D of this report.

Procedures and basic data used in preparation of Tables C and D are contained in Section II, Chapter III, of this report.

The 1992 Amendment included new provisions related to accounting for the export to Chino Basin of extractions from the Colton and Riverside Basins. Such provisions require a determination of the credit in those Basins resulting from the delivery of extractions from the San Bernardino Basin Area. The specific language in Paragraph X of the amended Judgment requiring these determinations is:

"... San Bernardino Valley shall receive credit for that portion of direct delivered water which originated outside that Basin (Colton Basin Area within San Bernardino Valley or Riverside Basin Area within San Bernardino County) and which returns to the ground water of that Basin (Colton Basin Area within San Bernardino Valley or Riverside Basin Area within San Bernardino County)." (emphasis and parenthetical note added)

This Amendment provides that San Bernardino Valley will receive credit against any obligations in the Colton Basin Area within San Bernardino Valley and Riverside Basin Area within San Bernardino County for the return flow resulting from the delivery to such Basin Areas of extractions that originate outside the Basins. Such deliveries from the San Bernardino Basin Area to the Colton Basin Area within San Bernardino Valley and Riverside Basin Area within San Bernardino County are

accounted for in Section III. Such accounting was performed to eventually be able to credit San Bernardino Valley obligations in the Colton Basin Area within San Bernardino Valley and Riverside Basin Area within San Bernardino County as required by the Amendment and to maintain hydrologic integrity in the San Bernardino Basin Area as referenced in Watermaster documents that supported the 1992 Amendment. Hydrologic integrity of the San Bernardino Basin Area is maintained by excluding from determinations of credits and obligations the return flow resulting from Basin extractions that are used anywhere outside the Basin. Any increase in deliveries of San Bernardino Basin Area extractions, relative to the base period, to the Colton Basin Area within San Bernardino Valley and Riverside Basin Area within San Bernardino County is now referred to as New Deliveries.

Section III provides data which allows determination of New Deliveries from the San Bernardino Basin Area for use on lands within the Colton Basin Area within San Bernardino Valley and Riverside Basin Area within San Bernardino County utilizing the data developed in Section II along with data in other data volumes.

The verified extractions from the San Bernardino Basin Area delivered for use on lands within the Colton Basin Area within San Bernardino Valley and Riverside Basin Area within San Bernardino County for the base period 1959-1963 are shown in Table E of this report. The verified amounts for calendar years 2008-2012 are shown in Table F of this report.

Procedures and basic data used in preparation of Tables E and F are contained in Section III, Chapter IV, of this report.

Section IV provides data which allows determination of Loss of Return Flow from the Colton Basin Area within San Bernardino Valley and Riverside Basin Area within San Bernardino County utilizing data developed in prior sections and other Volumes of the Annual Report.

Determination of Increased Return Flow to the Colton Basin Area within San Bernardino Valley and Riverside Basin Area within San Bernardino County utilizing data developed in prior sections and other Volumes of the Annual Report is also made.

Section V verifies deliveries of State Water Project water to San Bernardino Valley Municipal Water District by type and place of use.

The verified amounts of State Water Project water delivered within the San Bernardino Basin Area and its uses are shown in Chapter V of this report in Table Nos. 21 and 22.

VOLUME 7-2012

SECTION I

COMBINED EXPORTS FROM THE SAN BERNARDINO BASIN AREA AND COLTON
BASIN AREA WITHIN THE SAN BERNARDINO VALLEY MUNICIPAL WATER
DISTRICT FOR USE ON LANDS NOT WITHIN WESTERN NOR TRIBUTARY TO
THE RIVERSIDE NARROWS

CHAPTER I

DELIVERIES TO CHINO BASIN

The verified amounts set forth in this Chapter pertain solely to those extractions from the San Bernardino Basin Area and Colton Basin Area within the San Bernardino Valley Municipal Water District for use on lands situated within the Chino Basin.

The entities delivering water to this area include Fontana Union Water Company, West Valley Water District and the City of Rialto. Maps Nos. 1, 2 and 3 included herein delineate the boundaries of the three agencies respectively, and also show the lands within each agency which are not within Western nor tributary to the Riverside Narrows. For purposes of this determination such lands are considered as lying northerly of the groundwater divide separating the Riverside and Chino Basins and westerly of the Rialto-Colton Fault. The verified amounts for the base period 1959-1963 are shown in Table A of this report. The verified amounts for calendar years 2008-2012 are shown in Table B.

Deliveries to these areas within each agency have been determined as follows:

TABLE A

VERIFIED EXTRACTIONS FROM THE
SAN BERNARDINO BASIN AREA AND COLTON BASIN AREA
WITHIN THE SAN BERNARDINO VALLEY MUNICIPAL WATER
DISTRICT FOR USE ON LANDS NOT WITHIN
WESTERN NOR TRIBUTARY TO THE RIVERSIDE NARROWS

<u>Deliveries To</u>	<u>Source In This Volume</u>	<u>1959-63 Ave. Annual Amount</u>	
<u>Areas Within Chino Basin</u>			
	<u>Chapter I</u>		
Fontana Union Water Company	Table No. 1, Column No. 12	10,170	*
West Valley Water District	Table No. 2, Column No. 7	1,806	
City of Rialto	Table No. 3, Column No. 14	551	**
<u>Areas Other Than Chino Basin</u>			
	<u>Chapter II</u>		
Yucaipa		0	
San Timoteo		0	
Oak Glen		0	
Beaumont		<u>0</u>	
Total		12,527	

* Original Verification of 10,903 acre-feet revised to 10,170 acre-feet during 1973 verification.

** Original Verification of 781 acre-feet revised to 551 acre-feet during 1973 verification.

TABLE NO. B

VERIFIED EXTRACTIONS FROM THE
SAN BERNARDINO BASIN AREA AND COLTON BASIN AREA
WITHIN THE SAN BERNARDINO VALLEY MUNICIPAL WATER
DISTRICT FOR USE ON LANDS NOT WITHIN
WESTERN NOR TRIBUTARY TO THE RIVERSIDE NARROWS

Deliveries to	Table #	Column #	2008	2009	2010	2011	2012	5 yr. Total	2008-12 Average
Areas Within Chino Basin									
Fontana Union Water Company	1	12	20,389	15,177	19,421	30,786	18,672	104,445	20,889
West Valley Water District	2	7	8,189	7,374	6,820	4,850	5,590	32,823	6,565
City of Rialto	3	14	1,657	1,711	1,877	1,168	1,216	7,629	1,526
Subtotal (Delivery to Chino Basin)			30,235	24,262	28,118	36,804	25,478	144,897	28,980
Areas Other Than Chino Basin									
Yucaipa	4	2	0	0	0	0	0	0	0
San Timoteo	-	-	0	0	0	0	0	0	0
Oak Glen	-	-	0	0	0	0	0	0	0
Beaumont	-	-	0	0	0	0	0	0	0
Others	-	-	102 ¹⁾	0	0	0	0	102	20
Subtotal (Delivery to Other than Chino Basin)			102	0	0	0	0	102	20
Total Water Delivery			30,337	24,262	28,118	36,804	25,478	144,999	29,000

¹⁾ 102 Acre Feet of water was pumped into the Metropolitan Water District of Southern California Inland Feeder Project from the San Bernardino Valley Water District's Central Feeder System.

FONTANA UNION WATER COMPANY

The lands served by the Fontana Union Water Company which include the San Gabriel Valley Water Company and which are not within Western nor tributary to the Riverside Narrows are shown on Map No. 1. The location of wells and surface diversion facilities which produce water delivered to said lands are also shown.

The total production from the San Bernardino Basin Area and Colton Basin Area within San Bernardino Valley Municipal Water District available for use on the nontributary lands have been determined by the sum of the following:

1. Production from Fontana Union Water Company wells situated within the San Bernardino Basin Area and Colton Basin Area within the San Bernardino Valley Municipal Water District as reported in Recordation Filings to the State Water Resources Control Board and verified by the Watermaster with the exception that two wells situated on the Lytle Creek stream channel at Miller Narrows deliver water into the Lytle Creek powerhouse penstock. This water has been commingled with surface production.
2. Deliveries to Fontana Union Water Company's "Breedline" measured at the Fontana Powerhouse forebay Weir No. 4 and adjusted for deliveries to the Breedline from Fontana Union Water Company Well No. 27.
3. Deliveries to the Fontana Union Water Company measured at their 20 foot weir diverting from the Fontana Powerhouse afterbay plus diversions from the afterbay for delivery to City of Rialto and Owl Service Rock Company.

The Item 3 deliveries to Fontana Union Water Company reckoned at the Fontana Powerhouse 20' Weir were measured by Fontana Union Water Company and the United States Geological Survey. Since United States Geological Survey measurements were based on data obtained by continuous stage recorder as opposed to instantaneous measurements by Fontana Union Water Company two to three times daily, the United States Geological Survey data were used for purposes of the determinations contained in this

report. In addition to surface diversions from Lytle Creek, the United States Geological Survey data also include an undetermined amount of water produced by the Miller Narrows Wells and may from time to time also include water obtained by temporary arrangements with other agencies diverting from the Fontana Powerhouse afterbay. For these reasons the amounts used by the Watermaster are for purposes of this report only (i.e. deliveries to Chino Basin) and are not to be construed as a Watermaster verification of the total production by Fontana Union Water Company from either San Bernardino Basin Area or Colton Basin Area within San Bernardino Valley.

In order to determine the net deliveries to the nontributary area (Chino Basin) the total was adjusted for deliveries to tributary areas as follows:

1. Deliveries to the City of San Bernardino from Fontana Union Water Company Well No. 1, reported by Fontana Union Water Company as total production of this well.
2. Water delivered to the Owl Service Rock Company and its successor Cemex located within the San Bernardino Basin Area as reported by Fontana Union Water Company.
3. Water delivered for use on citrus groves situated within the Colton Basin Area within San Bernardino Valley as reported by Fontana Union Water Company.
4. Water delivered to City of Rialto through West Valley Water District diversion facilities at Fontana Powerhouse afterbay.

The components of production and delivery by the Fontana Union Water Company for the base period 1959-1963 and calendar years 2008-2012, together with the indicated deliveries to Chino Basin, are summarized in Table No. 1.

TABLE NO. 1

VERIFICATION OF EXTRACTIONS FROM THE
SAN BERNARDINO BASIN AREA AND COLTON BASIN AREA
WITHIN THE SAN BERNARDINO VALLEY MUNICIPAL WATER
DISTRICT FOR USE ON LANDS NOT WITHIN
WESTERN NOR TRIBUTARY TO THE RIVERSIDE NARROWS

FONTANA UNION WATER COMPANY
 (Quantities in Acre Feet)

Year	PRODUCTION				DELIVERIES TO AREAS TRIBUTARY TO RIVERSIDE NARROWS						Total	Export to Chino Basin in San Bernardino Co. Nontributary
	San Bernardino Basin Area	Breed Line	Surface Water	Colton Basin Area Wells	Total Prod.	CEMEX	City of San B'dno.	Citrus	City of Rialto	(11)		
(1)	(2)	(3)	(4)	(5)	(6)	(7)	(8)	(9)	(10)	(11)	(12)	
1959	9,169	7,964	501	31	17,665	323	1,393	700	0	2,416	15,249	
1960	6,671	5,344	521	31	12,567	491	1,396	600	0	2,487	10,080	
1961	5,968	3,864	413	31	10,276	417	1,765	600	0	2,782	7,494	
1962	3,521	8,225	526	31	12,303	481	746	500	0	1,727	10,576	
1963	2,779	5,692	522	31	9,024	446	726	400	0	1,572	7,452	
5-Yr. Avg.					12,367					2,197	10,170	
2008	10,523	10,146	0	0	20,669	280	0	0	0	280	20,389	
2009	7,789	7,720	0	0	15,509	332	0	0	0	332	15,177	
2010	7,074	12,858	0	0	19,932	511	0	0	0	511	19,421	
2011	9,574	21,620	0	0	31,194	408	0	0	0	408	30,786	
2012	12,605	6,582	0	0	19,187	515	0	0	0	515	18,672	
5-Yr. Avg.	9,513	11,785	0	0	21,298	409	0	0	0	409	20,889	

Column Explanation:

- (2) Table No. 1 of Volume No. 1 of the Watermaster Report (excluding Miller Narrows Wells Recordation No.'s 3600588 and 3600590 and Lytle Creek Diversion Recordation No. 3600591).
- (3) United States Geological Survey and Fontana Union Water Company records of diversions from Fontana Powerhouse 11062820 Afterbay including deliveries to CEMEX.
- (4) Line No.17 for 1959-63 and Line No.19 for 1971 to date on Table No.4 of Volume No.1 of the Watermaster Report (excludes production of Fontana Union Well No. 27, Recordation No. 3600582).
- (5) Table No.1 of Volume No.2 of the Watermaster Report (excluding Wells Recordation No.'s 3600577, 3600578, 3600589, 3603060, 3603626, 3603726, 3603739, 3603764, & 3603765 which are not within S.B.V.M.W.D.).
- (6) Sum of Columns (2) + (3) + (4) + (5).
- (7) Fontana Union Water Company Records. Estimated in recent years. Now Cemex, water use provided by company.
- (8) Fontana Union Water Company Records Total Production of Fontana Union Well No. 1, Recordation No. 3600561.
- (9) Fontana Union Water Company Records.
- (10) Fontana Union Water Company Records.
- (11) Sum of Columns (7) + (8) + (9) + (10).
- (12) Difference of Column (6) minus Column (11).

Note: Table No. 1 revised during the 1973 verification.

WEST VALLEY WATER DISTRICT

The lands served by the West Valley Water District which are not within Western nor tributary to the Riverside Narrows are delineated on Map No. 2. Water delivered to said area was obtained from wells located within the San Bernardino Basin Area and Colton Basin Area within San Bernardino Valley and surface diversions from Lytle Creek. In addition these lands also received water extracted from three wells within the Chino Basin.

The total deliveries to the nontributary area (Chino Basin) were based on the actual metered deliveries obtained from the records of the West Valley Water District. Since a portion of this water was supplied by wells located within the nontributary area, the total deliveries were reduced by the amount supplied by said wells. West Valley Water District reports that the production from these wells is used wholly within the Chino Basin. Subsequent to the base period 1959-1963, the District records also include the Domestic and Commercial deliveries as determined from the meter books covering the nontributary area. These metered areas are also shown on Map No. 2.

The annual deliveries to nontributary areas by the West Valley Water District for the base period 1959-1963 and calendar years 2008-2012 are summarized in Table No. 2.

TABLE NO. 2

VERIFICATION OF EXTRACTIONS FROM THE
SAN BERNARDINO BASIN AREA AND COLTON BASIN AREA
WITHIN THE SAN BERNARDINO VALLEY MUNICIPAL WATER
DISTRICT FOR USE ON LANDS NOT WITHIN
WESTERN NOR TRIBUTARY TO THE RIVERSIDE NARROWS

WEST VALLEY WATER DISTRICT *
(Quantities in Acre Feet)

Year	Deliveries in Chino Basin	Production From Chino Basin Wells					Total	Export To Chino Basin In San Bernardino Co. Nontributary
		3600379	3600380	3601005	Well #37 3603757	Well #42 3603772		
(1)	(2)	(3)	(4)	(5)	(5a)	(5b)	(6)	
1959	3,103	133	498	233			864	
1960	2,424	140	520	38			698	
1961	3,046	158	559	297			1,014	
1962	2,576	137	536	262			935	
1963	2,225	100	509	227			836	
5-Yr.Avg.	2,675	134	524	211			869	
2008	8,189	-	-	-	0	0	0	
2009	8,127	-	-	-	0	753	753	
2010	9,164	-	-	-	0	2,344	2,344	
2011	6,921	-	-	-	0	2,071	2,071	
2012	7,436	-	-	-	0	1,846	1,846	
5-Yr.Avg.	7,967	-	-	-	0	1,403	1,403	

Column explanation:

- (2) Company records. Amount includes production of Wells Rec. Nos. 3600379, 3600380 & 3601005. Starting in 2003, using Chino Basin Watermaster Annual Report, Appendix J
- (3) So. Calif. Water Co. Well Rec. No. 3600379 purchased by W.S.B.C.W.D. in 1970. Has been destroyed
- (4) So. Calif. Water Co. Well Rec. No. 3600380 purchased by W.S.B.C.W.D. in 1970. Has been destroyed
- (5) Former Citizens Land & Water Co. merged in 1962 to form W.S.B.C.W.D. Presently a monitoring well
- (6) Column (3) + (4) + (5).
- (7) Column (2) minus (6). Deliveries in Chino Basin from production in San Bernardino Basin and Colton Basin Area.
- (8) 1998 data corrected during 1999 verification.

* West San Bernardino County Water District (WSBCWD) now West Valley Water District

CITY OF RIALTO

The lands served by the City of Rialto which are not within Western nor tributary to the Riverside Narrows are delineated on Map No. 3. Water delivered to the City was produced from wells within the San Bernardino Basin Area and Colton Basin Area within San Bernardino Valley and surface diversions from Lytle Creek. In addition the City also receives water extracted from a well within the Chino Basin.

The production records and records of water purchased together with records of metered customer deliveries are furnished by the City of Rialto.

The total water production delivered into the City's system has been determined as follows:

1. Production from City of Rialto wells situated within the San Bernardino Basin Area and Colton Basin Area within San Bernardino Valley as reported in Recordation Filings to the State Water Resources Control Board and verified from records furnished by the City.
2. Surface water diverted at Fontana Powerhouse afterbay and delivered to City of Rialto determined from City Records.
3. Water purchased by City of Rialto as determined from City Records.
4. Water produced in Chino Basin and delivered into City's system from Recordation Filing to the State Water Resources Control Board and City of Rialto records. Such water is produced from Well Recordation No. 3602270 and during the base period 1959-1963 was used solely for agricultural purposes in the Chino Basin. From 1966 to date this well delivered water into the City's domestic system and is considered to be used wholly within the Chino Basin.

Based on metered deliveries it was determined that the percentage of total production delivered to Chino Basin was about 18 percent as compared to the 28 percent used during the initial verification. The total production delivered to Chino Basin during the base period 1959-1963 was revised accordingly,

and beginning in 1971 the actual metered deliveries were used. The amount delivered to the Chino Basin was reduced by the total verified production within Chino Basin as set forth in Item (4) above, assuming that such production was used entirely within the Chino Basin as reported by the City. The remaining amount was considered representative of the total production from the San Bernardino Basin Area and Colton Basin Area within San Bernardino Valley exported to the Chino Basin by the City of Rialto.

Since the sewage effluent from the City Sewage Treatment Plant accrues to the Santa Ana River above the Riverside Narrows, the total exports were adjusted to reflect this return flow. Such adjustment was based on a percentage estimated at 32 percent for the year 1959 and increasing on a straight line basis to 40 percent in 1963. This assumption was predicated on the date of construction of the treatment plant and the gradual conversion of individual septic tanks and cesspools to the sewage system.

Analysis of the production and sewage plant effluent discharge data indicates an average effluent discharge from water exported to Chino Basin of about 39 percent for the calendar year 2001. This amount is weighted to account for the domestic, agricultural and industrial deliveries through the City's domestic system and the difference in sewage return flow accruing from such uses.

In May of 2009, these calculations were revisited. A detailed review of water sales records was made and production was calculated by water use types in each of the overlying meter book areas, with adjustments made to follow the defined Chino Basin boundaries. A review of March 2005 water use (above normal rainfall period) was used to determine indoor/sewered flow vs. outdoor use. These numbers appear on Table 3, columns (9) and (12).

The annual deliveries to nontributary areas for the base period 1959-1963 and calendar years 2008-2012 are summarized in Table No. 3.

TABLE NO. 3

VERIFICATION OF EXTRACTIIONS FROM THE
SAN BERNARDINO BASIN AREA AND COLTON BASIN AREA
WITHIN THE SAN BERNARDINO VALLEY MUNICIPAL WATER
DISTRICT FOR USE ON LANDS NOT WITHIN
WESTERN NOR TRIBUTARY TO THE RIVERSIDE NARROWS

Year	San Bernardino Basin		Colton Basin		Total Subject to Export	Chino Basin Well	Total Prod.	Water Required In Chino Basin	Chino Basin Wells	San B'dno. & Colton Basins Export To Chino Basin	Percent Return Flow to Sewer Plant	Return Flow to Sewer Plant	Total Export From San B'dno. & Colton Basins Nontributary					
	City of Rialto Wells	Surface Water	Total	City of Rialto Wells										Wells	(1)	(2)	(3)	(4)
1959	1,035	415	1,450	987	4,695	0	4,695	845	0	845	32%	270	575					
1960	169	625	794	808	4,654	0	4,654	838	0	838	34%	285	553					
1961	334	572	906	1,372	4,816	0	4,816	867	0	867	36%	312	555					
1962	481	587	1,068	1,477	4,943	0	4,943	890	0	890	38%	338	552					
1963	773	384	1,157	1,594	4,802	0	4,802	864	0	864	40%	346	518					
5-Yr. Avg.	558	517	1,075	1,248	4,782	0	4,782	861	0	861	-	310	551					
2008	5,380	1,165	6,545	2,352	12,300	685	12,985	4,000	685	3,315	50%	1,658	1,657					
2009	4,590	1,123	5,713	3,219	12,543	577	13,120	4,000	577	3,423	50%	1,712	1,711					
2010	4,115	1,210	5,325	2,782	10,687	245	10,932	4,000	245	3,755	50%	1,878	1,877					
2011	2,206	1,171	3,377	2,206	9,613	803	10,416	3,139	803	2,336	50%	1,168	1,168					
2012	1,798	1,311	3,109	2,771	10,610	976	11,586	3,409	976	2,433	50%	1,217	1,216					
5-Yr. Avg.	3,618	1,196	4,814	2,666	11,151	657	11,808	3,710	657	3,052	50%	1,527	1,526					

Column explanation:

- (2) Verified extractions, Volume 1, Report of Watermaster. Excludes Lytle Creek Diversion Recordation No. 3601718. Includes Well Recordation No. 3601085 after acquisition by City of Rialto.
- (3) Metered inflow to City of Rialto Filter Plant City of Rialto Records. Includes water delivered under stock entitlement City of Rialto owns in West San Bernardino County Water District and purchases from Fontana Union Water Co. (Rialto Filter Plant 3601718)
- (4) Verified extractions, Volume 2, Report of Watermaster. Includes production of Wells Recordation Nos. 3602269 & 3602271 after acquisition by City of Rialto.
- (5) City of Rialto Records of Purchases. Purchases from SBVMWD Baseline Feeder commencing 1990.
- (6) Sum Columns (2) + (3) + (4) + (5).
- (7) Well Recordation No. 3602270 acquired by City of Rialto in 1966 and a well constructed by City of Rialto (3603175 & 3603537)
- (8) Sum Columns (6) + (7).
- (9) Metered deliveries in Chino Basin from City of Rialto Billing Records beginning 1971. Base period years revised during 1973 verification to reflect 18% average distribution of metered deliveries by City of Rialto records for years 1971 through 1974.
- (10) Same as Column (7).
- (11) Difference Column (9) minus Column (10).
- (12) Assumed for Base Period. 1971 to date estimated weighted average return flow percentage based on: 1) metered agricultural and park deliveries with no return flow, 2) metered residential deliveries at 40 percent return flow, and 3) metered industrial deliveries (Phototron Company) at 90 percent return flow. In May 2009 a detailed study was completed which is described in text on previous page.
- (13) Product Column (11) times Column (12).
- (14) Difference Column (11) minus Column (13) net export of water produced in San Bernardino & Colton Basin Areas to Chino Basin.

Note: Table No. 3 revised during the 1973 verification.
In May 2009 a detail calculation of water delivery and return was completed using data from Rialto's water meter books by Steve Mains
Columns 9 and 12 data was adjusted for 2004, 2005, and 2006

VOLUME 7-2012

CHAPTER II

DELIVERIES TO AREAS OTHER THAN CHINO BASIN

Paragraph X of the Judgment also provides for replenishment by San Bernardino Valley to the extent exports are made from the San Bernardino Basin Area for use in the Yucaipa, San Timoteo, Oak Glen and Beaumont Basins.

The results of the initial verification of production from the San Bernardino Basin Area indicated that such exports were not made during the base period 1959-1963 nor prior to calendar year 1979.

During 1978 San Bernardino Valley constructed the Mill Creek Pipeline to convey water from the Southern California Edison Company Mill Creek #2/#3 Powerhouse afterbay to the Yucaipa Regional Park. As shown on Table 4, the pipeline was used extensively.

During 1987 San Bernardino Valley Municipal Water District completed construction of the "Yucaipa Pipeline" which conveys Mill Creek waters from the San Bernardino Basin Area to the Yucaipa Basin. Yucaipa Regional Park receives Mill Creek water which is used for maintenance of the reservoir levels, irrigation of the Park and limited spreading for recharge of the Yucaipa Groundwater Basin. Mill Creek water is also delivered into Wilson Creek Spreading Basins for recharge into Yucaipa Groundwater Basin. The location of the Yucaipa Pipeline, Yucaipa Regional Park, and Wilson Creek Spreading Basins are shown on Map No. 4 which is included herein.

During 2003 the State of California Department of Water Resources completed the East Branch Extension Phase I project. This project included facilities to provide delivery of State Water Project water to Yucaipa Valley within San Bernardino Valley Municipal Water District and to the San Gorgonio Pass Water Agency. Since completion of the East Branch Extension Phase I project State Water Project water has been delivered to the Yucaipa, San Timoteo, Oak Glen and Beaumont Basins.

During calendar year 2008, San Bernardino Valley Municipal Water District completed construction of portions of its Central Feeder Groundwater Banking/Conjunctive Use Project. The initial

portions of the Central Feeder included the Redlands Pump Station, several miles of the Central Feeder Pipeline and a connection to The Metropolitan Water District of Southern California Inland Feeder Project. The Central Feeder Project has many uses including high groundwater mitigation, distribution of water throughout the San Bernardino Basin Area and the San Bernardino Valley Municipal Water District in addition to its groundwater banking and conjunctive use concepts. During calendar year 2008, testing of the project included pumping 102 acre feet of water that had been extracted from wells in the San Bernardino Basin area into The Metropolitan Water District of Southern California Inland Feeder Project. The water that was pumped to test the Central Feeder project facilities was delivered into Inland Feeder Project and for the most part was conveyed through the Inland Feeder Project to Diamond Valley Reservoir. In this instance, the 102 acre feet of test water pumped in 2008, the ultimate fate of the water pumped was not prescribed. The Metropolitan Water District of Southern California distributed the water at its discretion. Under the terms of this Judgment and the previously described circumstances, the 102 acre feet of water used to test the facilities should be considered as having been delivered to areas "... not within Western nor tributary to the Riverside Narrows..." Accordingly, the 102 acre foot amount has been shown in Table No. 4.

TABLE NO. 4

VERIFICATION OF EXTRactions FROM THE
SAN BERNARDINO BASIN AREA AND COLTON BASIN AREA
WITHIN THE SAN BERNARDINO VALLEY MUNICIPAL WATER
DISTRICT FOR USE ON LANDS NOT WITHIN
WESTERN NOR TRIBUTARY TO THE RIVERSIDE NARROWS






SAN BERNARDINO VALLEY MUNICIPAL WATER DISTRICT
(Quantities in Acre-Feet)

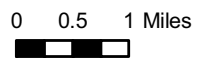
<u>Year</u>	<u>Amount Delivered</u> ¹⁾
1979	119
1980	8
1981	178
1982	625
1983	1,554
1984	321
1985	1,063
1986	486
1987	1,527
1988	1,800
1989	1,048
1990	117
1991	1,166
1992	336
1993	844
1994	2,531
1995	1,236
1996	1,169
1997	200
1998	1,277
1999	109
2000	184
2001	117
2002	210
2003	0
2004	0
2005	0
2006	0
2007	0
2008	102
2009	0
2010	0
2011	0
2012	0

¹⁾ From SBVMWD delivery for specific calendar year, total Mill Creek
Water. In 2008 102 AF of water was banked in Diamond Valley Reservoir.

VOLUME 7 MAP NO. 1

Legend

-  Lands Not Within Western
-  FWCO Well
-  SBVMWD Boundary
-  Basin Area Boundary
-  Fault



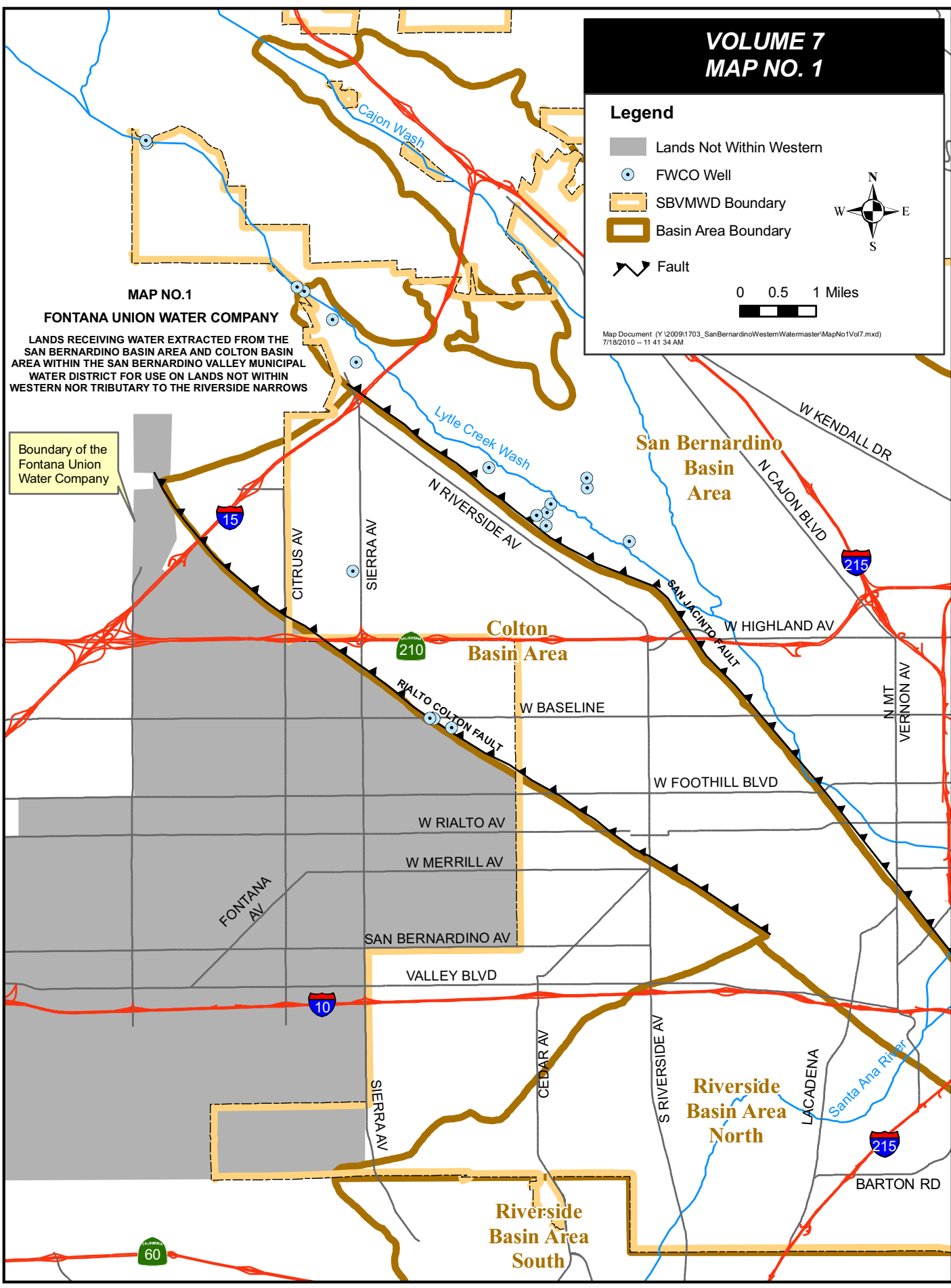
Map Document1 (Y:\2009\1703_SanBernardinoWesternWatermaster\MapNo1Vol7.mxd)
7/19/2010 - 11:41:34 AM

MAP NO.1

FONTANA UNION WATER COMPANY






LANDS RECEIVING WATER EXTRACTED FROM THE SAN BERNARDINO BASIN AREA AND COLTON BASIN AREA WITHIN THE SAN BERNARDINO VALLEY MUNICIPAL WATER DISTRICT FOR USE ON LANDS NOT WITHIN WESTERN NOR TRIBUTARY TO THE RIVERSIDE NARROWS

Boundary of the Fontana Union Water Company



VOLUME 7 MAP NO. 2

Legend

-  WVVW Well
-  Fault
-  SBVMWD Boundary
-  Basin Area Boundary
-  Lands Not Within Western



0 0.5 1 Miles

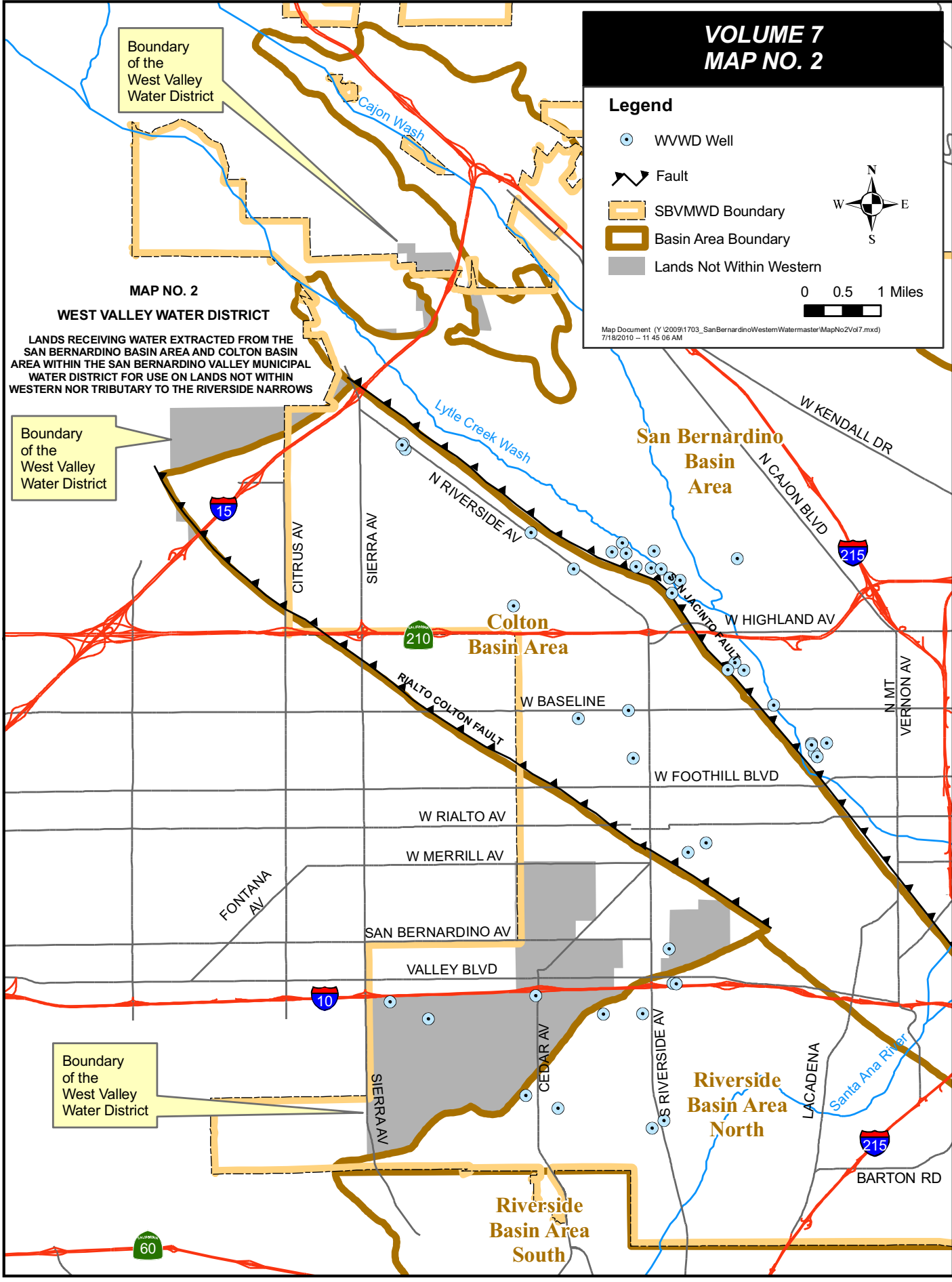
Map Document (Y:\2009\1703_SanBernardinoWesternWatermaster\MapNo2Vol7.mxd)
7/18/2010 - 11:45:06 AM

MAP NO. 2 WEST VALLEY WATER DISTRICT

LANDS RECEIVING WATER EXTRACTED FROM THE SAN BERNARDINO BASIN AREA AND COLTON BASIN AREA WITHIN THE SAN BERNARDINO VALLEY MUNICIPAL WATER DISTRICT FOR USE ON LANDS NOT WITHIN WESTERN NOR TRIBUTARY TO THE RIVERSIDE NARROWS

Boundary of the West Valley Water District

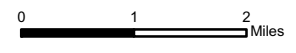
Boundary of the West Valley Water District



VOLUME 7 MAP NO. 3

Legend

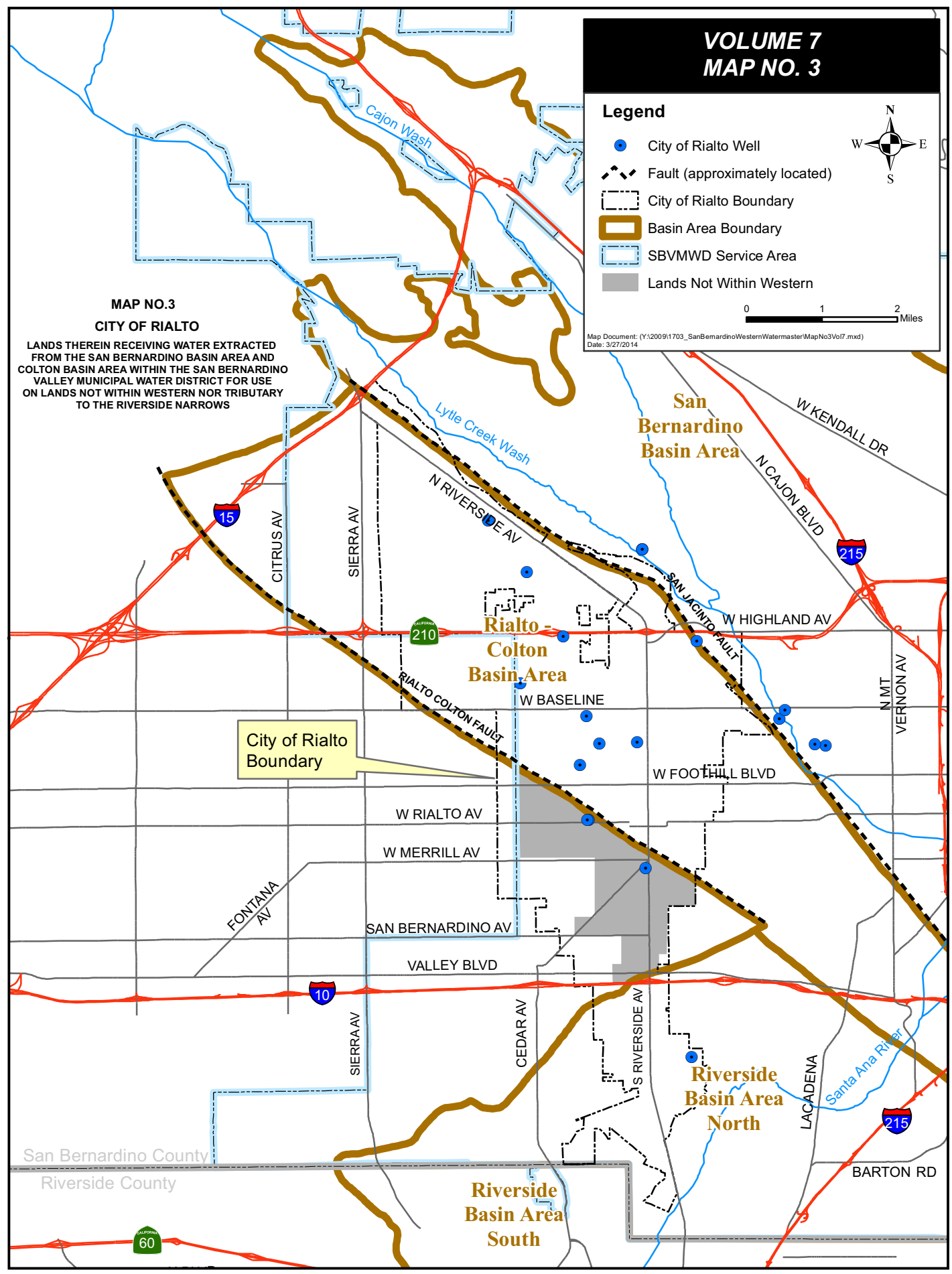
- City of Rialto Well
- Fault (approximately located)
- City of Rialto Boundary
- Basin Area Boundary
- SBVMWD Service Area
- Lands Not Within Western



Map Document: (Y:\2009\1703_SanBernardinoWesternWatermaster\MapNo3Vol7.mxd)
Date: 3/27/2014

MAP NO.3 CITY OF RIALTO

LANDS THEREIN RECEIVING WATER EXTRACTED FROM THE SAN BERNARDINO BASIN AREA AND COLTON BASIN AREA WITHIN THE SAN BERNARDINO VALLEY MUNICIPAL WATER DISTRICT FOR USE ON LANDS NOT WITHIN WESTERN NOR TRIBUTARY TO THE RIVERSIDE NARROWS



City of Rialto Boundary

San Bernardino County
Riverside County

**VOLUME 7
MAP NO. 4**

MAP NO.4

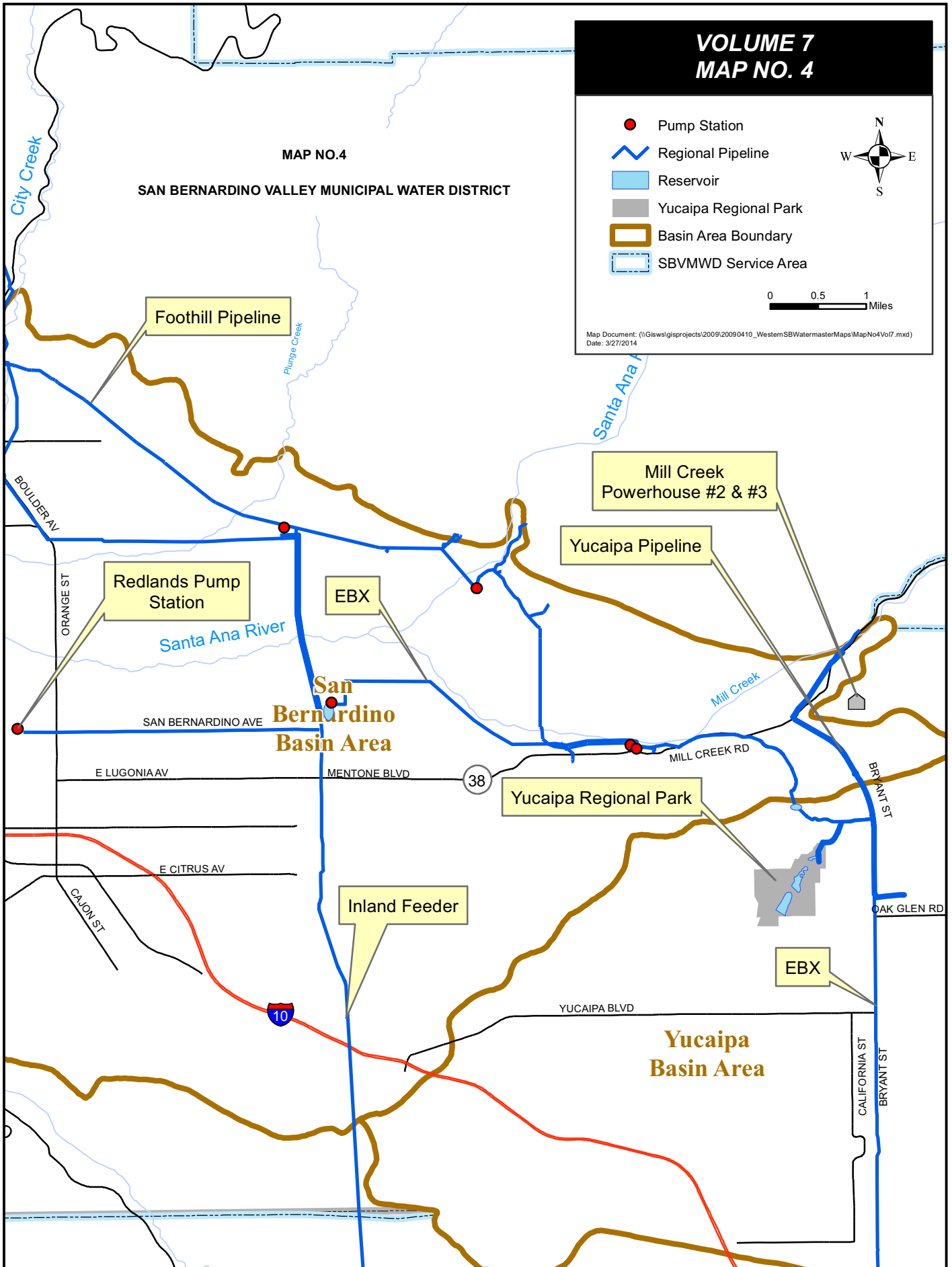
SAN BERNARDINO VALLEY MUNICIPAL WATER DISTRICT

- Pump Station
- Regional Pipeline
- Reservoir
- Yucaipa Regional Park
- Basin Area Boundary
- SBVMWD Service Area



0 0.5 1 Miles

Map Document: (\\gis\gisprojects\2009\20090410_WesternSBWatermasterMaps\MapNo4Vol7.mxd)
Date: 3/27/2014



VOLUME 7-2012

SECTION II

EXPORTS FROM THE SAN BERNARDINO BASIN AREA FOR USE ON
LANDS NOT WITHIN WESTERN NOR TRIBUTARY TO THE
RIVERSIDE NARROWS

CHAPTER III

DELIVERIES TO CHINO BASIN FROM SAN BERNARDINO BASIN AREA

In Section II the deliveries to Chino Basin from San Bernardino Basin Area are determined.

The verified amounts for the base period 1959-1963 are shown in Table C of this report. The verified amounts for calendar years 2008-2012 are shown in Table D. These amounts were determined using data from Section I along with data from other data volumes. Fontana Union Water Company, West Valley Water District and City of Rialto deliver water to areas within Chino Basin. For Fontana Union Water Company, adequate data is contained in Table No. 1 to determine the quantities of water exported from the San Bernardino Basin Area to Chino Basin during the base period 1959-1963 and for calendar year 1971 to present. West Valley Water District has sources of supply from the San Bernardino Basin Area, Colton Basin Area within San Bernardino Valley, Riverside Basin Area within San Bernardino County, and State Water Project water which is treated at the Oliver P. Roemer Water Filtration Facility. A pro-rata share of West Valley Water District's total supply was determined to be produced in the San Bernardino Basin Area and delivered to the Chino Basin. City of Rialto has sources of supply from the San Bernardino Basin Area, Colton Basin Area within San Bernardino Valley, Riverside Basin Area within San Bernardino County, and State Water Project water. The City has also historically purchased water from others prior to availability of water from the San Bernardino Valley Municipal Water District's Baseline Feeder whose source of water is in the San Bernardino Basin Area. A pro-rata share of City of Rialto's total supply was determined to be produced in the San Bernardino Basin Area and delivered to the Chino Basin. Details of individual agency calculations are discussed in the following portions of the report and are shown on Table Nos. 5, 6 and 7. The verified amounts for the base period 1959-1963 are shown in

Table C of this report. The verified amounts for calendar years 2008-2012 are shown in Table D.

TABLE C

DETERMINATION OF EXTRACTATIONS FOR USE ON LANDS
NOT WITHIN WESTERN NOR TRIBUTARY TO THE RIVERSIDE NARROWS FROM
SAN BERNARDINO BASIN AREA

<u>Deliveries to</u>	<u>Source in this Volume</u>	<u>1959-63 Ave.</u> <u>Annual Amount</u>
<u>Areas not within</u>		
<u>Western nor Tributary</u>		
<u>to the Riverside</u>		
<u>Narrows using Prorated</u>		
<u>Extractions from the</u>		
<u>San Bernardino Basin</u>		
<u>Area*</u>		
	<u>Chapter III</u>	
Fontana Water		
Union Company	Table No. 5, Bottom Row	10,170
West Valley		
Water District**	Table No. 6, Bottom Row	1,314
City of Rialto**	Table No. 7, Bottom Row	217
<u>Areas Other Than Chino Basin</u>	<u>Chapter II</u>	
Yucaipa		0
San Timoteo		0
Oak Glen		0
Beaumont		0
Others		0
<hr/>		<hr/>
Total		11,701

* Total Agency supplies were prorated to determine percentage of total supply from San Bernardino Basin Area, Colton Basin Area within San Bernaridno Valley and Riverside Basin Area within San Bernardino County. San Bernardino Basin Area percentage was then applied to total export to Areas Not Within Western nor Tributary to Riverside Narrows (See Table No. A).

** Includes deliveries from Baseline Feeder.

TABLE D

DETERMINATION OF EXTRACTIIONS FOR USE ON LANDS

NOT WITHIN WESTERN NOR TRIBUTARY TO THE RIVERSIDE NARROWS FROM
SAN BERNARDINO BASIN AREA

Deliveries to	Table #	Row #	2008	2009	2010	2011	2012	5 year Average
<u>Areas not within Western nor Tributary to the Riverside Narrows using Prorated Extractions from the San Bernardino Basin Area*</u>								
Fontana Water Union Company	5	Bottom	20,389	15,177	19,421	30,786	18,672	20,889
West Valley Water District**	6	Bottom	6,038	5,592	4,508	3,001	3,374	4,503
City of Rialto**	7	Bottom	1,340	1,272	1,388	900	898	1,160
Subtotal (Delivery to Chino Basin)			27,767	22,041	25,317	34,687	22,944	26,552
Areas Other Than Chino Basin								
Yucaipa	4	2						0
San Timoteo								0
Oak Glen								0
Beaumont								0
Others	4	2	102					20
Subtotal (Delivery to other than Chino Basin)			102	0	0	0	0	20
Total Water Delivery			27,869	22,041	25,317	34,687	22,944	26,572

* Total Agency supplies were prorated to determine percentage of total supply from San Bernardino Basin Area, Colton Basin Area within San Bernardino Valley and Riverside Basin Area within San Bernardino County. San Bernardino Basin Area percentage was then applied to total export to Areas Not Within Western nor Tributary to Riverside Narrows (See Table B).

** Includes deliveries from Baseline Feeder.

FONTANA UNION WATER COMPANY

During the base period 1959-1963 Fontana Union Water Company produced water from the San Bernardino Basin Area and the Colton Basin Area within San Bernardino Valley. Using data from Table No. 1, Table No. 5 shows extractions from the San Bernardino Basin Area and Colton Basin Area within San Bernardino Valley during the base period 1959-1963. It also shows deliveries made in the San Bernardino Basin Area and Colton Basin Area within San Bernardino Valley. Using these data, an average annual quantity of water exported from the San Bernardino Basin Area to the Chino Basin was determined for the base period 1959-1963.

Using data from Table No. 1, Table No. 5 also shows extractions from the San Bernardino Basin Area and Colton Basin Area within San Bernardino Valley during calendar years 2008-2012. It also shows deliveries made in the San Bernardino Basin Area and Colton Basin Area within San Bernardino Valley (to the extent such information is provided by Fontana Water Company). Using these data, an average annual quantity of water exported from the San Bernardino Basin Area to the Chino Basin was determined for calendar years 2008-2012.

TABLE NO. 5

DETERMINATION OF DELIVERIES FOR USE ON LANDS
NOT WITHIN WESTERN NOR TRIBUTARY TO THE RIVERSIDE NARROWS FROM
SAN BERNARDINO BASIN AREA

FONTANA UNION WATER COMPANY
(Quantities in Acre Feet)

	1959	1960	1961	1962	1963	5-yr Ave.	2008	2009	2010	2011	2012	5-yr Ave.
(1) San Bernardino Basin Area (SBBA) Production - V7T1/V7T1												
(2) Wells	9,169	6,671	5,968	3,521	2,779	5,622	10,523	7,789	7,074	9,574	12,605	9,513
(3) Surface Water	7,964	5,344	3,864	8,225	5,692	6,218	10,146	7,720	12,858	21,620	6,582	11,785
(4) Breed Line	501	521	413	526	522	496	0	0	0	0	0	0
(5) Total SBBA Production	17,634	12,536	10,245	12,272	8,993	12,336	20,669	15,509	19,932	31,194	19,187	21,298
(6) SBBA Deliveries - V7T1/V7T1												
(7) CEMEX	323	491	417	481	446	432	280	332	511	408	515	409
(8) City of San Bernardino	1,393	1,396	1,765	746	726	1,205	0	0	0	0	0	0
(9) Total SBBA Deliveries	1,716	1,887	2,182	1,227	1,172	1,637	280	332	511	408	515	409
(10) Net SBBA Production Exported	15,918	10,649	8,063	11,045	7,821	10,699	20,389	15,177	19,421	30,786	18,672	20,889
(11) Colton Basin Area within San Bernardino Valley (CBA) Extractions - V7T1/V7T1												
(12) Wells	31	31	31	31	31	31	0	0	0	0	0	0
(13) Total CBA Production	31	31	31	31	31	31	0	0	0	0	0	0
(14) CBA Deliveries - V7T1/V7T1*												
(15) Citrus	700	600	600	500	400	560	0	0	0	0	0	0
(16) City of Rialto	0	0	0	0	0	0	0	0	0	0	0	0
(17) Total CBA Deliveries	700	600	600	500	400	560	0	0	0	0	0	0
(18) SBBA Production Delivered for use on lands not within Western nor tributary to the Riverside Narrows = (10)+(13)-(17)	15,249	10,080	7,494	10,576	7,452	10,170	20,389	15,177	19,421	30,786	18,672	20,889

* Fontana Water Company delivers water extracted from San Bernardino Basin Area and Colton Basin Area as Fontana Union Water Company. The Fontana Water Company water service area is located largely within Chino Basin. However, portions of the Fontana Water Company service area are within Colton Basin Area. Records of the deliveries within the Colton Basin Area are not available to the Watermaster.

WEST VALLEY WATER DISTRICT

During the base period 1959-1963 West Valley Water District produced water from the San Bernardino Basin Area, the Colton Basin Area within San Bernardino Valley and the Riverside Basin Area within San Bernardino County for export to Chino Basin. Table No. 6 shows Total Extractions/Supply from the San Bernardino Basin Area, the Colton Basin Area within San Bernardino Valley and the Riverside Basin Area within San Bernardino County during the base period 1959-1963. From these values, the percentage of West Valley Water District's water produced from the San Bernardino Basin Area was determined. That percentage was applied to the total West Valley Water District deliveries to the Chino Basin to determine the pro-rata share of San Bernardino Basin Area water delivered to the Chino Basin for each year. An average annual quantity was determined for the base period 1959-1963.

Table No. 6 also shows Total Extractions/Supply from the San Bernardino Basin Area, the Colton Basin Area within San Bernardino Valley, the Riverside Basin Area within San Bernardino County, and State Water Project water during calendar years 2008-2012. From these values, the percentage of West Valley Water District's water produced from the San Bernardino Basin Area was determined for each year. That percentage was applied to the total West Valley Water District deliveries to the Chino Basin to determine the pro-rata share of San Bernardino Basin Area water delivered to the Chino Basin in each year. An average annual quantity was determined for calendar years 2008-2012.

TABLE NO. 6

DETERMINATION OF DELIVERIES FOR USE ON LANDS
 NOT WITHIN WESTERN NOR TRIBUTARY TO THE RIVERSIDE NARROWS FROM
 SAN BERNARDINO BASIN AREA BASED ON TOTAL SUPPLY FROM
 SAN BERNARDINO BASIN AREA, COLTON BASIN AREA WITHIN SAN BERNARDINO VALLEY,
 RIVERSIDE BASIN AREA WITHIN SAN BERNARDINO COUNTY, AND
 STATE WATER PROJECT WATER
 WEST VALLEY WATER DISTRICT
 (Quantities in Acre Feet)

	1959	1960	1961	1962	1963	5-yr Ave.	2008	2009	2010	2011	2012	5-yr Ave.
San Bernardino Basin Area (SBBA) Extractions - VIT3/VIT3	13,584	12,090	13,587	11,331	11,837	12,486	13,754	12,716	7,986	7,697	8,637	10,158
SBBA Baseline Feeder supply							2,747	2,568	2,431	2,628	2,065	2,488
subtract return from WWD Division Box							0	0	0	0	0	0
SBBA Total Supply	13,584	12,090	13,587	11,331	11,837	12,486	16,501	15,284	10,417	10,325	10,702	12,646
Colton Basin Area within San Bernardino Valley Extractions - V2T3/V2T3	3,235	4,195	4,173	3,040	2,769	3,482	2,751	3,741	5,336	4,883	4,093	4,161
Riverside Basin Area within San Bernardino County Extractions - V3T3/V3T3	1,209	1,325	1,282	1,164	975	1,191	2,269	938	0	1,073	2,085	1,273
State Water Project water							860	193	8	403	849	463
Total Extractions/Supply	18,028	17,610	19,042	15,535	15,581	17,159	22,381	20,156	15,761	16,684	17,729	18,542
San Bernardino Basin Area Percentage	75.349%	68.654%	71.353%	72.939%	75.971%	72.766%	73.728%	75.829%	66.094%	61.886%	60.364%	67.600%
Colton Basin Area within San Bernardino Valley Percentage	17.944%	23.822%	21.915%	19.569%	17.772%	20.293%	12.292%	18.560%	33.856%	29.268%	23.086%	23.400%
Riverside Basin Area within San Bernardino County Percentage	6.706%	7.524%	6.732%	7.493%	6.258%	6.941%	10.138%	4.654%	0.000%	6.431%	11.760%	6.600%
State Water Project water Percentage	0.000%	0.000%	0.000%	0.000%	0.000%	0.000%	3.843%	0.958%	0.051%	2.415%	4.789%	2.400%
Total Percentage	100.000%	100.000%	100.000%	100.000%	100.000%	100.000%	100.000%	100.000%	100.000%	100.000%	100.000%	100.000%
Total Deliveries for Use on Lands not within Western nor Tributary to the Riverside Narrows V7T2/V7T2	2,239	1,726	2,032	1,641	1,389	1,806	8,189	7,374	6,820	4,850	5,590	6,565
Prorated Deliveries for Use on Lands not within Western nor Tributary to the Riverside Narrows from San Bernardino Basin Area	1,687	1,185	1,450	1,197	1,055	1,314	6,038	5,592	4,508	3,001	3,374	4,503

CITY OF RIALTO

During the base period 1959-1963 City of Rialto produced water from the San Bernardino Basin Area and the Colton Basin Area within San Bernardino Valley for export to Chino Basin. Table No. 7 shows Total Extractions/Supply from the San Bernardino Basin Area, Colton Basin Area within San Bernardino Valley, Riverside Basin Area within San Bernardino County and State Water Project water during the base period 1959-1963. From these values, the percentage of City of Rialto's water produced from the San Bernardino Basin Area was determined. That percentage was applied to the total City of Rialto deliveries to the Chino Basin to determine the pro-rata share of San Bernardino Basin Area water delivered to the Chino Basin for each year. An average annual quantity was determined for the base period 1959-1963.

Table No. 7 also shows Total Extractions/Supply from the San Bernardino Basin Area, Colton Basin Area within San Bernardino Valley, Riverside Basin Area within San Bernardino County, and State Water Project water during calendar years 2008-2012. From these values, the percentage of City of Rialto's water produced from the San Bernardino Basin Area was determined for each year. That percentage was applied to the total City of Rialto deliveries to the Chino Basin to determine the pro-rata share of San Bernardino Basin Area water delivered to the Chino Basin in each year. An average annual quantity was determined for calendar years 2008-2012.

TABLE NO. 7

DETERMINATION OF DELIVERIES FOR USE ON LANDS
 NOT WITHIN WESTERN NOR TRIBUTARY TO THE RIVERSIDE NARROWS FROM
 SAN BERNARDINO BASIN AREA BASED ON TOTAL SUPPLY FROM
 SAN BERNARDINO BASIN AREA, COLTON BASIN AREA WITHIN SAN BERNARDINO VALLEY AND
 RIVERSIDE BASIN AREA WITHIN SAN BERNARDINO COUNTY

CITY OF RIALTO
 (Quantities in Acre Feet)

	1959	1960	1961	1962	1963	5-Yr Ave.	2008	2009	2010	2011	2012	5-Yr Ave.
San Bernardino Basin Area												
(SBBA) Extractions -												
V7T3/V1T3 Column 2 +		794	906	1,068	1,157	1,075	6,545	5,713	5,325	3,377	3,102	4,812
Column 3	1,450						3,403	3,611	2,580	4,030	4,730	3,671
SBBA Baseline Feeder supply		794	906	1,068	1,157	1,075	9,948	9,324	7,905	7,407	7,832	8,483
SBBA Total Supply	1,450											
Colton Basin Area within												
San Bernardino Valley												
Extractions - V2T3/V2T3	1,147	1,243	1,874	1,873	2,139	1,655	2,352	3,219	2,782	2,206	2,771	2,666
Riverside Basin Area												
within San Bernardino												
County Extractions -												
V3T3/V3T3 excluding												
3601680	0	0	0	0	0	0	0	0	0	0	0	0
State Water Project water												
Total Extractions/Supply	2,597	2,037	2,780	2,941	3,296	2,730	12,300	12,543	10,687	9,613	10,603	11,149
San Bernardino Basin Area												
Percentage	55.834%	38.979%	32.590%	36.314%	35.103%	39.377%	80.878%	74.336%	73.968%	77.052%	73.866%	76.000%
Colton Basin Area within												
San Bernardino Valley												
Percentage	44.166%	61.021%	67.410%	63.686%	64.897%	60.623%	19.122%	25.664%	26.032%	22.948%	26.134%	24.000%
Riverside Basin Area												
within San Bernardino												
County Percentage	0.000%	0.000%	0.000%	0.000%	0.000%	0.000%	0.000%	0.000%	0.000%	0.000%	0.000%	0.000%
State Water Project water												
percentage	0.000%	0.000%	0.000%	0.000%	0.000%	0.000%	0.000%	0.000%	0.000%	0.000%	0.000%	0.000%
Total Percentage	100.000%	100.000%	100.000%	100.000%	100.000%	100.000%	100.000%	100.000%	100.000%	100.000%	100.000%	100.000%
Total Deliveries for Use												
on Lands not within												
Western nor Tributary to												
the Riverside Narrows												
V7T3/V7T3	575	553	555	552	518	551	1,657	1,711	1,877	1,168	1,216	1,526
Prorated Deliveries for												
Use on Lands not within												
Western nor Tributary to												
the Riverside Narrows												
from San Bernardino Basin												
Area	321	216	181	200	182	217	1,340	1,272	1,388	900	898	1,160

VOLUME 7-2012

SECTION III

DELIVERIES FROM THE SAN BERNARDINO BASIN AREA FOR USE
ON LANDS WITHIN THE COLTON BASIN AREA WITHIN
SAN BERNARDINO VALLEY AND RIVERSIDE BASIN AREA WITHIN
SAN BERNARDINO COUNTY

CHAPTER IV

In Section III the deliveries from San Bernardino Basin Area for use on lands within the Colton Basin Area with San Bernardino Valley and Riverside Basin Area within San Bernardino County are determined.

The verified amounts for the base period 1959-1963 are shown in Table E of this report. The verified amounts for calendar years 2008-2012 are shown in Table F. These amounts were determined using data from Section II along with data from other data volumes.

TABLE E

DETERMINATION OF DELIVERIES FROM THE SAN BERNARDINO BASIN AREA
FOR USE ON LANDS IN COLTON BASIN AREA WITHIN SAN BERNARDINO VALLEY
AND RIVERSIDE BASIN AREA WITHIN SAN BERNARDINO COUNTY

<u>Deliveries to</u>	<u>Source in this Volume</u>	<u>1959-63 Ave. Annual Amount</u>
<u>Lands in Colton Basin Area within San Bernardino Valley and Riverside Basin Area within San Bernardino County</u>	<u>Chapter IV</u>	
Fontana Water Union Company	Table No. 8, Bottom Row	529
West Valley Water District	Table No. 9, Bottom Row	11,172
City of Rialto	Table No. 10, Bottom Row	858
City of Colton	Table No. 11, Bottom Row	3,347
City of San Bernardino Elevated System	Table No. 12, Bottom Row	886
<u>Terrace Water Company</u>	<u>Table No. 13, Bottom Row</u>	<u>1,045</u>
Average Total Deliveries		17,837

TABLE F

DETERMINATION OF DELIVERIES FROM THE SAN BERNARDINO BASIN AREA
FOR USE ON LANDS IN THE COLTON BASIN AREA WITHIN SAN BERNARDINO VALLEY
AND RIVERSIDE BASIN AREA WITHIN SAN BERNARDINO COUNTY,
INCREASED DELIVERIES THERETO, AND
INCREASED RETURN FLOW THERETO

<u>Deliveries to</u>	<u>Table #</u>	<u>Row #</u>	<u>2008</u>	<u>2009</u>	<u>2010</u>	<u>2011</u>	<u>2012</u>	<u>5 year Average</u>
<u>Lands in the Colton Basin Area within San Bernardino Valley and Riverside Basin Area within San Bernardino County</u>								
Fontana Water Union Company	8	Bottom	0	0	0	0	0	0
West Valley Water District	9	Bottom	10,463	9,692	5,909	7,324	6,811	8,040
City of Rialto	10	Bottom	8,608	8,052	6,517	6,507	6,934	7,324
City of Colton	11	Bottom	6,917	6,334	4,740	4,783	6,222	5,799
City of San Bernardino Elevated System	12	Bottom	2,970	2,785	2,697	2,722	2,853	2,805
Terrace Water Company	13	Bottom	813	788	701	706	751	752
Total Deliveries			29,771	27,651	20,564	22,042	23,571	24,720
1959-63 Average Total Deliveries	E	Bottom	17,837	17,837	17,837	17,837	17,837	17,837
Increased Deliveries			11,934	9,814	2,727	4,205	5,734	6,883
Return Flow from Increased Deliveries			4,296	3,533	982	1,514	2,064	2,478

FONTANA UNION WATER COMPANY

During the base period 1959-1963 Fontana Union Water Company produced water from the San Bernardino Basin Area and the Colton Basin Area within San Bernardino Valley Municipal Water District. Using data from Table No. 1, Table No. 8 shows extractions from the San Bernardino Basin Area and Colton Basin Area within San Bernardino Valley during the base period 1959-1963. It also shows deliveries made in the San Bernardino Basin Area and Colton Basin Area within San Bernardino Valley. Using these data, an average annual quantity of water from the San Bernardino Basin Area delivered for use on lands within the Colton Basin Area within San Bernardino Valley and Riverside Basin Area within San Bernardino County was determined for the base period 1959-1963.

Using data from Table No. 1, Table No. 8 also shows extractions from the San Bernardino Basin Area and Colton Basin Area within San Bernardino Valley during calendar years 2008-2012. It also shows deliveries made in the San Bernardino Basin Area and Colton Basin Area within San Bernardino Valley (to the extent such information is provided by Fontana Water Company). Using these data, an average annual quantity of water from the San Bernardino Basin Area delivered for use on lands within the Colton Basin Area within San Bernardino Valley and Riverside Basin Area within San Bernardino County was determined for calendar years 2008-2012.

TABLE NO. 8

DETERMINATION OF EXTRACTIIONS FROM THE SAN BERNARDINO BASIN AREA
FOR USE ON LANDS WITHIN THE COLTON BASIN AREA WITHIN SAN BERNARDINO VALLEY
AND RIVERSIDE BASIN AREA WITHIN SAN BERNARDINO COUNTY

FONTANA UNION WATER COMPANY
(Quantities in Acre Feet)

	1959	1960	1961	1962	1963	5-yr Ave.	2008	2009	2010	2011	2012	5-yr Ave.
(1) San Bernardino Basin Area (SBBA) Production - V7T1/V7T1												
(2) Wells	9,169	6,671	5,968	3,521	2,779	5,622	10,523	7,789	7,074	9,574	12,605	9,513
(3) Surface Water	7,964	5,344	3,864	8,225	5,692	6,218	10,146	7,720	12,858	21,620	6,582	11,785
(4) Breed Line	501	521	413	526	522	496	0	0	0	0	0	0
(5) Total SBBA Production	17,634	12,536	10,245	12,272	8,993	12,336	20,669	15,509	19,932	31,194	19,187	21,298
(6) SBBA Deliveries - V7T1/V7T1												
(7) CEMEX	323	491	417	481	446	432	280	332	511	408	515	409
(8) City of San Bernardino	1,393	1,396	1,765	746	726	1,205	0	0	0	0	0	0
(9) Total SBBA Deliveries	1,716	1,887	2,182	1,227	1,172	1,637	280	332	511	408	515	409
(10) Net SBBA Production Exported	15,918	10,649	8,063	11,045	7,821	10,699	20,389	15,177	19,421	30,786	18,672	20,889
(11) Colton Basin Area within San Bernardino Valley (CBA) Extractions - V7T1/V7T1												
(12) Wells	31	31	31	31	31	31	0	0	0	0	0	0
(13) Total CBA Production	31	31	31	31	31	31	0	0	0	0	0	0
(14) CBA Deliveries - V7T1/V7T1*												
(15) Citrus	700	600	600	500	400	560	0	0	0	0	0	0
(16) City of Rialto	0	0	0	0	0	0	0	0	0	0	0	0
(17) Total CBA Deliveries	700	600	600	500	400	560						
(18) SBBA Production Delivered to Colton Basin Area = (17) - (13)	669	569	569	469	369	529	0	0	0	0	0	0

*Fontana Water Company delivers water extracted from San Bernardino Basin Area and Colton Basin Area as Fontana Union Water Company. The Fontana Water Company water service area is located largely within Chino Basin. However, portions of the Fontana Water Company service area are within Colton Basin Area. Records of the deliveries within the Colton Basin Area are not available to the Wesern-San Bernardino Watermaster.

WEST VALLEY WATER DISTRICT

During the base period 1959-1963 West Valley Water District produced water from the San Bernardino Basin Area for use in the San Bernardino Basin Area and for use on lands in the Colton Basin Area within San Bernardino Valley and Riverside Basin Area within San Bernardino County. A portion of the San Bernardino Basin Area production was used within the San Bernardino Basin Area. Table No. 9 shows Total Extractions from the San Bernardino Basin Area, deliveries in the San Bernardino Basin Area, and deliveries to Chino Basin from Table No. 6 during the base period 1959-1963. From these values, West Valley Water District's deliveries for use on lands within the Colton Basin Area within San Bernardino Valley and Riverside Basin Area within San Bernardino County were determined for each year. An average annual quantity was determined for the base period 1959-1963.

Table No. 9 also shows Total Extractions from the San Bernardino Basin Area, deliveries in the San Bernardino Basin Area, and deliveries to Chino Basin from Table No. 6 during calendar years 2008-2012. From these values, West Valley Water District's deliveries for use on lands within the Colton Basin Area within San Bernardino Valley and Riverside Basin Area within San Bernardino County were determined for each year. An average annual quantity was determined for calendar years 2008-2012.

TABLE NO. 9
DETERMINATION OF EXTRACTIIONS FROM THE SAN BERNARDINO BASIN AREA
FOR USE ON LANDS WITHIN THE COLTON BASIN AREA WITHIN SAN BERNARDINO VALLEY
AND RIVERSIDE BASIN AREA WITHIN SAN BERNARDINO COUNTY

WEST VALLEY WATER DISTRICT
(Quantities in Acre Feet)

	1959	1960	1961	1962	1963	5-yr Ave.	2008	2009	2010	2011	2012	5-yr Ave.
San Bernardino Basin Area (SBBA) Extractions from Table 6	13,584	12,090	13,587	11,331	11,837	12,486	16,501	15,284	10,417	10,325	10,702	12,646
San Bernardino Basin Area Deliveries	0	0	0	0	0	0	0	0	0	0	517	103
San Bernardino Basin Area Deliveries for Use on Lands not within Western nor Tributary to the Riverside Narrows from Table 6	1,687	1,185	1,450	1,197	1,055	1,314	6,038	5,592	4,508	3,001	3,374	4,503
San Bernardino Basin Area Deliveries to Colton Basin Area within San Bernardino Valley (1)	11,897	10,905	12,137	10,134	10,782	11,172	10,463	9,692	5,909	7,324	6,811	8,040

(1) = SBBA Extractions from Table 6 minus SBBA Deliveries minus SBBA Deliveries for Use on Lands not within Western nor Tributary to the Riverside Narrows from Table 6

CITY OF RIALTO

During the base period 1959-1963 City of Rialto produced water from the San Bernardino Basin Area for use on lands in the Colton Basin Area within San Bernardino Valley and Riverside Basin Area within San Bernardino County. Table No. 10 shows Total Extractions from the San Bernardino Basin Area and deliveries to Chino Basin from Table No. 7 during the base period 1959-1963. From these values, City of Rialto's deliveries for use on lands within the Colton Basin Area within San Bernardino Valley and Riverside Basin Area within San Bernardino County were determined for each year. An average annual quantity was determined for the base period 1959-1963.

Table No. 10 also shows Total Extractions from the San Bernardino Basin Area and deliveries to Chino Basin from Table No. 7 during calendar years 2008-2012. From these values, City of Rialto's deliveries for use on lands within the Colton Basin Area within San Bernardino Valley and Riverside Basin Area within San Bernardino County were determined for each year. An average annual quantity was determined for calendar years 2008-2012.

TABLE NO. 10

DETERMINATION OF EXTRACTIONS FROM THE SAN BERNARDINO BASIN AREA
 FOR USE ON LANDS WITHIN THE COLTON BASIN AREA WITHIN SAN BERNARDINO VALLEY
 AND RIVERSIDE BASIN AREA WITHIN SAN BERNARDINO COUNTY

CITY OF RIALTO

(Quantities in Acre Feet)

	1959	1960	1961	1962	1963	5-yr Ave.	2008	2009	2010	2011	2012	5-yr Ave.
San Bernardino Basin Area (SBBA) Extractions from Table 7	1,450	794	906	1,068	1,157	1,075	9,948	9,324	7,905	7,407	7,832	8,483
San Bernardino Basin Area Deliveries for Use on Lands not within Western nor Tributary to the Riverside Narrows from Table 7	321	216	181	200	182	217	1,340	1,272	1,388	900	898	1,160
San Bernardino Basin Area Deliveries to Colton Basin Area within San Bernardino Valley (1)	1,129	578	725	868	975	858	8,608	8,052	6,517	6,507	6,934	7,324

(1) = SBBA Extractions from Table 7 minus SBBA Deliveries for Use on Lands not within Western nor Tributary to the Riverside Narrows

CITY OF COLTON

During the base period 1959-1963 City of Colton produced water from the San Bernardino Basin Area for use on lands in the Colton Basin Area within San Bernardino Valley and Riverside Basin Area within San Bernardino County. Table No. 11 shows Total Extractions from the San Bernardino Basin Area by City of Colton. An average annual quantity was determined for the base period 1959-1963.

Table No. 11 also shows Total Extractions from the San Bernardino Basin Area by City of Colton during calendar years 2008-2012. City of Colton's extractions from the San Bernardino Basin Area were determined to have been delivered for use on lands within the Colton Basin Area within San Bernardino Valley and Riverside Basin Area within San Bernardino County during each year. An average annual quantity was determined for calendar years 2008-2012.

TABLE NO. 11

DETERMINATION OF EXTRACTIONS FROM THE SAN BERNARDINO BASIN AREA
FOR USE ON LANDS WITHIN THE COLTON BASIN AREA WITHIN SAN BERNARDINO VALLEY
AND RIVERSIDE BASIN AREA WITHIN SAN BERNARDINO COUNTY
CITY OF COLTON

(Quantities in Acre Feet)

	1959	1960	1961	1962	1963	5-yr Ave.	2008	2009	2010	2011	2012	5-yr Ave.
City of Colton San Bernardino Basin Area Production - VIT3	2,814	3,606	3,305	3,743	3,267	3,347	6,917	6,334	4,740	4,783	6,222	5,799

CITY OF SAN BERNARDINO ELEVATED SYSTEM

During the base period 1959-1963 City of San Bernardino produced water from the San Bernardino Basin Area for delivery to its Elevated System for use on lands within the Colton Basin Area within San Bernardino Valley. Table No. 12 shows Total Extractions from the San Bernardino Basin Area delivered by City of Bernardino to its Elevated System for use on lands within the Colton Basin Area within San Bernardino Valley for each year. An average annual quantity was determined for the base period 1959-1963.

Table No. 12 also shows City of San Bernardino Extractions from the San Bernardino Basin Area delivered by City of San Bernardino to its Elevated System for use on lands within the Colton Basin Area within San Bernardino Valley for each year. An average annual quantity was determined for calendar years 2008-2012.

TABLE NO. 12

DETERMINATION OF EXTRACTIIONS FROM THE SAN BERNARDINO BASIN AREA
FOR USE ON LANDS WITHIN THE COLTON BASIN AREA WITHIN SAN BERNARDINO VALLEY
AND RIVERSIDE BASIN AREA WITHIN SAN BERNARDINO COUNTY
CITY OF SAN BERNARDINO ELEVATED SYSTEM
(Quantities in Acre Feet)

	1959	1960	1961	1962	1963	2008	2009	2010	2011	2012	5-yr Ave.
802	854	955	940	878	886	2,970	2,785	2,697	2,722	2,853	2,805

City of San Bernardino
Elevated System - San
Bernardino Municipal
Water Department data

TERRACE WATER COMPANY

During the base period 1959-1963 Terrace Water Company produced water from the San Bernardino Basin Area for use on lands within the Colton Basin Area within San Bernardino Valley and Riverside Basin Area within San Bernardino County. Table No. 13 shows Total Extractions from the San Bernardino Basin Area by Terrace Water Company. An average annual quantity was determined for the base period 1959-1963.

Table No. 13 also shows Total Extractions from the San Bernardino Basin Area by Terrace Water Company during calendar years 2008-2012. Terrace Water Company's extractions from the San Bernardino Basin Area were determined to have been delivered for use on lands within the Colton Basin Area within San Bernardino Valley and Riverside Basin Area within San Bernardino County during each year. An average annual quantity was determined for calendar years 2008-2012.

TABLE NO. 13

DETERMINATION OF EXTRACTIONS FROM THE SAN BERNARDINO BASIN AREA
 FOR USE ON LANDS WITHIN THE COLTON BASIN AREA WITHIN SAN BERNARDINO VALLEY
 AND RIVERSIDE BASIN AREA WITHIN SAN BERNARDINO COUNTY
 TERRACE WATER COMPANY
 (Quantities in Acre Feet)

	1959	1960	1961	1962	1963	5-yr Ave.	2008	2009	2010	2011	2012	5-yr Ave.
Terrace Water Company San Bernardino Basin Area Extractions - VIT3	1,318	921	1,077	1,012	899	1,045	813	788	701	706	751	752

VOLUME 7-2012

SECTION IV

LOSS OF RETURN FLOW RELATED TO INCREASED DELIVERIES
FROM
COLTON BASIN AREA WITHIN SAN BERNARDINO VALLEY AND
RIVERSIDE BASIN AREA WITHIN SAN BERNARDINO COUNTY
FOR USE ON LANDS NOT WITHIN WESTERN NOR TRIBUTARY TO
THE RIVERSIDE NARROWS

AND

CREDIT FOR INCREASED RETURN FLOW RELATED TO
NEW DELIVERIES OF WATER
FROM OUTSIDE THE BASINS TO
COLTON BASIN AREA WITHIN SAN BERNARDINO VALLEY AND
RIVERSIDE BASIN AREA WITHIN SAN BERNARDINO COUNTY

CHAPTER V

INCREASED DELIVERIES FROM THE COLTON BASIN AREA WITHIN SAN
BERNARDINO VALLEY FOR USE ON LANDS NOT WITHIN WESTERN NOR
TRIBUTARY TO THE RIVERSIDE NARROWS, AND LOSS OF RETURN FLOW
RELATED TO SUCH INCREASED DELIVERIES

In Chapter V the increased deliveries from Colton Basin Area within San Bernardino Valley for use on lands not within Western nor Tributary to the Riverside Narrows and resulting loss of return flow from Colton Basin Area within San Bernardino Valley are determined.

The verified amounts for the base period 1959-1963 are shown in Table G of this report. The verified amounts for calendar years 2008-2012 are shown in Table H. These amounts were determined using data as detailed in the notes on the subsidiary tables.

TABLE G

DETERMINATION OF DELIVERIES FROM THE COLTON BASIN AREA
WITHIN SAN BERNARDINO VALLEY FOR USE ON LANDS NOT
WITHIN WESTERN NOR TRIBUTARY TO THE RIVERSIDE NARROWS
(1959-1963)

<u>Deliveries to</u>	<u>Source in this Volume</u>	<u>1959-63 Ave.</u> <u>Annual Amount</u>
<u>Lands Not Within</u> <u>Western nor Tributary</u> <u>to the Riverside</u> <u>Narrows</u>	<u>Chapter IV</u>	
Fontana Water Union Company	Table No. 14, Bottom Row	0
West Valley Water District	Table No. 15, Bottom Row	366
<u>City of Rialto</u>	Table No. 16, Bottom Row	334
Average Total Deliveries		700

TABLE H

DETERMINATION OF INCREASED DELIVERIES FROM THE COLTON
BASIN AREA WITHIN SAN BERNARDINO VALLEY FOR USE ON
LANDS NOT WITHIN WESTERN NOR TRIBUTARY TO THE RIVERSIDE NARROWS, AND
LOSS OF RETURN FLOW RELATED TO SUCH INCREASED DELIVERIES

<u>Deliveries to</u>	<u>Table #</u>	<u>Row #</u>	<u>2008</u>	<u>2009</u>	<u>2010</u>	<u>2011</u>	<u>2012</u>	<u>5 Year Average</u>
<u>Lands Not Within Western nor Tributary to the Riverside Narrows</u>								
Fontana Water Union Company	14	Bottom	0	0	0	0	0	0
West Valley Water District	15	Bottom	1,007	1,369	2,309	1,419	1,291	1,479
City of Rialto	16	Bottom	317	439	489	268	318	366
Total Deliveries			1,324	1,808	2,798	1,687	1,609	1,845
1959-63 Average Total Deliveries			700	700	700	700	700	700
Increased Deliveries			624	1,108	2,098	987	909	1,145
Loss of Return Flow related to Increased Deliveries			225	399	755	355	327	412

FONTANA UNION WATER COMPANY

During the base period 1959-1963 Fontana Union Water Company produced water from the Colton Basin Area within San Bernardino Valley Municipal Water District. Using data from Table No. 1, Table No. 14 shows extractions from the Colton Basin Area within San Bernardino Valley during the base period 1959-1963. It also shows deliveries for use on lands not within Western nor tributary to the Riverside Narrows. Using these data, an average annual quantity of water from the Colton Basin Area within San Bernardino Valley and delivered for use on lands not within Western nor tributary to the Riverside Narrows was determined for the base period 1959-1963.

Using data from Table No. 1, Table No. 14 also shows extractions from the Colton Basin Area within San Bernardino Valley during calendar years 2008-2012. Using these data, an average annual quantity of water from the Colton Basin Area within San Bernardino Valley delivered for use on lands not within Western nor tributary to the Riverside Narrows was determined for calendar years 2008-2012.

TABLE NO. 14

DETERMINATION OF DELIVERIES FROM THE COLTON BASIN AREA
 WITHIN SAN BERNARDINO VALLEY FOR USE ON LANDS NOT
 WITHIN WESTERN NOR TRIBUTARY TO THE RIVERSIDE NARROWS

FONTANA UNION WATER COMPANY
 (Quantities in Acre Feet)

	1959	1960	1961	1962	1963	5-yr Ave.	2008	2009	2010	2011	2012	5-yr Ave.
Colton Basin Area within												
(1) San Bernardino Valley (CBA) Extractions - V7T1/V7T1	31	31	31	31	31	31	0	0	0	0	0	0
(2) Wells	31	31	31	31	31	31	0	0	0	0	0	0
(3) Total CBA Production	31	31	31	31	31	31	0	0	0	0	0	0
CBA Deliveries -												
(4) V7T1/V7T1*												
(5) Citrus	700	600	600	500	400	560	0	0	0	0	0	0
(6) City of Rialto	0	0	0	0	0	0	0	0	0	0	0	0
(7) Total CBA Deliveries	700	600	600	500	400	560	0	0	0	0	0	0

CBA Production Delivered
 for Use on Lands not
 within Western nor
 Tributary to the
 Riverside Narrows
 = (3) - (7),
 = 0 if negative

* Fontana Water Company delivers water extracted from San Bernardino Basin Area and Colton Basin Area as Fontana Union Water Company. The Fontana Water Company water service area is located largely within Chino Basin. However, portions of the Fontana Water Company service area are within Colton Basin Area. Records of the deliveries within the Colton Basin Area are not available to the Western-San Bernardino Watermaster.

WEST VALLEY WATER DISTRICT

During the base period 1959-1963 West Valley Water District produced water from the Colton Basin Area within San Bernardino Valley. Using data from Volume 1, Table No. 3; Volume 2, Table No. 3; Volume 3, Table No. 3; State Water Project Deliveries by Turnout; and Table No. 2, Table No. 15 shows extractions from the Colton Basin Area within San Bernardino Valley/State Water Project water during the base period 1959-1963. It also shows deliveries for use on lands not within Western nor tributary to the Riverside Narrows. Using these data, an average annual quantity of water from the Colton Basin Area within San Bernardino Valley and delivered for use on lands not within Western nor tributary to the Riverside Narrows was determined for the base period 1959-1963.

Using data from Volume 1, Table No. 3; Volume 2, Table No. 3; Volume 3, Table No. 3; State Water Project Deliveries by Turnout; and Table No. 2, Table No. 15 also shows extractions from the Colton Basin Area within San Bernardino Valley/State Water Project water during calendar years 2008-2012. Using these data, an average annual quantity of water from the Colton Basin Area within San Bernardino Valley delivered for use on lands not within Western nor tributary to the Riverside Narrows was determined for calendar years 2008-2012.

TABLE NO. 15

DETERMINATION OF DELIVERIES FROM THE COLTON BASIN AREA
 WITHIN SAN BERNARDINO VALLEY FOR USE ON LANDS NOT
 WITHIN WESTERN NOR TRIBUTARY TO THE RIVERSIDE NARROWS
 BASED ON TOTAL SUPPLY

WEST VALLEY WATER DISTRICT

(Quantities in Acre Feet)

	1959	1960	1961	1962	1963	5-yr Ave.	2008	2009	2010	2011	2012	5-yr Ave.
San Bernardino Basin Area (SBBB) Extractions - V1T3/V1T3	13,584	12,090	13,587	11,331	11,837	12,486	13,754	12,716	7,986	7,697	8,637	10,158
SBBB Baseline Feeder supply	0	0	0	0	0	0	2,747	2,568	2,431	2,628	2,065	2,488
subtract return from WWWD Division Box	0	0	0	0	0	0	0	0	0	0	0	0
SBBB Total Supply	13,584	12,090	13,587	11,331	11,837	12,486	16,501	15,284	10,417	10,325	10,702	12,646
Colton Basin Area within San Bernardino Valley Extractions - V2T3/V2T3	3,235	4,195	4,173	3,040	2,769	3,482	2,751	3,741	5,336	4,883	4,093	4,161
Riverside Basin Area within San Bernardino County Extractions - V3T3/V3T3	1,209	1,325	1,282	1,164	975	1,191	2,269	938	0	1,073	2,085	1,273
State Water Project water	0	0	0	0	0	0	860	193	8	403	849	463
Total Extractions/Supply	18,028	17,610	19,042	15,535	15,581	17,159	22,381	20,156	15,761	16,684	17,729	18,542
San Bernardino Basin Area Percentage	75.349%	68.654%	71.353%	72.939%	75.971%	72.766%	73.728%	75.829%	66.094%	61.886%	60.364%	67.600%
Colton Basin Area within San Bernardino Valley Percentage	17.944%	23.822%	21.915%	19.569%	17.772%	20.293%	12.292%	18.560%	33.856%	29.268%	23.086%	23.400%
Riverside Basin Area within San Bernardino County Percentage	6.706%	7.524%	6.732%	7.493%	6.258%	6.941%	10.138%	4.654%	0.000%	6.431%	11.760%	6.600%
State Water Project water Percentage	0.000%	0.000%	0.000%	0.000%	0.000%	0.000%	3.843%	0.958%	0.051%	2.415%	4.789%	2.400%
Total Percentage	100.000%	100.000%	100.000%	100.000%	100.000%	100.000%	100.000%	100.000%	100.000%	100.000%	100.000%	100.000%
Total Deliveries for Use on Lands not within Western nor Tributary to the Riverside Narrows V7T2/V7T2	2,239	1,726	2,032	1,641	1,389	1,806	8,189	7,374	6,820	4,850	5,590	6,565
Prorated Deliveries for Use on Lands not within Western nor Tributary to the Riverside Narrows from Colton Basin Area within San Bernardino Valley	402	411	445	321	247	366	1,007	1,369	2,309	1,419	1,291	1,479

CITY OF RIALTO

During the base period 1959-1963 City of Rialto produced water from the Colton Basin Area within San Bernardino Valley. Using data from Volume 1, Table No. 3; Volume 2, Table No. 3; Volume 3, Table No. 3; State Water Project Deliveries by Turnout; and Table No. 2, Table No. 16 shows extractions from the Colton Basin Area within San Bernardino Valley/State Water Project water during the base period 1959-1963. It also shows deliveries for use on lands not within Western nor tributary to the Riverside Narrows. Using these data, an average annual quantity of water from the Colton Basin Area within San Bernardino Valley and delivered for use on lands not within Western nor tributary to the Riverside Narrows was determined for the base period 1959-1963.

Using data from Volume 1, Table No. 3; Volume 2, Table No. 3; Volume 3, Table No. 3; State Water Project Deliveries by Turnout; and Table No. 2, Table No. 16 also shows extractions from the Colton Basin Area/State Water Project water within San Bernardino Valley during calendar years 2008-2012. Using these data, an average annual quantity of water from the Colton Basin Area within San Bernardino Valley delivered for use on lands not within Western nor tributary to the Riverside Narrows was determined for calendar years 2008-2012.

TABLE NO. 16

DETERMINATION OF DELIVERIES FROM THE COLTON BASIN AREA
 WITHIN SAN BERNARDINO VALLEY FOR USE ON LANDS NOT
 WITHIN WESTERN NOR TRIBUTARY TO THE RIVERSIDE NARROWS
 BASED ON TOTAL SUPPLY

CITY OF RIALTO

(Quantities in Acre Feet)

	1959	1960	1961	1962	1963	5-yr Ave.	2008	2009	2010	2011	2012	5-yr Ave.
San Bernardino Basin Area (SBBA) Extractions - V/T3/V1T3 Column 2 + Column 3	1,450	794	906	1,068	1,157	1,075	6,545	5,713	5,325	3,377	3,102	4,812
SBBA Baseline Feeder supply	0	0	0	0	0	0	3,403	3,611	2,580	4,030	4,730	3,671
SBBA Total Supply	1,450	794	906	1,068	1,157	1,075	9,948	9,324	7,905	7,407	7,832	8,483
Colton Basin Area within San Bernardino Valley Extractions - V2T3/V2T3	1,147	1,243	1,874	1,873	2,139	1,655	2,352	3,219	2,782	2,206	2,771	2,666
Riverside Basin Area within San Bernardino County Extractions - V3T3/V3T3 excluding 3601680	0	0	0	0	0	0	0	0	0	0	0	0
State Water Project water	0	0	0	0	0	0	0	0	0	0	0	0
Total Extractions/Supply	2,597	2,037	2,780	2,941	3,296	2,730	12,300	12,543	10,687	9,613	10,603	11,149
San Bernardino Basin Area Percentage	55.834%	38.979%	32.590%	36.314%	35.103%	39.377%	80.878%	74.336%	73.968%	77.052%	73.866%	76.000%
Colton Basin Area within San Bernardino Valley Percentage	44.166%	61.021%	67.410%	63.686%	64.897%	60.623%	19.122%	25.664%	26.032%	22.948%	26.134%	24.000%
Riverside Basin Area within San Bernardino County Percentage	0.000%	0.000%	0.000%	0.000%	0.000%	0.000%	0.000%	0.000%	0.000%	0.000%	0.000%	0.000%
State Water Project water Percentage	0.000%	0.000%	0.000%	0.000%	0.000%	0.000%	0.000%	0.000%	0.000%	0.000%	0.000%	0.000%
Total Percentage	100.000%	100.000%	100.000%	100.000%	100.000%	100.000%	100.000%	100.000%	100.000%	100.000%	100.000%	100.000%
Total Deliveries for Use on Lands not within Western nor Tributary to the Riverside Narrows V7T3/V7T3	575	553	555	552	518	551	1,657	1,711	1,877	1,168	1,216	1,526
Prorated Deliveries for Use on Lands not within Western nor Tributary to the Riverside Narrows from Colton Basin Area within San Bernardino Valley	254	337	374	352	336	334	317	439	489	268	318	366

CHAPTER VI

INCREASED DELIVERIES FROM THE RIVERSIDE BASIN AREA WITHIN SAN BERNARDINO COUNTY FOR USE ON LANDS NOT WITHIN WESTERN NOR TRIBUTARY TO THE RIVERSIDE NARROWS, AND LOSS OF RETURN FLOW RELATED TO SUCH INCREASED DELIVERIES

In Chapter VI the increased deliveries from Riverside Basin Area within San Bernardino County for use on lands not within Western nor Tributary to the Riverside Narrows and resulting loss of return flow related to such increase deliveries from Colton Basin Area within San Bernardino Valley are determined.

The verified amounts for the base period 1959-1963 are shown in Table I of this report. The verified amounts for calendar years 2008-2012 are shown in Table J. These amounts were determined using data as detailed in the notes on the subsidiary tables.

TABLE I

DETERMINATION OF DELIVERIES FROM THE RIVERSIDE BASIN
AREA WITHIN SAN BERNARDINO COUNTY FOR USE ON LANDS NOT
WITHIN WESTERN NOR TRIBUTARY TO THE RIVERSIDE NARROWS
(1959-1963)

<u>Deliveries to</u>	<u>Source in this Volume</u>	<u>1959-63 Ave. Annual Amount</u>
<u>Lands Not Within Western nor Tributary to the Riverside Narrows</u>	<u>Chapter VI</u>	
Fontana Water Union Company	Table No. 17, Bottom Row	0
West Valley Water District	Table No. 18, Bottom Row	125
<u>City of Rialto</u>	<u>Table No. 19, Bottom Row</u>	<u>0</u>
Average Total Deliveries		125

TABLE J

DETERMINATION OF INCREASED DELIVERIES FROM THE
RIVERSIDE BASIN AREA WITHIN SAN BERNARDINO COUNTY FOR
USE ON LANDS NOT WITHIN WESTERN NOR TRIBUTARY TO THE
RIVERSIDE NARROWS, AND
LOSS OF RETURN FLOW RELATED TO SUCH INCREASED DELIVERIES

<u>Deliveries to</u>	<u>Table #</u>	<u>Row #</u>	<u>2008</u>	<u>2009</u>	<u>2010</u>	<u>2011</u>	<u>2012</u>	<u>5 year Average</u>
<u>Lands Not Within Western nor Tributary to the Riverside Narrows</u>								
Fontana Water Union Company	17	Bottom	0	0	0	0	0	0
West Valley Water District	18	Bottom	830	343	0	312	657	428
City of Rialto	19	Bottom	0	0	0	0	0	0
Total Deliveries			830	343	0	312	657	428
1959-63 Average Total Deliveries	I	Bottom	125	125	125	125	125	125
Increased Deliveries			705	218	(125)	187	532	303
Loss of Return Flow related to Increased Deliveries			254	78	(45)	67	192	109

FONTANA UNION WATER COMPANY

During the base period 1959-1963 Fontana Union Water Company did not produce water from the Riverside Basin Area within San Bernardino County. Using data from Volume 3, Table No. 3, Table No. 17 shows extractions from the Riverside Basin Area within San Bernardino County during the base period 1959-1963. It also shows deliveries for use on lands not within Western nor tributary to the Riverside Narrows. Using these data, an average annual quantity of water from the Riverside Basin Area within San Bernardino County and delivered for use on lands not within Western nor tributary to the Riverside Narrows was determined for the base period 1959-1963.

Using data from Volume 3, Table No. 3, Table No. 17 also shows extractions from the Riverside Basin Area within San Bernardino County during calendar years 2008-2012. Using these data, an average annual quantity of water from the Riverside Basin Area within San Bernardino County delivered for use on lands not within Western nor tributary to the Riverside Narrows was determined for calendar years 2008-2012.

TABLE NO. 17

DETERMINATION OF DELIVERIES FROM THE RIVERSIDE BASIN
 AREA WITHIN SAN BERNARDINO COUNTY FOR USE ON LANDS NOT
 WITHIN WESTERN NOR TRIBUTARY TO THE RIVERSIDE NARROWS

FONTANA UNION WATER COMPANY

(Quantities in Acre Feet)

	1959	1960	1961	1962	1963	5-yr Ave.	2008	2009	2010	2011	2012	5-yr Ave.
Riverside Basin Area within San Bernardino County Extractions - (1) V3T3/V3T3	0	0	0	0	0	0	0	0	0	0	0	0
(2) Wells	0	0	0	0	0	0	0	0	0	0	0	0
Total Riverside Basin Area within San Bernardino County	0	0	0	0	0	0	0	0	0	0	0	0
(3) Production	0	0	0	0	0	0	0	0	0	0	0	0
Riverside Basin Area within San Bernardino County Deliveries	0	0	0	0	0	0	0	0	0	0	0	0
(4) County Deliveries	0	0	0	0	0	0	0	0	0	0	0	0
Fontana Union Water Company service area	0	0	0	0	0	0	0	0	0	0	0	0
(5) Other	0	0	0	0	0	0	0	0	0	0	0	0
(6) Total Riverside Basin Area	0	0	0	0	0	0	0	0	0	0	0	0
Riverside Basin Area within San Bernardino County Production Delivered for Use on Lands not within Western no Tributary to the Riverside Narrows = (3) - (7) r	0	0	0	0	0	0	0	0	0	0	0	0
(8) =0 if negative	0	0	0	0	0	0	0	0	0	0	0	0

WEST VALLEY WATER DISTRICT

During the base period 1959-1963 West Valley Water District produced water from the Riverside Basin Area within San Bernardino County. Using data from Volume 1, Table No. 3; Volume 2, Table No. 3; Volume 3, Table No. 3; State Water Project Deliveries by Turnout; and Table No. 2, Table No. 18 shows extractions from the Basin Area within San Bernardino County/State Water Project water during the base period 1959-1963. It also shows deliveries for use on lands not within Western nor tributary to the Riverside Narrows. Using these data, an average annual quantity of water from the Riverside Basin Area within San Bernardino Valley and delivered for use on lands not within Western nor tributary to the Riverside Narrows was determined for the base period 1959-1963.

Using data from Volume 1, Table No. 3; Volume 2, Table No. 3; Volume 3, Table No. 3; State Water Project Deliveries by Turnout; and Table No. 2, Table No. 18 also shows extractions from the Riverside Basin Area within San Bernardino County/State Water Project water during calendar years 2008-2012. Using these data, an average annual quantity of water from the Riverside Basin Area within San Bernardino County delivered for use on lands not within Western nor tributary to the Riverside Narrows was determined for calendar years 2008-2012.

TABLE NO. 18

DETERMINATION OF DELIVERIES FROM THE RIVERSIDE BASIN
 AREA WITHIN SAN BERNARDINO COUNTY FOR USE ON LANDS NOT
 WITHIN WESTERN NOR TRIBUTARY TO THE RIVERSIDE NARROWS

BASED ON TOTAL SUPPLY

WEST VALLEY WATER DISTRICT

(Quantities in Acre Feet)

	1959	1960	1961	1962	1963	5-yr Ave.	2008	2009	2010	2011	2012	5-yr Ave.
San Bernardino Basin Area												
(SBBA) Extractions - V1T3/V1T3	13,584	12,090	13,587	11,331	11,837	12,486	13,754	12,716	7,986	7,697	8,637	10,158
SBBA Baseline Feeder supply	0	0	0	0	0	0	2,747	2,568	2,431	2,628	2,065	2,488
subtract return from WWD												
Division Box	0	0	0	0	0	0	0	0	0	0	0	0
SBBA Total Supply	13,584	12,090	13,587	11,331	11,837	12,486	16,501	15,284	10,417	10,325	10,702	12,646
Colton Basin Area within San												
Bernardino Valley Extractions -												
V2T3/V2T3	3,235	4,195	4,173	3,040	2,769	3,482	2,751	3,741	5,336	4,883	4,093	4,161
Riverside Basin Area within												
San Bernardino County												
Extractions - V3T3/V3T3	1,209	1,325	1,282	1,164	975	1,191	2,269	938	0	1,073	2,085	1,273
State Water Project water	0	0	0	0	0	0	860	193	8	403	849	463
Total Extractions/Supply	18,028	17,610	19,042	15,535	15,581	17,159	22,381	20,156	15,761	16,684	17,729	18,542
San Bernardino Basin Area												
Percentage	75.349%	68.654%	71.353%	72.939%	75.971%	72.766%	73.728%	75.829%	66.094%	61.886%	60.364%	67.600%
Colton Basin Area within San												
Bernardino Valley Percentage	17.944%	23.822%	21.915%	19.569%	17.772%	20.293%	12.292%	18.560%	33.856%	29.268%	23.086%	23.400%
Riverside Basin Area within												
San Bernardino County												
Percentage	6.706%	7.524%	6.732%	7.493%	6.258%	6.941%	10.138%	4.654%	0.000%	6.431%	11.760%	6.600%
State Water Project water												
percentage	0.000%	0.000%	0.000%	0.000%	0.000%	0.000%	3.843%	0.958%	0.051%	2.415%	4.789%	2.400%
Total Percentage	100.000%	100.000%	100.000%	100.000%	100.000%	100.000%	100.000%	100.000%	100.000%	100.000%	100.000%	100.000%
Total Deliveries for Use on												
Lands not within Western nor												
Tributary to the Riverside												
Narrows V7T2/V7T2	2,239	1,726	2,032	1,641	1,389	1,806	8,189	7,374	6,820	4,850	5,590	6,565
Prorated Deliveries for Use on												
Lands not within Western nor												
Tributary to the Riverside												
Narrows from Riverside Basin												
Area in San Bernardino County	150	130	137	123	87	125	830	343	0	312	657	428

CITY OF RIALTO

During the base period 1959-1963 City of Rialto produced water from the Riverside Basin Area within San Bernardino County. Using data from Volume 1, Table No. 3; Volume 2, Table No. 3; Volume 3, Table No. 3; State Water Project Deliveries by Turnout; and Table No. 2, Table No. 19 shows extractions from the Riverside Basin Area within San Bernardino County/State Water Project water during the base period 1959-1963. It also shows deliveries for use on lands not within Western nor tributary to the Riverside Narrows. Using these data, an average annual quantity of water from the Riverside Basin Area within San Bernardino Valley and delivered for use on lands not within Western nor tributary to the Riverside Narrows was determined for the base period 1959-1963.

Using data from Volume 1, Table No. 3; Volume 2, Table No. 3; Volume 3, Table No. 3; State Water Project Deliveries by Turnout; and Table No. 2, Table No. 19 also shows extractions from the Riverside Basin Area within San Bernardino County/State Water Project water during calendar years 2008-2012. Using these data, an average annual quantity of water from the Riverside Basin Area within San Bernardino County delivered for use on lands not within Western nor tributary to the Riverside Narrows was determined for calendar years 2008-2012.

TABLE NO. 19

DETERMINATION OF DELIVERIES FROM THE RIVERSIDE BASIN AREA WITHIN SAN BERNARDINO COUNTY FOR USE ON LANDS NOT WITHIN WESTERN NOR TRIBUTARY TO THE RIVERSIDE NARROWS BASED ON TOTAL SUPPLY

CITY OF RIALTO

(Quantities in Acre Feet)

	1959	1960	1961	1962	1963	5-yr Ave.	2008	2009	2010	2011	2012	5-yr Ave.
San Bernardino Basin Area (SBBA) Extractions - V7T3/V1T3 Column 2 + Column 3	1,450	794	906	1,068	1,157	1,075	6,545	5,713	5,325	3,377	3,102	4,812
SBBA Baseline Feeder supply	0	0	0	0	0	0	3,403	3,611	2,580	4,030	4,730	3,671
SBBA Total Supply	1,450	794	906	1,068	1,157	1,075	9,948	9,324	7,905	7,407	7,832	8,483
Colton Basin Area within San Bernardino Valley Extractions - V7T3/V2T3	1,147	1,243	1,874	1,873	2,139	1,655	2,352	3,219	2,782	2,206	2,771	2,666
Riverside Basin Area within San Bernardino County Extractions - V3T3/V3T3 excluding 3601680	0	0	0	0	0	0	0	0	0	0	0	0
State Water Project water	0	0	0	0	0	0	0	0	0	0	0	0
Total Extractions/Supply	2,597	2,037	2,780	2,941	3,296	2,730	12,300	12,543	10,687	9,613	10,603	11,149
San Bernardino Basin Area Percentage	55.834%	38.979%	32.590%	36.314%	35.103%	39.377%	80.878%	74.336%	73.968%	77.052%	73.866%	76.000%
Colton Basin Area within San Bernardino Valley Percentage	44.166%	61.021%	67.410%	63.686%	64.897%	60.623%	19.122%	25.664%	26.032%	22.948%	26.134%	24.000%
Riverside Basin Area within San Bernardino County Percentage	0.000%	0.000%	0.000%	0.000%	0.000%	0.000%	0.000%	0.000%	0.000%	0.000%	0.000%	0.000%
State Water Project water percentage	0.000%	0.000%	0.000%	0.000%	0.000%	0.000%	0.000%	0.000%	0.000%	0.000%	0.000%	0.000%
Total Percentage	100.000%	100.000%	100.000%	100.000%	100.000%	100.000%	100.000%	100.000%	100.000%	100.000%	100.000%	100.000%
Total Deliveries for Use on Lands not within Western nor Tributary to the Riverside Narrows V7T3/V7T3	575	553	555	552	518	551	1,657	1,711	1,877	1,168	1,216	1,526
Prorated Deliveries for Use on Lands not within Western nor Tributary to the Riverside Narrows from Riverside Basin Area in San Bernardino County	0	0	0	0	0	0	0	0	0	0	0	0

CHAPTER VII

The next to last sentence in Paragraph X of the Judgment as amended in the 1992 Amendment provides that:

"San Bernardino Valley shall also be obligated to provide replenishment in the Colton or Riverside Basin, as the case may be, to offset loss of return flow related to any increase over the exports therefrom within San Bernardino Valley for use in any area not within Western nor tributary to Riverside Narrows as set forth in Table C-2 of Appendix "C", such amounts being subject to correction by the Watermaster."

TABLE K

Loss of Return Flow related to increased deliveries from Colton Basin Area within San Bernardino Valley and Riverside Basin Area within San Bernardino County for use on lands not within Western nor tributary to the Riverside Narrows was determined using data from Table Nos. H and J.

TABLE K

ANNUAL ACCOUNTING FOR
 SAN BERNARDINO VALLEY MUNICIPAL WATER DISTRICT
 LOSS OF RETURN FLOW RELATED TO INCREASED DELIVERIES FROM
 COLTON BASIN AREA WITHIN SAN BERNARDINO VALLEY AND
 RIVERSIDE BASIN AREA WITHIN SAN BERNARDINO COUNTY FOR
 USE ON LANDS NOT WITHIN WESTERN NOR TRIBUTARY TO THE RIVERSIDE NARROWS

	(All Values in Acre-Feet)					
	2008	2009	2010	2011	2012	5-year Average
LOSS OF RETURN FLOW RELATED TO INCREASED DELIVERIES FROM						
Colton Basin Area within San Bernardino Valley ¹	225	399	755	355	327	412
Riverside Basin Area within San Bernardino County ²	254	78	(45)	67	192	109
Total Loss of Return Flow	479	477	710	422	519	521
ACCUMULATED						
LOSS OF RETURN FLOW ³	5,843	6,320	7,030	7,452	7,971	6,923

¹ See Table No. H

² See Table No. J

³ Accumulated values include amounts accumulated prior to current 5-year period.

CHAPTER VIII

The next to last sentence in Paragraph X of the Judgment as amended in the 1992 Amendment provides that:

“Against its replenishment obligation to offset loss of return flow related to any increase in the exports from the Colton Basin Area or Riverside Basin Area within San Bernardino Valley, San Bernardino Valley shall receive credit for that portion of direct delivered water which originated outside that Basin and which returns to the ground water of that Basin.”

In Chapter VIII the new deliveries from San Bernardino Basin Area along with supplies of State Water Project water imported for use on lands within Colton Basin Area within San Bernardino Valley and Riverside Basin Area within San Bernardino County, and resulting increased return flow related to such New Deliveries in Colton Basin Area within San Bernardino Valley and Riverside Basin Area within San Bernardino County are determined.

TABLE L

Credit for Increased Return Flow related to New Deliveries of water from outside the Basins to Colton Basin Area within San Bernardino Valley and Riverside Basin Area within San Bernardino County was determined using data from Tables F and No. 20.

TABLE L

ANNUAL ACCOUNTING FOR
 SAN BERNARDINO VALLEY MUNICIPAL WATER DISTRICT
 CREDIT FOR INCREASED RETURN FLOW RELATED TO NEW DELIVERIES OF
 WATER FROM OUTSIDE THE BASINS TO
 COLTON BASIN AREA WITHIN SAN BERNARDINO VALLEY AND
 RIVERSIDE BASIN AREA WITHIN SAN BERNARDINO COUNTY

(All Values in Acre-Feet)

	2008	2009	2010	2011	2012	5-year Average
INCREASED RETURN FLOW RELATED TO NEW DELIVERIES FROM						
San Bernardino Basin Area ¹	4,296	3,533	982	1,514	2,064	2,478
State Water Project water ²	196	44	2	103	209	111
Total Increased Return Flow	4,492	3,577	984	1,617	2,273	2,589
ACCUMULATED INCREASED RETURN FLOW ³	63,359	66,936	67,920	69,537	71,810	67,912

¹ See Table No. F

² See Table No. 20

³ Accumulated values include amounts accumulated prior to current 5-year period.

Note: In addition to the Accumulated Increased Return Flow shown above, San Bernardino Valley also replenished Colton Basin Area with 36,751 acre-feet of State Water Project water between 1982 and 1999.

TABLE NO. 20

West Valley Water District imports State Water Project water and delivers it within their service area. Table No. 20 determines the quantity of New Deliveries of State Water Project water delivered by West Valley Water District for use on lands within Colton Basin area within San Bernardino Valley and Riverside Basin Area within San Bernardino County using data from Volume 1, Table No. 3; Volume 2, Table No. 3; Volume 3, Table No. 3; State Water Project Deliveries by Turnout; and Table No. 2.

Increased return flow related to such New Deliveries is also determined.

TABLE NO. 20

DETERMINATION OF NEW DELIVERIES OF STATE WATER PROJECT
WATER TO COLTON BASIN AREA WITHIN SAN BERNARDINO VALLEY
AND RIVERSIDE BASIN AREA WITHIN SAN BERNARDINO COUNTY
BASED ON TOTAL SUPPLY, AND
INCREASED RETURN FLOW RELATED TO SUCH NEW DELIVERIES

WEST VALLEY WATER DISTRICT

(Quantities in Acre Feet)

	2008	2009	2010	2011	2012	5-yr Ave.
San Bernardino Basin Area (SBBA) Extractions - V1T3/V1T3	13,754	12,716	7,986	7,697	8,637	10,158
SBBA Baseline Feeder supply	2,747	2,568	2,431	2,628	2,065	2,488
subtract return from WVWD Division Box	0	0	0	0	0	0
SBBA Total Supply	16,501	15,284	10,417	10,325	10,702	12,646
San Bernardino Valley Extractions - V2T3/V2T3	2,751	3,741	5,336	4,883	4,093	4,161
Riverside Basin Area within San Bernardino County Extractions - V3T3/V3T3	2,269	938	0	1,073	2,085	1,273
State Water Project water	860	193	8	403	849	463
Total Extractions/Supply	22,381	20,156	15,761	16,684	17,729	18,542
San Bernardino Basin Area Percentage	73.728%	75.829%	66.094%	61.886%	60.364%	100.000%
Colton Basin Area within San Bernardino Valley Percentage	12.292%	18.560%	33.856%	29.268%	23.086%	0.000%
Riverside Basin Area within San Bernardino County Percentage	10.138%	4.654%	0.000%	6.431%	11.760%	0.000%
State Water Project water percentage	3.843%	0.958%	0.051%	2.415%	4.789%	0.000%
Total Percentage	100.000%	100.000%	100.000%	100.000%	100.000%	100.000%
Total Deliveries for Use on Lands not within Western nor Tributary to the Riverside Narrows V7T2/V7T2	8,189	7,374	6,820	4,850	5,590	6,565
Prorated Deliveries for Use on Lands not within Western nor Tributary to the Riverside Narrows from Colton Basin Area within San Bernardino Valley	315	71	3	117	268	155
Net SWP Water Delivered for use in Colton Basin Area within San Bernardino Valley and Riverside Basin Area within San Bernardino County	545	122	5	286	581	308
1959-63 Average Deliveries	0	0	0	0	0	0
New Deliveries	545	122	5	286	581	308
Increased Return Flow Related to New Deliveries	196	44	2	103	209	111

VOLUME 7-2012

SECTION V

USES OF WATER IMPORTED FROM THE STATE WATER PROJECT

CHAPTER IX

STATE WATER PROJECT WATER

The San Bernardino Valley Municipal Water District has a Contract with the State of California, Department of Water Resources, for a supply of water from the State Water Project. Deliveries began in December 1972. Deliveries of this imported water are made to many locations within and without San Bernardino Valley Municipal Water District's boundaries in accordance with provisions of the Contract. The deliveries within the District boundary include groundwater recharge and direct deliveries for use in the Colton Basin Area within San Bernardino Valley, San Bernardino Basin Area, and Yucaipa Basin.

Table No. 21 shows deliveries of imported water (State Water Project) in recharge categories by basin, and direct delivery categories showing inside San Bernardino Basin Area and outside San Bernardino Basin Area deliveries. These values are used in preparation of Table No. 17 in the Annual Report.

Table No. 22 shows deliveries of imported water inside San Bernardino Basin Area for direct deliveries, Big Bear Municipal Water District in-lieu deliveries and return flow inside San Bernardino Basin Area for direct deliveries excluding Big Bear in-lieu deliveries. The Big Bear Municipal Water District in-lieu deliveries are used in preparation of Table No. 8 in Volume 1 and Table No. 17 in the Annual Report.

TABLE NO. 21

STATE WATER PROJECT DELIVERIES FOR
SAN BERNARDINO VALLEY MUNICIPAL WATER DISTRICT
BY TYPE AND PLACE OF USE

(All Values in Acre-Feet)

Calendar Year	Total SWP Water Received	Colton Basin Area Recharge	Total San Bernardino Basin Area Recharge	SWP Water spread for WMWD	Net SBBA		Yucaipa Basin Recharge	Direct Deliveries Outside San Bernardino Basin Area	Direct Deliveries Inside San Bernardino Basin Area
					Basin Recharge for SBVMWD	Basin Recharge			
2008	36,433	0	14,266	0	14,266	1,001	12,756	8,410	
2009	35,074	0	15,081	2,459	12,622	1,952	8,581	9,460	
2010	50,570	0	18,717	0	18,717	4,603	24,871	2,379	
2011	29,390	0	18,999	0	18,999	2,558	6,661	1,172	
2012	112,450	0	24,220	0	24,220	3,055	79,336	5,839	

TABLE NO. 22

STATE WATER PROJECT DELIVERIES FOR
SAN BERNARDINO VALLEY MUNICIPAL WATER DISTRICT
SAN BERNARDINO BASIN AREA RETURN FLOW

(All Values in Acre-Feet)

Calendar Year	Direct Deliveries Inside San Bernardino Basin Area	Bear Valley In Lieu Deliveries in San Bernardino Basin Area	Net Direct Deliveries Inside San Bernardino Basin Area Excluding Bear Valley In Lieu Deliveries	Return Flow from Net Direct Deliveries Inside San Bernardino Basin Area Excluding Bear Valley In Lieu Deliveries
2008	8,410	4,634	3,776	1,359
2009	9,460	5,990	3,470	1,249
2010	2,379	2,479	0	0
2011	1,172	789	383	138
2012	5,839	4,696	1,143	411

**WESTERN - SAN BERNARDINO WATERMASTER
FOR**

WESTERN MUNICIPAL WATER DISTRICT et al.

vs.

EAST SAN BERNARDINO COUNTY WATER DISTRICT et al.

CASE NO. 78426 - COUNTY OF RIVERSIDE

VOLUME 8 - 2012

**GROUNDWATER SURFACE ELEVATIONS
OF WELLS NUMBERED 1S/4W-21Q3,
1S/4W-29H1 AND 1S/4W-29Q1 LOCATED WITHIN
THE COLTON BASIN AREA AND
RIVERSIDE BASIN AREA IN SAN BERNARDINO COUNTY
THROUGH DECEMBER 2013**

**ANNUAL ACCOUNTING
2012**

April 1, 2014

WATERMASTER

*Douglas D. Headrick
John V. Rossi*

REPORT OF WATERMASTER

Western Municipal Water District of Riverside County, et al.
Plaintiffs

vs.

East San Bernardino County Water District, et al.
Defendants

Superior Court of Riverside County

Case No. 78426

Volume 8 - 2012

GROUNDWATER SURFACE ELEVATIONS
OF WELLS NUMBERED 1S/4W-21Q3
1S/4W-29H1 AND 1S/4W-29Q1 LOCATED WITHIN
THE COLTON BASIN AREA AND
RIVERSIDE BASIN AREA IN SAN BERNARDINO COUNTY
THROUGH DECEMBER 2012

ANNUAL ACCOUNTING

April 1, 2014

WATERMASTER

Douglas D. Headrick
John V. Rossi

VOLUME 8-2012

TABLE OF CONTENTS

	<u>Page</u>
INTRODUCTION	i
<u>MAP NO. 1</u>	
SHOWING LOCATIONS OF WELLS	1
<u>FIGURE NO. 1</u>	
2013 GROUNDWATER SURFACE ELEVATIONS (JOHNSON NO. 1)	2
<u>FIGURE NO. 1A</u>	
HISTORICAL LOWEST FALL STATIC GROUNDWATER ELEVATIONS, 1936-2013, 1S/4W-21Q03S (JOHNSON NO. 1)	3
<u>FIGURE NO. 2</u>	
2013 GROUNDWATER SURFACE ELEVATIONS (FLUME NO. 2)	4
<u>FIGURE NO. 2A</u>	
HISTORICAL LOWEST FALL STATIC GROUNDWATER ELEVATIONS, 1936-2013, 1S/4W-29H01S (FLUME NO. 2)	5
<u>FIGURE NO. 3</u>	
2013 GROUNDWATER SURFACE ELEVATIONS (FLUME NO. 5)	6
<u>FIGURE NO. 3A</u>	
HISTORICAL LOWEST FALL STATIC GROUNDWATER ELEVATIONS, 1931-2013, 1S/4W-29Q01S (FLUME NO. 5)	7
<u>TABLE NO. 1</u>	
LOWEST STATIC WATER LEVEL ELEVATIONS IN WELLS NUMBERED 1S/4W-21Q03S, 1/S/4W-29H01S, & 1S/4W-29Q01S FOR YEARS 1963 THROUGH PRESENT	8
WELL MEASUREMENT RECORD, JOHNSON NO. 1, STATE WELL NUMBER 1S/4W-21Q03S, 1970 THROUGH PRESENT	11
WELL MEASUREMENT RECORD, FLUME NO. 2, STATE WELL NUMBER 1S/4W-29H01S, 1970 THROUGH PRESENT	50
WELL MEASUREMENT RECORD, FLUME NO. 5, STATE WELL NUMBER 1S/4W-29Q01S, 1970 THROUGH PRESENT	81

VOLUME 8-2012

GROUNDWATER SURFACE ELEVATIONS
OF WELLS NUMBERED 1S/4W-21Q03S,
1S/4W-29H01S AND 1S/4W-29Q01S LOCATED WITHIN
THE COLTON BASIN AREA AND
RIVERSIDE BASIN AREA IN SAN BERNARDINO COUNTY

INTRODUCTION

The settlement of the case of the Orange County Water District, Plaintiff, vs. City of Chino, et al, Defendants, being Case No. 117628 in the Superior Court of the State of California in and for the County of Orange, made necessary a settlement of the case of Western Municipal Water District of Riverside County, et al, vs. East San Bernardino County Water District, which was settled by Stipulated Judgment in Case No. 78426, entered in the Superior Court of the State of California in and for the County of Riverside, on April 17, 1969.

Paragraph VIII of the judgment entitled "Extractions from Colton Basin Area and Riverside Basin Area in San Bernardino County" in subparagraph (d) recites as follows:

VII "Extractions from the Colton Basin Area and that portion of the Riverside Basin Area within San Bernardino County, for use within San Bernardino Valley, shall not be limited. However, except for any required replenishment by Western, San Bernardino Valley shall provide the water to maintain the static water levels in the area, as determined by wells numbered 1S/4W-21Q3, 1S/4W-29H1, and 1S/4W-29Q1 at an average level no lower than that which existed in the Fall season of 1963. Such 1963 average water level is hereby determined to be 822.04 feet above sea level. In future years, the level shall be computed by averaging the lowest static water levels in each of the three wells occurring at or about the same time of the year, provided that no measurements will be used which reflect the undue influence of pumping in nearby wells, or in the three wells, or pumping from the Riverside Basin in Riverside in the three wells, or pumping from Riverside Basin in Riverside County in excess of that determined pursuant to Paragraph IX(a) hereof."

Pursuant to the foregoing, the Watermaster has compiled all available records and data pertinent to the water surface elevation in the three key wells named in the Judgment and shown on Map No. 1. These data, including elevations through December 1971, are presented in "Report of Watermaster, Volume 8" dated June, 1972.

Groundwater elevations of the key wells for calendar years 1972 through 2013 are presented in "Report of Watermaster", Volume 8-1971 through Volume 8-2012. The current report includes the detail data for calendar year 2013 along with graphical summaries of historic water level elevations.

Figures 1, 2, and 3 graphically display the specific static water elevations for each key well that were used to select the lowest elevation for calendar year 2013. Figures 1A, 2A and 3A show the lowest fall static water elevation recorded each year for each of the three wells since about 1935.

Table No. 1 presents the lowest static water level elevation for each well and the average low elevation for the three wells for calendar year 1963 and calendar years 1964-2013.

The basic data compiled in tabular form at the end of this report is based on measurements of depth to water by the City of Riverside (C of R), the United States Geological Survey (USGS), San Bernardino Valley Municipal Water District (SBVMWD), Western Municipal Water District (WMWD) and Watermaster Support Services (Watermaster).

Monthly measurements of the key wells by the USGS began in October 1972 under a cooperative agreement with SBVMWD. In July 1974, the USGS agreement was terminated. The USGS does measure Flume No. 2 as part of a different contract with SBVMWD and the data are included in the volume. This agreement was terminated in 2009.

For calendar Year 2013, using the City of Riverside and Watermaster Support Services data, the average of the lowest static level in each well has been determined to be at an elevation of 835.47 feet above mean sea level (msl).

This elevation is 13.43 feet higher than the 1963 minimum (822.04 msl) required by the Judgment. This is a decrease of 0.42 feet from the previous year.

ERRATA

Events noted during the following years:

Report Year 2012 (December 2013)

Calendar year 2013 was another dry year with the CIMIS weather station at UC Riverside reporting 5.60" of rainfall compared to the +25 year station average of 8.93" (63% of average).

The Watermaster staff had requested a one week shut down of the City of Riverside Flume Well Field, City of Colton Fogg wells and Meeks & Daley Sperry well, to create a non-pumping period to allow the water table to stabilize in order that a reasonable seasonal low measurement be taken. Shutdown was for 119 hours, between Wednesday November 27th and December 2nd. Riverside and Watermaster staff took a daily manual water level as a control for RPU data loggers.

The small decrease in the average water level, during a another dry year, is attributed to a decrease in Riverside's production of the Flume Tract in 2013.

It is expected that Colton's #30 well will be equipped and ready for operation in early 2014.

Report Year 2011 (December 2012)

Calendar year 2012 was another dry year with the CIMIS weather station at UC Riverside reporting 5.23" of rainfall compared to the +25 year station average of 9.02" (57% of average).

We have added historical water levels for the three wells. This report is now a complete record of the Watermaster work from 1970 to the present date.

The City of Riverside put a new well into service, Flume #7, in May of 2012. This +2,000 gpm well is located on the south bank of the Santa Ana River, down gradient 2,000 feet to the south west of Flume #5.

The Watermaster staff had requested a one week shut down of the City of Riverside Flume Well Field to create a non-pumping period to allow the water table to stabilize in order that a reasonable seasonal low measurement be taken.

During the planned November 2012 shutdown, due to operational considerations, the City was only able to shut down Flume #2 and #4, leaving Flume #3 and #7 still in operation.

On December 11, 2012, the Flume Well Field was shut down for a second time and RPU and Watermaster Support Services staff were able to take daily water level measurements through December 17th. A storm system passed through the watershed on December 13th, dropping 0.82" at UCR and causing a peak storm flow at the USGS E Street gage of +1,500 cfs early that morning. The data logger in Flume 5 showed a noticeable shift in the curve on December 13 which we interpreted as storm water recharge. As a result of this, December 12th was picked for the seasonal non-pumping period low.

Based on the December shutdown, the CY 2012 average water level was 835.89', this is 13.85' above the Base Period average of 822.04'. Volume 8 has not reported an average elevation this low since 1968.

The Watermaster staff has been informed that the City of Colton is planning on equipping their recently completed Well #30, which is approximately 900 feet north-west of Flume #2, roughly parallel to the local groundwater flow path. There are no plans to equip Well #31 which is adjacent to #30. E-mail exchanges with Colton staff note that Colton understands the need for non-pumping water levels and they are amenable for future cooperation on this topic.

Report Year 2010 (January 2012)

Rainfall for 2010 was slightly above average at the CIMIS (California Irrigation Management Information System) station located at University of California at Riverside.

The hydrographs show a slight decrease of 0.44' in the lowest static water levels for the year. Johnson #1 decreased 2.53' while Flume #2 gained 1.75' and Flume #5 showed a gain of 2.01'.

Lows for the Flume wells were picked for November 3, 2010. The Flume wells field had been shut down 4 days before to allow for groundwater level recovery and to give a reasonable seasonal low. Johnson #1 date was picked in the same time frame and with field observation note that Colton #23 was off on December 1, 2010.

On October 16, 2009 a new locking lid and sounder box was installed on Flume 5. Two new reference points have been established.

914.622' from 2" measuring pipe inside lid

913.488' from 2" pipe on top of sounding box

Two new Colton "Fogg Street" wells have not been equipped as of this date. Meeks & Daley #36 has been destroyed and a new well "Sperry" has been drilled but not equipped.

The Flume Well Field was shut down for approximately 25 hours between October 8 and 9, 2009, to observe the Flume Well Field's pumping recovery. Water level measurements were recorded during this shut-down period. The non-pumping inferred seasonal low for the year occurred on October 9, 2009, for all key wells.

Report Year 2010 (December 2011)

City of Riverside shut down the Flume Well Field for three days at the end of October, which was enough time for the basin to recover and allow the Watermaster Staff to determine a reasonable seasonal low for the year, without pumping interference, as called for in the Judgment.

The new Meeks & Daley Sperry well is now equipped. The wells pumping status is checked by the Watermaster during its measurements of Johnson #1 to document possible pumping interference.

The City of Riverside is using the Flume Wells for part of the State of California CASGEM water level program. The CASGEM Program specifically calls for elevation data to be based on the NAVD 1988 vertical datum. Using this datum, Riverside re-surveyed the City's wells in the area.

The survey data used in the Watermaster Judgment for the Key Wells elevations is assumed to be based the NGVD 1929 datum.

This change of base datums has yielded an increase in regional elevations of about 2.5' higher than the earlier surveys.

Because the Judgment calls out the specific elevation of 822.04' above sea level (Judgment page 18), staff has opted to stay with the older survey elevations. This will mean that if the water surface elevation for these three key wells is used in other report, the MSL elevations will differ.

The new NAVD 88 survey data from the City of Riverside was received on August 17, 2011 reported,

Johnson #1 957.14' (presently 954.5', +2.64')
RP inside well lid, next to large center opening

Flume #2 935.088' (presently 932.45', +2.638')
RP top of sounding tube

Flume #5 916.04' (presently 913.45', +2.59')
RP top of sounding box

Because of recent construction activities by the City of Riverside at the Key Well sites, the San Bernardino Valley MWD field staff was unable to take their independent water level measurements during the year due to changes in locks. The Watermaster staff has requested that Riverside provide access to Valley District staff.

Regarding water levels taken at Johnson #1. The Watermaster's manual measurements are normally taken early to mid morning at which time staff physically visits to both Colton #23 and M&D Sperry to determine if these wells are pumping and effecting Johnsons water levels.

Water level data taken by the City of Riverside are picked from data logger information that is recorded at noon each day. Staff assumes that the occasional difference in closely spaced visits is due to nearby pumping by of one these two wells. It is understood that Colton #23 operates "on demand".

Report Year 2009 (March 2010)

The City of Riverside re-surveyed the reference point elevations for all key wells on December 30, 2008, and the reference point elevations in the data tables and charts were updated to reflect these changes. In addition, the City of Riverside demolished the concrete structure above the casing at Flume No.5, removed the old angled measuring tube, and added a new steel sounding box and tube configuration to the well casing. City of Riverside staff estimated a new reference point elevation for Flume No.5 (913.53 feet above mean sea level) on October 16, 2009, pending re-survey.

Report Year 2007:

In 2007, the City of Riverside reworked Flume Nos. 2, 3, 4, and 6 wells and re-activated Flume No. 1. These wells were re-equipped to supply the City's new John W. North Micro-Filtration plant located on the south side of the Santa Ana River.

As part of a construction project, all three Key Wells were resurveyed and data loggers installed. The following table shows the old measuring point (MP) elevations and the new MP elevations (measured in feet above mean sea level):

<u>Well</u>	<u>Old MP</u>	<u>New MP</u>
Johnson No. 1	960.00	959.37
Flume No.2	932.18	932.45
Flume No.5	916.53	913.22

Starting with the calendar year 2008 reading, the new MP elevations are being used.

Report Year 2008: (March 2009)

In 2008, the City of Colton drilled two new production wells just west of the Flume Tract, along Fogg Street.

It is anticipated that our ability to pick seasonal low water levels in which "...no measurements will be used which reflect the undue influence of pumping in nearby wells, ..." will be greatly impaired with the re-working of the Flume Tract and the addition of the Colton Fogg Street wells (Colton Wells #30 and #31).

Report Years 2006 to 2008:

A lack of significant rainfall during 2006, 2007, and 2008 lowered the average static water level measurement in 2007 and 2008.

Report Year 2004:

Heavy precipitation that occurred during the 2004/2005 rainy season appears to have recharged local groundwater basins and significantly raised the average static water level measurement during calendar year 2005.

Report Year 1999:

The process of selecting lows was made more difficult in 1999 and 2000 due to extensive pumping interferences; and in 2001 and 2002, difficulties were encountered because the High Groundwater Mitigation Program was in effect.

Report Year 1998:

The El Nino storm events raised the water levels in all three key wells during 1998.

Report Year 1996:

During the second week of April 1996, the Santa Ana Watershed Project Authority's (SAWPA) Rapid Infiltration/Extraction (RIX) Project came on-line and dry season flow below the E Street gage ceased.

Report Year 1991:

In 1991 the City of Colton started operation of a new well, Colton "Well #23." This well is approximately 100 yards to the northeast of Johnson No. 1. Pumping of Colton #23 is affecting the annual low water level readings.

Report Year 1990:

In 1990, the stream relocated approximately 150 east of the Flume No. 5 well, and the data from this well is beginning to better reflect the regional groundwater conditions.

Report Year 1982:





The City of Riverside established a new measurement point for the Flume No. 5 well in May **1982**. The elevation of this new reference point has been established as 916.53 feet above mean sea level. Therefore, there are now three reference points available for use on the Flume 5 well. The well record tables included in this report indicate which reference point was used for each measurement since 1976.

Report Year 1979:

Since **1979**, flow in the Santa Ana River caused channel erosion of about 8 feet in the vicinity of the Flume No. 5 well, and the river was flowing immediately adjacent to the well most of the year. However, as a result of the channel erosion, the elevation of the water table since 1981 is about 10 feet less than in prior years when a similar saturated condition existed.

MAP NO. 1 VOLUME 8

Legend

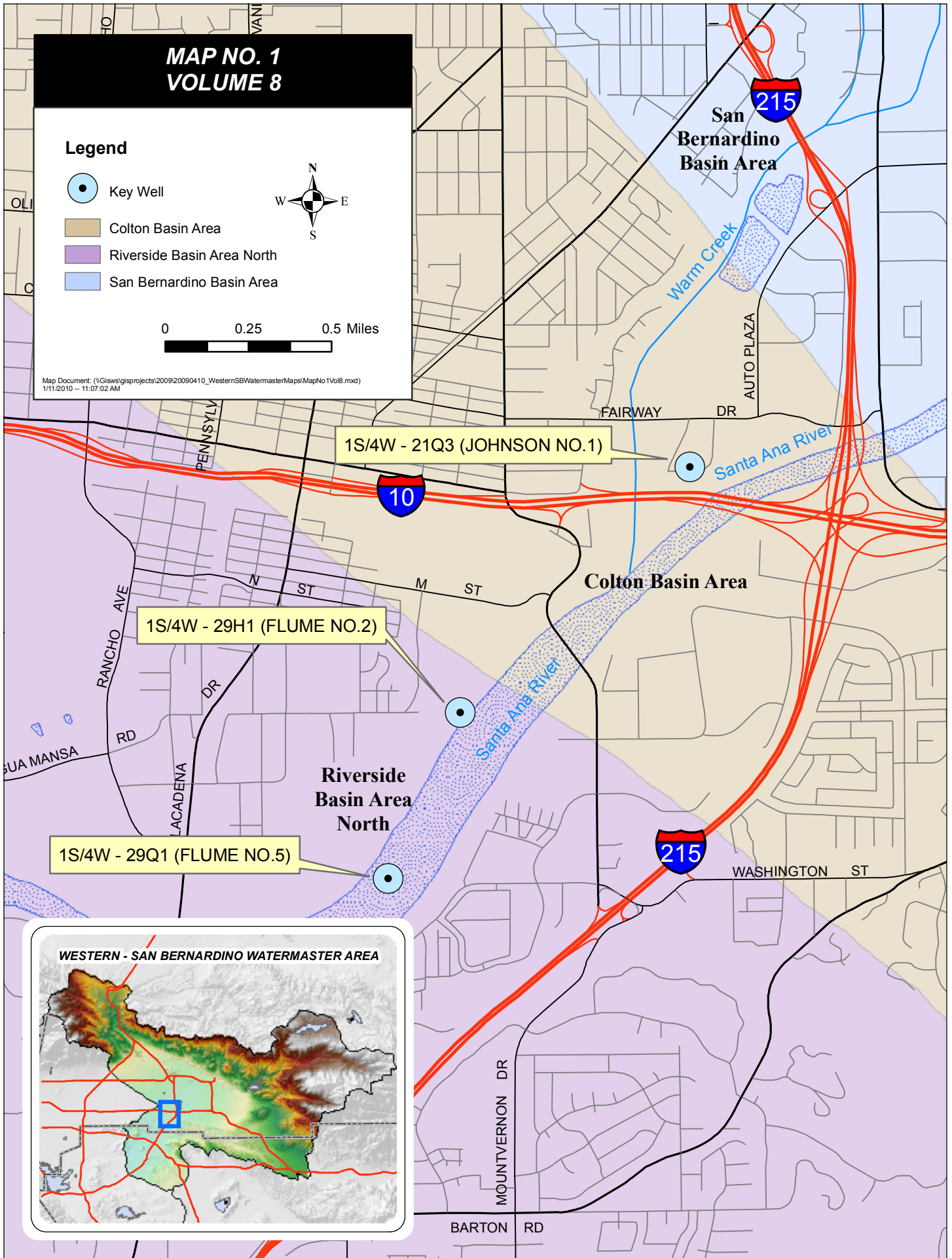
-  Key Well
-  Colton Basin Area
-  Riverside Basin Area North
-  San Bernardino Basin Area



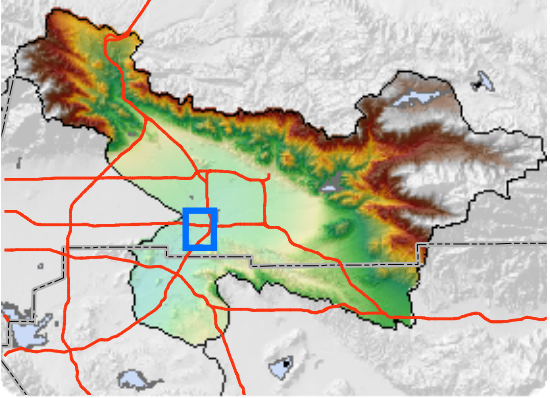
0 0.25 0.5 Miles



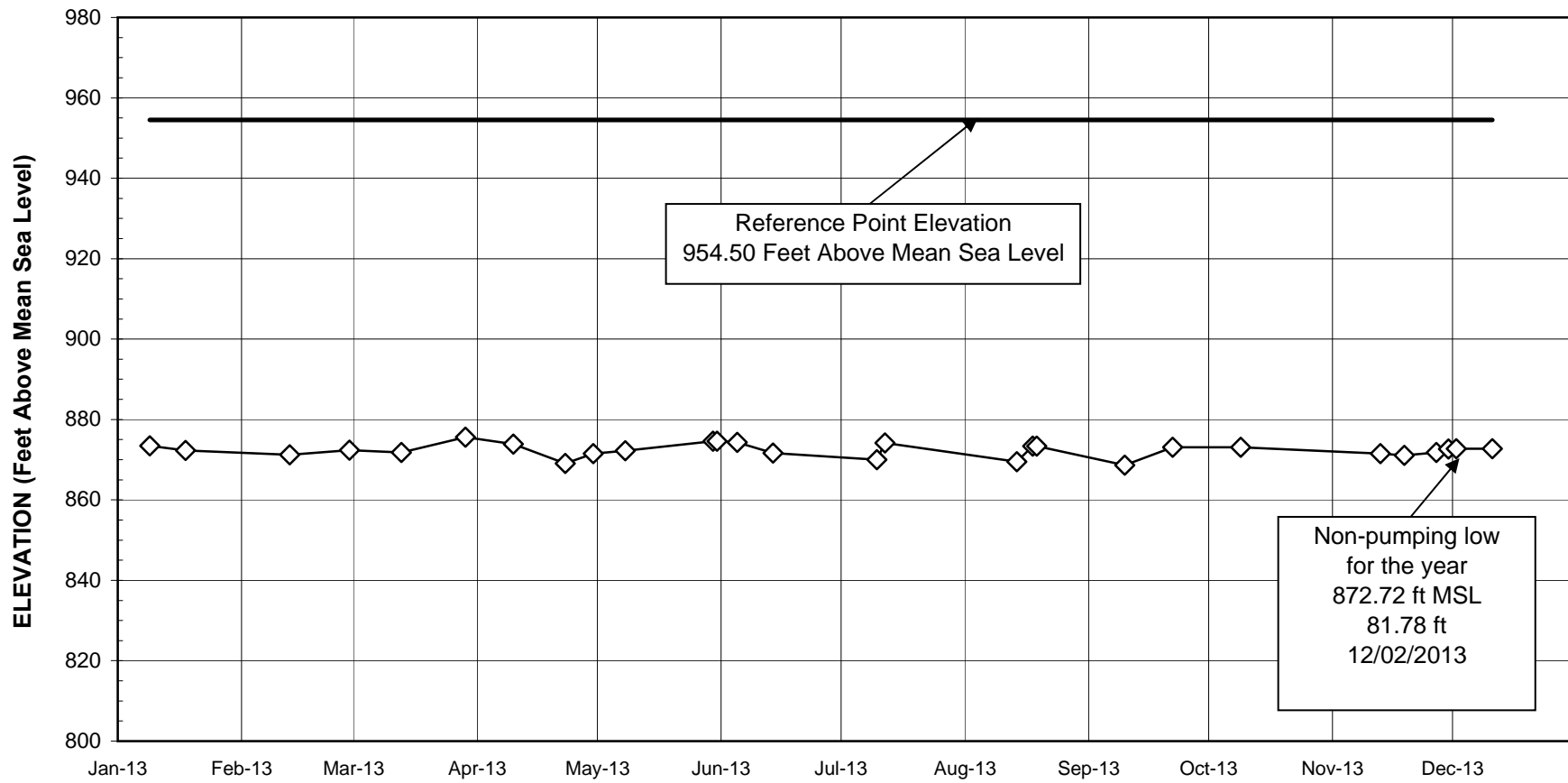
Map Document: (\\Gis\gis\projects\2009\20090410_WesternSWWatermaster\Map\MapNo1Vol8.mxd)
1/11/2010 -- 11:07:02 AM



WESTERN - SAN BERNARDINO WATERMASTER AREA

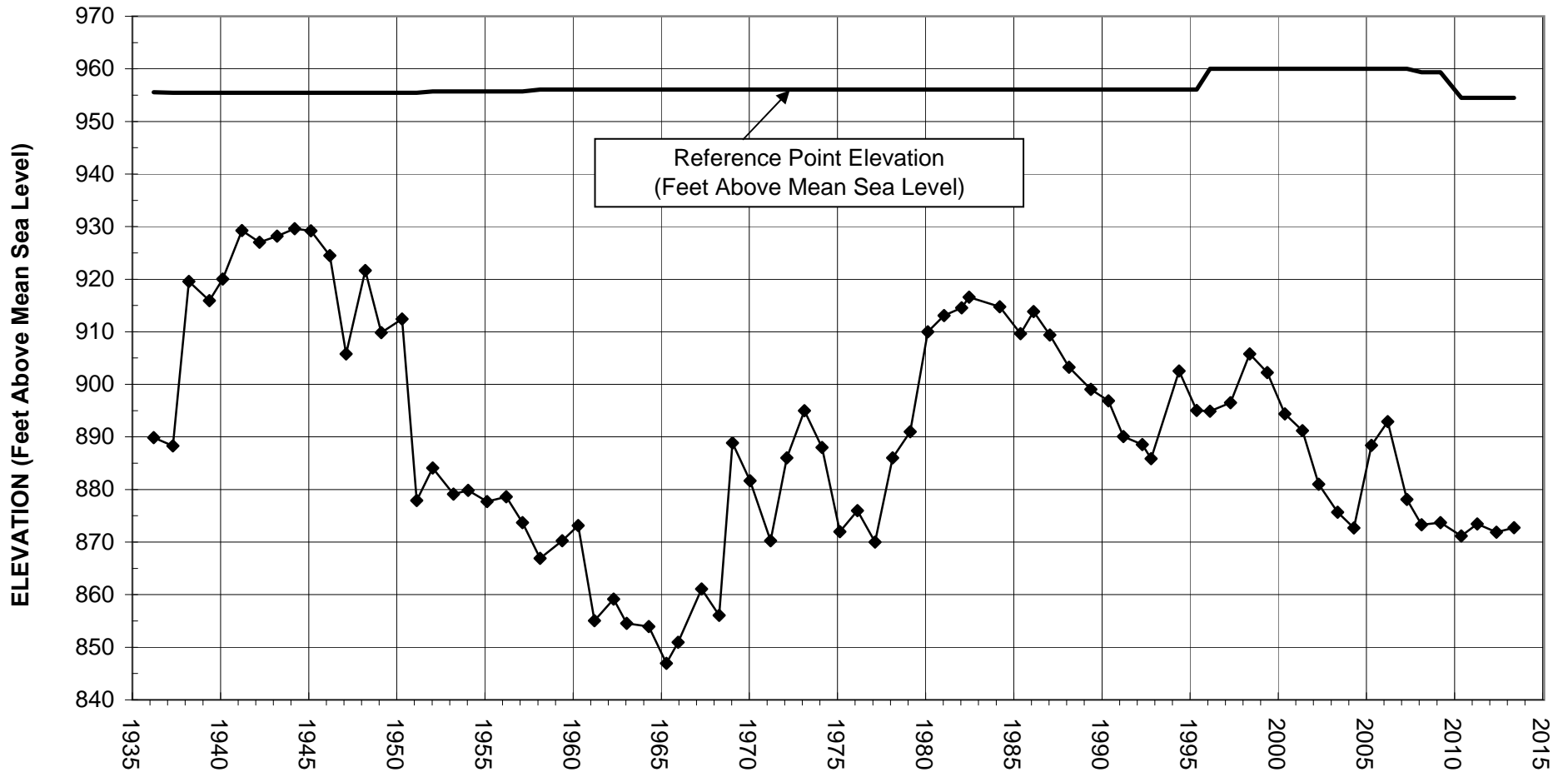


**FIGURE 1
GROUNDWATER SURFACE ELEVATIONS
1S/4W-21Q03S
JOHNSON NO. 1 WELL
2013**

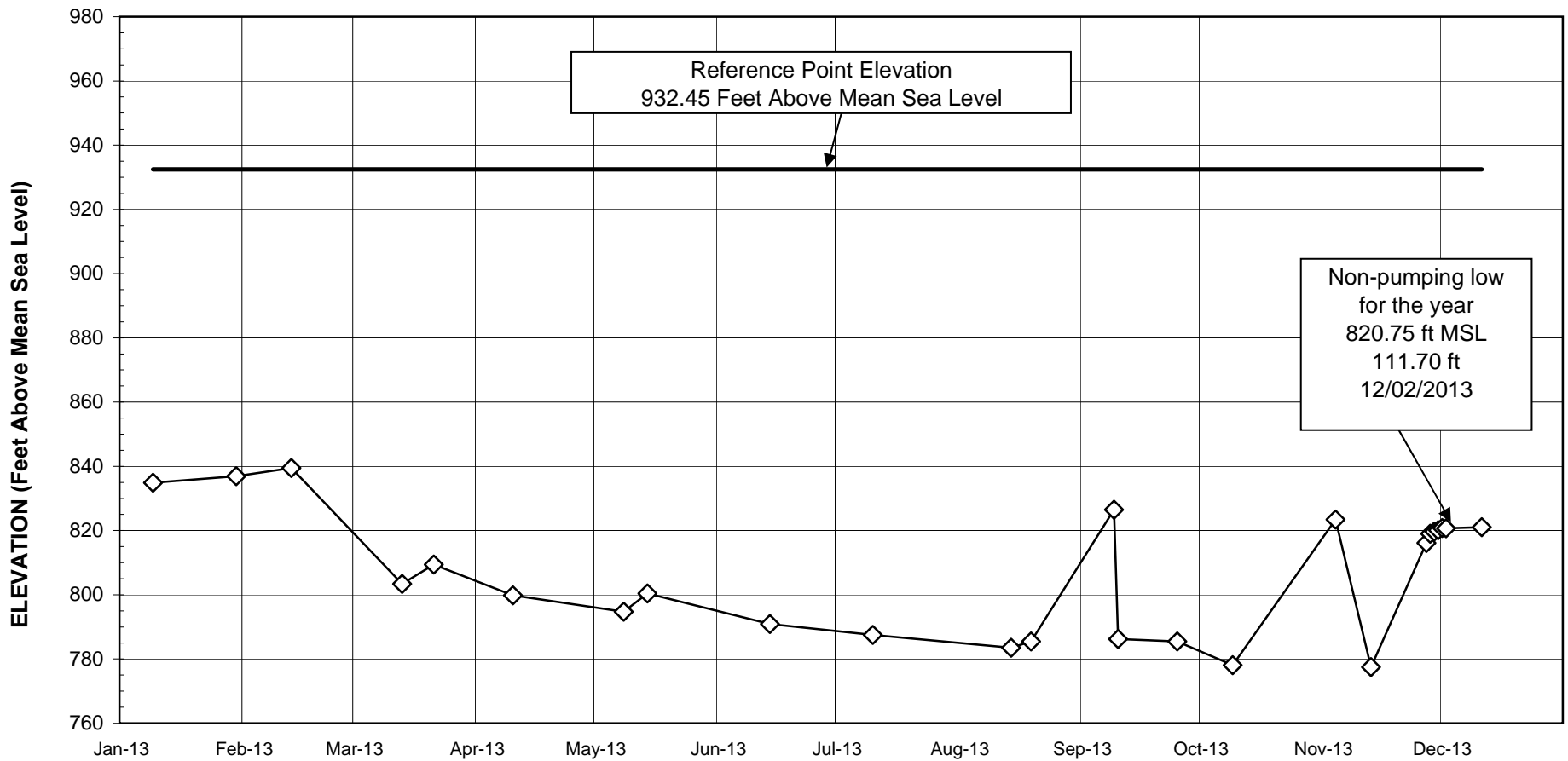


State Well Number: 1S4W21Q03S
Recordation Number: 3601480
Basin: Colton
Owner: City of Riverside

FIGURE 1A
HISTORICAL LOWEST FALL STATIC
GROUNDWATER ELEVATIONS
JOHNSON NO. 1 WELL

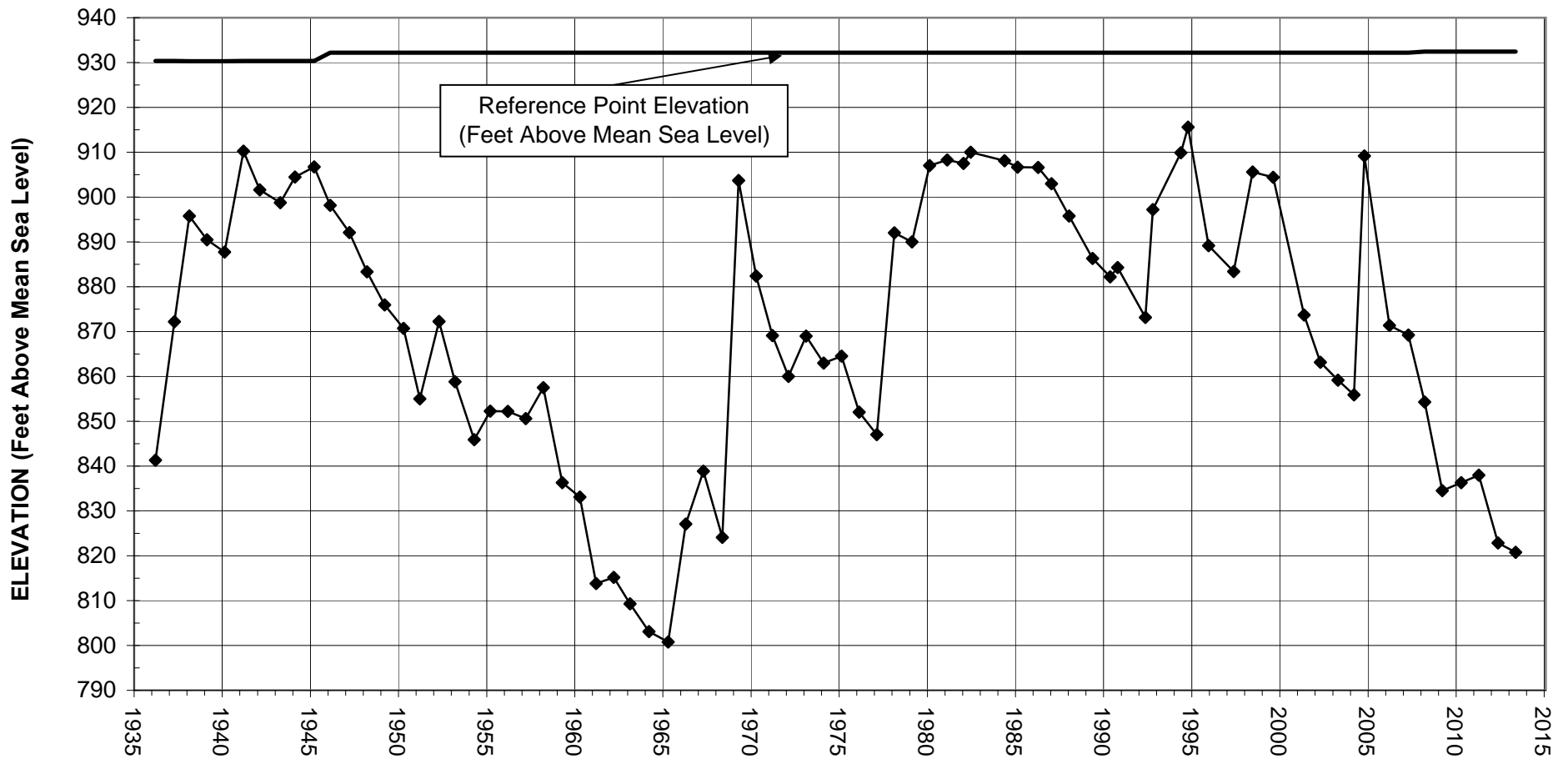


**FIGURE 2
GROUNDWATER SURFACE ELEVATIONS
1S/4W-29H01S
FLUME NO. 2 WELL
2013**

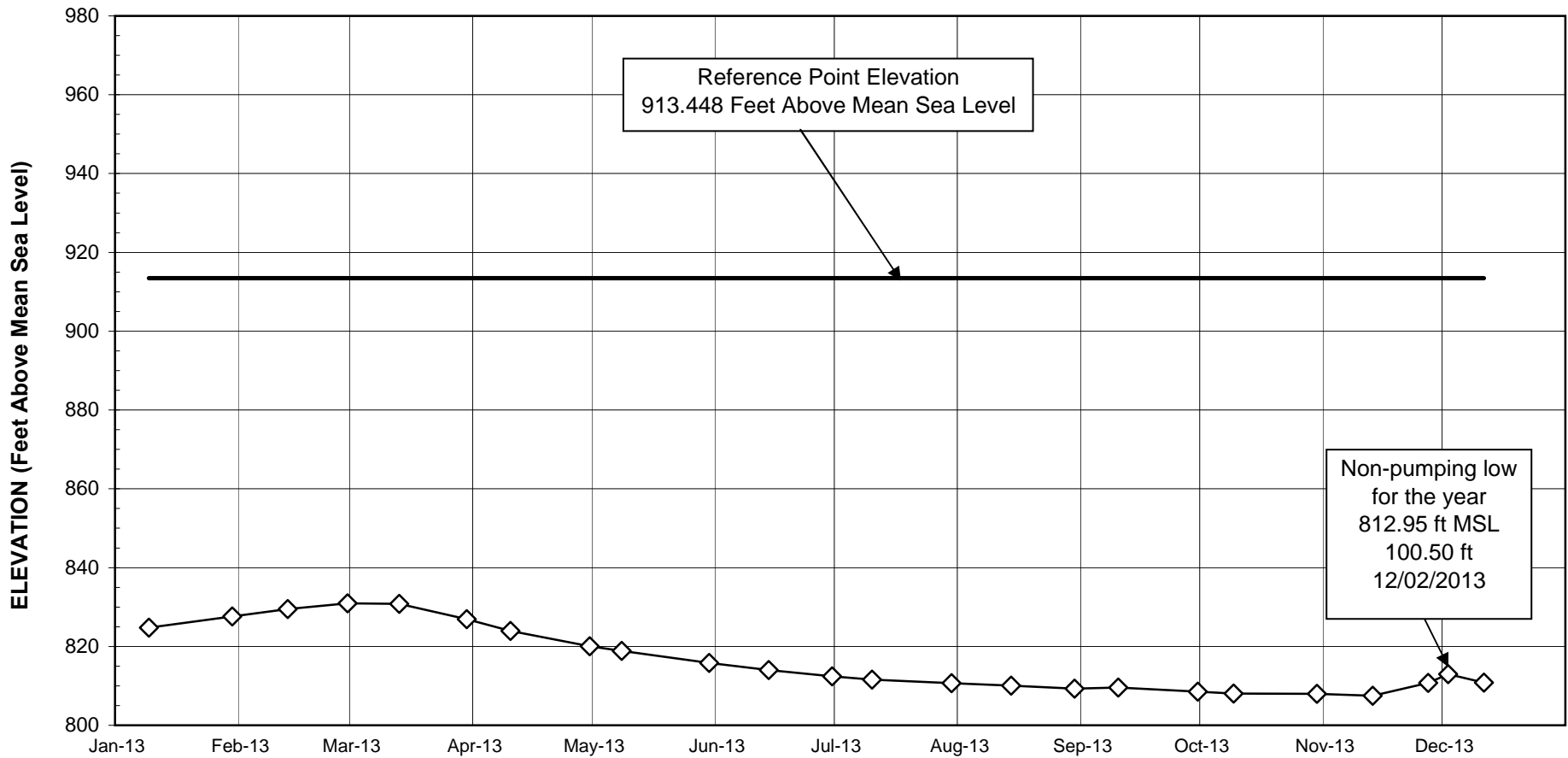


State Well Number: 1S4W29H01S
Recordation Number: 3601484
Basin: Riverside North
Owner: City of Riverside

FIGURE 2A
HISTORICAL LOWEST FALL STATIC
GROUNDWATER ELEVATIONS
FLUME NO. 2 WELL



**FIGURE 3
GROUNDWATER SURFACE ELEVATIONS
1S/4W-29Q01S
FLUME NO. 5 WELL
2013**



State Well Number: 1S4W29Q01S
Recordation Number: 3601487
Basin: Riverside North
Owner: City of Riverside

FIGURE 3A
HISTORICAL LOW FALL STATIC
GROUNDWATER ELEVATIONS
FLUME NO. 5 WELL

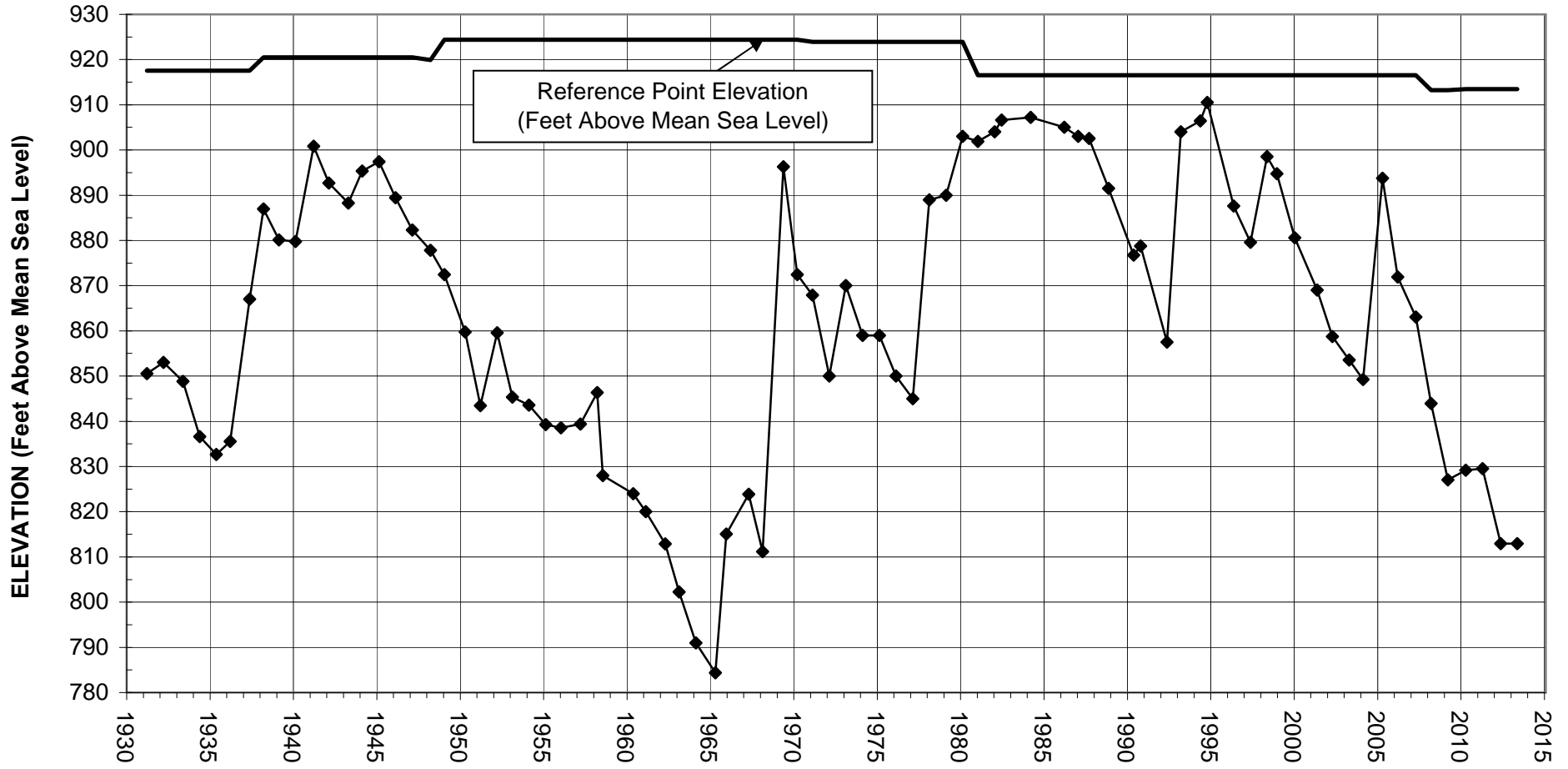


TABLE NO. 1

LOWEST STATIC WATER LEVEL ELEVATION IN WELLS NUMBERED
1S/4W-21Q03S, 1S/4W-29H01S & 1S/4W-29Q01S
FOR YEARS 1963 AND 1981 THROUGH PRESENT

STATIC WATER LEVEL ELEVATION

Calendar Year	Well #1S/4W-21Q03S Johnson No. 1		Well #1S/4W-29H01S Flume No. 2		Well #1S/4W-29Q01S Flume No. 5		Total of three wells	Average three wells	Feet above Minimum Requirement
	Lowest Static W.S.Elev.	Date Recorded	Lowest Static W.S.Elev.	Date Recorded	Lowest Static W.S.Elev.	Date Recorded			
1963	854.56	Aug. 01	809.28	Sept. 20	802.27	Sept. 19	2466.11	*822.04	
1964	853.96	Nov. 06	803.08	Oct. 23	790.97	Sep. 18	2448.01	816.00	-6.04
1965	846.96	Nov. 12	800.78	Nov. 12	784.37	Nov. 05	2432.11	810.70	-11.34
1966	850.96	Jul. 29	826.28	Nov. 04	815.07	Jul. 02	2492.31	830.77	8.73
1967	862.56	Sep. 15	838.88	Nov. 10	823.87	Nov. 10	2525.31	841.77	19.73
1968	856.06	Nov. 01	824.08	Dec. 13	811.17	Sep. 13	2491.31	830.44	8.40
1969	888.86	Aug. 25	903.68	Nov. 24	896.27	Dec. 08	2688.81	896.27	74.23
1970	881.66	Aug. 17	882.38	Nov. 02	872.47	Oct. 12	2636.51	878.84	56.80
1971	870.26	Oct. 04	869.08	Oct. 04	867.92	Sep. 27	2607.26	869.09	47.05
1972	888.46	Nov. 20	860.58	Nov. 27	850.52	Nov. 20	2599.56	866.52	44.48
1973	895.26	Nov. 16	869.48	Nov. 20	869.42	Oct. 30	2634.16	878.05	56.01
1974	887.05	Oct. 24	863.78	Oct. 31	858.82	Oct. 22	2609.65	869.88	47.84
1975	871.36	Nov. 12	865.48	Nov. 19	858.48	Nov. 12	2595.32	865.11	43.07
1976	875.88	Jul. 15	853.08	Jun. 30	849.63	Jul. 15	2578.59	859.53	37.49
1977	869.66	Dec. 06	847.18	Dec. 27	845.45	Dec. 27	2562.29	854.10	32.06
1978	886.06	Nov. 21	891.63	Nov. 15	888.05	Nov. 06	2665.74	888.58	66.54
1979	892.06	Oct. 11	890.48	Oct. 11	889.25	Oct. 16	2671.79	890.60	68.56
1980	911.93	Nov. 25	907.48	Nov. 11	902.72	Nov. 03	2722.13	907.38	85.34
1981	913.06	Aug. 13	908.28	Sep. 02	901.92	Aug. 18	2723.26	907.75	85.71
1982	914.56	Aug. 06	907.48	Aug. 25	904.03	Aug. 25	2726.07	908.69	86.65
1983	916.56	Jan. 04	909.98	Jan. 18	906.63	Jan. 18	2733.17	911.06	89.02
1984	914.76	Oct. 02	908.08	Dec. 01	907.23	Oct. 02	2730.07	910.02	87.98
1985	909.66	Dec. 01	906.68	Sep. 01	907.23	**	2723.57	907.86	85.82

* Minimum Average Water Level as provided for in the Section VIII (d) of the Judgment.

** Unable to measure during 1985, assume same low as previous year.

TABLE NO. 1

Page 2 of 3

LOWEST STATIC WATER LEVEL ELEVATION IN WELLS NUMBERED
1S/4W-21Q03S, 1S/4W-29H01S & 1S/4W-29Q01S
FOR YEARS 1963 AND 1986 THROUGH PRESENT

STATIC WATER LEVEL ELEVATION

Calendar Year	Well #1S/4W-21Q03S Johnson No. 1		Well #1S/4W-29H01S Flume No. 2		Well #1S/4W-29Q01S Flume No. 5		Total of three wells	Average three wells	Feet above Minimum Requirement
	Lowest Static W.S.Elev.	Date Recorded	Lowest Static W.S.Elev.	Date Recorded	Lowest Static W.S.Elev.	Date Recorded			
1963	854.56	Aug. 1	809.28	Sept. 20	802.27	Sept. 19	2466.11	*822.04	
1986	913.86	Sept. 23	906.58	Nov. 19	905.03	Oct. 24	2725.47	908.49	86.45
1987	909.36	Aug. 16	902.98	Aug. 25	903.03	Aug. 20	2715.37	905.12	83.08
1988	903.26	Sept. 01	895.78	Aug. 01	902.53	Apr. 14	2701.57	900.52	78.48
1989	899.06	Dec. 01	886.28	Dec. 31	891.53	Jun. 12	2676.87	892.29	70.25
1990	896.86	Dec. 01	882.18	Dec. 02	876.73	Dec. 12	2655.77	885.26	63.22
1991	890.06	Oct. 10	884.28	May 31	878.78	May. 31	2653.12	884.37	62.33
1992	888.56	Nov. 27	873.18	Dec. 15	857.53	Dec. 15	2619.27	873.09	51.05
1993	885.86	May 18	897.18	May 04	904.03	Oct. 26	2687.07	895.69	73.65
1994	902.56	Dec. 06	909.88	Dec. 06	906.43	Dec. 06	2718.87	906.29	84.25
1995	895.06	Dec. 05	915.58	May 24	910.53	May 24	2721.17	907.06	85.02
1996	894.90	Sept. 30	889.18	July 19	887.63	Dec. 17	2671.71	890.57	68.53
1997	896.50	Nov. 18	883.38	Dec. 16	879.58	Dec. 29	2659.46	886.49	64.45
1998	905.80	Dec. 18	905.58	Jan 9 '99	898.53	Dec. 18	2709.91	903.30	81.26
1999	902.23	Dec. 28	905.58	Jan 9 '99	894.73	Jul. 27	2702.54	900.85	78.81
2000	899.20	Sept. 18	904.38	Mar. 21	880.61	Sept. 14	2684.19	894.73	72.69
2001	891.20	Dec. 04	873.68	Dec. 04	869.03	Dec. 04	2633.91	877.97	55.93
2002	881.00	Nov. 12	863.18	Nov. 18	858.73	Nov. 22	2602.91	867.64	45.60
2003	875.68	Dec. 08	859.18	Nov. 19	853.53	Nov. 14	2588.39	862.80	40.76
2004	872.70	Nov. 15	855.88	Oct. 25	849.23	Sept. 20	2577.81	859.27	37.23
2005	888.40	Nov. 28	909.18	May 27	893.73	Nov. 05	2691.31	897.10	75.06

* Minimum Average Water Level as provided for in the Section VIII (d) of the Judgment.

** Unable to measure during 1985, assume same low as previous year.

TABLE NO. 1

LOWEST STATIC WATER LEVEL ELEVATION IN WELLS NUMBERED
1S/4W-21Q03S, 1S/4W-29H01S & 1S/4W-29Q01S
FOR YEARS 1963 THROUGH PRESENT

STATIC WATER LEVEL ELEVATION

Calendar Year	Well #1S/4W-21Q03S Johnson No. 1		Well #1S/4W-29H01S Flume No. 2		Well #1S/4W-29Q01S Flume No. 5		Total of three wells	Average three wells	Feet above Minimum Requirement
	Lowest Static W.S.Elev.	Date Recorded	Lowest Static W.S.Elev.	Date Recorded	Lowest Static W.S.Elev.	Date Recorded			
1963	854.56	Aug. 1	809.28	Sept. 20	802.27	Sept. 19	2,466.11	*822.04	
2006	892.90	10/09/06	871.38	10/04/06	871.93	10/04/06	2,636.21	878.74	56.70
2007	878.11	11/28/07	869.25	11/28/07	863.03	11/19/07	2,610.39	870.13	48.09
2008	873.29	09/08/08	854.27	10/01/08	843.96	10/01/08	2,571.52	857.17	35.13
2009	873.71	10/09/09	834.54	10/09/09	827.05	10/09/09	2,535.30	845.10	23.06
2010	871.18	12/01/10	836.29	11/03/10	829.15	11/03/10	2,536.62	845.54	23.50
2011	873.46	11/02/11	837.96	11/02/11	829.51	11/02/11	2,540.93	846.98	24.94
2012	871.90	12/12/12	822.83	12/12/12	812.95	12/12/12	2,507.68	835.89	13.85
2013	872.72	12/02/13	820.75	12/02/13	812.95	12/02/13	2,506.42	835.47	13.43
2014									
2015									
2016									
2017									
2018									
2019									
2020									
2021									
2022									
2023									
2024									
2025									
2026									
2027									
2028									
2029									
2030									

* Minimum Average Water Level as provided for in the Section VIII (d) of the Judgment.

Western San Bernardino Watermaster Well Measurement Record for

Johnson #1

State Well Number 1S/4W21Q03S

Water Level Records
1970-2013

Basin: Colton-Rialto

Reference Point Elevation: 956.06

Reference Point Elevation #2, top of MP: 960

After January 2008, Reference Point Elevation #3, top of MP: 959.37

After October 2009, Reference Point Elevation #4, top of MP inside lid, 954.5



Photo's clockwise from top left - Johnson No. 1 Pump house 1977, Johnson No. 1 Pump and MP 1977, Johnson No.1 lid open May 2010, Johnson No.1 close-up May 2010.

**Western San Bernardino Watermaster
Well Measurement Record for**

Johnson #1

State Well Number 1S/4W21Q03S

Basin: Colton-Rialto

Reference Point Elevation: 956.06

Date	Obtained from	Ref. Pt. to Water	Water Surface Elevation	Remarks
1970				
05/11/70		63.90	892.16	Static
05/25/70		47.50	908.56	Static
06/01/70		120.70	835.36	Pumping
06/15/70		71.60	884.46	Static
06/22/71		130.00	826.06	Pumping
07/06/70		133.80	822.26	Pumping
07/13/70		133.10	822.96	Pumping
07/20/70		133.50	822.56	Pumping
07/27/70		133.80	822.26	Pumping
08/03/70		136.40	819.66	Pumping
08/17/70		74.40	881.66	Static (low)
08/24/70		72.70	883.36	Static
09/14/70		57.80	898.26	Static
09/21/70		126.40	829.66	Pumping
10/05/70		124.10	831.96	Pumping
10/12/70		72.60	883.46	Static
11/02/70		134.30	821.76	Pumping
11/09/70		57.30	898.76	Static
11/16/70		57.10	898.96	Static
11/23/70		57.00	899.06	Static
12/28/70		53.40	902.66	Static
1971				
01/04/71		53.10	902.96	Static
01/11/71		53.60	902.46	Static
01/18/71		52.30	903.76	Static
01/25/71		53.00	903.06	Static
02/01/71		51.50	904.56	Static
04/12/71		65.50	890.56	Static
04/19/71		68.10	887.96	Static
05/10/71		65.80	890.26	Static
05/17/71		131.70	824.36	Pumping
05/24/71		75.50	880.56	Static
06/21/71		64.00	892.06	Static
06/28/71		76.00	880.06	Static
07/06/71		127.20	828.86	Pumping

**Western San Bernardino Watermaster
Well Measurement Record for**

Johnson #1

State Well Number 1S/4W21Q03S

Basin: Colton-Rialto

Reference Point Elevation: 956.06

Date	Obtained from	Ref. Pt. to Water	Water Surface Elevation	Remarks
07/12/71		127.50	828.56	Pumping
07/20/71		137.90	818.16	Pumping
07/26/71		79.30	876.76	Static
08/09/71		81.60	874.46	Static
08/16/71		82.10	873.96	Static
08/23/71		121.70	834.36	Pumping
09/16/71		85.20	870.86	Static
09/14/71		131.60	824.46	Pumping
09/20/71		139.10	816.96	Pumping
09/27/71		82.40	873.66	Static
09/30/71		85.20	870.86	Static
10/04/71		85.80	870.26	Static (low)
10/11/71		139.20	816.86	Pumping
10/18/71		85.00	871.06	Pumping
11/01/71		78.40	877.66	Pumping
11/09/71	City of Riverside	79.90	876.16	Static
11/15/71	City of Riverside	78.50	877.56	Static
11/22/71	City of Riverside	78.10	877.96	Static
12/01/71	City of Riverside	119.60	836.46	Static
12/06/71	City of Riverside	77.80	878.26	Static
12/13/71	City of Riverside	77.50	878.56	Static
12/20/71	City of Riverside	77.30	878.76	Static
12/27/71	City of Riverside	65.10	890.96	Static
1972				
01/03/72	City of Riverside	63.40	892.66	Static
01/10/72	City of Riverside	60.40	895.66	Static
01/07/72	City of Riverside	58.90	897.16	Static
01/19/72	City of Riverside	113.70	842.36	Pumping
01/24/72	City of Riverside	61.40	894.66	Static
02/01/72	City of Riverside	58.50	897.56	Static
02/07/72	City of Riverside	59.20	896.86	Static
02/14/72	City of Riverside	124.00	832.06	Pumping
02/21/72	City of Riverside	128.50	827.56	Pumping
02/28/72	City of Riverside	127.50	828.56	Pumping
03/06/72	City of Riverside	62.00	894.06	Static
03/13/72	City of Riverside	60.10	895.96	Static

**Western San Bernardino Watermaster
Well Measurement Record for**

Johnson #1

State Well Number 1S/4W21Q03S

Basin: Colton-Rialto

Reference Point Elevation: 956.06

Date	Obtained from	Ref. Pt. to Water	Water Surface Elevation	Remarks
03/20/72	City of Riverside	133.50	822.56	Pumping
03/27/72	City of Riverside	61.70	894.36	Static
04/01/72	City of Riverside	59.80	896.26	Static
04/10/72	City of Riverside	59.70	896.36	Static
04/17/72	City of Riverside	132.40	823.66	Pumping
04/24/72	City of Riverside	132.90	823.16	Pumping
05/01/72	City of Riverside	27.80	928.26	Static(Looks like Johnso
05/08/72	City of Riverside	66.50	889.56	Static
05/15/72	City of Riverside	135.00	821.06	Pumping
05/22/72	City of Riverside	80.00	876.06	Static
05/29/72	City of Riverside	81.20	874.86	Static
06/01/72	City of Riverside	131.90	824.16	Pumping
06/05/72	City of Riverside	132.10	823.96	Pumping
06/12/72	City of Riverside	68.20	887.86	Static
06/19/72	City of Riverside	79.80	876.26	Static
06/26/72	City of Riverside	132.60	823.46	Pumping
07/01/72	City of Riverside	135.10	820.96	Pumping
07/10/72	City of Riverside	131.40	824.66	Pumping
07/17/72	City of Riverside	140.80	815.26	Pumping
07/24/72	City of Riverside	139.90	816.16	Pumping
07/31/72	City of Riverside	140.20	815.86	Pumping
08/26/72	City of Riverside	140.80	815.26	Pumping
09/01/72	City of Riverside	139.20	816.86	Pumping
09/11/72	City of Riverside	86.00	870.06	Static
09/18/72	City of Riverside	70.00	886.06	Static
09/25/72	City of Riverside	68.80	887.26	Static
10/16/72	City of Riverside	68.10	887.96	Static
10/24/72	City of Riverside	67.80	888.26	Static
10/30/72	City of Riverside	67.60	888.46	Static
11/06/72	City of Riverside	67.50	888.56	Static
11/09/72	USGS	64.69	891.37	
11/14/72	City of Riverside	67.20	888.86	Static
11/20/72	City of Riverside	67.60	888.46	Static (low)
11/27/72	City of Riverside	67.20	888.86	Static
11/28/72	USGS	63.75	892.31	
12/04/72	City of Riverside	67.40	888.66	Static
12/18/72	City of Riverside	61.60	894.46	Static

**Western San Bernardino Watermaster
Well Measurement Record for**

Johnson #1

State Well Number 1S/4W21Q03S

Basin: Colton-Rialto

Reference Point Elevation: 956.06

Date	Obtained from	Ref. Pt. to Water	Water Surface Elevation	Remarks
12/26/72	City of Riverside	61.90	894.16	Static
12/27/72	USGS	62.30	893.76	Static
1973				
01/02/73	City of Riverside	63.30	892.76	Static
01/08/73	City of Riverside	63.10	892.96	Static
01/22/73	City of Riverside	63.50	892.56	Static
01/29/73	City of Riverside	62.50	893.56	Static
02/05/73	City of Riverside	63.70	892.36	Static
02/20/73	City of Riverside	63.50	892.56	Static
02/26/73	City of Riverside	63.00	893.06	Static
03/05/73	City of Riverside	63.40	892.66	Static
03/12/73	City of Riverside	63.60	892.46	Static
03/21/73	City of Riverside	59.20	896.86	Static
04/01/73	City of Riverside	58.20	897.86	Static
04/16/73	City of Riverside	57.60	898.46	Static
04/23/73	City of Riverside	57.90	898.16	Static
05/08/73	City of Riverside	58.20	897.86	Static
05/27/73	City of Riverside	61.00	895.06	Static
05/30/73	USGS	59.99	896.07	Static
06/11/73	City of Riverside	61.10	894.96	Static
06/18/73	City of Riverside	62.00	894.06	Static
06/26/73	City of Riverside	61.30	894.76	Static
07/01/73	City of Riverside	61.50	894.56	Static
07/03/73	USGS	58.08	897.98	Static
07/09/73	City of Riverside	58.80	897.26	Static
07/16/73	City of Riverside	58.60	897.46	Static
07/23/73	City of Riverside	58.70	897.36	Static
07/25/73	USGS	57.41	898.65	Static
08/06/73	City of Riverside	57.70	898.36	Static
08/13/73	City of Riverside	57.60	898.46	Static
08/20/73	City of Riverside	57.50	898.56	Static
08/28/73	USGS	57.84	898.22	Static
09/01/73	City of Riverside	58.70	897.36	Static
09/10/73	City of Riverside	58.40	897.66	Static
09/16/73	City of Riverside	58.30	897.76	Static
10/01/73	City of Riverside	57.90	898.16	Static

**Western San Bernardino Watermaster
Well Measurement Record for**

Johnson #1

State Well Number 1S/4W21Q03S

Basin: Colton-Rialto

Reference Point Elevation: 956.06

Date	Obtained from	Ref. Pt. to Water	Water Surface Elevation	Remarks
10/01/73	USGS	58.64	897.42	Static
10/08/73	City of Riverside	58.20	897.86	Static
10/16/73	City of Riverside	59.40	896.66	Static
10/23/73	City of Riverside	59.60	896.46	Static
10/30/73	City of Riverside	59.50	896.56	Static
10/30/73	USGS	59.67	896.39	Static
11/06/73	City of Riverside	60.50	895.56	Static
10/13/73	City of Riverside	59.80	896.26	Static
11/16/73	USGS	60.80	895.26	Static (low)
11/20/73	City of Riverside	60.20	895.86	Static
11/27/73	City of Riverside	60.50	895.56	Static
12/01/73	City of Riverside	60.10	895.96	Static
12/04/73	City of Riverside	60.10	895.96	Static
12/05/73	USGS	60.01	896.05	Static
12/11/73	City of Riverside	60.10	895.96	Static
12/18/73	City of Riverside	60.00	896.06	Static
12/26/73	City of Riverside	59.80	896.26	Static
1974				
01/01/74	City of Riverside	59.20	896.86	Static
01/01/74	USGS	59.37	896.69	Static
01/08/74	City of Riverside	59.40	896.66	Static
01/08/74	USGS	58.98	897.08	Static
01/15/74	City of Riverside	59.60	896.46	Static
01/16/74	USGS	59.20	896.86	Static
01/22/74	City of Riverside	58.60	897.46	Static
01/29/74	City of Riverside	58.80	897.26	Static
02/01/74	City of Riverside	58.30	897.76	Static
02/05/74	City of Riverside	58.40	897.66	Static
02/06/74	USGS	57.91	898.15	Static
02/12/74	City of Riverside	57.40	898.66	Static
02/26/74	City of Riverside	72.00	884.06	Static Vaughn Well Pumpin
03/05/74	City of Riverside	60.50	895.56	Static
03/12/74	City of Riverside	60.40	895.66	Static
03/12/74	USGS	60.50	895.56	Static
03/19/74	City of Riverside	58.20	897.86	Static
03/26/74	City of Riverside	58.20	897.86	Static

**Western San Bernardino Watermaster
Well Measurement Record for**

Johnson #1

State Well Number 1S/4W21Q03S

Basin: Colton-Rialto

Reference Point Elevation: 956.06

Date	Obtained from	Ref. Pt. to Water	Water Surface Elevation	Remarks
04/02/74	City of Riverside	125.30	830.76	Pumping
04/04/74	USGS	-	-	Pumping
04/09/74	City of Riverside	124.40	831.66	Pumping
04/17/74	City of Riverside	62.40	893.66	Static
04/23/74	City of Riverside	60.30	895.76	Static
04/30/74	City of Riverside	60.90	895.16	Static
05/07/74	City of Riverside	76.30	879.76	Static Vaughn Well Pumpin
05/14/74	City of Riverside	61.30	894.76	Static
05/21/74	City of Riverside	71.60	884.46	Static Vaughn Well Pumpin
05/28/74	City of Riverside	61.50	894.56	Static
05/31/74	USGS	60.50	895.56	Static
06/05/74	City of Riverside	67.50	888.56	Static Vaughn Well Pumpin
06/11/74	City of Riverside	65.60	890.46	Static
06/19/74	City of Riverside	66.40	889.66	Static
06/25/74	City of Riverside	65.40	890.66	Static
06/27/74	USGS	61.20	894.86	Static
07/09/74	City of Riverside	125.10	830.96	Pumping
07/16/74	SBVMWD	66.40	889.66	Static
07/17/74	City of Riverside	66.40	889.66	Static
07/24/74	City of Riverside	120.30	835.76	Pumping
07/25/74	SBVMWD	126.90	829.16	Pumping
07/29/74	SBVMWD	125.10	830.96	Pumping
07/30/74	City of Riverside	125.40	830.66	Pumping
08/09/74	City of Riverside	127.40	828.66	Pumping
08/13/74	City of Riverside	69.20	886.86	Static
08/20/74	City of Riverside	68.40	887.66	Static
08/22/74	SBVMWD	68.14	887.92	Static
08/27/74	City of Riverside	126.70	829.36	Pumping
09/01/74	City of Riverside	126.50	829.56	Pumping
09/03/74	City of Riverside	127.60	828.46	Pumping
09/10/74	City of Riverside	69.70	886.36	Static
09/12/74	SBVMWD	69.80	886.26	Static
09/24/74	City of Riverside	67.60	888.46	Static
09/26/74	SBVMWD	66.84	889.22	Static
10/01/74	City of Riverside	68.80	887.26	Static
10/08/74	City of Riverside	66.60	889.46	Static
10/16/74	City of Riverside	67.40	888.66	Static

**Western San Bernardino Watermaster
Well Measurement Record for**

Johnson #1

State Well Number 1S/4W21Q03S

Basin: Colton-Rialto

Reference Point Elevation: 956.06

Date	Obtained from	Ref. Pt. to Water	Water Surface Elevation	Remarks
10/22/74	City of Riverside	68.00	888.06	Static
10/24/74	SBVMWD	69.01	887.05	Static (low)
10/31/74	City of Riverside	65.80	890.26	Static
11/05/74	City of Riverside	65.70	890.36	Static
11/12/74	City of Riverside	69.30	886.76	Static
11/15/74	SBVMWD	62.60	893.46	Static
11/20/74	City of Riverside	78.50	877.56	Static Pumping Nearby
11/22/74	SBVMWD	78.59	877.47	Static
11/26/74	City of Riverside	79.30	876.76	Static
12/01/74	City of Riverside	79.60	876.46	Static
12/03/74	City of Riverside	79.50	876.56	Static
12/10/74	City of Riverside	67.70	888.36	Static
12/17/74	City of Riverside	66.10	889.96	Static
12/24/74	City of Riverside	65.70	890.36	Static
12/30/74	City of Riverside	64.00	892.06	Static
1975				
01/07/75	City of Riverside	63.40	892.66	Static
01/14/75	City of Riverside	64.50	891.56	Static
01/21/75	City of Riverside	138.00	818.06	Pumping
01/28/75	City of Riverside	138.40	817.66	Pumping
02/03/75	City of Riverside	138.70	817.36	Pumping
02/11/75	City of Riverside	51.50	904.56	Static
02/18/75	City of Riverside	68.80	887.26	Static
02/27/75	City of Riverside	66.20	889.86	Static
02/27/75	SBVMWD	66.20	889.86	Static
03/11/75	City of Riverside	65.60	890.46	Static
03/12/75	SBVMWD	71.29	884.77	Static
03/18/75	City of Riverside	66.00	890.06	Static
03/24/75	SBVMWD	65.20	890.86	Static
03/25/75	City of Riverside	65.80	890.26	Static
04/01/75	SBVMWD	66.00	890.06	Static
04/01/75	City of Riverside	66.00	890.06	Static
04/08/75	City of Riverside	117.10	838.96	Pumping
04/09/75	SBVMWD	70.54	885.52	Static
04/16/75	City of Riverside	64.60	891.46	Static
04/23/75	City of Riverside	63.70	892.36	Static

**Western San Bernardino Watermaster
Well Measurement Record for**

Johnson #1

State Well Number 1S/4W21Q03S

Basin: Colton-Rialto

Reference Point Elevation: 956.06

Date	Obtained from	Ref. Pt. to Water	Water Surface Elevation	Remarks
04/30/75	City of Riverside	64.10	891.96	Static
04/30/75	SBVMWD	64.10	891.96	Static
05/06/75	City of Riverside	80.40	875.66	Pumping Nearby
05/13/75	City of Riverside	147.80	808.26	Pumping
05/15/75	SBVMWD	68.23	887.83	Static
05/22/75	City of Riverside	81.40	874.66	Pumping Nearby
05/27/75	City of Riverside	82.00	874.06	Pumping Nearby
05/27/75	City of Riverside	82.00	874.06	Pumping Nearby
06/03/75	City of Riverside	83.20	872.86	Pumping Nearby
06/10/75	City of Riverside	83.00	873.06	Pumping Nearby
06/13/75	SBVMWD	70.03	886.03	Static
06/17/75	City of Riverside	84.20	871.86	Pumping Nearby
06/24/75	City of Riverside	84.70	871.36	Pumping Nearby
06/25/75	City of Riverside	84.70	871.36	Pumping Nearby
07/01/75	SBVMWD	84.80	871.26	Pumping Nearby
07/01/75	City of Riverside	84.80	871.26	Pumping Nearby
07/09/75	City of Riverside	86.10	869.96	Pumping Nearby
07/10/75	SBVMWD	69.41	886.65	Static
07/15/75	City of Riverside	78.50	877.56	Pumping Nearby
07/22/75	City of Riverside	145.60	810.46	Pumping
07/29/75	City of Riverside	146.80	809.26	Pumping
07/29/75	SBVMWD	146.80	809.26	Pumping
08/03/75	SBVMWD	147.60	808.46	Pumping
08/04/75	City of Riverside	147.60	808.46	Pumping
08/10/75	City of Riverside	147.90	808.16	Pumping
08/14/75	SBVMWD	68.71	887.35	Static
08/17/75	City of Riverside	148.10	807.96	Pumping
08/27/75	SBVMWD	149.10	806.96	Pumping
09/01/75	City of Riverside	149.10	806.96	Pumping
09/10/75	City of Riverside	152.10	803.96	Pumping
09/12/75	SBVMWD	63.22	892.84	Static
09/16/75	City of Riverside	153.50	802.56	Pumping
09/23/75	City of Riverside	157.60	798.46	Pumping
09/30/75	City of Riverside	157.80	798.26	Pumping
10/01/75	SBVMWD	157.60	798.46	Pumping
10/01/75	City of Riverside	157.60	798.46	Pumping
10/07/75	City of Riverside	158.00	798.06	Pumping

**Western San Bernardino Watermaster
Well Measurement Record for**

Johnson #1

State Well Number 1S/4W21Q03S

Basin: Colton-Rialto

Reference Point Elevation: 956.06

Date	Obtained from	Ref. Pt. to Water	Water Surface Elevation	Remarks
10/10/75	SBVMWD	62.27	893.79	Static
10/15/75	City of Riverside	154.40	801.66	Pumping
10/21/75	City of Riverside	152.80	803.26	Pumping
10/28/75	City of Riverside	153.00	803.06	Pumping
11/04/75	SBVMWD	153.20	802.86	Pumping
11/04/75	City of Riverside	153.20	802.86	Pumping
11/12/75	City of Riverside	84.60	871.46	Static
11/12/75	SBVMWD	84.70	871.36	Static (low)
11/15/75	City of Riverside	84.00	872.06	Static
11/28/75	City of Riverside	83.40	872.66	Static
12/02/75	SBVMWD	79.33	876.73	Static
12/02/75	City of Riverside	79.40	876.66	Static
12/09/75	City of Riverside	78.40	877.66	Static
12/10/75	SBVMWD	78.44	877.62	Static
12/23/75	City of Riverside	79.80	876.26	Static
12/30/75	City of Riverside	76.30	879.76	Static
1976				
01/01/76	SBVMWD	76.30	879.76	Static
01/07/76	City of Riverside	76.10	879.96	Static
01/13/76		77.60	878.46	Static
01/15/76	SBVMWD	72.11	883.95	Static
01/20/76	City of Riverside	78.10	877.96	Static
01/27/76	City of Riverside	78.10	877.96	Static
02/04/76	City of Riverside	76.60	879.46	Static
02/11/76	City of Riverside	75.60	880.46	Static
02/12/76	SBVMWD	75.75	880.31	Static
02/17/76	City of Riverside	74.60	881.46	Static
02/24/76	City of Riverside	74.80	881.26	Static
03/02/76	City of Riverside	71.30	884.76	Static
03/09/76	City of Riverside	73.70	882.36	Static
03/12/76	SBVMWD	73.26	882.8	Static
03/17/76	City of Riverside	74.50	881.56	Static
03/23/76	City of Riverside	72.90	883.16	Static
04/01/76	City of Riverside	74.10	881.96	Static
04/06/76	City of Riverside	74.20	881.86	Static
04/13/76	City of Riverside	75.20	880.86	Static

**Western San Bernardino Watermaster
Well Measurement Record for**

Johnson #1

State Well Number 1S/4W21Q03S

Basin: Colton-Rialto

Reference Point Elevation: 956.06

Date	Obtained from	Ref. Pt. to Water	Water Surface Elevation	Remarks
04/15/76	SBVMWD	76.23	879.83	Static
04/21/76	City of Riverside	76.20	879.86	Static
04/27/76	City of Riverside	76.00	880.06	Static
05/04/76	City of Riverside	65.70	890.36	Static
05/11/76	City of Riverside	73.00	883.06	Static
05/12/76	SBVMWD	79.87	876.19	Static
05/18/76	City of Riverside	74.60	881.46	Static
05/26/76	City of Riverside	76.10	879.96	Static
06/01/76	City of Riverside	77.30	878.76	Static
06/09/76	City of Riverside	77.00	879.06	Static
06/11/76	SBVMWD	77.23	878.83	Static
06/15/76	City of Riverside	75.80	880.26	Static
06/22/76	City of Riverside	77.20	878.86	Static
06/30/76	City of Riverside	77.90	878.16	Static
07/13/76	City of Riverside	78.20	877.86	Static
07/15/76	SBVMWD	80.18	875.88	Static (low)
07/27/76	City of Riverside	81.40	874.66	Pumping Nearby
08/01/76	City of Riverside	81.40	874.66	Pumping Nearby
08/10/76	City of Riverside	82.50	873.56	Pumping Nearby
08/13/76	SBVMWD	79.42	876.64	Static
08/17/76	City of Riverside	83.60	872.46	Pumping Nearby
08/24/76	City of Riverside	83.20	872.86	Pumping Nearby
08/31/76	City of Riverside	84.40	871.66	Pumping Nearby
09/08/76	City of Riverside	83.90	872.16	Pumping Nearby
09/10/76	SBVMWD	81.22	874.84	Static
09/14/76	City of Riverside	80.00	876.06	Static
09/21/76	City of Riverside	78.40	877.66	Static
09/28/76	City of Riverside	78.80	877.26	Static
10/06/76	City of Riverside	158.90	797.16	Well Pumping
10/12/76	City of Riverside	155.10	800.96	Well Pumping
10/13/76	SBVMWD	78.63	877.43	Static
10/19/76	City of Riverside	155.20	800.86	Well Pumping
10/26/76	City of Riverside	158.40	797.66	Well Pumping
11/01/76	City of Riverside	160.30	795.76	Well Pumping
11/10/76	City of Riverside	159.80	796.26	Well Pumping
11/16/76	City of Riverside	80.10	875.96	Static
11/17/76	SBVMWD	92.44	863.62	Pumping Nearby

**Western San Bernardino Watermaster
Well Measurement Record for**

Johnson #1

State Well Number 1S/4W21Q03S

Basin: Colton-Rialto

Reference Point Elevation: 956.06

Date	Obtained from	Ref. Pt. to Water	Water Surface Elevation	Remarks
11/23/76	City of Riverside	95.00	861.06	Pumping Nearby
12/01/76	City of Riverside	156.00	800.06	Well Pumping
12/07/76	City of Riverside	156.80	799.26	Well Pumping
12/14/76	City of Riverside	156.10	799.96	Well Pumping
12/16/76	SBVMWD	88.15	867.91	Static
12/21/76	City of Riverside	86.40	869.66	Static
 1977				
01/01/77	City of Riverside	85.30	870.76	Static
01/04/77	City of Riverside	85.40	870.66	Static
01/12/77	City of Riverside	82.30	873.76	Static
01/17/77	SBVMWD	82.20	873.86	Static
01/18/77	City of Riverside	81.60	874.46	Static
01/25/77	City of Riverside	81.10	874.96	Static
02/01/77	City of Riverside	80.20	875.86	Static
02/08/77	City of Riverside	80.60	875.46	Static
02/10/77	SBVMWD	81.90	874.16	Static
02/15/77	City of Riverside	81.60	874.46	Static
02/22/77	City of Riverside	82.50	873.56	Static
03/01/77	City of Riverside	78.90	877.16	Static
03/08/77	City of Riverside	78.80	877.26	Static
03/10/77	SBVMWD	81.62	874.44	Static
03/15/77	City of Riverside	79.60	876.46	Static
03/22/77	City of Riverside	80.10	875.96	Static
03/29/77	City of Riverside	79.80	876.26	Static
04/01/77	City of Riverside	79.10	876.96	Static
04/05/77	City of Riverside	78.80	877.26	Static
04/12/77	City of Riverside	80.00	876.06	Static
04/13/77	SBVMWD	82.79	873.27	Static
04/19/77	City of Riverside	79.80	876.26	Static
04/26/77	City of Riverside	80.20	875.86	Static
05/01/77	City of Riverside	79.80	876.26	Static
05/04/77	City of Riverside	80.40	875.66	Static
05/11/77	SBVMWD	81.34	874.72	Static
05/12/77	City of Riverside	81.20	874.86	Static
05/17/77	City of Riverside	79.20	876.86	Static
05/24/77	City of Riverside	78.00	878.06	Static

**Western San Bernardino Watermaster
Well Measurement Record for**

Johnson #1

State Well Number 1S/4W21Q03S

Basin: Colton-Rialto

Reference Point Elevation: 956.06

Date	Obtained from	Ref. Pt. to Water	Water Surface Elevation	Remarks
06/02/77	City of Riverside	79.80	876.26	Static
06/07/77	City of Riverside	80.00	876.06	Static
06/08/77	SBVMWD	82.10	873.96	Static
06/14/77	City of Riverside	80.00	876.06	Static
06/21/77	City of Riverside	79.90	876.16	Static
06/28/77	City of Riverside	77.80	878.26	Static
07/05/77	City of Riverside	77.90	878.16	Static
07/07/77	SBVMWD	83.32	872.74	Static
07/12/77	City of Riverside	156.00	800.06	Well Pumping
07/19/77	City of Riverside	156.70	799.36	Well Pumping
07/26/77	City of Riverside	160.60	795.46	Well Pumping
08/01/77	City of Riverside	158.20	797.86	Well Pumping
08/02/77	City of Riverside	158.40	797.66	Well Pumping
08/08/77	City of Riverside	159.20	796.86	Well Pumping
08/09/77	WMWD	89.40	866.66	Static #36 on
08/16/77	City of Riverside	90.00	866.06	Static Meeks on
08/22/77	WMWD	85.90	870.16	Static
08/23/77	City of Riverside	85.60	870.46	Static
08/25/77	SBVMWD	84.67	871.39	Static
08/31/77	City of Riverside	85.60	870.46	Static
09/01/77	City of Riverside	85.60	870.46	Static
09/05/77	City of Riverside	86.40	869.66	Static
09/06/77	WMWD	86.40	869.66	Static
09/13/77	City of Riverside	85.90	870.16	Static
09/16/77	WMWD	86.00	870.06	Static
09/20/77	City of Riverside	85.70	870.36	Static
09/21/77	SBVMWD	86.72	869.34	Static
09/27/77	City of Riverside	85.70	870.36	Static
10/01/77	City of Riverside	85.70	870.36	Static
10/03/77	WMWD	86.00	870.06	Static
10/05/77	City of Riverside	87.40	868.66	Static
10/11/77	City of Riverside	84.80	871.26	Static
10/11/77	SBVMWD	86.17	869.89	Static
10/20/77	City of Riverside	85.70	870.36	Static
10/25/77	City of Riverside	86.50	869.56	Static
11/02/77	City of Riverside	86.00	870.06	Static
11/08/77	City of Riverside	86.40	869.66	Static

**Western San Bernardino Watermaster
Well Measurement Record for**

Johnson #1

State Well Number 1S/4W21Q03S

Basin: Colton-Rialto

Reference Point Elevation: 956.06

Date	Obtained from	Ref. Pt. to Water	Water Surface Elevation	Remarks
11/11/77	WMWD	86.30	869.76	Static
11/14/77	SBVMWD	85.96	870.1	Static
11/15/77	City of Riverside	85.30	870.76	Static
11/22/77	City of Riverside	86.30	869.76	Static
12/01/77	City of Riverside	85.80	870.26	Static
12/06/77	City of Riverside	86.40	869.66	Static (low)
12/13/77	City of Riverside	85.30	870.76	Static
12/14/77	SBVMWD	85.97	870.09	Static
12/20/77	City of Riverside	85.20	870.86	Static
12/27/77	City of Riverside	84.60	871.46	Static
1978				
01/01/78	City of Riverside	84.60	871.46	Static
01/10/78	City of Riverside	82.60	873.46	Static
01/14/78	SBVMWD	83.36	872.7	Static
01/17/78	City of Riverside	82.80	873.26	Static
01/24/78	City of Riverside	82.80	873.26	Static
01/31/78	City of Riverside	81.60	874.46	Static
02/07/78	City of Riverside	81.30	874.76	Static
02/14/78	City of Riverside	82.00	874.06	Static
02/16/78	SBVMWD	81.55	874.51	Static
02/17/78	WMWD	82.40	873.66	Static
02/21/78	City of Riverside	81.90	874.16	Static
02/28/78	City of Riverside	80.40	875.66	Static
03/14/78	City of Riverside	79.60	876.46	Static
03/16/78	WMWD	80.40	875.66	Static
03/16/78	SBVMWD	79.95	876.11	Static
03/21/78	City of Riverside	79.60	876.46	Static
03/29/78	City of Riverside	79.30	876.76	Static
04/05/78	City of Riverside	78.50	877.56	Static
04/11/78	City of Riverside	77.40	878.66	Static
04/11/78	SBVMWD	78.05	878.01	Static
04/18/78	City of Riverside	76.60	879.46	Pumping Nearby
04/25/78	City of Riverside	76.40	879.66	Static
04/27/78	WMWD	76.50	879.56	Static
05/10/78	SBVMWD	75.30	880.76	Static
05/10/78	City of Riverside	75.20	880.86	Static

**Western San Bernardino Watermaster
Well Measurement Record for**

Johnson #1

State Well Number 1S/4W21Q03S

Basin: Colton-Rialto

Reference Point Elevation: 956.06

Date	Obtained from	Ref. Pt. to Water	Water Surface Elevation	Remarks
05/17/78	City of Riverside	74.30	881.76	Static
05/25/78	City of Riverside	73.50	882.56	Static
06/07/78	City of Riverside	71.60	884.46	Static
06/13/78	City of Riverside	71.50	884.56	Static
06/13/78	WMWD	71.50	884.56	Static
06/14/78	SBVMWD	71.45	884.61	Static
06/20/78	City of Riverside	70.50	885.56	Static
06/28/78	City of Riverside	69.80	886.26	Static
07/04/78	City of Riverside	70.60	885.46	Static
07/11/78	SBVMWD	69.05	887.01	Static
07/11/78	City of Riverside	69.50	886.56	Static
08/01/78	City of Riverside	72.60	883.46	Static
08/02/78	WMWD	67.30	888.76	Static
08/08/78	City of Riverside	66.90	889.16	Static
08/09/78	SBVMWD	67.20	888.86	Static
08/15/78	City of Riverside	66.90	889.16	Static
08/22/78	City of Riverside	67.60	888.46	Static
08/29/78	City of Riverside	67.90	888.16	Static
09/04/78	City of Riverside	67.00	889.06	Static
09/12/78	City of Riverside	65.80	890.26	Static
09/13/78	SBVMWD	65.76	890.3	Static
09/13/78	WMWD	65.70	890.36	Static
09/20/78	City of Riverside	64.90	891.16	Static
09/26/78	City of Riverside	68.70	887.36	Pumping Nearby
10/01/78	City of Riverside	68.50	887.56	Pumping Nearby
10/09/78	City of Riverside	73.70	882.36	Pumping Nearby
10/11/78	SBVMWD	74.10	881.96	Static
10/17/78	City of Riverside	82.30	873.76	Pumping Nearby
10/24/78	City of Riverside	82.50	873.56	Pumping Nearby
10/26/78	WMWD	85.00	871.06	Pumping Nearby
11/06/78	City of Riverside	86.00	870.06	Pumping Nearby
11/14/78	City of Riverside	85.80	870.26	Pumping Nearby
11/15/78	SBVMWD	84.10	871.96	Pumping Nearby
11/21/78	City of Riverside	70.00	886.06	Static (low)
11/28/78	City of Riverside	68.20	887.86	Static (low)
12/05/78	City of Riverside	68.00	888.06	Static (low)
12/13/78	SBVMWD	64.80	891.26	Static (low)

**Western San Bernardino Watermaster
Well Measurement Record for**

Johnson #1

State Well Number 1S/4W21Q03S

Basin: Colton-Rialto

Reference Point Elevation: 956.06

Date	Obtained from	Ref. Pt. to Water	Water Surface Elevation	Remarks
12/19/78	City of Riverside	66.90	889.16	Static (low)
12/27/78	City of Riverside	66.30	889.76	Static (low)
1979				
01/02/79	City of Riverside	65.80	890.26	Static
01/09/79	City of Riverside	65.10	890.96	Static
01/16/79	City of Riverside	64.90	891.16	Static
01/17/79	SBVMWD	60.10	895.96	Reading Error?
01/30/79	City of Riverside	64.10	891.96	Static
02/05/79	WMWD	63.80	892.26	Static
02/06/79	City of Riverside	64.20	891.86	Static
02/14/79	City of Riverside	64.10	891.96	Static
02/15/79	SBVMWD	63.35	892.71	Static
02/20/79	City of Riverside	63.90	892.16	Static
03/01/79	City of Riverside	62.80	893.26	Static
03/07/79	WMWD	62.00	894.06	Static
03/07/79	City of Riverside	62.40	893.66	Static
03/14/79	City of Riverside	62.10	893.96	Static
03/15/79	SBVMWD	62.40	893.66	Static
03/20/79	City of Riverside	61.70	894.36	Static
03/27/79	City of Riverside	61.00	895.06	Static
04/05/79	City of Riverside	62.30	893.76	Static
04/10/79	City of Riverside	60.20	895.86	Static
04/11/79	SBVMWD	60.95	895.11	Static
04/18/79	City of Riverside	60.10	895.96	Static
04/25/79	City of Riverside	59.40	896.66	Static
05/03/79	City of Riverside	59.20	896.86	Static
05/16/79	SBVMWD	63.55	892.51	Static
05/22/79	WMWD	62.20	893.86	Static
05/22/79	City of Riverside	61.50	894.56	Static
05/29/79	City of Riverside	51.80	904.26	Reading Error?
06/01/79	City of Riverside	51.80	904.26	Reading Error?
06/05/79	City of Riverside	52.10	903.96	Reading Error?
06/11/79	SBVMWD	62.30	893.76	Static
06/12/79	City of Riverside	52.10	903.96	Reading Error?
06/19/79	City of Riverside	62.10	893.96	Static
06/26/79	City of Riverside	52.30	903.76	Reading Error?

**Western San Bernardino Watermaster
Well Measurement Record for**

Johnson #1

State Well Number 1S/4W21Q03S

Basin: Colton-Rialto

Reference Point Elevation: 956.06

Date	Obtained from	Ref. Pt. to Water	Water Surface Elevation	Remarks
07/03/79	City of Riverside	61.20	894.86	Static
07/10/79	City of Riverside	61.90	894.16	Static
07/11/79	SBVMWD	61.95	894.11	Static
08/01/79	City of Riverside	58.70	897.36	Reading Error?
08/08/79	SBVMWD	63.25	892.81	Static
08/21/79	WMWD	62.50	893.56	Static
08/28/79	City of Riverside	63.70	892.36	Static
09/05/79	City of Riverside	63.60	892.46	Static
09/13/79	SBVMWD	63.20	892.86	Static
10/11/79	SBVMWD	64.00	892.06	Low
10/16/79	City of Riverside	63.70	892.36	Static
10/23/79	City of Riverside	60.20	895.86	Static
10/30/79	City of Riverside	60.40	895.66	Static
11/06/79	City of Riverside	60.10	895.96	Static
11/13/79	City of Riverside	62.90	893.16	Static
11/15/79	SBVMWD	64.80	891.26	Static
11/16/79	WMWD	64.60	891.46	Static
11/21/79	City of Riverside	60.60	895.46	Static
11/27/79	City of Riverside	61.80	894.26	Static
12/17/79	SBVMWD	62.60	893.46	Static
1980				
01/21/80	SBVMWD	60.47	895.59	Static
01/18/80	WMWD	60.50	895.56	Static
01/21/80	SBVMWD	60.47	895.59	Static
02/04/80	WMWD	60.10	895.96	Static
02/14/80	SBVMWD	59.13	896.93	Static
03/04/80	City of Riverside	65.00	891.06	Static Reading Error?
03/14/80	SBVMWD	56.90	899.16	Static
04/04/80	City of Riverside	53.50	902.56	Static
04/08/80	WMWD	53.30	902.76	Static
04/16/80	SBVMWD	50.80	905.26	Static
05/05/80	City of Riverside	50.20	905.86	Static
05/16/80	SBVMWD	47.85	908.21	Static
05/21/80	City of Riverside	48.30	907.76	Static
06/12/80	SBVMWD	48.92	907.14	Static Reading Error?
07/22/80	SBVMWD	48.16	907.9	Static Reading Error?

**Western San Bernardino Watermaster
Well Measurement Record for**

Johnson #1

State Well Number 1S/4W21Q03S

Basin: Colton-Rialto

Reference Point Elevation: 956.06

Date	Obtained from	Ref. Pt. to Water	Water Surface Elevation	Remarks
08/13/80	SBVMWD	48.33	907.73	Static
08/13/80	WMWD	44.00	912.06	Static
09/08/80	WMWD	43.60	912.46	Static
09/16/80	City of Riverside	42.70	913.36	Static
09/17/80	SBVMWD	48.02	908.04	Static Reading Error?
09/30/80	City of Riverside	45.00	911.06	Static
10/01/80	City of Riverside	43.10	912.96	Static
10/15/80	City of Riverside	43.00	913.06	Static
10/21/80	City of Riverside	43.00	913.06	Static
10/23/80	SBVMWD	45.91	910.15	Static Reading Error?
10/28/80	City of Riverside	44.00	912.06	Static
11/03/80	WMWD	43.00	913.06	Static
11/04/80	City of Riverside	43.50	912.56	Static
11/11/80	City of Riverside	40.70	915.36	Static
11/18/80	City of Riverside	43.00	913.06	Static
11/25/80	SBVMWD	44.13	911.93	Low
12/18/80	SBVMWD	42.32	913.74	Static
12/23/80	WMWD	42.30	913.76	Static
1981				
01/06/81	City of Riverside	42.00	914.06	Static
01/15/81	SB	41.50	914.56	Static
01/15/81	City of Riverside	41.90	914.16	Static
01/20/81	City of Riverside	42.00	914.06	Static
01/27/81	City of Riverside	41.50	914.56	Static
02/03/81	City of Riverside	41.40	914.66	Static
02/10/81	City of Riverside	41.00	915.06	Static
02/11/81	SB	40.66	915.4	Static
02/17/81	City of Riverside	38.80	917.26	Static
02/24/81	City of Riverside	40.70	915.36	Static
02/24/81	WMWD	40.80	915.26	Static
03/03/81	City of Riverside	40.30	915.76	Static
03/10/81	City of Riverside	40.30	915.76	Static
03/11/81	SB	39.98	916.08	Static
03/17/81	City of Riverside	36.50	919.56	Static
03/25/81	City of Riverside	30.00	926.06	Static
03/27/81	WMWD	39.90	916.16	Static

**Western San Bernardino Watermaster
Well Measurement Record for**

Johnson #1

State Well Number 1S/4W21Q03S

Basin: Colton-Rialto

Reference Point Elevation: 956.06

Date	Obtained from	Ref. Pt. to Water	Water Surface Elevation	Remarks
04/07/81	City of Riverside	35.50	920.56	Static
04/14/81	SB	39.70	916.36	Static
04/15/81	City of Riverside	39.52	916.54	Static
04/21/81	City of Riverside	39.80	916.26	Static
05/01/81	City of Riverside	39.80	916.26	Static
05/07/81	WMWD	39.24	916.82	Static
05/14/81	SB	39.08	916.98	Static
05/29/81	City of Riverside	38.30	917.76	Static
06/15/81	SB	41.20	914.86	Static
06/20/81	City of Riverside	39.50	916.56	Static
06/29/81	City of Riverside	40.00	916.06	Static
07/10/81	City of Riverside	39.20	916.86	Static
07/16/81	SB	42.45	913.61	Static
07/22/81	City of Riverside	39.40	916.66	Static
07/29/81	City of Riverside	41.20	914.86	Static
08/13/81	SB	43.00	913.06	Low
08/18/81	WMWD	39.40	916.66	Static
08/19/81	City of Riverside	39.10	916.96	Static
08/26/81	City of Riverside	39.40	916.66	Static
09/15/81	SB	42.30	913.76	Static
10/16/81	SB	41.50	914.56	Static
10/27/81	City of Riverside	38.10	917.96	Static
11/10/81	WMWD	39.80	916.26	Static
11/20/81	SB	40.25	915.81	Static
12/01/81	City of Riverside	30.50	925.56	Reading Error?
12/22/81	WMWD	40.90	915.16	Static
12/31/81	City of Riverside	40.00	916.06	Static
1982				
01/05/82	City of Riverside	40.30	915.76	
01/14/82	City of Riverside	39.40	916.66	
02/16/82	City of Riverside	37.00	919.06	
02/19/82	City of Riverside	38.80	917.26	
03/16/82	City of Riverside	38.00	918.06	
05/02/82	City of Riverside	36.90	919.16	
05/10/82	WMWD	40.60	915.46	(?)
06/01/82	City of Riverside	37.00	919.06	

**Western San Bernardino Watermaster
Well Measurement Record for**

Johnson #1

State Well Number 1S/4W21Q03S

Basin: Colton-Rialto

Reference Point Elevation: 956.06

Date	Obtained from	Ref. Pt. to Water	Water Surface Elevation	Remarks
06/08/82	City of Riverside	37.00	919.06	
08/06/82	City of Riverside	41.50	914.56	Low
09/14/82	City of Riverside	39.80	916.26	
09/30/82	City of Riverside	38.50	917.56	
10/14/82	City of Riverside	40.30	915.76	
11/03/82	City of Riverside	39.80	916.26	
12/14/82	City of Riverside	40.00	916.06	
12/27/82	WMWD	37.60	918.46	
1983				
01/04/83	City of Riverside	39.50	916.56	Low
04/01/83	City of Riverside	35.30	920.76	
04/04/83	City of Riverside	34.80	921.26	
04/11/83	City of Riverside	33.80	922.26	
04/19/83	City of Riverside	34.10	921.96	
04/26/83	City of Riverside	35.00	921.06	
05/01/83	City of Riverside	35.00	921.06	
05/03/83	City of Riverside	34.00	922.06	
05/10/83	City of Riverside	33.80	922.26	
05/24/83	City of Riverside	34.60	921.46	
05/29/83	City of Riverside	32.20	923.86	
06/21/83	City of Riverside	32.00	924.06	
06/29/83	City of Riverside	33.50	922.56	
07/12/83	City of Riverside	33.00	923.06	
07/19/83	City of Riverside	33.30	922.76	
07/26/83	City of Riverside	33.50	922.56	
08/30/83	City of Riverside	33.90	922.16	
09/01/83	City of Riverside	33.90	922.16	
09/01/83	WMWD	33.10	922.96	
09/06/83	City of Riverside	33.00	923.06	
09/13/83	City of Riverside	33.00	923.06	
09/20/83	City of Riverside	33.00	923.06	
09/27/83	City of Riverside	32.90	923.16	
10/04/83	City of Riverside	32.80	923.26	
10/18/83	City of Riverside	32.90	923.16	
10/25/83	City of Riverside	32.60	923.46	
11/01/83	City of Riverside	32.60	923.46	

**Western San Bernardino Watermaster
Well Measurement Record for**

Johnson #1

State Well Number 1S/4W21Q03S

Basin: Colton-Rialto

Reference Point Elevation: 956.06

Date	Obtained from	Ref. Pt. to Water	Water Surface Elevation	Remarks
11/01/83	WMWD	32.60	923.46	
11/08/83	City of Riverside	32.60	923.46	
11/16/83	City of Riverside	32.40	923.66	
11/22/83	City of Riverside	32.50	923.56	
12/01/83	City of Riverside	32.20	923.86	
12/06/83	City of Riverside	32.30	923.76	
12/20/83	City of Riverside	31.50	924.56	
12/27/83	City of Riverside	32.00	924.06	
1984				
01/01/84	City of Riverside	31.50	924.56	
01/10/84	City of Riverside	31.70	924.36	
01/17/84	City of Riverside	31.50	924.56	
01/24/84	City of Riverside	31.60	924.46	
02/01/84	City of Riverside	31.40	924.66	
02/07/84	City of Riverside	31.60	924.46	
02/14/84	City of Riverside	31.40	924.66	
02/21/84	City of Riverside	32.50	923.56	
03/01/84	City of Riverside	34.30	921.76	
03/08/84	City of Riverside	35.80	920.26	
03/20/84	City of Riverside	36.40	919.66	
04/01/84	City of Riverside	33.20	922.86	
04/03/84	City of Riverside	33.70	922.36	
04/25/84	City of Riverside	34.50	921.56	
04/30/84	City of Riverside	33.70	922.36	
05/01/84	City of Riverside	37.00	919.06	
05/08/84	City of Riverside	37.60	918.46	
05/15/84	City of Riverside	37.80	918.26	
05/22/84	City of Riverside	39.00	917.06	
06/01/84	City of Riverside	39.00	917.06	
06/12/84	City of Riverside	38.20	917.86	
06/19/84	City of Riverside	38.40	917.66	
07/01/84	City of Riverside	39.10	916.96	
07/10/84	City of Riverside	36.50	919.56	
08/01/84	City of Riverside	34.00	922.06	
09/01/84	City of Riverside	39.00	917.06	
10/01/84	City of Riverside	40.60	915.46	

**Western San Bernardino Watermaster
Well Measurement Record for**

Johnson #1

State Well Number 1S/4W21Q03S

Basin: Colton-Rialto

Reference Point Elevation: 956.06

Date	Obtained from	Ref. Pt. to Water	Water Surface Elevation	Remarks
10/02/84	WMWD	41.30	914.76	Low
11/01/84	City of Riverside	40.60	915.46	
12/01/84	City of Riverside	35.50	920.56	

**Western San Bernardino Watermaster
Well Measurement Record for**

Johnson #1

State Well Number 1S/4W21Q03S

Basin: Colton-Rialto

Reference Point Elevation: 956.06

RP Elevation #2, top of MP: 960

RP Elevation #3, top of MP: 959.37

RP Elevation #4, top of 4" coupling in new box 954.5

RP #5 inside well lid 957.14 see note in comment box

Date	Obtained from	Ref. Pt. to Water	Water Surface Elevation	Remarks
1985				
02/01/85	City of Riverside	33.50	922.56	
03/01/85	City of Riverside	31.20	924.86	
03/05/85	City of Riverside	33.30	922.76	
03/12/85	City of Riverside	33.00	923.06	
03/19/85	City of Riverside	36.50	919.56	
04/01/85	City of Riverside	29.80	926.26	
04/09/85	City of Riverside	30.70	925.36	
04/23/85	City of Riverside	32.70	923.36	
05/01/85	City of Riverside	32.70	923.36	
06/11/85	City of Riverside	38.40	917.66	
09/01/85	City of Riverside	37.40	918.66	
10/01/85	City of Riverside	44.10	911.96	
12/01/85	City of Riverside	46.40	909.66	Low for year
1986				
01/01/86	City of Riverside	43.00	913.06	
02/01/86	City of Riverside	37.40	918.66	
02/11/86	City of Riverside	37.40	918.66	
03/04/86	City of Riverside	36.40	919.66	
03/25/86	City of Riverside	35.40	920.66	
04/01/86	City of Riverside	35.20	920.86	
04/08/86	City of Riverside	35.00	921.06	
05/06/86	City of Riverside	38.40	917.66	
05/13/86	City of Riverside	38.70	917.36	
05/20/86	City of Riverside	38.90	917.16	
06/11/86	Western MWD	39.90	916.16	
06/17/86	City of Riverside	40.00	916.06	
07/20/91	City of Riverside	40.70	915.36	
08/05/86	City of Riverside	40.30	915.76	
08/12/86	City of Riverside	40.50	915.56	
08/26/86	City of Riverside	41.30	914.76	
09/02/86	City of Riverside	41.70	914.36	
09/16/86	Western MWD	42.10	913.96	
09/23/86	City of Riverside	42.20	913.86	Low for the year
10/24/86	Western MWD	39.20	916.86	
11/19/86	City of Riverside	38.70	917.36	
12/29/86	City of Riverside	38.70	917.36	

**Western San Bernardino Watermaster
Well Measurement Record for**

Johnson #1

State Well Number 1S/4W21Q03S

Basin: Colton-Rialto

Reference Point Elevation: 956.06

RP Elevation #2, top of MP: 960

RP Elevation #3, top of MP: 959.37

RP Elevation #4, top of 4" coupling in new box 954.5

RP #5 inside well lid 957.14 see note in comment box

Date	Obtained from	Ref. Pt. to Water	Water Surface Elevation	Remarks
1987				
01/06/87	Western MWD	40.60	915.46	
01/19/87	City of Riverside	42.30	913.76	
01/28/87	City of Riverside	34.20	921.86	
03/03/87	City of Riverside	37.90	918.16	
03/31/87	City of Riverside	37.80	918.26	
04/20/87	Western MWD	39.50	916.56	
04/30/87	City of Riverside	40.00	916.06	
06/10/87	City of Riverside	40.00	916.06	
07/06/87	City of Riverside	43.80	912.26	
08/09/87	City of Riverside	46.10	909.96	
08/16/87	City of Riverside	46.70	909.36	Low for the year
08/25/87	City of Riverside	30.90	925.16	?
09/24/87	City of Riverside	44.40	911.66	
11/03/87	City of Riverside	47.00	909.06	?
11/10/87	City of Riverside	43.30	912.76	
12/08/87	City of Riverside	42.10	913.96	
12/22/87	City of Riverside	42.00	914.06	
12/23/87	Western MWD	41.20	914.86	
12/29/87	City of Riverside	41.20	914.86	
1988				
01/05/88	City of Riverside	40.70	915.36	
01/12/88	City of Riverside	42.10	913.96	
01/26/88	City of Riverside	40.50	915.56	
03/01/88	City of Riverside	40.00	916.06	
03/08/88	City of Riverside	40.10	915.96	
04/15/88	City of Riverside	41.20	914.86	
05/01/88	City of Riverside	40.70	915.36	
06/28/88	City of Riverside	48.80	907.26	
07/01/88	City of Riverside	48.80	907.26	
07/05/88	City of Riverside	52.50	903.56	
07/12/88	City of Riverside	50.80	905.26	
08/01/88	City of Riverside	43.20	912.86	
08/17/88	City of Riverside	50.80	905.26	
09/01/88	City of Riverside	52.80	903.26	Low for the year
10/01/88	City of Riverside	52.80	903.26	
11/01/88	City of Riverside	50.50	905.56	

**Western San Bernardino Watermaster
Well Measurement Record for**

Johnson #1

State Well Number 1S/4W21Q03S

Basin: Colton-Rialto

Reference Point Elevation: 956.06

RP Elevation #2, top of MP: 960

RP Elevation #3, top of MP: 959.37

RP Elevation #4, top of 4" coupling in new box 954.5

RP #5 inside well lid 957.14 see note in comment box

Date	Obtained from	Ref. Pt. to Water	Water Surface Elevation	Remarks
1989				
01/01/89	City of Riverside	49.90	906.16	
01/26/89	City of Riverside	54.30	901.76	
02/01/89	City of Riverside	54.30	901.76	
02/09/89	City of Riverside	51.80	904.26	
02/22/89	City of Riverside	48.90	907.16	
03/01/89	City of Riverside	48.90	907.16	
03/12/89	City of Riverside	48.30	907.76	
03/19/89	City of Riverside	49.20	906.86	
03/25/89	City of Riverside	53.20	902.86	
04/28/89	City of Riverside	43.80	912.26	
05/05/89	City of Riverside	46.90	909.16	
05/11/89	City of Riverside	47.30	908.76	
06/12/89	City of Riverside	48.70	907.36	
06/16/89	City of Riverside	48.50	907.56	
06/30/89	City of Riverside	48.20	907.86	
08/31/89	City of Riverside	51.10	904.96	
09/26/89	City of Riverside	56.40	899.66	
10/11/89	City of Riverside	56.10	899.96	
10/17/89	City of Riverside	56.70	899.36	
10/31/89	City of Riverside	53.50	902.56	
11/10/89	City of Riverside	56.50	899.56	
11/18/89	City of Riverside	56.50	899.56	
11/24/89	City of Riverside	56.50	899.56	
12/01/89	City of Riverside	57.00	899.06	Low for the year
12/09/89	City of Riverside	56.80	899.26	
12/16/89	City of Riverside	56.00	900.06	
12/23/89	City of Riverside	54.00	902.06	
12/31/89	City of Riverside	53.30	902.76	
1990				
01/06/90	City of Riverside	51.70	904.36	
01/13/90	City of Riverside	54.50	901.56	
01/19/90	City of Riverside	53.00	903.06	
01/25/90	City of Riverside	52.50	903.56	
02/03/90	City of Riverside	52.50	903.56	
02/10/90	City of Riverside	52.00	904.06	
02/24/90	City of Riverside	60.00	896.06	?
02/27/90	City of Riverside	51.50	904.56	

**Western San Bernardino Watermaster
Well Measurement Record for**

Johnson #1

State Well Number 1S/4W21Q03S

Basin: Colton-Rialto

Reference Point Elevation: 956.06

RP Elevation #2, top of MP: 960

RP Elevation #3, top of MP: 959.37

RP Elevation #4, top of 4" coupling in new box 954.5

RP #5 inside well lid 957.14 see note in comment box

Date	Obtained from	Ref. Pt. to Water	Water Surface Elevation	Remarks
03/07/90	City of Riverside	51.50	904.56	
03/10/90	City of Riverside	51.50	904.56	
03/14/90	City of Riverside	51.50	904.56	
04/02/90	City of Riverside	51.00	905.06	
04/05/90	City of Riverside	51.00	905.06	
05/22/90	Western MWD	51.50	904.56	
06/08/90	City of Riverside	59.30	896.76	
07/09/90	City of Riverside	56.90	899.16	
08/03/90	City of Riverside	59.60	896.46	
09/20/90	City of Riverside	58.30	897.76	
10/31/90	City of Riverside	57.00	899.06	
12/01/90	City of Riverside	59.20	896.86	Low for the year
12/12/90	Western MWD	58.40	897.66	
1991				
01/15/91	City of Riverside	55.50	900.56	
01/28/91	City of Riverside	55.00	901.06	
03/04/91	City of Riverside	55.40	900.66	
03/30/91	City of Riverside	54.90	901.16	
04/16/91	City of Riverside	53.60	902.46	
04/29/91	City of Riverside	55.80	900.26	
05/13/91	City of Riverside	60.10	895.96	
05/31/91	Western MWD	59.05	897.01	
08/23/91	City of Riverside	66.00	890.06	
10/10/91	City of Riverside	66.00	890.06	Low for the year
1992				
01/16/92	Western MWD	59.26	896.80	
02/03/92	City of Riverside	49.80	906.26	
02/23/92	City of Riverside	60.10	895.96	
03/11/92	City of Riverside	57.00	899.06	
04/07/92	City of Riverside	58.60	897.46	
11/27/92	City of Riverside	67.50	888.56	Low for the year
12/16/92	City of Riverside	83.00	884.16	Colton Pumping (?)
1993				
01/23/93	City of Riverside	67.10	888.96	
01/25/93	Western MWD	71.90	884.16	Colton Pumping
03/15/93	City of Riverside	67.00	889.06	

**Western San Bernardino Watermaster
Well Measurement Record for**

Johnson #1

State Well Number 1S/4W21Q03S

Basin: Colton-Rialto

Reference Point Elevation: 956.06

RP Elevation #2, top of MP: 960

RP Elevation #3, top of MP: 959.37

RP Elevation #4, top of 4" coupling in new box 954.5

RP #5 inside well lid 957.14 see note in comment box

Date	Obtained from	Ref. Pt. to Water	Water Surface Elevation	Remarks
04/21/93	City of Riverside	67.20	888.86	
05/18/93	City of Riverside	70.20	885.86	Low for the year
06/09/93	City of Riverside	70.00	886.06	
08/30/93	City of Riverside	67.00	889.06	
09/07/94	City of Riverside	67.30	888.76	
10/25/93	City of Riverside	65.00	891.06	
12/28/93	City of Riverside	63.20	892.86	
1994				
01/03/94	Western MWD	48.25	907.81	
02/23/94	City of Riverside	58.20	897.86	
05/25/94	City of Riverside	48.10	907.96	
05/31/94	Western MWD	43.60	912.46	
11/23/94	City of Riverside	53.50	902.56	
12/06/94	Western MWD	53.50	902.56	Low for the year
12/21/94	City of Riverside	57.20	898.86	
1995				
05/08/95	City of Riverside	40.40	915.66	
05/24/95	Western MWD	41.40	914.66	
09/29/95	City of Riverside	56.00	900.06	
12/05/96	City of Riverside	61.00	895.06	Low for the year
1996				
02/03/96	City of Riverside	53.00	907.00	
02/23/96	City of Riverside	61.00	895.06	
03/07/96	Western MWD	45.20	910.86	
04/12/96	Western MWD/SBVMWD	57.75	902.25	
04/30/96	City of Riverside	58.00	902.00	
05/10/96	Western MWD	59.70	900.30	#23 pumping
05/14/96	SBVMWD	58.90	901.10	#23 pumping
05/30/96	City of Riverside	65.00	895.00	
06/14/96	SBVMWD	63.10	896.90	#23 pumping
07/01/96	City of Riverside	66.70	893.30	
07/05/96	Western MWD	66.42	893.58	#23 & #36 pumping
07/19/96	SBVMWD	67.40	892.60	#23 & #36 pumping
08/06/96	Western MWD	64.75	895.25	#23 pumping
08/20/96	SBVMWD	65.20	894.80	#23 pumping
09/30/96	City of Riverside	65.10	894.90	Low for the year

**Western San Bernardino Watermaster
Well Measurement Record for**

Johnson #1

State Well Number 1S/4W21Q03S

Basin: Colton-Rialto

Reference Point Elevation: 956.06

RP Elevation #2, top of MP: 960

RP Elevation #3, top of MP: 959.37

RP Elevation #4, top of 4" coupling in new box 954.5

RP #5 inside well lid 957.14 see note in comment box

Date	Obtained from	Ref. Pt. to Water	Water Surface Elevation	Remarks
10/16/96	SBVMWD	72.40	887.60	#23 pumping
11/04/96	Western MWD	74.33	885.67	#23 & #36 pumping
11/18/96	SBVMWD	70.70	889.30	#23 pumping
12/09/96	Western MWD	70.05	889.95	#23 pumping
12/17/96	SBVMWD	69.20	890.80	#23 pumping
1997				
01/03/97	City of Riverside	61.70	898.30	?
01/16/97	SBVMWD	68.90	891.10	#23 pumping
02/19/97	SBVMWD	65.70	894.30	#23 pumping
03/18/97	SBVMWD	63.60	896.40	#23 pumping
03/30/97	City of Riverside	54.90	905.10	?
04/18/97	SBVMWD	64.40	895.60	#23 pumping
05/05/97	Western MWD	65.80	894.20	#23 pumping
05/20/97	SBVMWD	65.25	894.75	#23 pumping
06/17/97	SBVMWD	65.80	894.20	#23 pumping
07/16/97	SBVMWD	67.00	893.00	#23 pumping
09/16/97	SBVMWD	67.50	892.50	#36 pumping
10/16/97	SBVMWD	69.80	890.20	#23 pumping
11/18/97	SBVMWD	63.50	896.50	Low for the year
12/16/97	SBVMWD	60.80	899.20	
12/29/97	Western MWD	70.10	889.90	#23 pumping
1998				
01/10/98	City of Riverside	71.50	888.50	
02/19/98	SBVMWD	59.40	900.60	
02/21/98	City of Riverside	59.30	900.70	
04/08/98	City of Riverside	56.00	904.00	
04/20/98	SBVMWD	58.00	902.00	#23 pumping
06/01/98	Western MWD	60.20	899.80	#23 pumping
06/18/98	SBVMWD	58.70	901.30	#23 pumping
07/14/98	SBVMWD	56.70	903.30	#23 pumping
08/05/98	City of Riverside	56.80	903.20	
08/17/98	SBVMWD	55.50	904.50	#23 pumping
09/17/98	SBVMWD	55.40	904.60	#23 pumping
11/10/98	SBVMWD	54.50	905.50	#23 pumping
12/18/98	SBVMWD	54.20	905.80	#23 pumping / low for year

**Western San Bernardino Watermaster
Well Measurement Record for**

Johnson #1

State Well Number 1S/4W21Q03S

Basin: Colton-Rialto

Reference Point Elevation: 956.06

RP Elevation #2, top of MP: 960

RP Elevation #3, top of MP: 959.37

RP Elevation #4, top of 4" coupling in new box 954.5

RP #5 inside well lid 957.14 see note in comment box

Date	Obtained from	Ref. Pt. to Water	Water Surface Elevation	Remarks
1999				
01/08/99	City of Riverside	48.50	911.50	
01/18/99	Western MWD	48.70	911.30	
01/19/99	SBVMWD	48.60	911.40	
02/16/99	SBVMWD	51.50	908.50	#23 pumping
03/17/99	SBVMWD	46.60	913.40	
04/14/99	SBVMWD	49.40	910.60	#23 off, #36 on
05/20/99	City of Riverside	54.00	906.00	
06/03/99	Western MWD	46.00	914.00	#36 pumping
06/16/99	SBVMWD	50.30	909.70	#23 off, #36 on
07/13/99	SBVMWD	58.60	901.40	#23 on, #36 on
08/05/99	City of Riverside	59.60	900.40	
08/17/99	SBVMWD	60.30	899.70	#23 on, #36 on
09/14/99	SBVMWD	61.10	898.90	#23 on, #36 on
10/07/99	City of Riverside	57.60	902.40	
10/15/99	SBVMWD	58.36	901.64	#23 on, #36 off
11/17/99	SBVMWD	51.94	908.06	#23 off, #36 off
12/14/99	SBVMWD	57.32	902.68	#23 off, #36 on
12/28/99	Western MWD	57.77	902.23	#23 off, #36 off / low for year
2000				
01/14/00	SBVMWD	58.38	901.62	#23 off, #36 on
01/18/00	City of Riverside	53.90	906.10	
02/14/00	SBVMWD	59.10	900.90	#23 off, #36 off
03/13/00	SBVMWD	52.42	907.58	#23 off, #36 off
03/21/00	City of Riverside	52.40	907.60	
04/12/00	SBVMWD	51.46	908.54	#23 off/#36 not equipped
05/09/00	Western MWD	58.63	901.37	#23 on/#36 not equipped
05/12/00	SBVMWD	58.00	902.00	#23 on/#36 not equipped
06/13/00	SBVMWD	59.10	900.90	#23 on/#36 not equipped
07/13/00	SBVMWD	59.42	900.58	#23 on/#36 off
08/14/00	SBVMWD	59.60	900.40	#23 on/#36 off
09/15/00	SBVMWD	61.48	898.52	#23 on/#36 off
09/18/00	City of Riverside	60.80	899.20	low for year
10/16/00	SBVMWD	55.46	904.54	#23 off, #36 off
11/16/00	SBVMWD	64.30	895.70	#23 on/#36 off
12/04/00	City of Riverside			Cannot measure
12/18/00	SBVMWD	65.64	894.36	#23 on/#36 off

**Western San Bernardino Watermaster
Well Measurement Record for**

Johnson #1

State Well Number 1S/4W21Q03S

Basin: Colton-Rialto

Reference Point Elevation: 956.06

RP Elevation #2, top of MP: 960

RP Elevation #3, top of MP: 959.37

RP Elevation #4, top of 4" coupling in new box 954.5

RP #5 inside well lid 957.14 see note in comment box

Date	Obtained from	Ref. Pt. to Water	Water Surface Elevation	Remarks
2001				
01/17/01	SBVMWD	61.58	898.42	#23 off/#36 off
01/19/01	City of Riverside	61.40	898.60	
02/16/01	City of Riverside	60.50	899.50	
02/16/01	SBVMWD	60.96	899.04	#23 off/#36 off
03/09/01	Western MWD	59.80	900.20	#23 on/#36 off
03/16/01	SBVMWD	64.84	895.16	#23 on/#36 off
04/18/01	SBVMWD	64.00	896.00	#23 on/#36 off
04/23/01	City of Riverside	64.60	895.40	
05/18/01	SBVMWD	63.70	896.30	#23 on/#36 off
06/08/01	Western MWD	63.73	896.27	#23 on/#36 off
06/18/01	SBVMWD	64.00	896.00	#23 on/#36 off
07/18/01	SBVMWD	63.74	896.26	#23 on/#36 off
08/20/01	SBVMWD	66.40	893.60	#23 on/#36 on
09/24/01	SBVMWD	67.80	892.20	#23 on/#36 on
10/16/01	SBVMWD	68.30	891.70	#23 on/#36 on
11/14/01	SBVMWD	67.90	892.10	#23 on/#36 on
11/16/01	Western MWD	69.78	890.22	#23 on/#36 on
12/04/01	City of Riverside	68.80	891.20	LOW
12/17/01	SBVMWD	67.76	892.24	#23 on/#36 off
2002				
01/12/02	City of Riverside	68.40	891.60	
01/17/02	SBVMWD	67.74	892.26	#23 on/#36 off
02/14/02	City of Riverside	68.70	891.30	
02/15/02	SBVMWD	68.40	891.60	#23 on/#36 off
03/18/02	SBVMWD	69.70	890.30	#23 on/#36 on
03/28/02	City of Riverside	71.10	888.90	
04/15/02	SBVMWD	71.32	888.68	#23 on/#36 on
05/01/02	Western MWD	71.96	888.04	#23 on/#36 on
05/03/02	City of Riverside	73.00	887.00	Static
05/16/02	SBVMWD	72.20	887.80	#23 on/#36 on
06/14/02	SBVMWD	73.60	886.40	#23 on/#36 on
07/10/02	SBVMWD	76.00	884.00	#23 on/#36 on
07/31/02	City of Riverside	77.00	883.00	Static
08/14/02	SBVMWD	77.10	882.90	#23 on/#36 on
09/11/02	City of Riverside	80.00	880.00	Static
09/13/02	SBVMWD	79.70	880.30	#23 on/#36 off
10/16/02	SBVMWD	83.34	876.66	#23 on/#36 on

**Western San Bernardino Watermaster
Well Measurement Record for**

Johnson #1

State Well Number 1S/4W21Q03S

Basin: Colton-Rialto

Reference Point Elevation: 956.06

RP Elevation #2, top of MP: 960

RP Elevation #3, top of MP: 959.37

RP Elevation #4, top of 4" coupling in new box 954.5

RP #5 inside well lid 957.14 see note in comment box

Date	Obtained from	Ref. Pt. to Water	Water Surface Elevation	Remarks
11/12/02	City of Riverside	79.00	881.00	Static, LOW
11/16/02	Western MWD	69.78	890.22	#23 on/#36 on ?
11/22/02	SBVMWD	84.40	875.60	#23 on/#36 on
12/11/02	Western MWD	84.76	875.24	#23 on/#36 on
12/18/02	SBVMWD	76.50	883.50	#23 off/#36 off
12/25/02	City of Riverside	81.30	878.70	Static
2003				
01/13/03	SBVMWD	77.20	882.80	#23 off/#36 off
02/13/03	SBVMWD	78.80	881.20	#23 on/#36 off
03/05/03	City of Riverside	78.40	881.60	
03/26/03	SBVMWD	82.80	877.20	#23 on/#36 off
04/15/03	SBVMWD	78.00	882.00	#23 on, #36 off
05/08/03	SBVMWD	81.00	879.00	#23 on, #36 off
05/08/03	WMWD	80.88	879.12	
06/18/03	SBVMWD	79.20	880.80	#23 on, #36 on
07/17/03	SBVMWD	81.82	878.18	#23 on, #36 off
08/13/03	SBVMWD	83.05	876.95	#23 on, #36 off
08/18/04	City of Riverside	86.60	873.40	
09/12/03	SBVMWD	86.00	874.00	#23 on, #36 on
10/24/03	SBVMWD	87.90	872.10	#23 on, #36 on
11/14/03	SBVMWD	85.40	874.60	#23 on, #36 on
12/08/03	WMWD	84.32	875.68	#23 off, #36 on / LOW
12/17/03	SBVMWD	81.40	878.60	#23 off, #36 off
2004				
01/21/04	SBVMWD	84.70	875.30	#23 on, #36 off
02/23/04	SBVMWD	80.60	879.40	#23 off, #36 off
03/09/04	City of Riverside	79.90	880.10	
03/25/04	SBVMWD	81.40	878.60	#23 off, #36 off
04/07/04	City of Riverside	83.00	877.00	
04/16/04	SBVMWD	81.37	878.63	#23 on, #36 off
05/03/04	WMWD	85.56	874.44	#23 on, #36 off
05/11/04	City of Riverside	83.00	877.00	Date estimated
05/13/04	SBVMWD	85.40	874.60	#23 on, #36 off
06/15/04	SBVMWD	85.80	874.20	#23 on, #36 off
07/15/04	City of Riverside	86.80	873.20	Date estimated
07/15/04	SBVMWD	86.72	873.28	#23 on, #36 off
08/19/04	SBVMWD	87.00	873.00	#23 on, #36 off

**Western San Bernardino Watermaster
Well Measurement Record for**

Johnson #1

State Well Number 1S/4W21Q03S

Basin: Colton-Rialto

Reference Point Elevation: 956.06

RP Elevation #2, top of MP: 960

RP Elevation #3, top of MP: 959.37

RP Elevation #4, top of 4" coupling in new box 954.5

RP #5 inside well lid 957.14 see note in comment box

Date	Obtained from	Ref. Pt. to Water	Water Surface Elevation	Remarks
09/15/04	City of Riverside	86.60	873.40	Date estimated
09/20/04	SBVMWD	86.60	873.40	#23 on, #36 off
10/18/04	SBVMWD	87.00	873.00	#23 on, #36 off
11/15/04	WMWD	87.30	872.70	LOW
11/15/04	SBVMWD	87.40	872.60	#23 on, #36 off
12/16/04	SBVMWD	87.60	872.40	#23 off, #36 off
2005				
01/15/05	C of R	81.20	878.8	Static
01/18/05	SBVMWD	84.60	875.40	#23 on, #36 off
02/28/05	SBVMWD	76.50	883.50	#23 off, #36 off
03/21/05	SBVMWD	74.50	885.50	#23 off, #36 off
04/15/05	C of R	81.90	878.10	Static
04/18/05	SBVMWD	78.90	881.10	#23 on, #36 off
04/21/05	WMWD	78.60	881.40	#23 on, #36 off
05/13/05	SBVMWD	76.58	883.42	#23 on, #36 off
05/27/05	WMWD	75.61	884.39	#23 on, #36 off
06/14/05	SBVMWD	74.70	885.30	#23 on, #36 off
07/14/05	SBVMWD	72.40	887.60	#23 on, #36 off
07/15/05	C of R	71.00	889.00	Static
08/14/05	SBVMWD	71.00	889.00	#23 on, #36 off
09/19/05	SBVMWD	69.80	890.20	#23 on, #36 off
10/10/05	WMWD	70.38	889.62	#23 on, #36 off
10/19/05	SBVMWD	69.00	891.00	#23 on, #36 off
11/11/05	WMWD	72.28	887.72	#23 on, #36 off
11/14/05	WMWD	70.72	889.28	#23 on, #36 off
11/15/05	C of R	71.20	888.80	Static
11/28/05	SBVMWD	71.60	888.40	#23 on, #36 off / Low
12/12/05	WMWD	71.11	888.89	#23 on, #36 off
12/13/05	SBVMWD	71.20	888.80	#23 on, #36 off
2006				
01/10/06	WMWD	72.33	887.67	#23 on, #36 off
01/11/06	SBVMWD	72.40	887.60	#23 on, #36 off
01/11/06	WMWD	72.28	887.72	#23 on, #36 off
02/13/06	WMWD	73.00	887.00	#23 on, #36 off
02/14/06	SBVMWD	73.12	886.88	#23 on, #36 off
03/13/06	WMWD	70.99	889.01	#23 off, #36 off
03/22/06	SBVMWD	73.00	887.00	#23 on, #36 off

**Western San Bernardino Watermaster
Well Measurement Record for**

Johnson #1

State Well Number 1S/4W21Q03S

Basin: Colton-Rialto

Reference Point Elevation: 956.06

RP Elevation #2, top of MP: 960

RP Elevation #3, top of MP: 959.37

RP Elevation #4, top of 4" coupling in new box 954.5

RP #5 inside well lid 957.14 see note in comment box

Date	Obtained from	Ref. Pt. to Water	Water Surface Elevation	Remarks
04/10/06	SBVMWD	71.80	888.20	#23 on, #36 off
04/10/06	WMWD	71.60	888.40	#23 on, #36 off
05/08/06	WMWD	71.50	888.50	#23 on, #36 off
05/12/06	SBVMWD	72.00	888.00	#23 on, #36 off
06/10/06	WMWD	68.52	891.48	#23 on, #36 off
06/13/06	SBVMWD	67.80	892.20	#23 on, #36 off
07/09/06	C of R	69.20	890.80	Static
07/11/06	WMWD	68.72	891.28	#23 on, #36 off
07/13/06	SBVMWD	69.00	891.00	#23 on, #36 off
08/14/06	WMWD	71.22	888.78	#23 on, #36 on
08/20/06	SBVMWD	71.60	888.40	#23 on, #36 off
09/11/06	WMWD	73.43	886.57	#23 on, #36 on
09/25/06	SBVMWD	70.40	889.60	#23 on, #36 off
10/04/06	C of R	99.00	861.00	Static - Watermaster challenges
10/09/06	WMWD	67.10	892.90	#23 off, #36 off / LOW
10/25/06	SBVMWD	73.30	886.70	#23 on, #36 off
11/13/06	WMWD	74.56	885.44	#23 on, #36 off
11/21/06	SBVMWD	74.00	886.00	#23 on, #36 off
12/11/06	WMWD	73.38	886.62	#23 off, #36 off
12/21/06	SBVMWD	74.00	886.00	#23 on, #36 off
2007				
01/08/07	WMWD	74.08	885.92	#23 on, #36 off
01/14/07	C of R	76.00	884.00	
01/22/07	SBVMWD	68.50	891.50	#23 off, #36 off
02/01/07	WMWD	72.03	887.97	#23 on, #36 off
02/15/07	SBVMWD	72.50	887.50	#23 off, #36 off
02/21/07	C of R	-	-	
03/12/07	WMWD	75.43	884.57	#23 on, #36 off
03/23/07	SBVMWD	74.80	885.20	#23 on, #36 off
04/11/07	WMWD	75.21	884.79	#23 on, #36 off
04/12/07	C of R	80.00	880.00	
04/27/07	SBVMWD	74.70	885.30	#23 on, #36 off
05/14/07	WMWD	74.94	885.06	#23 on, #36 off
05/16/07	C of R	75.00	885.00	
05/25/07	SBVMWD	76.20	883.80	#23 on, #36 off
06/09/07	C of R	78.20	881.80	
06/11/07	WMWD	79.19	880.81	#23 on, #36 off
06/14/07	SBVMWD	79.80	880.20	#23 on, #36 off

**Western San Bernardino Watermaster
Well Measurement Record for**

Johnson #1

State Well Number 1S/4W21Q03S

Basin: Colton-Rialto

Reference Point Elevation: 956.06

RP Elevation #2, top of MP: 960

RP Elevation #3, top of MP: 959.37

RP Elevation #4, top of 4" coupling in new box 954.5

RP #5 inside well lid 957.14 see note in comment box

Date	Obtained from	Ref. Pt. to Water	Water Surface Elevation	Remarks
07/10/07	C of R	79.40	880.60	
07/11/07	WMWD	81.43	878.57	#23 on, #36 off
07/19/07	SBVMWD	81.00	879.00	#23 on, #36 off
08/09/07	C of R	84.00	876.00	
08/12/07	WMWD	82.55	877.45	#23 on, #36 off
08/16/07	SBVMWD	83.00	877.00	#23 on, #36 off
09/10/07	WMWD	81.22	878.78	#23 on, #36 off
09/14/07	C of R	81.00	879.00	
09/17/07	SBVMWD	81.00	879.00	#23 on, #36 off
10/08/07	WMWD	81.04	878.96	#23 off, #36 off
10/26/07	SBVMWD	81.30	878.70	#23 off, #36 off
11/19/07	SBVMWD	79.80	880.20	#23 off, #36 off
11/28/07	WMWD	81.89	878.11	#23 off, #36 off / Low
12/13/07	SBVMWD	77.00	883.00	#23 off, #36 off
12/21/07	C of R	78.00	882.00	
2008				
01/14/08	City of Riverside	76.41	882.96	
01/14/08	SBVMWD	75.60	884.40	
01/16/08	Watermaster	75.68	883.69	#23 off, #36 off
02/28/08	SBVMWD	74.10	885.90	
03/19/08	Watermaster	78.02	881.35	#23 off, #36 on
03/20/08	SBVMWD	78.30	881.70	
04/02/08	Watermaster	77.42	881.95	#23 off, #36 off
04/18/08	SBVMWD	79.30	880.70	
05/07/08	Watermaster	79.84	879.53	#23 off, #36 on
05/27/08	SBVMWD	80.00	880.00	
06/05/08	Watermaster	75.51	883.86	#23 off, #36 off
06/30/08	SBVMWD	84.00	876.00	
07/02/08	Watermaster	84.01	875.36	#23 off, #36 on
07/30/08	SBVMWD	85.02	874.98	
08/04/08	City of Riverside	85.70	873.67	
08/06/08	Watermaster	85.96	873.41	#23 on, #36 on
08/15/08	SBVMWD	86.02	873.98	
09/03/08	Watermaster	87.04	872.33	#23 on, #36 on
09/08/08	Watermaster	86.08	873.29	#23 on, #36 on / LOW
09/09/08	City of Riverside	87.11	872.26	
09/16/08	SBVMWD	87.20	872.80	
09/30/08	City of Riverside	86.71	872.66	

**Western San Bernardino Watermaster
Well Measurement Record for**

Johnson #1

State Well Number 1S/4W21Q03S

Basin: Colton-Rialto

Reference Point Elevation: 956.06

RP Elevation #2, top of MP: 960

RP Elevation #3, top of MP: 959.37

RP Elevation #4, top of 4" coupling in new box 954.5

RP #5 inside well lid 957.14 see note in comment box

Date	Obtained from	Ref. Pt. to Water	Water Surface Elevation	Remarks
10/01/08	City of Riverside	87.33	872.04	
10/01/08	Watermaster	87.33	872.04	#23 on, #36 on
10/24/08	SBVMWD	88.80	871.20	
11/06/08	Watermaster	88.50	870.87	#23 on, #36 on
11/24/08	SBVMWD	89.90	870.10	
12/04/08	Watermaster	87.94	871.43	#23 on, #36 off
12/16/08	SBVMWD	87.00	873.00	
2009				
01/08/09	Watermaster	86.59	872.78	#23 on, #36 off
01/14/09	SBVMWD	86.60	872.77	#23 on, #36 off
02/04/09	Watermaster	85.58	873.79	#23 on, #36 off
02/26/09	SBVMWD	82.50	876.87	#23 off, #36 off
03/03/09	City of Riverside	84.91	874.46	Static
03/04/09	Watermaster	85.08	874.29	#23 on, #36 off
03/23/09	SBVMWD	81.60	877.77	#23 off, #36 off
03/26/09	City of Riverside	86.49	872.88	Static; pulled transducer
03/27/09	City of Riverside	87.12	872.25	Static; set transducer
04/01/09	Watermaster	83.30	876.07	#23 off, #36 off
04/15/09	SBVMWD	84.70	874.67	#23 on, #36 off
05/06/09	Watermaster	84.87	874.50	#23 on, #36 off
05/14/09	SBVMWD	83.20	876.17	#23 on, #36 off
06/03/09	Watermaster	84.26	875.11	#23 on, #36 off
06/16/09	SBVMWD	84.00	875.37	#23 on, #36 off
07/01/09	Watermaster	87.39	871.98	#23 on, #36 on
07/20/09	SBVMWD	87.80	871.57	#23 on, #36 on
07/22/09	City of Riverside	86.74	872.63	Static
08/05/09	Watermaster	87.37	872.00	#23 on, #36 off
08/13/09	City of Riverside	88.19	871.18	Static
08/27/09	SBVMWD	88.45	870.92	#23 on, #36 off
09/02/09	Watermaster	88.93	870.44	#23 on, #36 on
09/10/09	City of Riverside	88.12	871.25	Static
09/18/09	City of Riverside	88.92	870.45	Static; #23 on, #36 off
09/27/09	SBVMWD	88.45	870.92	#23 on, #36 on
10/02/09	City of Riverside	89.56	869.81	Static; #23 on, #36 off
10/08/09	Watermaster	89.74	869.63	#23 on, #36 on
10/09/09	Watermaster	85.66	873.71	#23 off, #36 off (LOW)
10/22/09	SBVMWD	87.90	871.47	#23 on, #36 off
11/03/09	City of Riverside	88.38	870.99	Static; #23 on

**Western San Bernardino Watermaster
Well Measurement Record for**

Johnson #1

State Well Number 1S/4W21Q03S

Basin: Colton-Rialto

Reference Point Elevation: 956.06

RP Elevation #2, top of MP: 960

RP Elevation #3, top of MP: 959.37

RP Elevation #4, top of 4" coupling in new box 954.5

RP #5 inside well lid 957.14 see note in comment box

Date	Obtained from	Ref. Pt. to Water	Water Surface Elevation	Remarks
11/04/09	Watermaster	88.44	870.93	#23 on, #36 off
11/18/09	SBVMWD	88.60	870.77	#23 on, #36 off
12/02/09	City of Riverside	88.94	870.43	Static; #23 on
12/02/09	Watermaster	88.96	870.41	#23 on, #36 off
12/16/09	SBVMWD	88.10	871.27	#23 on, #36 off
2010				
01/06/10	Watermaster	88.88	870.49	#23 on, #36 off
01/06/10	City of Riverside	88.84	870.53	Static; #23 on
01/27/10	SBVMWD	85.65	873.72	#23 off, #36 off
02/03/10	Watermaster	87.42	871.95	#23 on, #36 off
02/04/10	City of Riverside	87.72	871.65	#23 pumping
02/26/10	SBVMWD	86.55	872.82	#23 on, #36 off
03/03/10	Watermaster	86.80	872.57	#23 on, #36 off
03/12/10	City of Riverside	87.60	871.77	
03/22/10	SBVMWD	87.15	872.22	#23 on, #36 off
04/07/10	Watermaster	82.87	876.50	#23 off #36 off
04/19/10	SBVMWD	86.30	873.07	#23 on, #36 off
05/05/10	Watermaster	86.67	872.70	#23 on, #36 off
05/18/10	City of Riverside	86.74	872.63	
05/24/10	SBVMWD	86.60	872.77	#23 on, #36 off
05/28/10	City of Riverside	81.98	872.52	
06/02/10	Watermaster	82.80	871.70	#23 on, #36 off
06/16/10	SBVMWD			Locked out
07/07/10	Watermaster	83.35	871.15	#23 on, #36 off
07/15/10	City of Riverside	82.47	872.03	
07/19/10	SBVMWD			Locked out
08/04/10	Watermaster	83.92	870.58	#23 on, #36 off
08/23/10	City of Riverside	83.26	871.24	
08/27/10	SBVMWD			Locked out
08/31/10	City of Riverside	83.43	871.07	
09/01/10	Watermaster	84.44	870.06	#23 on, #36 off
09/13/10	SBVMWD			Locked out
09/29/10	City of Riverside	83.96	870.54	
10/06/10	Watermaster	83.87	870.63	#23 on, #36 off
10/26/10	SBVMWD			Locked out
10/27/10	City of Riverside	83.19	871.31	corrected
11/03/10	Watermaster	84.86	869.64	#23 on, #36 off
11/17/10	SBVMWD			Locked out

**Western San Bernardino Watermaster
Well Measurement Record for**

Johnson #1

State Well Number 1S/4W21Q03S

Basin: Colton-Rialto

Reference Point Elevation: 956.06

RP Elevation #2, top of MP: 960

RP Elevation #3, top of MP: 959.37

RP Elevation #4, top of 4" coupling in new box 954.5

RP #5 inside well lid 957.14 see note in comment box

Date	Obtained from	Ref. Pt. to Water	Water Surface Elevation	Remarks
11/23/10	City of Riverside	83.64	870.86	
12/01/10	Watermaster	83.32	871.18	#23 off, #36 off LOW
12/08/10	City of Riverside	82.29	872.21	
12/13/10	SBVMWD		954.50	Locked out
2011				
01/05/11	Watermaster	81.89	872.61	Colton #23 off
01/06/11	City of Riverside	80.54	873.96	
02/02/11	Watermaster	83.58	870.92	Colton #23 off
02/07/11	City of Riverside	80.86	873.64	
03/02/11	Watermaster	82.37	872.13	Colton #23 pumping
03/17/11	City of Riverside	80.14	874.36	
04/05/11	City of Riverside	79.79	874.71	
04/06/11	Watermaster	82.28	872.22	Colton #23 pumping
05/04/11	Watermaster	82.51	871.99	Colton #23 pumping
05/07/11	City of Riverside	79.03	875.47	
06/01/11	Watermaster	79.61	874.89	Colton #23 pumping
06/05/11	City of Riverside	76.91	877.59	
07/06/11	Watermaster	80.68	873.82	Colton #23 pumping
07/13/11	City of Riverside	77.28	877.22	
08/14/11	City of Riverside	77.68	876.82	
08/18/11	Watermaster	81.27	873.23	Colton #23 pumping
09/07/11	Watermaster	81.71	872.79	Colton #23 pumping
09/18/11	City of Riverside	78.26	876.24	
10/05/11	Watermaster	81.12	873.38	Colton #23 off
10/26/11	City of Riverside	77.70	876.80	
10/30/11	City of Riverside	79.25	875.25	
11/02/11	Watermaster	81.04	873.46	Colton #23 off LOW
11/04/11	City of Riverside	78.67	875.83	
12/07/11	Watermaster	78.81	875.69	
2012				
01/04/12	City of Riverside	82.02	872.48	
01/04/12	Watermaster	78.57	875.93	
01/19/12	City of Riverside	77.09	877.41	
02/01/12	Watermaster	77.90	876.60	
02/18/12	City of Riverside	76.51	877.99	
03/07/12	Watermaster	77.52	876.98	
03/17/12	City of Riverside	75.80	878.70	

**Western San Bernardino Watermaster
Well Measurement Record for**

Johnson #1

State Well Number 1S/4W21Q03S

Basin: Colton-Rialto

Reference Point Elevation: 956.06

RP Elevation #2, top of MP: 960

RP Elevation #3, top of MP: 959.37

RP Elevation #4, top of 4" coupling in new box 954.5

RP #5 inside well lid 957.14 see note in comment box

Date	Obtained from	Ref. Pt. to Water	Water Surface Elevation	Remarks
04/04/12	Watermaster	76.67	877.83	
04/16/12	City of Riverside	75.61	878.89	
05/02/12	Watermaster	77.45	877.05	
05/08/12	City of Riverside	75.00	879.50	
06/06/12	Watermaster	81.11	873.39	Colton #23 pumping
06/17/12	City of Riverside	77.68	876.82	
07/11/12	Watermaster	82.67	871.83	Colton #23 pumping
07/14/12	City of Riverside	78.49	876.01	
08/01/12	Watermaster	83.22	871.28	Colton #23 pumping
08/24/12	City of Riverside	82.32	872.18	
09/05/12	Watermaster	84.19	870.31	Colton #23 pumping
09/16/12	City of Riverside	83.13	871.37	
10/10/12	Watermaster	85.76	868.74	Colton #23 pumping
10/14/12	City of Riverside	81.42	873.08	
11/14/12	Watermaster	81.90	872.60	
11/16/12	City of Riverside	80.80	873.70	
11/16/12	Watermaster	82.02	872.48	
12/12/12	Watermaster	82.60	871.90	Colton 23 off - LOW
12/13/12	City of Riverside	81.27	873.23	Colton 23 off
12/13/12	Watermaster	82.30	872.20	
12/14/12	City of Riverside	80.80	873.70	measured 10:10, Colton 23 off
12/14/12	Watermaster	81.83	872.67	
12/17/12	City of Riverside	80.61	873.89	measured 9:40, Colton 23 off
12/17/12	Watermaster	81.66	872.84	

2013

2013

01/09/13	Watermaster	81.03	873.47	#23 off, Sperry off
01/18/13	City of Riverside	82.18	872.32	Manual Water level measurement
02/13/13	Watermaster	83.27	871.23	#23 on, Sperry off
02/28/13	City of Riverside	82.10	872.40	Manual Water level measurement
03/13/13	Watermaster	82.72	871.78	#23 on, Sperry off
03/29/13	City of Riverside	78.89	875.61	Manual Water level measurement
04/10/13	Watermaster	80.61	873.89	#23 off, Sperry off
04/23/13	City of Riverside	85.4	869.10	Static
04/30/13	City of Riverside	82.96	871.54	Preliminary transducer data
05/08/13	Watermaster	82.24	872.26	#23 on, Sperry off
05/30/13	City of Riverside	79.91	874.59	Preliminary transducer data

**Western San Bernardino Watermaster
Well Measurement Record for**

Johnson #1

State Well Number 1S/4W21Q03S

Basin: Colton-Rialto

Reference Point Elevation: 956.06

RP Elevation #2, top of MP: 960

RP Elevation #3, top of MP: 959.37

RP Elevation #4, top of 4" coupling in new box 954.5

RP #5 inside well lid 957.14 see note in comment box

Date	Obtained from	Ref. Pt. to Water	Water Surface Elevation	Remarks
05/31/13	City of Riverside	79.91	874.59	Preliminary transducer data
06/05/13	City of Riverside	80.16	874.34	Preliminary transducer data
06/14/13	Watermaster	82.86	871.64	#23 on, Sperry off
07/10/13	Watermaster	84.53	869.97	#23 on, Sperry off
07/12/13	City of Riverside	80.34	874.16	Preliminary transducer data
08/14/13	Watermaster	85.02	869.48	#23 on, Sperry off
08/18/13	City of Riverside	81.15	873.35	Preliminary transducer data
08/19/13	City of Riverside	81.15	873.35	Preliminary transducer data
09/10/13	Watermaster	85.87	868.63	#23 on, Sperry off
09/22/13	City of Riverside	81.38	873.12	Preliminary transducer data
10/09/13	Watermaster	82.42	872.08	#23 off, Sperry off
10/09/13	City of Riverside	81.39	873.11	Preliminary transducer data
11/13/13	Watermaster	82.97	871.53	#23 off, Sperry off
11/19/13	City of Riverside	83.40	871.10	Static
11/27/13	City of Riverside	82.71	871.79	Manual Water level measurement, 2
11/27/13	Watermaster	84.17	870.33	#23 off, Sperry off
11/30/13	City of Riverside	81.87	872.63	Approved transducer data
12/02/13	City of Riverside	81.78	872.72	Manual level, 23 off / LOW
12/02/13	Watermaster	82.81	871.69	#23 off, Sperry off
12/11/13	Watermaster	81.79	872.71	#23 off, Sperry off

Western San Bernardino Watermaster Well Measurement Record for

Flume #2

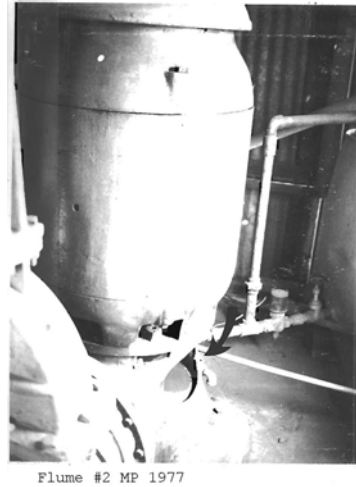
State Well Number 1S/4W29H01S

Water Level Records
1970-2013

Basin: Riverside North

Reference Point Elevation: 932.18

After January 2008, Reference Point Elevation: 932.45



Photo's clockwise from top left - Flume No. 2 Pump house 1977, Flume No. 2 Pump and MP 1977, Flume No.2 in fence and cage 2009, Flume No.2 pump 2009.

**Western San Bernardino Watermaster
Well Measurement Record for**

Flume #2

State Well Number 1S/4W29H01S

Basin: Riverside North

Reference Point Elevation: 932.18

Date	Obtained from	Ref. Pt. to Water	Water Surface Elevation	Remarks
1970				
11/23/70	City of Riverside	78.90	853.28	Pumping
01/28/70	City of Riverside	42.80	889.38	Static
1971				
01/04/71	City of Riverside	42.50	889.68	Static
01/11/71	City of Riverside	42.30	889.88	Static
01/18/71	City of Riverside	43.90	888.28	Static
01/25/71	City of Riverside	44.00	888.18	Static
02/01/71	City of Riverside	43.50	888.68	Static
04/12/71	City of Riverside	46.10	886.08	Static
04/19/71	City of Riverside	45.90	886.28	Static
05/10/71	City of Riverside	47.90	884.28	Static
05/17/71	City of Riverside	48.30	883.88	Static
05/24/71	City of Riverside	46.90	885.28	Static
06/21/71	City of Riverside	80.50	851.68	Pumping
06/28/71	City of Riverside	81.20	850.98	Pumping
07/06/71	City of Riverside	81.00	851.18	Pumping
07/12/71	City of Riverside	80.90	851.28	Pumping
07/20/71	City of Riverside	50.10	882.08	Static
07/26/71	City of Riverside	49.30	882.88	Static
08/09/71	City of Riverside	75.80	856.38	Pumping
08/16/71	City of Riverside	76.30	855.88	Pumping
08/23/71	City of Riverside	74.30	857.88	Pumping
09/06/71	City of Riverside	104.00	828.18	Pumping
09/14/71	City of Riverside	90.50	841.68	Pumping
09/20/71	City of Riverside	92.50	839.68	Pumping
09/27/71	City of Riverside	94.00	838.18	Pumping
09/30/71	City of Riverside	62.50	869.68	Static
10/04/71	City of Riverside	63.10	869.08	Static (Low)
10/11/71	City of Riverside	62.10	870.08	Static
10/18/71	City of Riverside	62.10	870.08	Static
11/01/71	City of Riverside	61.70	870.48	Static
11/09/71	City of Riverside	59.30	872.88	Static
11/15/71	City of Riverside	59.50	872.68	Static
11/22/71	City of Riverside	57.60	874.58	Static
12/02/71	City of Riverside	47.30	884.88	Static
12/06/71	City of Riverside	57.30	874.88	Static
12/13/71	City of Riverside	57.60	874.58	Static

**Western San Bernardino Watermaster
Well Measurement Record for**

Flume #2

State Well Number 1S/4W29H01S

Basin: Riverside North

Reference Point Elevation: 932.18

Date	Obtained from	Ref. Pt. to Water	Water Surface Elevation	Remarks
12/20/71	City of Riverside	56.80	875.38	Static
12/27/71	City of Riverside	58.00	874.18	Static
1972				
01/03/72	City of Riverside	54.40	877.78	Static
01/10/72	City of Riverside	55.20	876.98	Static
01/17/72	City of Riverside	54.10	878.08	Static
01/20/72	City of Riverside	53.90	878.28	Idle 53.9 Pump 83.5 Edison Te
01/24/72	City of Riverside	54.00	878.18	Static
02/01/72	City of Riverside	53.50	878.68	Static
02/07/72	City of Riverside	53.90	878.28	Static
02/14/72	City of Riverside	54.20	877.98	Static
02/21/72	City of Riverside	87.40	844.78	Pumping
02/28/72	City of Riverside	88.00	844.18	Pumping
03/06/72	City of Riverside	58.40	873.78	Static
03/13/72	City of Riverside	58.00	874.18	Static
03/20/72	City of Riverside	59.40	872.78	Static
03/27/72	City of Riverside	90.60	841.58	Pumping
04/01/72	City of Riverside	60.40	871.78	Static
04/10/72	City of Riverside	89.60	842.58	Pumping
04/17/72	City of Riverside	93.20	838.98	Pumping
04/24/72	City of Riverside	94.50	837.68	Pumping
05/01/72	City of Riverside	94.40	837.78	Pumping
05/08/72	City of Riverside	63.20	868.98	Static
05/15/72	City of Riverside	64.90	867.28	Static
05/22/72	City of Riverside	94.30	837.88	Pumping
05/29/72	City of Riverside	95.10	837.08	Pumping
06/01/72	City of Riverside	94.60	837.58	Pumping
06/05/72	City of Riverside	93.40	838.78	Pumping
06/12/72	City of Riverside	93.40	838.78	Pumping
06/19/72	City of Riverside	110.40	821.78	Pumping
06/26/72	City of Riverside	108.60	823.58	Pumping
07/01/72	City of Riverside	104.80	827.38	Pumping
07/10/72	City of Riverside	105.60	826.58	Pumping
07/17/72	City of Riverside	106.20	825.98	Pumping
07/24/72	City of Riverside	106.40	825.78	Pumping
07/31/72	City of Riverside	105.60	826.58	Pumping
08/26/72	City of Riverside	106.10	826.08	Pumping
09/01/72	City of Riverside	104.70	827.48	Pumping

**Western San Bernardino Watermaster
Well Measurement Record for**

Flume #2

State Well Number 1S/4W29H01S

Basin: Riverside North

Reference Point Elevation: 932.18

Date	Obtained from	Ref. Pt. to Water	Water Surface Elevation	Remarks
09/11/72	City of Riverside	105.90	826.28	Pumping
09/18/72	City of Riverside	105.20	826.98	Pumping
09/25/72	City of Riverside	104.00	828.18	Pumping
10/16/72	City of Riverside	109.60	822.58	Pumping
10/24/72	City of Riverside	107.80	824.38	Pumping
10/30/72	City of Riverside	107.30	824.88	Pumping
11/06/72	City of Riverside	107.10	825.08	Pumping
11/09/72	USGS	111.59	820.59	
11/14/72	City of Riverside	107.60	824.58	Pumping
11/20/72	City of Riverside	107.20	824.98	Pumping
11/27/72	City of Riverside	71.60	860.58	Static (Low)
11/28/72	USGS	103.38	828.80	
12/04/72	City of Riverside	105.80	826.38	Pumping
12/18/72	City of Riverside	66.00	866.18	Static
12/26/72	City of Riverside	103.60	828.58	Pumping
12/27/72	USGS	97.60	834.58	
1973				
01/02/73	City of Riverside	107.90	824.28	Pumping
01/08/73	City of Riverside	98.00	834.18	Pumping
01/22/73	City of Riverside	98.70	833.48	Pumping
01/29/73	City of Riverside	62.70	869.48	Static
02/05/73	City of Riverside	98.90	833.28	Pumping 2-5 USGS 92.73=839.45
02/20/73	City of Riverside	96.80	835.38	Pumping
02/26/73	City of Riverside	88.70	843.48	Pumping 2-28 USGS 88.17=844.0
03/05/73	City of Riverside	88.50	843.68	Pumping
03/12/73	City of Riverside	88.90	843.28	Pumping
03/21/73	City of Riverside	81.30	850.88	Pumping TDS 440
04/01/73	City of Riverside	83.40	848.78	Pumping Apr. 2 USGS 83.84=848
04/16/73	City of Riverside	50.50	881.68	Static
04/23/73	City of Riverside	50.80	881.38	Static Apr. 26 USGS 81.18=851
05/08/73	City of Riverside	85.30	846.88	Pumping
05/27/73	City of Riverside	85.50	846.68	Pumping
05/30/73	USGS	83.86	848.32	Pumping
06/11/73	City of Riverside	84.60	847.58	Pumping
06/18/73	City of Riverside	85.10	847.08	Pumping
06/26/73	City of Riverside	87.60	844.58	Pumping
07/01/73	City of Riverside	55.30	876.88	Static
07/03/73	USGS	54.99	877.19	Static

**Western San Bernardino Watermaster
Well Measurement Record for**

Flume #2

State Well Number 1S/4W29H01S

Basin: Riverside North

Reference Point Elevation: 932.18

Date	Obtained from	Ref. Pt. to Water	Water Surface Elevation	Remarks
07/09/73	City of Riverside	87.20	844.98	Pumping
07/16/73	City of Riverside	57.80	874.38	Static
07/23/73	City of Riverside	86.40	845.78	Pumping
08/06/73	City of Riverside	85.50	846.68	Pumping
08/13/73	City of Riverside	84.10	848.08	Pumping
08/20/73	City of Riverside	84.50	847.68	Pumping
08/28/73	USGS	54.75	877.43	Static
09/01/73	City of Riverside	81.20	850.98	Static
09/10/73	City of Riverside	89.30	842.88	Static
09/16/73	City of Riverside	89.00	843.18	Static
10/01/73	City of Riverside	90.10	842.08	Static
10/01/73	USGS	60.54	871.64	Static
10/08/73	City of Riverside	91.10	841.08	Static
10/16/73	City of Riverside	94.60	837.58	Static
10/23/73	City of Riverside	95.30	836.88	Static
10/30/73	City of Riverside	94.50	837.68	Static
11/03/73	City of Riverside	94.60	837.58	Static
11/06/73	City of Riverside	94.10	838.08	Static
11/13/73	City of Riverside	94.30	837.88	Static
11/20/73	City of Riverside	62.70	869.48	Static (Low)
11/27/73	City of Riverside	61.50	870.68	Static
12/01/73	City of Riverside	61.20	870.98	Static
12/04/73	City of Riverside	60.90	871.28	Static
12/05/73	USGS	60.65	871.53	Static
12/11/73	City of Riverside	60.50	871.68	Static
12/18/73	City of Riverside	60.50	871.68	Static
12/26/73	City of Riverside	59.10	873.08	Static
1974				
01/01/74	City of Riverside	58.30	873.88	Static
01/01/74	USGS	54.29	877.89	Static
01/08/74	City of Riverside	55.40	876.78	Static
01/08/74	USGS	55.01	877.17	Static
01/15/74	City of Riverside	53.10	879.08	Static
01/22/74	City of Riverside	52.70	879.48	Static
01/29/74	City of Riverside	52.40	879.78	Static
02/01/74	City of Riverside	52.10	880.08	Static
02/05/74	City of Riverside	53.00	879.18	Static
02/06/74	USGS	52.65	879.53	Static

**Western San Bernardino Watermaster
Well Measurement Record for**

Flume #2

State Well Number 1S/4W29H01S

Basin: Riverside North

Reference Point Elevation: 932.18

Date	Obtained from	Ref. Pt. to Water	Water Surface Elevation	Remarks
02/12/74	City of Riverside	53.10	879.08	Static
02/26/74	City of Riverside	87.40	844.78	Pumping
03/05/74	City of Riverside	55.10	877.08	Idle
03/12/74	City of Riverside	56.20	875.98	Idle
03/19/74	City of Riverside	54.60	877.58	Idle
03/26/74	City of Riverside	51.30	880.88	Idle
04/02/74	City of Riverside	86.00	846.18	Pumping
04/04/74	USGS	-	-	Pumping
04/06/74	City of Riverside	85.50	846.68	Pumping
04/09/74	City of Riverside	85.50	846.68	Pumping
04/17/74	City of Riverside	84.80	847.38	Pumping
04/23/74	City of Riverside	90.20	841.98	Pumping
04/30/74	City of Riverside	90.80	841.38	Pumping
05/02/74	USGS	57.87	874.31	Static
05/07/74	City of Riverside	57.60	874.58	Static
05/14/74	City of Riverside	56.30	875.88	Static
05/21/74	City of Riverside	56.40	875.78	Static
05/28/74	City of Riverside	90.80	841.38	Pumping
06/05/74	City of Riverside	91.60	840.58	Pumping
06/11/74	City of Riverside	92.40	839.78	Pumping
06/19/74	City of Riverside	59.10	873.08	Static
06/25/74	City of Riverside	60.40	871.78	Static
06/27/74	USGS	59.60	872.58	Static
07/09/74	City of Riverside	60.90	871.28	Static
07/17/74	City of Riverside	62.10	870.08	Static
07/24/74	City of Riverside	62.20	869.98	Static
07/25/74	SBVMWD	63.10	869.08	Static
07/30/74	City of Riverside	62.40	869.78	Static
08/09/74	City of Riverside	63.50	868.68	Static
08/13/74	City of Riverside	63.40	868.78	Static
08/20/74	City of Riverside	63.40	868.78	Static
08/22/74	SBVMWD	63.96	868.22	Static
08/27/74	City of Riverside	64.50	867.68	Static
09/01/74	City of Riverside	64.50	867.68	Static
09/03/74	City of Riverside	65.10	867.08	Static
09/10/74	City of Riverside	65.40	866.78	Static
09/24/74	City of Riverside	98.80	833.38	Pumping
10/01/74	City of Riverside	99.80	832.38	Pumping
10/08/74	City of Riverside	101.40	830.78	Pumping

**Western San Bernardino Watermaster
Well Measurement Record for**

Flume #2

State Well Number 1S/4W29H01S

Basin: Riverside North

Reference Point Elevation: 932.18

Date	Obtained from	Ref. Pt. to Water	Water Surface Elevation	Remarks
10/16/74	City of Riverside	102.10	830.08	Pumping
10/22/74	City of Riverside	101.90	830.28	Pumping
10/24/74	SBVMWD	64.27	867.91	Static
10/31/74	City of Riverside	68.40	863.78	Static (Low)
11/05/74	City of Riverside	67.40	864.78	Static
11/12/74	City of Riverside	66.60	865.58	Static
11/20/74	City of Riverside	65.80	866.38	Static
11/22/74	SBVMWD	65.40	866.78	Static
11/26/74	City of Riverside	66.10	866.08	Static
12/01/74	City of Riverside	65.30	866.88	Static
12/03/74	City of Riverside	65.10	867.08	Static
12/10/74	City of Riverside	64.20	867.98	Static
12/17/74	City of Riverside	60.90	871.28	Static
12/24/74	City of Riverside	61.10	871.08	Static
12/30/74	City of Riverside	60.80	871.38	Static
1975				
01/07/75	City of Riverside	59.10	873.08	Static
01/14/75	City of Riverside	58.90	873.28	Static
01/16/75	SBVMWD	60.17	872.01	Static
01/21/75	City of Riverside	91.40	840.78	Pumping
01/28/75	City of Riverside	92.90	839.28	Pumping
02/03/75	City of Riverside	93.90	838.28	Pumping
02/11/75	City of Riverside	57.80	874.38	Static
02/18/75	City of Riverside	56.50	875.68	Static
02/27/75	City of Riverside	80.20	851.98	Pumping?
03/11/75	City of Riverside	55.20	876.98	Static
03/12/75	SBVMWD	59.63	872.55	Static
03/18/75	City of Riverside	53.80	878.38	Static
03/25/75	City of Riverside	53.90	878.28	Static
04/01/75	City of Riverside	54.10	878.08	Static
04/08/75	City of Riverside	54.30	877.88	Static
04/10/75	SBVMWD	57.86	874.32	Static
04/16/75	City of Riverside	52.40	879.78	Static
04/23/75	City of Riverside	53.60	878.58	Static
04/30/75	City of Riverside	53.30	878.88	Static
05/06/75	City of Riverside	86.10	846.08	Pumping
05/13/75	City of Riverside	87.10	845.08	Pumping
05/22/75	City of Riverside	88.00	844.18	Pumping

**Western San Bernardino Watermaster
Well Measurement Record for**

Flume #2

State Well Number 1S/4W29H01S

Basin: Riverside North

Reference Point Elevation: 932.18

Date	Obtained from	Ref. Pt. to Water	Water Surface Elevation	Remarks
05/27/75	City of Riverside	55.80	876.38	Pumping Nearby
06/03/75	City of Riverside	88.40	843.78	Pumping
06/10/75	City of Riverside	88.10	844.08	Pumping
06/17/75	City of Riverside	89.50	842.68	Pumping
06/24/75	City of Riverside	57.50	874.68	Static
06/25/75	City of Riverside	57.50	874.68	Static
07/01/75	City of Riverside	57.80	874.38	Static
07/09/75	City of Riverside	58.30	873.88	Static
07/10/75	SBVMWD	64.28	867.90	Static
07/15/75	City of Riverside	91.80	840.38	Pumping
07/22/75	City of Riverside	61.90	870.28	Static
07/29/75	City of Riverside	63.70	868.48	Static
08/04/75	City of Riverside	94.60	837.58	Pumping
08/10/75	City of Riverside	64.50	867.68	Pumping Nearby
08/14/75	SBVMWD	64.60	867.58	Pumping
08/17/75	City of Riverside	64.60	867.58	Pumping Nearby
09/01/75	City of Riverside	95.60	836.58	Pumping
09/10/75	City of Riverside	65.80	866.38	Pumping Nearby
09/12/75	SBVMWD	61.05	871.13	Static
09/16/75	City of Riverside	65.50	866.68	Pumping Nearby
09/23/75	City of Riverside	65.20	866.98	Pumping Nearby
09/30/75	City of Riverside	65.30	866.88	Pumping
10/01/75	City of Riverside	65.20	866.98	Pumping Nearby
10/07/75	City of Riverside	64.90	867.28	Pumping Nearby
10/10/75	SBVMWD	58.86	873.32	Static
10/15/75	City of Riverside	65.40	866.78	Pumping Nearby
10/21/75	City of Riverside	66.30	865.88	Pumping Nearby
10/28/75	City of Riverside	66.50	865.68	Pumping Nearby
11/04/75	City of Riverside	66.90	865.28	Pumping Nearby
11/12/75	City of Riverside	70.40	861.78	Pumping Nearby
11/19/75	City of Riverside	66.70	865.48	Static (Low)
11/28/75	City of Riverside	66.20	865.98	Static
12/02/75	City of Riverside	67.00	865.18	Pumping Nearby
12/09/75	City of Riverside	68.10	864.08	Pumping Nearby
12/10/75	SBVMWD	69.44	862.74	Pumping Nearby
12/23/75	City of Riverside	68.30	863.88	Pumping Nearby
12/30/75	City of Riverside	67.90	864.28	Pumping Nearby

1976

**Western San Bernardino Watermaster
Well Measurement Record for**

Flume #2

State Well Number 1S/4W29H01S

Basin: Riverside North

Reference Point Elevation: 932.18

Date	Obtained from	Ref. Pt. to Water	Water Surface Elevation	Remarks
01/07/76	City of Riverside	67.30	864.88	Static
01/13/76	City of Riverside	69.40	862.78	Static
01/15/76	SBVMWD	64.87	867.31	Static
01/20/76	City of Riverside	68.30	863.88	Static
01/27/76	City of Riverside	65.20	866.98	Static
02/04/76	City of Riverside	64.90	867.28	Static
02/11/76	City of Riverside	57.40	874.78	Static
02/12/76	SBVMWD	57.40	874.78	Static
02/17/76	City of Riverside	60.60	871.58	Static
02/24/76	City of Riverside	57.00	875.18	Static
03/02/76	City of Riverside	56.50	875.68	Static
03/09/76	City of Riverside	56.10	876.08	Static
03/12/76	SBVMWD	56.29	875.89	Static
03/17/76	City of Riverside	57.10	875.08	Static
03/23/76	City of Riverside	58.00	874.18	Static
04/01/76	City of Riverside	60.00	872.18	Static
04/06/76	City of Riverside	61.60	870.58	Static
04/13/76	City of Riverside	63.30	868.88	Static
04/15/76	SBVMWD	62.74	869.44	Static
04/21/76	City of Riverside	63.90	868.28	Static
04/27/76	City of Riverside	62.80	869.38	Static
05/04/76	City of Riverside	66.90	865.28	Static
05/11/76	City of Riverside	64.60	867.58	Static
05/12/76	SBVMWD	70.31	861.87	Static
05/18/76	City of Riverside	67.40	864.78	Static
05/26/76	City of Riverside	68.70	863.48	Static
06/01/76	City of Riverside	69.60	862.58	Static
06/09/76	City of Riverside	70.50	861.68	Static
06/11/76	SBVMWD	70.77	861.41	Static
06/15/76	City of Riverside	71.20	860.98	Static
06/22/76	City of Riverside	78.30	853.88	Static
06/30/76	City of Riverside	79.10	853.08	Static (Low)
07/13/76	City of Riverside	78.20	853.98	Static
07/15/76	SBVMWD	76.18	856.00	Static
07/20/76	City of Riverside	75.70	856.48	Static
07/27/76	City of Riverside	75.60	856.58	Static
08/01/76	City of Riverside	75.60	856.58	Static
08/10/76	City of Riverside	75.40	856.78	Static
08/13/76	SBVMWD	78.29	853.89	Static

**Western San Bernardino Watermaster
Well Measurement Record for**

Flume #2

State Well Number 1S/4W29H01S

Basin: Riverside North

Reference Point Elevation: 932.18

Date	Obtained from	Ref. Pt. to Water	Water Surface Elevation	Remarks
08/17/76	City of Riverside	76.30	855.88	Static
08/17/76	City of Riverside	75.90	856.28	Static
08/31/76	City of Riverside	76.00	856.18	Static
09/08/76	City of Riverside	75.90	856.28	Static
09/10/76	SBVMWD	71.54	860.64	Static
09/14/76	City of Riverside	74.10	858.08	Static
09/21/76	City of Riverside	71.90	860.28	Static
09/28/76	City of Riverside	71.40	860.78	Static
10/06/76	City of Riverside	73.90	858.28	Static
10/12/76	City of Riverside	73.20	858.98	Static
10/13/76	SBVMWD	74.33	857.85	Static
10/17/76	City of Riverside	70.20	861.98	Static
10/26/76	City of Riverside	71.40	860.78	Static
11/01/76	City of Riverside	71.70	860.48	Static
11/10/76	City of Riverside	72.80	859.38	Static
11/16/76	City of Riverside	73.10	859.08	Static
11/17/76	SBVMWD	73.92	858.26	Static
11/23/76	City of Riverside	73.90	858.28	Static
12/01/76	City of Riverside	74.40	857.78	Static
12/07/76	City of Riverside	74.10	858.08	Static
12/14/76	City of Riverside	74.20	857.98	Static
12/16/76	SBVMWD	75.10	857.08	Static
12/21/76	City of Riverside	74.80	857.38	Static
1977				
01/01/77	City of Riverside	74.70	857.48	Static
01/04/77	City of Riverside	73.60	858.58	Static
01/12/77	City of Riverside	72.80	859.38	Static
01/17/77	SBVMWD	72.50	859.68	Static
01/18/77	City of Riverside	71.90	860.28	Static
01/25/77	City of Riverside	72.10	860.08	Static
02/01/77	City of Riverside	71.80	860.38	Static
02/08/77	City of Riverside	105.20	826.98	Well Pumping
02/10/77	SBVMWD	102.70	829.48	Well Pumping
02/15/77	City of Riverside	108.20	823.98	Well Pumping
02/22/77	City of Riverside	109.40	822.78	Well Pumping
03/01/77	City of Riverside	75.60	856.58	Static
03/08/77	City of Riverside	74.20	857.98	Static
03/10/77	SBVMWD	74.80	857.38	Static

**Western San Bernardino Watermaster
Well Measurement Record for**

Flume #2

State Well Number 1S/4W29H01S

Basin: Riverside North

Reference Point Elevation: 932.18

Date	Obtained from	Ref. Pt. to Water	Water Surface Elevation	Remarks
03/15/77	City of Riverside	75.00	857.18	Static
03/22/77	City of Riverside	76.50	855.68	Static
03/29/77	City of Riverside	77.00	855.18	Static
04/01/77	City of Riverside	76.30	855.88	Static
04/05/77	City of Riverside	72.80	859.38	Static
04/12/77	City of Riverside	72.40	859.78	Static
04/13/77	SBVMWD	74.00	858.18	Static
04/19/77	City of Riverside	72.80	859.38	Static
04/26/77	City of Riverside	72.40	859.78	Static
05/01/77	City of Riverside	72.80	859.38	Static #3 pumping
05/05/77	City of Riverside	106.30	825.88	Well Pumping
05/10/77	City of Riverside	76.30	855.88	Static
05/11/77	SBVMWD	76.88	855.30	Static
05/17/77	City of Riverside	66.70	865.48	Static
05/24/77	City of Riverside	73.30	858.88	Static
06/02/77	City of Riverside	75.50	856.68	Well Pumping (?)
06/07/77	City of Riverside	107.80	824.38	Well Pumping
06/08/77	SBVMWD	122.00	810.18	Well Pumping
06/14/77	City of Riverside	108.90	823.28	Well Pumping
06/21/77	City of Riverside	107.80	824.38	Well Pumping
06/28/77	City of Riverside	109.40	822.78	Well Pumping
07/05/77	City of Riverside	110.00	822.18	Well Pumping
07/07/77	SBVMWD	121.96	810.22	Well Pumping
07/12/77	City of Riverside	76.60	855.58	Static
07/19/77	City of Riverside	76.70	855.48	Static
07/19/77	WMWD	77.10	855.08	Static
07/26/77	City of Riverside	78.30	853.88	Static
08/01/77	City of Riverside	79.00	853.18	Static
08/02/77	City of Riverside	79.20	852.98	Static
08/08/77	City of Riverside	80.00	852.18	Static
08/09/77	WMWD	79.80	852.38	Pump off one hour
08/16/77	City of Riverside	80.60	851.58	Static Meeks & Mill on
08/22/77	WMWD	76.70	855.48	Static
08/23/77	City of Riverside	76.80	855.38	Static
08/25/77	SBVMWD	75.69	856.49	Static
08/31/77	City of Riverside	76.80	855.38	Static Mill on
09/01/77	City of Riverside	76.80	855.38	Static
09/13/77	City of Riverside	110.40	821.78	Well Pumping
09/20/77	City of Riverside	112.30	819.88	Well Pumping

**Western San Bernardino Watermaster
Well Measurement Record for**

Flume #2

State Well Number 1S/4W29H01S

Basin: Riverside North

Reference Point Elevation: 932.18

Date	Obtained from	Ref. Pt. to Water	Water Surface Elevation	Remarks
09/21/77	SBVMWD	111.10	821.08	Well Pumping
09/27/77	City of Riverside	111.00	821.18	Well Pumping
10/01/77	City of Riverside	111.20	820.98	Well Pumping
10/05/77	City of Riverside	111.90	820.28	Well Pumping
10/11/77	City of Riverside	79.70	852.48	Static
10/11/77	SBVMWD	97.79	834.39	Static (?)
10/20/77	City of Riverside	80.60	851.58	Static #4 on
10/25/77	City of Riverside	80.20	851.98	Static #4 on
11/02/77	City of Riverside	81.20	850.98	Static #4 on
11/08/77	City of Riverside	80.90	851.28	Static #4 on
11/11/77	WMWD	82.10	850.08	Static #4 on
11/15/77	City of Riverside	83.20	848.98	Static #4 on
11/15/77	SBVMWD	82.40	849.78	Static, pumping nearby
11/22/77	City of Riverside	83.80	848.38	Static #4 on
12/01/77	City of Riverside	82.10	850.08	Static #4 on
12/06/77	City of Riverside	82.80	849.38	Static #4 on
12/13/77	City of Riverside	83.00	849.18	Static #4 on
12/14/77	SBVMWD	83.34	848.84	Static, pumping nearby
12/20/77	City of Riverside	83.80	848.38	Static #4 on
12/27/77	City of Riverside	85.00	847.18	Static (Low)
1978				
01/01/78	City of Riverside	85.00	847.18	Static
01/10/78	City of Riverside	76.50	855.68	Static
01/14/78	SBVMWD	76.98	855.20	Static
01/17/78	City of Riverside	72.30	859.88	Static
01/24/78	City of Riverside	71.80	860.38	Static
01/31/78	City of Riverside	71.80	860.38	Static
02/07/78	City of Riverside	70.10	862.08	Static
02/14/78	City of Riverside	68.20	863.98	Static
02/16/78	SBVMWD	68.20	863.98	Static
02/17/78	WMWD	67.30	864.88	Static
02/21/78	City of Riverside	67.80	864.38	Static
02/28/78	City of Riverside	66.90	865.28	Static
03/14/78	City of Riverside	51.10	881.08	Static
03/16/78	SBVMWD	48.35	883.83	Static
03/21/78	City of Riverside	44.20	887.98	Static
03/29/78	City of Riverside	41.30	890.88	Static
04/05/78	City of Riverside	37.60	894.58	Static

**Western San Bernardino Watermaster
Well Measurement Record for**

Flume #2

State Well Number 1S/4W29H01S

Basin: Riverside North

Reference Point Elevation: 932.18

Date	Obtained from	Ref. Pt. to Water	Water Surface Elevation	Remarks
04/11/78	City of Riverside	35.90	896.28	Static
04/11/78	SBVMWD	41.90	890.28	Static
04/18/78	City of Riverside	66.80	865.38	Pumping
04/25/78	City of Riverside	34.20	897.98	Static
04/27/78	WMWD	32.00	900.18	Static
05/10/78	SBVMWD	30.10	902.08	Static
05/10/78	City of Riverside	29.80	902.38	Static
05/17/78	City of Riverside	29.80	902.38	Static
05/25/78	City of Riverside	28.70	903.48	Static
06/07/78	City of Riverside	28.80	903.38	Static
06/13/78	City of Riverside	29.20	902.98	Static
06/13/78	WMWD	29.00	903.18	Static
06/14/78	SBVMWD	29.10	903.08	Static
06/20/78	City of Riverside	28.20	903.98	Static
06/28/78	City of Riverside	28.10	904.08	Static
07/04/78	City of Riverside	29.20	902.98	Static
07/11/78	SBVMWD	31.10	901.08	Static
07/11/78	City of Riverside	30.40	901.78	Static
08/01/78	City of Riverside	31.60	900.58	Static
08/02/78	WMWD	31.40	900.78	Static
08/08/78	City of Riverside	31.00	901.18	Static
08/09/78	SBVMWD	32.15	900.03	Static
08/15/78	City of Riverside	30.90	901.28	Static
08/22/78	City of Riverside	31.00	901.18	Static
08/29/78	City of Riverside	31.10	901.08	Static
09/04/78	City of Riverside	31.40	900.78	Static
09/12/78	City of Riverside	33.40	898.78	Static
09/13/78	SBVMWD	33.89	898.29	Static
09/13/78	WMWD	33.10	899.08	Static
09/20/78	City of Riverside	34.10	898.08	Static
09/26/78	City of Riverside	34.90	897.28	Static
10/01/78	City of Riverside	35.00	897.18	Static
10/09/78	City of Riverside	36.50	895.68	Static
10/11/78	SBVMWD	36.62	895.56	Static
10/17/78	City of Riverside	36.70	895.48	Static
10/24/78	City of Riverside	38.10	894.08	Static
10/26/78	WMWD	38.00	894.18	Static
11/06/78	City of Riverside	39.60	892.58	Static
11/14/78	City of Riverside	39.80	892.38	Static

**Western San Bernardino Watermaster
Well Measurement Record for**

Flume #2

State Well Number 1S/4W29H01S

Basin: Riverside North

Reference Point Elevation: 932.18

Date	Obtained from	Ref. Pt. to Water	Water Surface Elevation	Remarks
11/15/78	SBVMWD	40.55	891.63	Static (Low)
11/21/78	City of Riverside	36.50	895.68	Static
11/28/78	City of Riverside	38.50	893.68	Static
12/05/78	City of Riverside	37.60	894.58	Static
12/13/78	SBVMWD	37.70	894.48	Static
12/19/78	City of Riverside	32.40	899.78	Static
12/27/78	City of Riverside	32.20	899.98	Static
1979				
01/02/79	City of Riverside	32.00	900.18	Static
01/09/79	City of Riverside	32.30	899.88	Static
01/16/79	City of Riverside	32.00	900.18	Static
01/17/79	SBVMWD	35.25	896.93	Reading Error?
01/30/79	City of Riverside	33.40	898.78	Static
02/05/79	WMWD	33.00	899.18	Static
02/06/79	City of Riverside	33.30	898.88	Static
02/14/79	City of Riverside	32.30	899.88	Static
02/15/79	SBVMWD	33.00	899.18	Static
02/20/79	City of Riverside	33.00	899.18	Static
03/01/79	City of Riverside	31.60	900.58	Static
03/07/79	WMWD	30.90	901.28	Static
03/07/79	City of Riverside	31.00	901.18	Static
03/14/79	City of Riverside	29.80	902.38	Static
03/14/79	SBVMWD	32.25	899.93	Reading Error?
03/20/79	City of Riverside	29.60	902.58	Static
03/27/79	City of Riverside	28.90	903.28	Static
04/03/79	City of Riverside	28.60	903.58	Static
04/10/79	City of Riverside	27.60	904.58	Static
04/11/79	SBVMWD	33.00	899.18	Reading Error?
04/18/79	City of Riverside	26.50	905.68	Static
04/25/79	City of Riverside	25.90	906.28	Static
05/03/79	City of Riverside	24.80	907.38	Static
05/16/79	SBVMWD	28.70	903.48	Reading Error?
05/22/79	WMWD	26.00	906.18	Static
05/22/79	City of Riverside	25.20	906.98	Static
05/29/79	City of Riverside	26.40	905.78	Static
06/01/79	City of Riverside	26.40	905.78	Static
06/05/79	City of Riverside	27.40	904.78	Static
06/11/79	SBVMWD	30.25	901.93	Reading Error?

**Western San Bernardino Watermaster
Well Measurement Record for**

Flume #2

State Well Number 1S/4W29H01S

Basin: Riverside North

Reference Point Elevation: 932.18

Date	Obtained from	Ref. Pt. to Water	Water Surface Elevation	Remarks
06/12/79	City of Riverside	28.20	903.98	Static
06/19/79	City of Riverside	29.30	902.88	Static
06/26/79	City of Riverside	29.80	902.38	Static
07/03/79	City of Riverside	30.80	901.38	Static
07/10/79	City of Riverside	31.10	901.08	Static
07/11/79	SBVMWD	32.15	900.03	Static
08/01/79	City of Riverside	31.20	900.98	Static
08/08/79	SBVMWD	32.35	899.83	Static
08/14/79	City of Riverside	30.80	901.38	Static
08/21/79	WMWD	35.00	897.18	Static
08/28/79	City of Riverside	37.10	895.08	Static
09/05/79	City of Riverside	36.10	896.08	Static
09/13/79	SBVMWD	38.80	893.38	Static
10/01/79	City of Riverside	32.00	900.18	Reading Error?
10/11/79	SBVMWD	41.70	890.48	Low
10/16/79	City of Riverside	39.30	892.88	Static
10/23/79	City of Riverside	38.10	894.08	Static
10/30/79	City of Riverside	38.30	893.88	Static
11/06/79	City of Riverside	38.60	893.58	Static
11/13/79	City of Riverside	39.70	892.48	Static
11/15/79	SBVMWD	40.30	891.88	Static
11/16/79	WMWD	40.00	892.18	Static
11/21/79	City of Riverside	40.70	891.48	Static
11/27/79	City of Riverside	40.60	891.58	Static
12/17/79	SBVMWD	40.75	891.43	Static
1980				
01/18/80	WMWD	41.00	891.18	Static
01/21/80	SBVMWD	41.18	891.00	Static
02/04/80	WMWD	38.20	893.98	Static
02/14/80	SBVMWD	38.73	893.45	Static
03/04/80	City of Riverside	26.00	906.18	Static
03/14/80	SBVMWD	21.30	910.88	Static
04/04/80	City of Riverside	22.00	910.18	Static
04/08/80	WMWD	22.00	910.18	Static
04/16/80	SBVMWD	22.20	909.98	Static
05/05/80	City of Riverside	22.00	910.18	Static
05/16/80	SBVMWD	20.70	911.48	Static
05/21/80	City of Riverside	22.20	909.98	Static

**Western San Bernardino Watermaster
Well Measurement Record for**

Flume #2

State Well Number 1S/4W29H01S

Basin: Riverside North

Reference Point Elevation: 932.18

Date	Obtained from	Ref. Pt. to Water	Water Surface Elevation	Remarks
06/12/80	SBVMWD	21.93	910.25	Static
07/22/80	SBVMWD	21.87	910.31	Static
08/13/80	SBVMWD	21.84	910.34	Static
08/13/80	WMWD	21.40	910.78	Static
09/08/80	WMWD	22.40	909.78	Static
09/16/80	City of Riverside	23.20	908.98	Static
09/17/80	SBVMWD	22.89	909.29	Static
09/30/80	City of Riverside	23.00	909.18	Static
10/01/80	City of Riverside	23.00	909.18	Static
10/15/80	City of Riverside	23.50	908.68	Static
10/21/80	City of Riverside	23.50	908.68	Static
10/23/80	SBVMWD	23.59	908.59	Static
10/28/80	City of Riverside	23.80	908.38	Static
11/03/80	WMWD	23.70	908.48	Static
11/04/80	City of Riverside	24.50	907.68	Static
11/01/44	City of Riverside	24.70	907.48	Low
11/18/80	City of Riverside	23.00	909.18	Static
11/26/80	SBVMWD	23.73	908.45	Static
12/18/80	SBVMWD	23.37	908.81	Static
12/23/80	WMWD	22.70	909.48	Static

1981

01/06/81	City of Riverside	21.80	910.38	Static
01/15/81	SB	21.67	910.51	Static
01/15/81	City of Riverside	21.20	910.98	Static
01/20/81	City of Riverside	21.60	910.58	Static
01/27/81	City of Riverside	22.00	910.18	Static
02/03/81	City of Riverside	20.50	911.68	Static
02/10/81	City of Riverside	20.00	912.18	Static
02/11/81	SB	20.03	912.15	Static
02/17/81	City of Riverside	20.10	912.08	Static
02/24/81	City of Riverside	20.50	911.68	Static
02/24/81	WMWD	19.85	912.33	Static
03/03/81	City of Riverside	20.00	912.18	Static
03/10/81	City of Riverside	20.20	911.98	Static
03/13/81	SB	20.48	911.70	Static
03/17/81	City of Riverside	20.50	911.68	Static
03/25/81	City of Riverside	20.90	911.28	Static
03/27/81	WMWD	20.80	911.38	Static

**Western San Bernardino Watermaster
Well Measurement Record for**

Flume #2

State Well Number 1S/4W29H01S

Basin: Riverside North

Reference Point Elevation: 932.18

Date	Obtained from	Ref. Pt. to Water	Water Surface Elevation	Remarks
04/07/81	City of Riverside	21.00	911.18	Static
04/14/81	City of Riverside	21.90	910.28	Static
04/15/81	SB	21.47	910.71	Static
04/21/81	City of Riverside	22.00	910.18	Static
05/07/81	WMWD	22.00	910.18	Static
05/14/81	SB	22.46	909.72	Static
05/29/81	City of Riverside	21.70	910.48	Static
06/18/81	City of Riverside	23.00	909.18	Static
06/22/81	City of Riverside	23.10	909.08	Static
06/29/81	City of Riverside	23.60	908.58	Static
07/10/81	WMWD	22.65	909.53	Static
07/16/81	SB	22.85	909.33	Static
07/22/81	City of Riverside	23.40	908.78	Static
07/29/81	City of Riverside	23.90	908.28	Static
08/13/81	SB	23.05	909.13	Static
08/18/81	WMWD	22.60	909.58	Static
08/19/81	City of Riverside	23.20	908.98	Static
08/26/81	City of Riverside	23.80	908.38	Static
09/02/81	City of Riverside	23.90	908.28	Low
09/15/81	SB	23.10	909.08	Static
10/13/81	City of Riverside	27.50	904.68	Reading Error?
10/16/81	SB	23.15	909.03	Static
10/27/81	City of Riverside	22.00	910.18	Static
11/10/81	WMWD	23.10	909.08	Static
11/20/81	SB	23.15	909.03	Static
12/01/81	City of Riverside	20.00	912.18	Static
12/22/81	WMWD	21.07	911.11	Static
12/31/81	City of Riverside	21.20	910.98	Static

1982

01/06/82	City of Riverside	21.50	910.68	
01/14/82	City of Riverside	20.00	912.18	
02/16/82	City of Riverside	21.00	911.18	
02/23/82	City of Riverside	21.20	910.98	
03/02/82	City of Riverside	20.60	911.58	
03/09/82	City of Riverside	20.70	911.48	
03/16/82	City of Riverside	20.30	911.88	
03/23/82	City of Riverside	19.90	912.28	
03/30/82	City of Riverside	19.70	912.48	

**Western San Bernardino Watermaster
Well Measurement Record for**

Flume #2

State Well Number 1S/4W29H01S

Basin: Riverside North

Reference Point Elevation: 932.18

Date	Obtained from	Ref. Pt. to Water	Water Surface Elevation	Remarks
04/06/82	City of Riverside	20.00	912.18	
04/13/82	City of Riverside	19.70	912.48	
04/20/82	City of Riverside	19.90	912.28	
04/27/82	City of Riverside	21.20	910.98	
05/04/82	City of Riverside	20.50	911.68	
05/10/82	WMWD	20.40	911.78	
05/11/82	City of Riverside	20.90	911.28	
05/18/82	City of Riverside	21.10	911.08	
05/25/82	City of Riverside	21.80	910.38	
06/01/82	City of Riverside	22.20	909.98	
06/08/82	City of Riverside	22.80	909.38	
06/22/82	City of Riverside	23.00	909.18	
07/01/82	City of Riverside	23.30	908.88	
07/06/82	City of Riverside	23.40	908.78	
07/13/82	City of Riverside	23.60	908.58	
07/20/82	City of Riverside	23.80	908.38	
08/01/82	City of Riverside	23.90	908.28	
08/03/82	City of Riverside	23.20	908.98	
08/10/82	City of Riverside	23.50	908.68	
08/17/82	City of Riverside	24.00	908.18	
08/25/82	City of Riverside	24.70	907.48	Low
09/01/82	City of Riverside	23.80	908.38	
09/08/82	City of Riverside	24.80	907.38	
09/14/82	City of Riverside	24.40	907.78	
09/21/82	City of Riverside	24.40	907.78	
10/01/82	City of Riverside	24.30	907.88	
10/05/82	City of Riverside	24.40	907.78	
10/19/82	City of Riverside	24.80	907.38	
10/26/82	City of Riverside	24.40	907.78	
11/02/82	City of Riverside	24.70	907.48	
11/09/82	City of Riverside	24.90	907.28	
11/16/82	City of Riverside	23.30	908.88	
11/23/82	City of Riverside	23.00	909.18	
12/01/82	City of Riverside	21.90	910.28	
12/14/82	City of Riverside	22.90	909.28	
12/21/82	City of Riverside	22.20	909.98	
12/27/82	City of Riverside	21.10	911.08	
12/28/82	WMWD	21.80	910.38	

**Western San Bernardino Watermaster
Well Measurement Record for**

Flume #2

State Well Number 1S/4W29H01S

Basin: Riverside North

Reference Point Elevation: 932.18

Date	Obtained from	Ref. Pt. to Water	Water Surface Elevation	Remarks
1983				
01/13/83	City of Riverside	21.90	910.28	
01/18/83	City of Riverside	22.20	909.98	
01/25/83	City of Riverside	21.60	910.58	
02/01/83	City of Riverside	21.00	911.18	
02/08/83	City of Riverside	21.00	911.18	
02/15/83	City of Riverside	21.10	911.08	
02/22/83	City of Riverside	21.10	911.08	
03/01/83	City of Riverside	19.20	912.98	
03/08/83	City of Riverside	19.50	912.68	
03/15/83	City of Riverside	19.60	912.58	
03/22/83	City of Riverside	19.70	912.48	
04/01/83	City of Riverside	19.50	912.68	
04/05/83	City of Riverside	19.80	912.38	
04/12/83	City of Riverside	19.80	912.38	
04/19/83	City of Riverside	19.90	912.28	
04/26/83	City of Riverside	20.00	912.18	
05/01/83	City of Riverside	20.00	912.18	
05/03/83	City of Riverside	19.50	912.68	
05/10/83	City of Riverside	19.50	912.68	
05/24/83	City of Riverside	21.40	910.78	
05/29/83	City of Riverside	23.40	908.78	
06/21/83	City of Riverside	21.00	911.18	(?)
06/29/83	City of Riverside	21.00	911.18	
07/12/83	City of Riverside	22.00	910.18	
07/19/83	City of Riverside	20.90	911.28	
07/26/83	City of Riverside	21.00	911.18	
08/30/83	City of Riverside	20.60	911.58	
09/01/83	City of Riverside	20.60	911.58	
09/01/83	WMWD	20.10	912.08	
09/07/83	City of Riverside	20.60	911.58	
09/13/83	City of Riverside	20.80	911.38	
09/20/83	City of Riverside	20.80	911.38	
09/27/83	City of Riverside	20.80	911.38	
10/04/83	City of Riverside	19.90	912.28	
10/11/83	City of Riverside	19.60	912.58	
10/18/83	City of Riverside	19.90	912.28	
10/25/83	City of Riverside	20.60	911.58	
11/01/83	City of Riverside	20.80	911.38	

**Western San Bernardino Watermaster
Well Measurement Record for**

Flume #2

State Well Number 1S/4W29H01S

Basin: Riverside North

Reference Point Elevation: 932.18

Date	Obtained from	Ref. Pt. to Water	Water Surface Elevation	Remarks
11/01/83	WMWD	20.20	911.98	
11/08/83	City of Riverside	20.70	911.48	
11/16/83	City of Riverside	20.60	911.58	
11/22/83	City of Riverside	20.50	911.68	
12/01/83	City of Riverside	20.10	912.08	
12/06/83	City of Riverside	19.70	912.48	
12/20/83	City of Riverside	20.30	911.88	
12/27/83	City of Riverside	19.00	913.18	
1984				
01/01/84	City of Riverside	20.30	911.88	
01/10/84	City of Riverside	19.30	912.88	
01/17/84	City of Riverside	19.40	912.78	
01/24/84	City of Riverside	31.60	900.58	(?)
02/01/84	City of Riverside	20.10	912.08	
02/07/84	City of Riverside	20.50	911.68	
02/14/84	City of Riverside	20.60	911.58	
02/21/84	City of Riverside	20.60	911.58	
03/01/84	City of Riverside	20.60	911.58	
03/08/84	City of Riverside	21.40	910.78	
03/20/84	City of Riverside	21.00	911.18	
04/01/84	City of Riverside	20.90	911.28	
04/03/84	City of Riverside	21.00	911.18	
04/25/84	City of Riverside	20.90	911.28	
04/30/84	City of Riverside	21.00	911.18	
05/01/84	City of Riverside	21.00	911.18	
05/08/84	City of Riverside	21.10	911.08	
05/15/84	City of Riverside	21.20	910.98	
05/22/84	City of Riverside	21.30	910.88	
06/01/84	City of Riverside	21.30	910.88	
06/12/84	City of Riverside	22.20	909.98	
06/19/84	City of Riverside	21.50	910.68	
07/01/84	City of Riverside	22.50	909.68	
07/10/84	City of Riverside	22.70	909.48	
08/01/84	City of Riverside	22.50	909.68	
09/01/84	City of Riverside	21.90	910.28	
10/01/84	City of Riverside	23.60	908.58	
10/02/84	WMWD	23.30	908.88	
11/01/84	City of Riverside	23.90	908.28	

**Western San Bernardino Watermaster
Well Measurement Record for**

Flume #2

State Well Number 1S/4W29H01S

Basin: Riverside North

Reference Point Elevation: 932.18

Date	Obtained from	Ref. Pt. to Water	Water Surface Elevation	Remarks
12/01/84	City of Riverside	24.10	908.08	Low

**Western San Bernardino Watermaster
Well Measurement Record for**

Flume #2

State Well Number 1S/4W29H01S

Basin: Riverside North

Reference Point Elevation: 932.18

after Jan 2008 932.45

935.088 see note in comment box

Date	Obtained from	Ref. Pt. to Water	Water Surface Elevation	Remarks
1985				
02/01/85	City of Riverside	21.00	911.18	
03/01/85	City of Riverside	21.70	910.48	
03/05/85	City of Riverside	21.80	910.38	
03/14/85	City of Riverside	22.00	910.18	
03/19/85	City of Riverside	22.10	910.08	
03/26/85	City of Riverside	22.10	910.08	
04/01/85	City of Riverside	22.10	910.08	
04/02/85	City of Riverside	22.00	910.18	
04/09/85	City of Riverside	22.20	909.98	
04/16/85	City of Riverside	22.30	909.88	
04/23/85	City of Riverside	22.40	909.78	
05/01/85	City of Riverside	22.40	909.78	
06/01/85	City of Riverside	22.40	909.78	
07/01/85	City of Riverside	24.10	908.08	
08/01/85	City of Riverside	24.10	908.08	
09/01/85	City of Riverside	25.50	906.68	Low
10/01/85	City of Riverside	24.90	907.28	
12/01/85	City of Riverside	24.80	907.38	
1986				
01/01/86	C of R	22.80	909.38	
02/01/86	C of R	23.70	908.48	
02/11/86	C of R	23.00	909.18	
03/25/86	C of R	21.20	910.98	
04/01/86	C of R	21.50	910.68	
04/08/86	C of R	21.60	910.58	
05/06/86	C of R	22.00	910.18	
05/13/86	C of R	22.60	909.58	
05/20/86	C of R	22.70	909.48	
05/27/86	WMWD	22.00	910.18	
06/17/86	C of R	23.00	909.18	
07/20/86	C of R	23.60	908.58	
08/05/86	C of R	23.60	908.58	
08/12/86	C of R	24.00	908.18	
08/26/86	C of R	24.40	907.78	
09/02/86	C of R	24.70	907.48	
09/16/86	WMWD	24.50	907.68	
09/23/86	C of R	25.10	907.08	
10/24/86	WMWD	23.00	909.18	
11/19/86	C of R	25.60	906.58	Low for the year
12/29/86	C of R	25.60	906.58	
1987				
01/06/87	WMWD	23.30	908.88	
01/28/87	C of R	23.20	908.98	
03/03/87	C of R	25.80	906.38	
03/31/87	C of R	25.60	906.58	
04/20/87	WMWD	28.00	904.18	
04/30/87	C of R	28.70	903.48	
06/10/87	C of R	29.00	903.18	

**Western San Bernardino Watermaster
Well Measurement Record for**

Flume #2

State Well Number 1S/4W29H01S

Basin: Riverside North

Reference Point Elevation: 932.18

after Jan 2008 932.45

935.088 see note in comment box

Date	Obtained from	Ref. Pt. to Water	Water Surface Elevation	Remarks
07/06/87	C of R	28.70	903.48	
08/09/87	C of R	29.10	903.08	
08/16/87	C of R	27.60	904.58	
08/25/87	C of R	29.20	902.98	Low for the year
09/24/87	C of R	27.30	904.88	
11/03/87	C of R	13.80	918.38	?
11/10/87	C of R	26.90	905.28	
12/08/87	C of R	26.60	905.58	
12/22/87	C of R	26.60	905.58	
12/23/87	WMWD	26.00	906.18	
12/29/87	C of R	27.50	904.68	
1988				
01/05/88	C of R	26.90	905.28	
01/12/88	C of R	26.90	905.28	
01/19/88	C of R	26.20	905.98	
01/26/88	C of R	26.10	906.08	
03/01/88	C of R	26.00	906.18	
03/08/88	C of R	25.80	906.38	
04/15/88	C of R	35.50	896.68	
05/01/88	C of R	26.00	906.18	
06/28/88	C of R	32.30	899.88	
07/01/88	C of R	32.30	899.88	
07/05/88	C of R	34.60	897.58	
07/12/88	C of R	36.00	896.18	
08/01/88	C of R	36.40	895.78	Low for the year
08/17/88	C of R	33.50	898.68	
09/01/88	C of R	34.70	897.48	
10/01/88	C of R	34.70	897.48	
11/01/88	C of R	31.00	901.18	
1989				
01/01/89	C of R	32.80	899.38	
01/26/89	C of R	36.40	895.78	
02/01/89	C of R	36.40	895.78	
02/09/89	C of R	32.40	899.78	
02/22/89	C of R	33.60	898.58	
03/01/89	C of R	33.60	898.58	
03/12/89	C of R	34.90	897.28	
03/19/89	C of R	40.10	892.08	
03/25/89	C of R	33.20	898.98	
04/28/89	C of R	37.60	894.58	
05/05/89	C of R	38.80	893.38	
05/11/89	C of R	38.70	893.48	
06/11/89	C of R	40.90	891.28	
06/16/89	C of R	38.90	893.28	
06/30/89	C of R	41.10	891.08	
08/28/89	C of R	42.30	889.88	
09/26/89	C of R	42.80	889.38	
10/11/89	C of R	45.40	886.78	
10/17/89	C of R	44.10	888.08	
10/31/89	C of R	42.90	889.28	

**Western San Bernardino Watermaster
Well Measurement Record for**

Flume #2

State Well Number 1S/4W29H01S

Basin: Riverside North

Reference Point Elevation: 932.18

after Jan 2008 932.45

935.088 see note in comment box

Date	Obtained from	Ref. Pt. to Water	Water Surface Elevation	Remarks
11/10/89	C of R	45.00	887.18	
11/18/89	C of R	44.80	887.38	
11/24/89	C of R	44.50	887.68	
12/01/89	C of R	44.50	887.68	
12/09/89	C of R	45.00	887.18	
12/16/89	C of R	44.50	887.68	
12/23/89	C of R	45.00	887.18	
12/31/89	C of R	45.90	886.28	Low for the year
1990				
01/06/90	C of R	45.20	886.98	
01/13/90	C of R	45.50	886.68	
01/19/90	C of R	45.00	887.18	
01/25/90	C of R	44.00	888.18	
02/03/90	C of R	44.50	887.68	
02/10/90	C of R	44.50	887.68	
02/24/90	C of R	41.00	891.18	
03/07/90	C of R	41.50	890.68	
03/12/90	C of R	43.70	888.48	
04/02/90	C of R	44.50	887.68	
05/22/90	WMWD	44.10	888.08	
06/06/90	C of R	44.00	888.18	
07/09/90	C of R	46.00	886.18	
07/30/90	C of R	46.70	885.48	
09/19/90	C of R	45.30	886.88	
10/31/90	C of R	44.70	887.48	
12/02/90	C of R	50.00	882.18	Low for the year
12/17/90	WMWD	49.90	882.28	
1991				
01/15/91	C of R	47.20	884.98	
01/28/91	C of R	49.00	883.18	
03/04/91	C of R	44.00	888.18	
03/21/91	C of R	43.30	888.88	
04/16/91	C of R	48.00	884.18	
04/29/91	C of R	43.10	889.08	
05/13/91	C of R	47.00	885.18	
05/31/91	WMWD	47.90	884.28	Low for the year
08/23/91	C of R	86.50	845.68	Pumping
10/10/91	C of R	87.00	845.18	Pumping
1992				
01/16/92	WMWD	59.35	872.83	
02/03/92	C of R	53.10	879.08	Pumping
02/22/92	C of R	57.80	874.38	Static ?
03/11/92	C of R	55.80	876.38	
04/07/92	C of R	49.50	882.68	
11/24/92	C of R	63.00	869.18	Flume #3 pumping
12/15/93	C of R	59.00	873.18	Low for the year
1993				
01/23/93	C of R	35.30	896.88	

**Western San Bernardino Watermaster
Well Measurement Record for**

Flume #2

State Well Number 1S/4W29H01S

Basin: Riverside North

Reference Point Elevation: 932.18

after Jan 2008 932.45

935.088 see note in comment box

Date	Obtained from	Ref. Pt. to Water	Water Surface Elevation	Remarks
03/15/93	C of R	35.00	897.18	
04/15/93	C of R	35.00	897.18	
05/04/93	C of R	35.00	897.18	Low for the year
06/08/93	C of R	35.00	897.18	
08/30/93	C of R	58.00	874.18	Pumping
09/07/93	C of R	58.80	873.38	Pumping
10/23/93	USGS	19.67	912.51	
10/26/93	C of R	20.00	912.18	
12/28/93	C of R	18.60	913.58	
1994				
01/05/94	WMWD	19.80	912.38	
02/22/94	C of R	20.00	912.18	
05/25/94	C of R	20.00	912.18	
05/31/94	WMWD	20.00	912.18	
10/24/94	USGS	21.29	910.89	
11/24/94	C of R	21.80	910.38	
12/06/94	C of R	22.30	909.88	Low for the year
1995				
05/04/95	C of R	17.10	915.08	
05/24/95	WMWD	16.60	915.58	Low for the year
1996				
02/03/96	C of R	16.80	915.38	
02/23/96	C of R	16.50	915.68	
03/04/96	WMWD	17.30	914.88	
04/12/96	WMWD/SBVMWD	22.60	909.58	Rix startup
04/23/97	USGS	25.40	906.78	
05/10/96	WMWD	-	-	Pumping
05/14/96	SBVMWD	-	-	Pumping
05/22/96	C of R	66.00	866.18	Pumping
06/14/96	SBVMWD	-	-	Pumping
07/05/96	WMWD	-	-	Pumping
07/19/96	SBVMWD	43.00	889.18	Low for the year
08/06/96	WMWD	-	-	Pumping
08/20/96	SBVMWD	-	-	Pumping
10/08/97	USGS	-	-	Pumping
10/16/96	SBVMWD	-	-	Pumping
11/04/96	WMWD	-	-	Pumping
11/18/96	SBVMWD	-	-	Pumping
12/09/96	WMWD	-	-	Pumping
12/17/96	SBVMWD	-	-	Pumping
1997				
01/16/97	SBVMWD	25.40	906.78	River flowing
02/19/97	SBVMWD	26.00	906.18	
03/18/97	SBVMWD	29.90	902.28	
03/31/97	C of R	43.30	888.88	?
04/18/97	SBVMWD	-	-	Pumping
04/30/97	C of R	25.40	906.78	
05/05/97	WMWD	75.30	-	Pumping

**Western San Bernardino Watermaster
Well Measurement Record for**

Flume #2

State Well Number 1S/4W29H01S

Basin: Riverside North

Reference Point Elevation: 932.18

after Jan 2008 932.45

935.088 see note in comment box

Date	Obtained from	Ref. Pt. to Water	Water Surface Elevation	Remarks
05/20/97	SBVMWD	-	-	Pumping
06/17/97	SBVMWD	-	-	Pumping
07/16/97	SBVMWD	-	-	Pumping
09/16/97	SBVMWD	Below 32'	-	
10/16/97	SBVMWD	Below 32'	-	
11/18/97	SBVMWD	Below 32'	-	Pumping
12/16/97	SBVMWD	48.80	883.38	Low for the year
12/29/97	WMWD	48.00	884.18	
1998				
01/10/98	C of R	47.00	885.18	
02/19/98	SBVMWD	-	-	Tape stuck
02/21/98	C of R	28.20	903.98	
04/08/98	C of R	22.30	909.88	
04/20/98	SBVMWD	-	-	Tape stuck
06/01/98	WMWD	18.50	913.68	
06/18/98	SBVMWD	11.00	921.18	
07/14/98	SBVMWD	-	-	
08/05/98	C of R	53.50	878.68	Pumping
08/17/98	SBVMWD	-	-	
09/17/98	SBVMWD	-	-	
11/10/98	SBVMWD	-	-	Pumping
12/18/98	SBVMWD	-	-	
1999				
01/09/99	C of R	26.60	905.58	Low for "98" year
01/18/99	WMWD	25.80	906.38	
01/19/99	SBVMWD	-	-	
02/16/99	SBVMWD	-	-	
03/17/99	SBVMWD	-	-	
04/14/99	SBVMWD	-	-	
05/19/99	C of R	57.10	-	Pumping
06/03/99	WMWD	-	-	Pumping
07/27/99	C of R	13.8 ?	-	Pumping
10/07/99	C of R	65.00	-	Pumping
12/28/99	WMWD	-	-	Pumping
2000				
01/05/00	C of R	68.8	-	Pumping
03/21/00	C of R	27.80	904.38	Low for year
05/09/00	WMWD	-	-	Pumping
09/18/00	C of R	-	-	Cannot measure
12/04/00	C of R	80.60	851.58	#2 on, #6 on
2001				
01/20/01	C of R	52.10	880.08	
02/16/01	C of R	29.20	902.98	#2 off, #6 off
03/09/01	WMWD	45.35	886.83	
03/09/01	WMWD	42.35	889.83	
04/23/01	C of R	-	-	Cannot measure
06/08/01	WMWD	46.31	885.87	
11/16/01	WMWD	83.80	848.38	Pumping

**Western San Bernardino Watermaster
Well Measurement Record for**

Flume #2

State Well Number 1S/4W29H01S

Basin: Riverside North

Reference Point Elevation: 932.18

after Jan 2008 932.45

935.088 see note in comment box

Date	Obtained from	Ref. Pt. to Water	Water Surface Elevation	Remarks
11/28/01	WMWD	60.90	871.28	Pumping
12/04/01	C of R	58.50	873.68	idle / LOW
2002				
01/12/02	C of R	59.00	873.18	Idle
02/14/02	C of R	--	--	Cannot measure
03/28/02	C of R	--	--	Cannot measure
05/01/02	WMWD	59.80	872.38	Idle
05/03/02	C of R	--	--	Cannot measure
06/11/02	C of R	62.80	869.38	Static
09/19/02	C of R	114.30	817.88	Pumping
11/18/02	C of R	69.00	863.18	Static, LOW
11/28/02	WMWD	--	--	Pumping
12/11/02	WMWD	--	--	Cannot measure
12/20/02	C of R	69.30	862.88	Static
2003				
03/05/03	C of R	66.50	865.68	
04/23/03	USGS	60.87	871.31	
05/09/03	WMWD	-	-	Tape hangs up
10/21/03	USGS	72.21	859.97	
11/19/03	C of R	73.00	859.18	Static / LOW
12/08/03	WMWD	-	-	Tape hangs up
12/22/03	C of R	73.50	858.68	
2004				
03/11/04	C of R	72.90	859.28	
05/01/04	C of R	71.80	860.38	
05/04/04	WMWD	-	-	Tape hangs up @ 36'
05/11/04	C of R	72.80	859.38	
06/15/04	C of R	75.90	856.28	Date estimated
07/05/04	C of R	75.90	856.28	Date estimated
09/15/04	C of R	75.70	856.48	Date estimated
10/25/04	USGS	76.30	855.88	LOW
12/16/04	C of R	72.70	859.48	
2005				
04/21/05	WMWD	22.00	910.18	Motor replaced, est new MP
05/27/05	WMWD	23.00	909.18	LOW
07/15/05	C of R	21.20	910.98	static
07/25/05	USGS	19.81	912.37	static
10/04/05	C of R	74.90	857.28	static ?
10/10/05	WMWD	68.30	863.88	Pumping ?
11/14/05	WMWD	75.09	857.09	Pumping 1500 gpm
11/15/05	C of R	74.90	857.28	Pumping
12/12/05	WMWD	-	-	Pumping 1500 gpm
2006				
01/09/06	WMWD	77.88	854.30	Pumping 1500 gpm
02/13/06	WMWD	79.80	852.38	#2 on, #3 on, #4 off, #6 off
03/13/06	WMWD	34.75	897.43	#2 off, #3off, #4 off, #6 off
04/10/06	WMWD	26.98	905.20	#2 off, #3off, #4 off, #6 off

**Western San Bernardino Watermaster
Well Measurement Record for**

Flume #2

State Well Number 1S/4W29H01S

Basin: Riverside North

Reference Point Elevation: 932.18

after Jan 2008 932.45

935.088 see note in comment box

Date	Obtained from	Ref. Pt. to Water	Water Surface Elevation	Remarks
04/25/06	USGS	25.00	907.18	static
05/08/06	WMWD	69.05	863.13	#2 on, #3 on, #4 off, #6 off
06/10/06	WMWD	75.08	857.10	#2 on, #3 on, #4 off, #6 on
06/14/06	C of R	75.70	856.48	pumping
07/11/06	WMWD	78.85	853.33	#2 on, #3 on, #4 off, #6 on
08/14/06	WMWD	80.07	852.11	#2 on, #3 on, #4 on, #6 off
09/11/06	WMWD	-	-	#2 on, #3 on, #4 on, #6 off
10/04/06	C of R	60.80	871.38	#2 off, #3 off, #4 off, #6 off / LOW
10/09/06	WMWD	51.03	881.15	#2 off, #3 off, #4 off, #6 off
10/25/06	USGS	-	-	pumping
11/10/06	C of R	76.00	856.18	pumping
11/13/06	WMWD	80.30	851.88	#2 on, #3 on, #4 on, #6 off
12/11/06	WMWD	58.30	873.88	#2 off, #3 on, #4 on, #6 on
2007				
01/08/07	WMWD	56.87	875.31	#2 off, #3 off, #4 off, #6 off
01/14/07	C of R	56.50	875.68	
01/22/07	SBVMWD	locked out		#2 off, #3 off, #4 off, #6 off
02/01/07	WMWD	-	-	Locked out
02/15/07	SBVMWD	locked out		#2 off, #3 off, #4 off, #6 off
02/21/07	C of R	52.00	880.18	
03/12/07	WMWD	52.55	879.63	
03/23/07	SBVMWD	locked out		#2 off, #3 off, #4 off, #6 off
04/11/07	WMWD	56.12	876.06	
04/12/07	C of R	63.00	869.18	Watermaster questions reading of 63'
04/19/07	USGS	53.77	878.41	Static
04/27/07	SBVMWD	locked out		#2 off, #3 off, #4 off, #6 off
05/14/07	WMWD	55.63	876.55	
05/16/07	C of R	56.00	876.18	
05/25/07	SBVMWD	locked out		#2 off, #3 off, #4 off, #6 off
06/09/07	C of R	60.20	871.98	
06/11/07	WMWD			#2 off, #3 off, #4 off, #6 off
06/14/07	SBVMWD	locked out		#2 off, #3 off, #4 off, #6 off
07/10/07	C of R	60.50	871.68	
07/11/07	WMWD	57.70	874.48	#2 off, #3 off, #4 off, #6 off
07/19/07	SBVMWD	locked out		#2 off, #3 off, #4 off, #6 off
08/09/07	C of R	63.00	869.18	
08/13/07	WMWD			#2 off, #3 off, #4 off, #6 off
08/16/07	SBVMWD	locked out		#2 off, #3 off, #4 off, #6 off
09/10/07	WMWD			#2 off, #3 off, #4 off, #6 off
09/14/07	C of R	60.10	872.08	
09/17/07	SBVMWD	locked out		#2 off, #3 off, #4 off, #6 off
10/08/07	WMWD	62.02	870.16	#2 off, #3 off, #4 off, #6 off
10/26/07	SBVMWD	locked out		#2 off, #3 off, #4 off, #6 off
10/30/07	USGS	61.80	870.38	Static
11/19/07	SBVMWD	locked out		#2 off, #3 off, #4 off, #6 off
11/28/07	WMWD	62.93	869.25	LOW
12/13/07	SBVMWD	locked out		#2 off, #3 off, #4 off, #6 off
12/21/07	C of R	55.00	877.18	

**Western San Bernardino Watermaster
Well Measurement Record for**

Flume #2

State Well Number 1S/4W29H01S

Basin: Riverside North

Reference Point Elevation: 932.18

after Jan 2008 932.45

935.088 see note in comment box

Date	Obtained from	Ref. Pt. to Water	Water Surface Elevation	Remarks
2008				
01/14/08	City of Riverside	49.13	883.32	
01/16/08	Watermaster	48.93	883.52	#2 off, #3 off, #4 off, #6 off
03/19/08	Watermaster	48.55	883.90	#2 off, #3 off, #4 off, #6 off
04/02/08	Watermaster	50.91	881.54	#2 off, #3 off, #4 off, #6 off
04/15/08	USGS	52.57	879.88	Static
05/07/08	Watermaster	55.10	877.35	#2 off, #3 off, #4 off, #6 off
06/05/08	Watermaster	77.43	855.02	#2 on, #3 off, #4 off, #6 on
07/02/08	Watermaster	-	-	Locked out
07/24/08	City of Riverside	68.79	863.66	
08/06/08	Watermaster	82.85	849.60	#2 on, #3 on #4 on #6 on
09/03/08	Watermaster			Locked out
09/08/08	Watermaster	87.44	845.01	#2 on, #3 on #4 on #6 on
09/30/08	City of Riverside	78.61	853.84	
10/01/08	City of Riverside	78.18	854.27	
10/01/08	Watermaster	78.18	854.27	#2 off, #3 off #4 off #6 off / LOW
10/20/08	USGS	81.03	851.42	
11/06/08	Watermaster	89.90	842.55	#2 on, #3 on #4 on #6 on
12/04/08	Watermaster	90.55	841.90	#2 on, #3 on #4 on #6 on
2009				
01/08/09	Watermaster	88.05	844.40	Pumping; #2 on, #3 on, #4 on, #6 on
01/19/09	City of Riverside	72.69	859.76	Static
01/20/09	City of Riverside	73.84	858.61	Colton pump test
01/21/09	City of Riverside	74.42	858.03	Colton pump test
01/25/09	City of Riverside	71.99	860.46	Static
02/04/09	Watermaster	71.29	861.16	Static; #2 off, #3 off, #4 off, #6 off
03/04/09	City of Riverside	64.44	868.01	Static
03/04/09	Watermaster	64.51	867.94	Static
04/01/09	Watermaster	122.32	810.13	Pumping; #2 on, #3 on, #4 on, #6 on
05/06/09	Watermaster	128.46	803.99	Pumping; #2 on, #3 on, #4 on, #6 off
05/14/09	City of Riverside	129.85	802.60	Pumping
06/03/09	Watermaster	133.04	799.41	Pumping; #2 on, #3 on, #4 on, #6 on
06/18/09	City of Riverside	133.60	798.85	Pumping
07/01/09	Watermaster	133.43	799.02	Pumping; #2 on, #3 on, #4 on, #6 on
07/15/09	City of Riverside	136.05	796.40	Pumping
08/05/09	Watermaster	139.12	793.33	Pumping; #2 on, #3 on, #4 on, #6 on
08/19/09	City of Riverside	140.70	791.75	Pumping
09/02/09	Watermaster	141.87	790.58	Pumping; #2 on, #3 on, #4 on, #6 on
09/15/09	City of Riverside	142.54	789.91	Pumping, #2 on, #3 on, #4 on, #6 on
10/08/09	City of Riverside	142.46	789.99	Pumping, #2 on, #3 on, #4 on
10/08/09	Watermaster	142.54	789.91	Pumping; #2 on, #3 on, #4 on, #6 off
10/09/09	Watermaster	98.11	834.34	Off overnight
10/09/09	City of Riverside	97.91	834.54	Static, no pumping (LOW)
11/04/09	Watermaster	142.10	790.35	Pumping; #2 on, #3 on, #4 on, #6 off
12/02/09	Watermaster	140.51	791.94	Pumping; #2 on, #3 off, #4 off, #6 off
12/04/09	City of Riverside	140.43	792.02	Pumping, #3 on, #4 on
12/28/09	City of Riverside	87.43	845.02	Static, all flume wells off
12/31/09	City of Riverside	133.20	799.25	Pumping

**Western San Bernardino Watermaster
Well Measurement Record for**

Flume #2

State Well Number 1S/4W29H01S

Basin: Riverside North

Reference Point Elevation: 932.18

after Jan 2008 932.45

935.088 see note in comment box

Date	Obtained from	Ref. Pt. to Water	Water Surface Elevation	Remarks
2010				
01/06/10	Watermaster	135.42	797.03	Pumping; #2 on, #3 on, #4 on, #6 off
02/03/10	Watermaster	74.08	858.37	Static; #2 off, #3 on, #4 on, #6 off
02/05/10	City of Riverside	74.29	858.16	All well off
03/03/10	Watermaster	70.22	862.23	Pumping; #2 off, #3 on, #4 on, #6 off
03/03/10	City of Riverside	70.18	862.27	
04/07/10	Watermaster	125.24	807.21	Pumping; #2 on, #3 on, #4 on, #6 off
05/05/10	Watermaster	128.19	804.26	Pumping; #2 on, #3 on, #4 on, #6 off
06/02/10	Watermaster	134.01	798.44	Pumping; #2 on, #3 on, #4 on, #6 off
07/07/10	Watermaster	139.83	792.62	Pumping; #2 on, #3 on, #4 on, #6 off
07/13/10	City of Riverside	140.50	791.95	
08/04/10	Watermaster	141.57	790.88	Pumping; #2 on, #3 on, #4 on, #6 off
09/01/10	Watermaster	142.78	789.67	Pumping; #2 on, #3 on, #4 on, #6 off
10/06/10	Watermaster	146.98	785.47	Pumping; #2 on, #3 on, #4 off, #6 off
10/22/10	City of Riverside	98.87	833.58	Static; #2 off, #3 on, #4 on, #6 off
10/27/10	City of Riverside	98.39	834.06	Static; #2 off, #3 on, #4 off, #6 off
11/03/10	Watermaster	96.16	836.29	#2 off, #3 off #4 off, #6 off, LOW
11/03/10	City of Riverside	96.15	836.30	All wells off for 4 day
12/01/10	Watermaster	90.53	841.92	Static; #2 off, #3 off #4 off, #6 off
2011				
01/02/11	Watermaster	73.40	859.05	off
01/14/11	City of Riverside	74.53	857.92	All well off
02/02/11	Watermaster	76.28	856.17	off
03/02/11	Watermaster	71.49	860.96	off
03/25/11	City of Riverside	70.70	861.75	
04/06/11	Watermaster	62.88	869.57	off
04/08/11	City of Riverside	62.60	869.85	#3 on, #4 on
05/04/11	Watermaster	57.04	875.41	off
05/06/11	City of Riverside	57.31	875.14	#3 on, #4 on
06/01/11	Watermaster	115.16	817.29	Pumping; #2 on, #3 on, #4 on, #6 off
07/06/11	Watermaster	124.31	808.14	Pumping; #2 on, #3 on, #4 on, #6 off
07/13/11	City of Riverside	121.00	811.45	Pumping
08/18/11	Watermaster	133.37	799.08	Pumping; #2 on, #3 on, #4 on, #6 off
09/07/11	Watermaster	136.67	795.78	Pumping; #2 on, #3 on, #4 on, #6 on
10/05/11	Watermaster	140.55	791.90	Pumping; #2 on, #3 on, #4 on, #6 on
11/02/11	City of Riverside	94.44	838.01	All Flume wells off 3 days
11/02/11	Watermaster	94.49	837.96	All Flume wells off 3 days, LOW
12/07/11	Watermaster	140.60	791.85	Pumping; #2 on, #3 on, #4 on, #6 off
2012				
01/04/12	Watermaster	141.38	791.07	Pumping; #2 on, #3 on, #4 on, #6 off
01/11/12	City of Riverside	138.00	794.45	Pumping
02/01/12	Watermaster	141.70	790.75	Pumping; #2 on, #3 on, #4 on, #6 off
03/07/12	Watermaster	139.46	792.99	Pumping; #2 on, #3 on, #4 on, #6 off
03/27/12	City of Riverside	134.00	798.45	Pumping
04/04/12	Watermaster	132.54	799.91	Pumping; #2 on, #3 off #4 on, #6 off
05/02/12	Watermaster	132.25	800.2	Pumping; #2 on, #3 on, #4 on, #6 off
05/02/12	City of Riverside	132.30	800.15	Static
05/16/12	City of Riverside	128.00	804.45	Pumping

**Western San Bernardino Watermaster
Well Measurement Record for**

Flume #2

State Well Number 1S/4W29H01S

Basin: Riverside North

Reference Point Elevation: 932.18

after Jan 2008 932.45

935.088 see note in comment box

Date	Obtained from	Ref. Pt. to Water	Water Surface Elevation	Remarks
06/06/12	Watermaster	135.00	797.45	Pumping; #2 on, #3 on, #4 on, #6 off
07/11/12	Watermaster	134.06	798.39	Pumping; #2 on, #3 on, #4 on, #6 off
08/01/12	Watermaster	137.88	794.57	Pumping; #2 on, #3 on, #4 on, #6 on
09/05/12	Watermaster	141.20	791.25	Pumping; #2 on, #3 on, #4 on, #6 on
10/10/12	Watermaster	142.82	789.63	Pumping; #2 on, #3 on, #4 on, #6 on
11/14/12	Watermaster	144.63	787.82	Pumping; #2 on, #3 on, #4 on, #6 off
11/16/12	Watermaster	111.12	821.33	Pumping; #2 off, #3 on, #4 off, #6 off , #7 on
11/16/12	City of Riverside	111.08	821.37	Static, taken at 14:04, 2 & 4 off at 07:00, 3
12/12/12	City of Riverside	109.62	822.83	Static, all Flume wells off +23 hrs - LOW
12/12/12	Watermaster	109.97	822.48	Static
12/13/12	City of Riverside	108.90	823.55	Static, All Flume wells off +45 hrs
12/13/12	Watermaster	108.94	823.51	Storm event peaked at E St Gage 1500 cfs on mc
12/14/12	City of Riverside	108.44	824.01	Static, all Flume wells of + 66 hrs
12/14/12	Watermaster	108.48	823.97	Static
12/17/12	City of Riverside	105.69	826.76	Static, all Flume wells off +137 hrs
12/17/12	Watermaster	105.69	826.76	Static
2013				
01/09/13	Watermaster	97.57	834.88	Off #2 off, #3 off, #4 off, #6 off , #7 off
01/30/13	City of Riverside	95.50	836.95	Static
02/13/13	Watermaster	92.98	839.47	Off #2 off, #3 off, #4 off, #6 off , #7 off
03/13/13	Watermaster	129.08	803.37	Pumping; #2 on #3 off, #4 off, #6 off , #7 on
03/21/13	City of Riverside	123.00	809.45	Pumping
04/10/13	Watermaster	132.59	799.86	Pumping; #2 on, #3 on, #4 on, #6 off , #7 ?
05/08/13	Watermaster	137.71	794.74	Pumping; #2 on, #3 on, #4 on, #6 off , #7 on
05/14/13	City of Riverside	132.00	800.45	Pumping
06/14/13	Watermaster	141.53	790.92	Pumping; #2 on, #3 on, #4 on, #6 off , #7 on
07/10/13	Watermaster	144.96	787.49	Pumping; #2 on, #3 on, #4 on, #6 off , #7 on
08/14/13	Watermaster	148.90	783.55	Pumping; #2 on, #3 on, #4 on, #6 off , #7 on
08/19/13	City of Riverside	147.00	785.45	Pumping
09/09/13	City of Riverside	106.00	826.45	Static
09/10/13	Watermaster	146.20	786.25	Pumping; #2 on, #3 on, #4 on, #6 off , #7 on
09/25/13	City of Riverside	147.00	785.45	Pumping
10/09/13	Watermaster	154.40	778.05	Pumping; #2 on, #3 on, #4 on, #6 off , #7 on
11/04/13	City of Riverside	109.00	823.45	Static
11/13/13	Watermaster	154.95	777.50	Pumping; #2 on, #3 on, #4 on, #6 off , #7 on
11/27/13	City of Riverside	114.39	818.06	Midnight picks from data logger after shutdown
11/27/13	City of Riverside	116.39	816.06	Manual reading
11/27/13	Watermaster	116.35	816.10	All Wells off
11/28/13	City of Riverside	113.44	819.01	Midnight picks from data logger after shutdown
11/29/13	City of Riverside	112.80	819.65	Midnight picks from data logger after shutdown
11/30/13	City of Riverside	112.31	820.14	Midnight picks from data logger after shutdown
12/01/13	City of Riverside	111.66	820.79	Midnight picks from data logger after shutdown
12/02/13	City of Riverside	111.66	820.79	Manual reading
12/02/13	Watermaster	111.70	820.75	All Wells off / Low
12/11/13	Watermaster	111.36	821.09	Off; #2 off, #3 on, #4 on, #6 off, #7 on

Western San Bernardino Watermaster Well Measurement Record for

Flume No. 5

State Well Number 1S/4W-29Q01S

Water Level Records
1970-2013

Basin: Riverside North

Reference Point Elevation: 916.53

After January 2008, Reference Point Elevation: 913.22

After October 16, 2009, Reference Point Elevation: 913.448 / 914.622



close up of new Flume #5 measuring pipe' about 1977



Photo's clockwise from top left - Flume No. 5 measuring pipe 1977, Flume No. 5 Measuring pipe 2007, Flume No.5 new measuring box, 2010, New lid for data logger access.

**Western San Bernardino Watermaster
Well Measurement Record for**

Flume #5

State Well Number 1S/4W29Q01S

Basin: Riverside North	Reference Point Elevation:	924.37	
		923.92	A
		917.75	B
		916.53	C

Date	Obtained from	Ref. Pt to Water	Water Surface Elevation	Remarks
1970				
05/25/70		41.60	882.77	Static
06/01/70		42.00	882.37	Static
06/15/70		40.30	884.07	Static
06/22/70		45.60	878.77	Static
07/06/70		43.90	880.47	Static
07/13/70		45.40	878.97	Static
07/13/70		46.00	878.37	Static
07/27/70		46.50	877.87	Static
08/03/70		45.90	878.47	Static
08/17/70		46.70	877.67	Static
08/24/70		47.30	877.07	Static
09/14/70		45.40	878.97	Static
09/21/70		50.60	873.77	Static
10/05/70		50.00	874.37	Static
10/12/70		51.90	872.47	Static (Low)
11/02/70		51.70	872.67	Static
11/11/70		50.30	874.07	Static
11/16/70		50.20	874.17	Static
11/23/70		51.00	873.37	Static
12/28/70		--	--	(Unable to measure)
1971				New R.P. Elev. 923.92 - Top 3
02/25/71	City of Riverside	43.60	880.32	Static
04/12/71		47.00	876.92	Static
04/19/71		47.20	876.72	Static
05/10/71		48.00	875.92	Static
05/17/71		48.30	875.62	Static
05/24/71		45.00	878.92	Static
06/21/71		52.60	871.32	Static
06/28/71		52.30	871.62	Static
07/06/71		53.80	870.12	Static
07/12/71		53.80	870.12	Static
07/20/71		53.70	870.22	Static
07/26/71		52.90	871.02	Static
08/09/71		53.70	870.22	Static
08/16/71		53.80	870.12	Static
08/23/71		51.40	872.52	Static
09/06/71		55.90	868.02	Static
09/14/71		55.80	868.12	Static

**Western San Bernardino Watermaster
Well Measurement Record for**

Flume #5

State Well Number 1S/4W29Q01S

Basin: Riverside North	Reference Point Elevation:	924.37	
		923.92	A
		917.75	B
		916.53	C

Date	Obtained from	Ref. Pt to Water	Water Surface Elevation	Remarks
09/20/71		55.30	868.62	Static
09/27/71		56.00	867.92	Static (Low)
09/30/71		55.80	868.12	Static
10/04/71		55.50	868.42	Static
10/11/71		60.10	863.82	Static
10/18/71		55.10	868.82	Static
11/01/71		54.70	869.22	Static
11/09/71		52.60	871.32	Static
11/15/71		52.80	871.12	Static
11/22/71		51.20	872.72	Static
12/02/71		51.20	872.72	Static
12/06/71		50.10	873.82	Static
12/13/71		50.40	873.52	Static
12/20/71		50.20	873.72	Static
12/27/71		53.10	870.82	Static

1972

01/03/72	City of Riverside	49.10	874.82	Static
01/10/72	City of Riverside	48.80	875.12	Static
01/17/72	City of Riverside	49.00	874.92	Static
01/24/72	City of Riverside	50.10	873.82	Static
02/01/72	City of Riverside	51.40	872.52	Static
02/07/72	City of Riverside	52.30	871.62	Static
02/14/72	City of Riverside	53.70	870.22	Static
02/21/72	City of Riverside	59.60	864.32	Static
02/28/72	City of Riverside	60.40	863.52	Static
03/06/72	City of Riverside	57.20	866.72	Static
03/13/72	City of Riverside	56.90	867.02	Static
03/20/72	City of Riverside	58.80	865.12	Static
03/27/72	City of Riverside	58.90	865.02	Static
04/01/72	City of Riverside	58.20	865.72	Static
04/10/72	City of Riverside	60.30	863.62	Static
05/01/72	City of Riverside	65.60	858.32	Static
05/08/72	City of Riverside	61.80	862.12	Static
05/15/72	City of Riverside	62.50	861.42	Static
05/22/72	City of Riverside	62.40	861.52	Static
06/01/72	City of Riverside	62.30	861.62	Static
06/05/72	City of Riverside	63.00	860.92	Static
06/12/72	City of Riverside	63.60	860.32	Static
06/19/72	City of Riverside	66.20	857.72	Static

**Western San Bernardino Watermaster
Well Measurement Record for**

Flume #5

State Well Number 1S/4W29Q01S

Basin: Riverside North	Reference Point Elevation:	924.37	
		923.92	A
		917.75	B
		916.53	C

Date	Obtained from	Ref. Pt to Water	Water Surface Elevation	Remarks
06/26/72	City of Riverside	65.00	858.92	Static
07/01/72	City of Riverside	65.30	858.62	Static
07/10/72	City of Riverside	64.50	859.42	Static
07/17/72	City of Riverside	65.20	858.72	Static
07/24/72	City of Riverside	65.40	858.52	Static
07/31/72	City of Riverside	65.80	858.12	Static
08/26/72	City of Riverside	66.30	857.62	Static
09/01/72	City of Riverside	67.50	856.42	Static
09/11/72	City of Riverside	67.00	856.92	Static
09/18/72	City of Riverside	68.20	855.72	Static
09/25/72	City of Riverside	68.50	855.42	Static
10/16/72	City of Riverside	73.60	850.32	Static
10/24/72	City of Riverside	70.90	853.02	Static
10/30/72	City of Riverside	70.60	853.32	Static
11/06/72	City of Riverside	70.80	853.12	Static
11/09/72	USGS	71.70	852.22	Static
11/14/72	City of Riverside	73.40	850.52	Static
11/20/72	City of Riverside	73.40	850.52	Static (Low)
11/27/72	City of Riverside	73.00	850.92	Static
11/28/72	USGS	63.97	859.95	Static
12/04/72	City of Riverside	72.50	851.42	Static
12/18/72	City of Riverside	62.80	861.12	Static
12/26/72	City of Riverside	65.10	858.82	Static
12/27/72	USGS	59.30	864.62	Static

1973

01/02/73	City of Riverside	-	-	Water in River. No measuremer
01/08/73	City of Riverside	-	-	No measurement
01/22/73	City of Riverside	63.70	860.22	Static
01/29/73	City of Riverside	43.30	880.62	Static
02/05/73	City of Riverside	63.40	860.52	Static
02/05/73	USGS	55.18	868.74	Static
02/20/73	City of Riverside	63.10	860.82	Static
02/26/73	City of Riverside	44.60	879.32	Static
02/28/73	USGS	51.71	872.21	Static
03/05/73	City of Riverside	45.10	878.82	Static
03/12/73	City of Riverside	-	-	River too high. No measuremer
04/02/73	USGS	50.78	873.14	Idle
04/16/73	City of Riverside	47.90	876.02	Idle
04/23/73	City of Riverside	47.70	876.22	Idle

**Western San Bernardino Watermaster
Well Measurement Record for**

Flume #5

State Well Number 1S/4W29Q01S

Basin: Riverside North	Reference Point Elevation:	924.37	
		923.92	A
		917.75	B
		916.53	C

Date	Obtained from	Ref. Pt to Water	Water Surface Elevation	Remarks
05/08/73	City of Riverside	-	-	Unable to measure.
05/27/73	City of Riverside	46.20	877.72	Idle
05/30/73	USGS	44.65	879.27	Idle
06/11/73	City of Riverside	46.10	877.82	Idle
06/18/73	City of Riverside	46.90	877.02	Idle
06/26/73	City of Riverside	48.50	875.42	Idle
07/01/73	City of Riverside	48.80	875.12	Idle
07/03/73	USGS	50.99	872.93	Idle
07/09/73	City of Riverside	48.50	875.42	Idle
07/16/73	City of Riverside	48.20	875.72	Idle
07/23/73	City of Riverside	48.10	875.82	Idle
07/25/73	USGS	47.99	875.93	Idle
08/06/73	City of Riverside	48.70	875.22	Idle
08/13/73	City of Riverside	48.70	875.22	Idle
08/20/73	City of Riverside	49.10	874.82	Idle
08/28/73	USGS	52.34	871.58	Idle
09/01/73	City of Riverside	49.40	874.52	Idle
09/10/73	City of Riverside	51.40	872.52	Idle
09/16/73	City of Riverside	58.70	865.22	Idle
10/01/73	City of Riverside	52.70	871.22	Idle
10/01/73	USGS	52.31	871.61	Idle
10/08/73	City of Riverside	52.40	871.52	Idle
10/16/73	City of Riverside	53.60	870.32	Idle
10/23/73	City of Riverside	54.20	869.72	Idle
10/30/73	City of Riverside	54.50	869.42	Idle (Low)
10/30/73	USGS	54.32	869.60	Idle
11/06/73	City of Riverside	53.90	870.02	Idle
11/13/73	City of Riverside	53.70	870.22	Idle
11/20/73	City of Riverside	52.60	871.32	Idle
11/27/73	City of Riverside	52.10	871.82	Idle
12/01/73	City of Riverside	52.40	871.52	Idle
12/04/73	City of Riverside	53.10	870.82	Idle
12/05/73	USGS	54.77	869.15	Idle
12/11/73	City of Riverside	52.90	871.02	Idle
12/18/73	City of Riverside	52.70	871.22	Idle
12/26/73	City of Riverside	52.60	871.32	Idle

1974

01/01/74	City of Riverside	52.20	871.72	Idle
01/01/74	USGS	49.69	874.23	Idle

**Western San Bernardino Watermaster
Well Measurement Record for**

Flume #5

State Well Number 1S/4W29Q01S

Basin: Riverside North	Reference Point Elevation:	924.37	
		923.92	A
		917.75	B
		916.53	C

Date	Obtained from	Ref. Pt to Water	Water Surface Elevation	Remarks
01/08/74	City of Riverside	-	-	Unable to measure. Can't forc
01/08/74	USGS	47.08	876.84	Idle
02/06/74	USGS	47.27	876.65	Idle
02/26/74	City of Riverside	56.20	867.72	Idle
04/02/74	City of Riverside	54.60	869.32	Idle
04/04/74	USGS	50.14	873.78	Idle
04/09/74	City of Riverside	54.20	869.72	Idle
04/17/74	City of Riverside	54.70	869.22	Idle
04/23/74	City of Riverside	56.20	867.72	Idle
04/30/74	City of Riverside	55.80	868.12	Idle
05/02/74	USGS	56.00	867.92	Idle
05/07/74	City of Riverside	54.10	869.82	Idle
05/14/74	City of Riverside	55.30	868.62	Idle
05/21/74	City of Riverside	54.60	869.32	Idle
05/28/74	City of Riverside	55.50	868.42	Idle
05/31/74	USGS	54.40	869.52	Idle
06/05/74	City of Riverside	56.20	867.72	Idle
06/25/74	City of Riverside	56.80	867.12	Idle
06/27/74	USGS	59.57	864.35	Idle
07/09/74	City of Riverside	55.70	868.22	Idle
07/17/74	City of Riverside	55.80	868.12	Idle
07/24/74	City of Riverside	56.30	867.62	Idle
07/25/74	SBVMWD	58.47	865.45	Idle
07/30/74	City of Riverside	56.90	867.02	Idle
08/09/74	City of Riverside	57.40	866.52	Idle
08/13/74	City of Riverside	56.90	867.02	Idle
08/20/74	City of Riverside	56.70	867.22	Idle
08/22/74	SBVMWD	59.78	864.14	Idle
08/27/74	City of Riverside	60.60	863.32	Idle
08/31/74	City of Riverside	60.60	863.32	Idle
09/03/74	City of Riverside	30.80	893.12	Idle
09/10/74	City of Riverside	61.70	862.22	Idle
09/24/74	City of Riverside	62.90	861.02	Idle
09/26/74	SBVMWD	60.72	863.20	Idle
10/01/74	City of Riverside	63.60	860.32	Idle
10/08/74	City of Riverside	64.40	859.52	Idle
10/16/74	City of Riverside	64.90	859.02	Idle
10/22/74	City of Riverside	65.10	858.82	Idle (Low)
10/24/74	SBVMWD	61.12	862.80	Idle
10/31/74	City of Riverside	64.00	859.92	Idle

**Western San Bernardino Watermaster
Well Measurement Record for**

Flume #5

State Well Number 1S/4W29Q01S

Basin: Riverside North	Reference Point Elevation:	924.37	
		923.92	A
		917.75	B
		916.53	C

Date	Obtained from	Ref. Pt to Water	Water Surface Elevation	Remarks
11/05/74	City of Riverside	61.20	862.72	Idle
11/12/74	City of Riverside	61.00	862.92	Idle
11/20/74	City of Riverside	61.80	862.12	Idle
11/22/74	SBVMWD	59.51	864.41	Idle
11/26/74	City of Riverside	62.00	861.92	Idle
12/01/74	City of Riverside	62.90	861.02	Idle
12/10/74	City of Riverside	62.70	861.22	Idle
12/24/74	City of Riverside	56.20	867.72	Idle
12/30/74	City of Riverside	56.60	867.32	Idle

1975

A=923.92 B=917.75 R.P.

01/07/75	City of Riverside	55.10	868.82	Static
01/14/75		55.80	868.12	Static
01/16/75	SBVMWD	54.82	869.10	Static
01/21/75	City of Riverside	57.40	866.52	Static
01/28/75	City of Riverside	59.20	864.72	Static
02/03/75	City of Riverside	59.60	864.32	Static
02/11/75	City of Riverside	54.20	869.72	Static
02/18/75	City of Riverside	53.00	870.92	Static
02/27/75	City of Riverside	52.40	871.52	Static
03/12/75	SBVMWD	49.29	874.63	Static
03/25/75	City of Riverside	51.60	872.32	Static
04/01/75	City of Riverside	51.90	872.02	Static
04/08/75	City of Riverside	52.00	871.92	Static
04/10/75	SBVMWD	53.72	870.20	Static
04/16/75	City of Riverside	50.20	873.72	Static
04/30/75	City of Riverside	51.30	872.62	Static
05/06/75	City of Riverside	52.90	871.02	Static
05/13/75	City of Riverside	53.30	870.62	Static
05/15/75	SBVMWD	55.02	868.90	Static
05/22/75	City of Riverside	53.50	870.42	Static
05/27/75	City of Riverside	52.90	871.02	Static
06/10/75	City of Riverside	54.10	869.82	Static
06/11/75	SBVMWD	56.27	867.65	Static
06/17/75	City of Riverside	54.80	869.12	Static
06/24/75	City of Riverside	55.00	868.92	Static
06/25/75	City of Riverside	55.00	868.92	Static
07/01/75	City of Riverside	56.10	867.82	Static
07/09/75	City of Riverside	56.80	867.12	Static
07/10/75	SBVMWD	56.84	867.08	Static

**Western San Bernardino Watermaster
Well Measurement Record for**

Flume #5

State Well Number 1S/4W29Q01S

Basin: Riverside North	Reference Point Elevation:	924.37	
		923.92	A
		917.75	B
		916.53	C

Date	Obtained from	Ref. Pt to Water	Water Surface Elevation	Static	Remarks
07/29/75	City of Riverside	57.60	866.32	Static	
08/08/75	City of Riverside	57.80	866.12	Static	
08/14/75	SBVMWD	55.47	868.45	Static	
08/20/75	City of Riverside	58.30	865.62	Static	
09/12/75	SBVMWD	53.39	870.53	Static	
10/10/75	SBVMWD	49.72	874.20	Static	
11/12/75	SBVMWD	65.44	858.48	Static (Low)	
12/10/75	SBVMWD	65.07	858.85	Static	
1976					
01/15/76	SBVMWD	61.57	862.35	Static	
02/12/76	SBVMWD	63.56	860.36	Static	
03/12/76	SBVMWD	62.83	861.09	Static	
04/16/76	SBVMWD	60.43	863.49	Static	
05/12/76	SBVMWD	58.76	865.16	Static	
06/11/76	City of Riverside	68.70	849.05	Pumping Nearby	B
06/11/76	SBVMWD	62.18	861.74	Static	
06/15/76	City of Riverside	67.20	850.55	Pumping Nearby	B
06/22/76	City of Riverside	68.40	849.35	Pumping Nearby	B
06/30/76	City of Riverside	68.90	848.85	Pumping Nearby	B
07/13/76	City of Riverside	69.40	848.35	Pumping Nearby	B
07/15/76	SBVMWD	74.30	849.62	Static (Low)	
07/20/76	City of Riverside	66.60	851.15	Static	
07/27/76	City of Riverside	65.20	852.55	Static	
08/01/76	City of Riverside	65.20	852.55	Static	
08/10/76	City of Riverside	64.80	852.95	Static	
08/17/76	City of Riverside	65.30	852.45	Static	
08/17/76	SBVMWD	64.94	852.81	Static	
08/24/76	City of Riverside	65.18	852.57	Static	
08/31/76	City of Riverside	66.20	851.55	Static	
09/10/76	SBVMWD	62.83	854.92	Static	
09/14/76	City of Riverside	60.00	857.75	Static	
09/21/76	City of Riverside	49.50	?	Reading Error?	B
10/06/76	City of Riverside	56.50	861.25	Static	
10/12/76	City of Riverside	58.00	859.75	Static	
10/13/76	SBVMWD	65.27	858.65	Static	
10/19/76	City of Riverside	58.20	859.55	Static	
10/26/76	City of Riverside	60.50	857.25	Static	
11/01/76	City of Riverside	60.30	857.45	Static	
11/10/76	City of Riverside	57.70	860.05	Static	

**Western San Bernardino Watermaster
Well Measurement Record for**

Flume #5

State Well Number 1S/4W29Q01S

Basin: Riverside North	Reference Point Elevation:	924.37		
		923.92	A	
		917.75	B	
		916.53	C	

Date	Obtained from	Ref. Pt to Water	Water Surface Elevation	Static	Remarks
11/16/76	City of Riverside	58.90	858.85	Static	
11/18/76	SBVMWD	61.43	856.32	Static	
11/23/76	City of Riverside	57.40	860.35	Static	
12/01/76	City of Riverside	60.10	857.65	Static	
12/07/76	City of Riverside	62.80	854.95	Static	
12/14/76	City of Riverside	63.00	854.75	Static	
12/16/76	SBVMWD	61.63	856.12	Static	
12/21/76	City of Riverside	62.30	855.45	Static	
12/29/76	City of Riverside	61.30	856.45	Static	

1977

01/04/77	City of Riverside	55.70	862.05	Static	
01/12/77	City of Riverside	55.30	862.45	Static	
01/14/77	SBVMWD	61.75	856.00	Static	Ref Point? B
01/18/77	City of Riverside	53.70	864.05	Static	
01/25/77	City of Riverside	54.60	863.15	Static	
02/01/77	City of Riverside	54.10	863.65	Static	
02/08/77	City of Riverside	59.10	858.65	Static	#4 on
02/10/77	SBVMWD	61.65	856.10	Static	
02/15/77	City of Riverside	62.40	855.35	Static	#4 on
02/22/77	City of Riverside	61.30	856.45	Static	#4 on
03/01/77	City of Riverside	51.60	866.15	Reading Error?	B
03/08/77	City of Riverside	60.30	857.45	Static	
03/10/77	SBVMWD	60.49	857.26	Static	
03/15/77	City of Riverside	60.10	857.65	Static	
03/22/77	City of Riverside	60.20	857.55	Static	
03/29/77	City of Riverside	58.30	859.45	Static	
04/01/77	City of Riverside	57.80	859.95	Static	
04/05/77	City of Riverside	57.40	860.35	Static	
04/12/77	City of Riverside	57.40	860.35	Static	
04/13/77	SBVMWD	58.50	859.25	Static	
04/19/77	City of Riverside	57.80	859.95	Static	
04/26/77	City of Riverside	57.40	860.35	Static	
05/01/77	City of Riverside	57.80	859.95	Static	#3 on
05/05/77	City of Riverside	60.90	856.85	Static	#3 on
05/10/77	City of Riverside	54.60	863.15	Static	
05/11/77	SBVMWD	61.44	856.31	Static	Ref Point? B
05/17/77	City of Riverside	54.20	863.55	Static	
05/24/77	City of Riverside	54.50	863.25	Static	
06/02/77	City of Riverside	55.60	862.15	Static	#2 on

**Western San Bernardino Watermaster
Well Measurement Record for**

Flume #5

State Well Number 1S/4W29Q01S

Basin: Riverside North	Reference Point Elevation: 924.37	
	923.92	A
	917.75	B
	916.53	C

Date	Obtained from	Ref. Pt to Water	Water Surface Elevation	Remarks	
06/07/77	City of Riverside	55.90	861.85	Static #2 on	
06/08/77	SBVMWD	55.01	862.74	Static	
06/14/77	City of Riverside	56.40	861.35	Static #2 on	
06/21/77	City of Riverside	57.40	860.35	Static #2 on	
06/28/77	City of Riverside	58.30	859.45	Static #2 on	
07/05/77	City of Riverside	59.00	858.75	Static #2 on	
07/07/77	SBVMWD	61.42	856.33	Static	
07/12/77	City of Riverside	61.80	855.95	Static	
07/19/77	City of Riverside	64.50	853.25	Static	
07/19/77	WMWD	68.50	855.42	Static	
07/26/77	City of Riverside	64.50	853.25	Static	
08/01/77	City of Riverside	65.60	852.15	Static	
08/02/77	City of Riverside	65.30	852.45	Static	
08/08/77	City of Riverside	66.10	851.65	Static	
08/09/77	WMWD	73.20	850.72	Static #6 & 3 on	A
08/16/77	City of Riverside	66.10	851.65	Static	
08/22/77	WMWD	65.20	858.72	Static	
08/23/77	City of Riverside	59.30	858.45	Static	
08/25/77	SBVMWD	59.24	858.51	Static	
08/31/77	City of Riverside	59.30	858.45	Static	
09/01/77	City of Riverside	59.30	858.45	Static	
09/05/77	City of Riverside	59.10	858.65	Static	
09/06/77	WMWD	65.60	858.32	Static #2 on	
09/13/77	City of Riverside	60.00	857.75	Static #2 on	
09/16/77	WMWD	67.20	856.72	Static	
09/20/77	City of Riverside	64.10	853.65	Static #2 on	
09/21/77	SBVMWD	63.97	853.78	Pumping Nearby	B
09/27/77	City of Riverside	63.70	854.05	Static #2 on	
10/01/77	City of Riverside	63.70	854.05	Static #2 on	
10/03/77	WMWD	70.50	853.42	Static	
10/05/77	WMWD	64.00	853.75	Static #2 on	
10/11/77	WMWD	66.40	851.35	Static	
10/11/77	SBVMWD	64.51	853.24	Static	
10/20/77	City of Riverside	68.20	849.55	Static #4 on	
10/25/77	City of Riverside	70.40	847.35	Static #4 on	
11/02/77	City of Riverside	70.50	847.25	Static #4 on	
11/08/77	City of Riverside	71.20	846.55	Static	
11/11/77	WMWD	78.90	845.02	Static #2 on	
11/15/77	SBVMWD	74.99	842.76	Pumping Nearby	B
11/15/77	City of Riverside	73.40	844.35	Pumping #4 on	

**Western San Bernardino Watermaster
Well Measurement Record for**

Flume #5

State Well Number 1S/4W29Q01S

Basin: Riverside North	Reference Point Elevation:	924.37	
		923.92	A
		917.75	B
		916.53	C

Date	Obtained from	Ref. Pt to Water	Water Surface Elevation	Remarks
11/22/77	City of Riverside	74.50	843.25	Pumping #4 on
12/01/77	City of Riverside	73.00	844.75	Pumping #4 on
12/06/77	City of Riverside	74.60	843.15	Pumping #4 on
12/13/77	City of Riverside	73.80	843.95	Pumping #4 on
12/14/77	SBVMWD	74.08	843.67	Pumping Nearby
12/20/77	City of Riverside	74.20	843.55	Pumping #4 on
12/27/77	City of Riverside	72.30	845.45	Pumping (Low)

1978

01/01/78	City of Riverside	72.30	845.45	Static	
01/10/78	City of Riverside	63.10	854.65	Static	
01/14/78	SBVMWD	58.84	858.91	Static	
01/17/78	City of Riverside	53.80	863.95	Static	
01/24/78	City of Riverside	53.20	864.55	Static	
01/31/78	City of Riverside	54.20	863.55	Static	
02/14/78	City of Riverside	47.80	869.95	Static	
02/16/78	SBVMWD	55.39	862.36	Reading Error?	B
02/17/78	WMWD	54.00	869.92	Static	
02/21/78	City of Riverside	48.80	868.95	Static	
02/28/78	City of Riverside	49.80	867.95	Static	
03/14/78	City of Riverside	21.80	895.95	Static	
03/16/78	SBVMWD	20.28	897.47	Static	
03/16/78	WMWD	26.10	897.82	Static	
03/21/78	City of Riverside	18.30	899.45	Static	
03/29/78	City of Riverside	20.40	897.35	Static	
04/05/78	WMWD	22.30	901.62	Static	
04/11/78	SBVMWD	14.62	903.13	Static	
04/11/78	City of Riverside	14.50	903.25	Static	
04/18/78	City of Riverside	14.00	903.75	Static	
04/25/78	City of Riverside	14.20	903.55	Static	
04/27/78	WMWD	20.30	903.42	Static	
05/10/78	SBVMWD	13.55	904.20	Static	
05/10/78	City of Riverside	13.60	904.15	Static	
05/17/78	City of Riverside	13.60	904.15	Static	
05/25/78	City of Riverside	14.00	903.75	Static	
06/07/78	City of Riverside	13.70	904.05	Static	
06/13/78	City of Riverside	14.10	903.65	Static	
06/13/78	WMWD	20.00	903.92	Static	
06/14/78	SBVMWD	14.48	903.27	Static	
06/20/78	City of Riverside	13.40	904.35	Static	

**Western San Bernardino Watermaster
Well Measurement Record for**

Flume #5

State Well Number 1S/4W29Q01S

Basin: Riverside North	Reference Point Elevation:	924.37	
		923.92	A
		917.75	B
		916.53	C

Date	Obtained from	Ref. Pt to Water	Water Surface Elevation	Remarks
06/28/78	City of Riverside	13.90	903.85	Static
07/04/78	City of Riverside	14.60	903.15	Static
07/11/78	SBVMWD	17.20	900.55	Static
07/11/78	City of Riverside	17.90	899.85	Static
08/01/78	City of Riverside	19.10	898.65	Static
08/01/78	WMWD	24.50	899.42	Static
08/08/78	City of Riverside	18.10	899.65	Static
08/09/78	SBVMWD	18.05	899.70	Static
08/15/78	City of Riverside	18.00	899.75	Static
08/24/78	City of Riverside	15.50	902.25	Static
08/29/78	City of Riverside	20.30	897.45	Static
09/04/78	City of Riverside	21.30	896.45	Static
09/12/78	City of Riverside	22.50	895.25	Static
09/13/78	SBVMWD	20.10	897.65	Static
09/13/78	WMWD	28.00	895.92	Static
09/20/78	City of Riverside	22.80	894.95	Static
09/26/78	City of Riverside	22.80	894.95	Static
10/01/78	City of Riverside	24.50	893.25	Static
10/09/78	City of Riverside	26.00	891.75	Static
10/11/78	SBVMWD	26.34	891.41	Static
10/17/78	City of Riverside	26.80	890.95	Static
10/24/78	City of Riverside	27.20	890.55	Static
10/26/78	WMWD	34.70	889.22	Static
11/06/78	City of Riverside	29.70	888.05	Static (Low)
11/14/78	City of Riverside	26.40	891.35	Static (Low)
11/15/78	SBVMWD	30.95	886.80	Pumping Nearby B
11/21/78	City of Riverside	25.30	892.45	Static
11/28/78	City of Riverside	25.00	892.75	Static
12/05/78	City of Riverside	22.10	895.65	Static
12/13/78	SBVMWD	25.05	892.70	Pumping Nearby B
12/19/78	City of Riverside	20.40	897.35	Static
12/27/78	City of Riverside	19.80	897.95	Static
1979				
01/03/79	City of Riverside	19.80	897.95	Static
01/09/79	City of Riverside	19.80	897.95	Static
01/16/79	City of Riverside	19.50	898.25	Static
01/17/79	SBVMWD	20.15	897.60	Static
01/30/79	City of Riverside	19.60	898.15	Static
02/05/79	WMWD	25.40	898.52	Static

**Western San Bernardino Watermaster
Well Measurement Record for**

Flume #5

State Well Number 1S/4W29Q01S

Basin: Riverside North	Reference Point Elevation:	924.37	
		923.92	A
		917.75	B
		916.53	C

Date	Obtained from	Ref. Pt to Water	Water Surface Elevation	Remarks
02/06/79	City of Riverside	17.90	899.85	Reading Error? B
02/14/79	City of Riverside	18.10	899.65	Static
02/15/79	SBVMWD	18.75	899.00	Static
02/20/79	City of Riverside	18.20	899.55	Static
03/01/79	City of Riverside	16.30	901.45	Static
03/07/79	WMWD	23.60	900.32	Static
03/07/79	City of Riverside	17.10	900.65	Static
03/14/79	City of Riverside	18.10	899.65	Static
03/14/79	SBVMWD	17.60	900.15	Static
03/20/79	City of Riverside	18.00	899.75	Static
03/27/79	City of Riverside	15.20	902.55	Static
04/03/79	City of Riverside	13.80	903.95	Static
04/10/79	City of Riverside	14.70	903.05	Static
04/11/79	SBVMWD	20.30	897.45	Reading Error? B
04/18/79	City of Riverside	13.80	903.95	Static
04/25/79	City of Riverside	12.90	904.85	Static
05/03/79	City of Riverside	13.10	904.65	Static
05/16/79	SBVMWD	13.10	904.65	Static
05/22/79	WMWD	20.00	903.92	Static
05/22/79	City of Riverside	13.70	904.05	Static
05/29/79	City of Riverside	14.30	903.45	Static
06/01/79	City of Riverside	14.30	903.45	Static
06/05/79	City of Riverside	15.90	901.85	Static
06/11/79	SBVMWD	15.05	902.70	Static
06/12/79	City of Riverside	18.20	899.55	Static
06/19/79	City of Riverside	18.80	898.95	Static
06/26/79	City of Riverside	19.20	898.55	Static
07/03/79	City of Riverside	20.70	897.05	Static
07/10/79	City of Riverside	21.40	896.35	Static
07/11/79	SBVMWD	20.55	897.20	Static
08/01/79	City of Riverside	18.80	898.95	Static
08/08/79	SBVMWD	22.80	894.95	Static
08/14/79	City of Riverside	18.90	898.85	Static
08/21/79	WMWD	30.40	893.52	Static
08/28/79	City of Riverside	24.80	892.95	Static
09/05/79	City of Riverside	26.10	891.65	Static
09/13/79	SBVMWD	27.80	889.95	Static
10/11/79	SBVMWD	28.35	889.40	Static
10/16/79	City of Riverside	28.50	889.25	Low
10/23/79	City of Riverside	26.80	890.95	Static

**Western San Bernardino Watermaster
Well Measurement Record for**

Flume #5

State Well Number 1S/4W29Q01S

Basin: Riverside North	Reference Point Elevation:	924.37	
		923.92	A
		917.75	B
		916.53	C

Date	Obtained from	Ref. Pt to Water	Water Surface Elevation	Remarks
10/30/79	City of Riverside	25.70	892.05	Static
11/06/79	City of Riverside	25.60	892.15	Static
11/13/79	City of Riverside	25.80	891.95	Static
11/15/79	SBVMWD	28.20	889.55	Static
11/16/79	WMWD	34.10	889.82	Static
11/21/79	City of Riverside	26.00	891.75	Static
11/27/79	City of Riverside	26.00	891.75	Static
12/17/79	SBVMWD	26.90	890.85	Static
1980				1)River flowing around well
01/18/80	WMWD	31.50	892.42	Static
01/21/80	SBVMWD	25.49	892.26	Static
02/04/80	WMWD	29.30	894.62	Static
02/14/80	SBVMWD	22.68	895.07	Static
03/19/80	SBVMWD	12.22	905.53	Static
04/08/80	WMWD	18.20	905.72	Static
08/13/80	WMWD	19.00	904.92	Static
09/05/80	WMWD	19.40	904.52	Static
11/03/80	WMWD	21.20	902.72	Low
12/23/80	WMWD	19.50	904.42	Static
1981				2)River flowing next to well
02/24/81	WMWD	19.40	904.52	Static
05/07/81	WMWD	20.34	903.58	Static
07/10/81	WMWD	22.30	901.62	Static
08/18/81	WMWD	22.00	901.92	Low
12/22/81	WMWD	19.48	904.44	Static
1982				R.P. C=916.53
05/11/82	WMWD	18.80	905.12	Static
05/18/82	City of Riverside	9.60	906.93	Static
05/25/82	City of Riverside	9.30	907.23	Static
06/01/82	City of Riverside	9.10	907.43	Static
06/08/82	City of Riverside	10.00	906.53	Static
06/22/82	City of Riverside	10.10	906.43	Static
07/01/82	City of Riverside	10.60	905.93	Static
07/06/82	City of Riverside	10.70	905.83	Static
07/13/82	City of Riverside	10.90	905.63	Static
07/20/82	City of Riverside	11.10	905.43	Static
08/01/82	City of Riverside	11.40	905.13	Static

**Western San Bernardino Watermaster
Well Measurement Record for**

Flume #5

State Well Number 1S/4W29Q01S

Basin: Riverside North	Reference Point Elevation:	924.37	
		923.92	A
		917.75	B
		916.53	C

Date	Obtained from	Ref. Pt to Water	Water Surface Elevation	Remarks
08/03/82	City of Riverside	11.30	905.23	Static
08/17/82	City of Riverside	12.00	904.53	Static
08/25/82	City of Riverside	12.50	904.03	Low
09/01/82	City of Riverside	12.20	904.33	Static
09/08/82	City of Riverside	12.40	904.13	Static
09/14/82	City of Riverside	12.00	904.53	Static
09/21/82	City of Riverside	11.40	905.13	Static
10/01/82	City of Riverside	10.70	905.83	Static
10/05/82	City of Riverside	10.80	905.73	Static
10/19/82	City of Riverside	11.30	905.23	Static
10/26/82	City of Riverside	10.80	905.73	Static
11/02/82	City of Riverside	11.30	905.23	Static
11/09/82	City of Riverside	12.00	904.53	Static
11/16/82	City of Riverside	10.20	906.33	Static
11/23/82	City of Riverside	9.80	906.73	Static
12/14/82	City of Riverside	10.10	906.43	Static
12/27/82	WMWD	9.30	907.23	Static

1983

01/13/83	City of Riverside	9.70	906.83	
01/14/83	City of Riverside	9.70	906.83	
01/18/83	City of Riverside	9.90	906.63	Low
02/01/83	City of Riverside	8.70	907.83	
02/15/83	City of Riverside	9.10	907.43	
02/22/83	City of Riverside	9.40	907.13	
09/01/83	WMWD	9.10	907.43	
09/07/83	City of Riverside	9.40	907.13	
09/13/83	City of Riverside	9.30	907.23	
09/20/83	City of Riverside	9.30	907.23	
09/27/83	City of Riverside	9.30	907.23	
11/01/83	WMWD	8.30	908.23	
11/20/83	City of Riverside	9.80	906.73	

1984

05/15/84	City of Riverside	9.00	907.53	
08/01/84		9.40	907.13	
10/02/84	WMWD	9.30	907.23	Low

**Western San Bernardino Watermaster
Well Measurement Record for**

Flume #5

State Well Number 1S/4W29Q01S

Basin: Riverside North Reference Point Elevation: 916.53
 Reference Point #2 Elevation: 913.22
 Reference Point #3 Elevation: 913.53
Reference Point #4 Elevation: 913.448
 Reference Point #4a Elevation: 914.622
 Reference Point #5 Elevation: 916.04 see note in comment box

Date	Obtained from	Ref. Pt to Water	Water Surface Elevation	Remarks
1985				
12/31/85	WMWD	-	-	Well not measured
1986				
10/24/86	WMWD	11.50	905.03	Low
1987				
04/20/87	Western MWD	13.50	903.03	Low for the year
12/23/87	Western MWD	13.40	903.13	
1988				
04/04/88	Western MWD	14.00	902.53	Low for the year
1989				
06/12/89	City of Riverside	25.00	891.53	Low for the year
1990				
01/25/90	City of Riverside	33.50	883.03	
02/03/90	City of Riverside	32.00	884.53	
02/10/90	City of Riverside	33.00	883.53	
02/24/90	City of Riverside	29.00	887.53	
03/07/90	City of Riverside	29.00	887.53	
03/12/90	City of Riverside	28.00	888.53	
05/22/90	Western MWD	32.50	884.03	
07/09/90	City of Riverside	34.40	882.13	
08/03/90	City of Riverside	35.80	880.73	
09/19/90	City of Riverside	34.10	882.43	
10/31/90	City of Riverside	33.30	883.23	
12/02/90	City of Riverside	50.00	866.53	?
12/12/90	Western MWD	39.80	876.73	Low for the year
1991				
01/15/91	City of Riverside	39.50	877.03	
01/28/91	City of Riverside	39.50	877.03	
05/31/91	Western MWD	37.75	878.78	Low for the year
1992				
01/16/92	Western MWD	49.70	866.83	
02/05/92	City of Riverside	44.30	872.23	
11/25/92	City of Riverside	52.50	864.03	
12/15/92	City of Riverside	59.00	857.53	Low for the year
1993				
01/25/93	City of Riverside	20.30	896.23	
10/26/93	City of Riverside	12.50	904.03	Low for the year
12/28/93	City of Riverside	10.00	906.53	
1994				
01/03/94	Western MWD	9.25	907.28	
05/31/94	Western MWD	8.10	908.43	

**Western San Bernardino Watermaster
Well Measurement Record for**

Flume #5

State Well Number 1S/4W29Q01S

Basin: Riverside North Reference Point Elevation: 916.53
 Reference Point #2 Elevation: 913.22
 Reference Point #3 Elevation: 913.53
Reference Point #4 Elevation: 913.448
 Reference Point #4a Elevation: 914.622
 Reference Point #5 Elevation: 916.04 see note in comment box

Date	Obtained from	Ref. Pt to Water	Water Surface Elevation	Remarks
------	---------------	------------------	-------------------------	---------

11/24/94	City of Riverside	10.10	906.43	
12/06/94	Western MWD	10.10	906.43	Low for the year
12/21/94	City of Riverside	25.00	891.53	?

1995

05/24/95	Western MWD	6.00	910.53	Low for the year
-----------------	--------------------	-------------	---------------	-------------------------

1996

03/04/96	Western MWD	6.40	910.13	
04/12/96	Western MWD/SBVMWD	12.60	903.93	Rix startup
04/30/96	City of Riverside	16.00	900.53	#6 pumping
05/10/96	Western MWD	18.65	897.88	#2 & #6 pumping
05/14/96	SBVMWD	19.45	897.08	#2 & #6 pumping
05/28/96	City of Riverside	16.00	900.53	#6 pumping
06/14/96	SBVMWD	25.15	891.38	#2 & #6 pumping
07/05/96	Western MWD	27.70	888.83	#2 & #6 pumping
07/19/96	SBVMWD	29.40	887.13	#6 pumping
08/06/96	Western MWD	31.50	885.03	#2 & #6 pumping
08/20/96	SBVMWD	32.50	884.03	#2 & #6 pumping
10/16/96	SBVMWD	36.10	880.43	#2 pumping
11/04/96	Western MWD	36.60	879.93	#2 & #6 pumping
11/18/96	SBVMWD	38.90	877.63	#2 & #6 pumping
12/09/96	Western MWD	36.00	880.53	#2 & #6 pumping
12/17/96	SBVMWD	28.90	887.63	Low for the year

1997

01/16/97	SBVMWD	-	-	River flowing
01/16/97	SBVMWD	-	-	River flowing
02/19/97	SBVMWD	16.90	899.63	
03/18/97	SBVMWD	20.50	896.03	
04/18/97	SBVMWD	27.30	889.23	#2 & #6 pumping
05/05/97	Western MWD	29.80	886.73	#2 & #6 pumping
05/20/97	SBVMWD	28.60	887.93	#2 & #6 pumping
06/17/97	SBVMWD	35.40	881.13	#2 & #6 pumping
07/16/97	SBVMWD	38.50	878.03	#2 & #6 pumping
09/16/97	SBVMWD	43.40	873.13	#6 pumping
10/16/97	SBVMWD	43.10	873.43	#6 pumping
11/18/97	SBVMWD	41.60	874.93	#2 pumping
12/16/97	SBVMWD	34.75	881.78	
12/29/97	Western MWD	36.95	879.58	Low for the year

1998

02/19/98	SBVMWD	11.90	904.63	
04/20/98	SBVMWD	7.95	908.58	
06/01/98	Western MWD	6.55	909.98	River just to east
06/18/98	SBVMWD	7.25	909.28	
07/14/98	SBVMWD	8.65	907.88	
08/05/98	City of Riverside	13.30	903.23	#2 & #6 pumping
08/17/98	SBVMWD	7.60	908.93	
09/17/98	SBVMWD	8.40	908.13	

**Western San Bernardino Watermaster
Well Measurement Record for**

Flume #5

State Well Number 1S/4W29Q01S

Basin: Riverside North Reference Point Elevation: 916.53
 Reference Point #2 Elevation: 913.22
 Reference Point #3 Elevation: 913.53
Reference Point #4 Elevation: 913.448
 Reference Point #4a Elevation: 914.622
 Reference Point #5 Elevation: 916.04 see note in comment box

Date	Obtained from	Ref. Pt to Water	Water Surface Elevation	Remarks
------	---------------	------------------	-------------------------	---------

11/10/98	SBVMWD	16.40	900.13	
12/18/98	SBVMWD	18.00	898.53	Low for the year

1999

01/09/99	City of Riverside	19.20	897.33	#2 on, #6 on
01/18/99	Western MWD	18.50	898.03	
01/19/99	SBVMWD	16.50	900.03	#2 off, #6 off
02/16/99	SBVMWD	11.30	905.23	#2 off, #6 off
03/17/99	SBVMWD	15.30	901.23	#2 off, #6 off
04/14/99	SBVMWD	11.60	904.93	#2 off, #6 off
05/12/99	SBVMWD	15.24	901.29	#2 on, #6 on
05/19/99	City of Riverside	17.80	898.73	#2 on, #6 on
06/03/99	Western MWD	16.75	899.78	#2 on, #6 on
06/04/99	SBVMWD	17.06	899.47	#2 on, #6 on
06/16/99	SBVMWD	18.10	898.43	#2 on, #6 on
07/13/99	SBVMWD	19.74	896.79	#2 on, #6 off
07/27/99	City of Riverside	21.80	894.73	#2 off, #6 off/low
08/17/99	SBVMWD	20.90	895.63	#2 off, #6 on
09/14/99	SBVMWD	26.00	890.53	#2 on, #6 on
10/07/99	City of Riverside	27.00	889.53	#2 on, #6 on
10/15/99	SBVMWD	27.30	889.23	#2 on, #6 on
11/17/99	SBVMWD	28.40	888.13	#2 on, #6 on
12/14/99	SBVMWD	28.62	887.91	#2 on, #6 on
12/28/99	Western MWD	28.30	888.23	#2 on, #6 on

2000

01/14/00	City of Riverside	26.8	889.73	#2 on, #6 on
01/14/00	SBVMWD	27.82	888.71	#2 on, #6 on
02/14/00	SBVMWD	21.00	895.53	#2 off, #6 off
03/13/00	SBVMWD	12.90	903.63	#2 off, #6 off
03/21/00	City of Riverside	16.40	900.13	
04/12/00	SBVMWD	23.80	892.73	#2 on, #6 on
05/09/00	Western MWD	25.33	891.20	#2 on, #6 on
05/12/00	SBVMWD	25.40	891.13	#2 on, #6 on
06/13/00	SBVMWD	29.00	887.53	#2 on, #6 on
07/13/00	SBVMWD	34.06	882.47	#2 on, #6 on
08/14/00	SBVMWD	35.92	880.61	#2 off, #6 off/low
09/15/00	SBVMWD	39.88	876.65	#2 on, #6 on
09/18/00	City of Riverside	38.50	878.03	#6 on
10/16/00	SBVMWD	41.70	874.83	#2 on, #6 on
11/16/00	SBVMWD	42.30	874.23	#2 on, #6 on
12/04/00	City of Riverside	43.70	872.83	#2 on, #6 on
12/18/00	SBVMWD	44.36	872.17	#2 on, #6 on

2001

01/17/01	SBVMWD	34.66	881.87	#2 off, #6 off
01/19/01	City of Riverside	41.40	875.13	#2 off, #6 off
02/16/01	SBVMWD	30.30	886.23	#2 off, #6 off
02/19/01	City of Riverside	34.50	882.03	#2 off, #6 off

**Western San Bernardino Watermaster
Well Measurement Record for**

Flume #5

State Well Number 1S/4W29Q01S

Basin: Riverside North Reference Point Elevation: 916.53
 Reference Point #2 Elevation: 913.22
 Reference Point #3 Elevation: 913.53
Reference Point #4 Elevation: 913.448
 Reference Point #4a Elevation: 914.622
 Reference Point #5 Elevation: 916.04 see note in comment box

Date	Obtained from	Ref. Pt to Water	Water Surface Elevation	Remarks
03/09/01	Western MWD	29.96	886.57	
03/16/01	SBVMWD	33.10	883.43	#2 off, #6 off
04/18/01	SBVMWD	34.94	881.59	#2 off, #6 off
04/23/01	City of Riverside	32.30	884.23	#2 off, #6 off
05/18/01	SBVMWD	36.90	879.63	#2 off, #6 off
06/08/01	Western MWD	36.45	880.08	
06/18/01	SBVMWD	39.90	876.63	#2 off, #6 off
06/18/01	SBVMWD	36.90	879.63	#2 off, #6 off
07/18/01	SBVMWD	38.86	877.67	#2 off, #6 off
08/20/01	SBVMWD	41.48	875.05	#2 off, #6 off
09/24/01	SBVMWD	46.60	869.93	#2 off, #6 off
10/16/01	SBVMWD	48.90	867.63	#2 off, #6 off
11/14/01	SBVMWD	49.50	867.03	#2 off, #6 off
11/16/01	Western MWD	50.80	865.73	#2 on, #6 off
12/04/01	City of Riverside	47.50	869.03	#2 off, #6 off/LOW
12/17/01	SBVMWD	46.34	870.19	#2 off, #6 off
2002				
01/12/02	City of Riverside	48.10	868.43	#2 off, #6 off
01/17/02	SBVMWD	47.10	869.43	#2 off, #6 off
02/14/02	City of Riverside	47.60	868.93	#6 off
02/15/02	SBVMWD	47.80	868.73	#2 off, #6 off
03/18/02	SBVMWD	47.10	869.43	#2 off, #6 off
03/28/02	City of Riverside	60.70	855.83	#2 off, #6 off, ?
04/15/02	SBVMWD	48.54	867.99	#2 off, #6 off
05/01/02	Western MWD	49.90	866.63	
05/03/02	City of Riverside	62.40	854.13	#2 off, #6 off
05/16/02	SBVMWD	49.70	866.83	#2 off, #6 off
06/11/02	City of Riverside	52.50	864.03	Static
06/14/02	SBVMWD	51.64	864.89	#2 off, #6 off
07/10/02	SBVMWD	55.82	860.71	#2 off, #6 on
08/14/02	SBVMWD	58.50	858.03	#2 off, #6 on
09/13/02	SBVMWD	61.00	855.53	#2 off, #6 on
09/19/02	City of Riverside	71.40	845.13	#2 on, #6 on
10/16/02	SBVMWD	63.14	853.39	#2 on, #6 on
11/14/02	City of Riverside	57.00	859.53	#2 off, #6 off
11/16/02	Western MWD	--	--	#2 pumping
11/22/02	SBVMWD	57.80	858.73	#2 off, #6 off, LOW
12/11/02	Western MWD	56.55	859.98	
12/18/02	SBVMWD	55.60	860.93	#2 off, #6 off
12/20/02	City of Riverside	57.30	859.23	#2 off, #6 off
2003				
01/13/03	SBVMWD	56.50	860.03	#2 off, #6 off
02/13/03	SBVMWD	53.80	862.73	#2 off, #6 off
03/05/03	City of Riverside	52.20	864.33	
03/26/03	SBVMWD	47.80	868.73	#2 off, #6 off
04/15/03	SBVMWD	45.90	870.63	#2 off, #6 off
05/08/03	SBVMWD	47.85	868.68	#2 on, #6 off

**Western San Bernardino Watermaster
Well Measurement Record for**

Flume #5

State Well Number 1S/4W29Q01S

Basin: Riverside North Reference Point Elevation: 916.53
 Reference Point #2 Elevation: 913.22
 Reference Point #3 Elevation: 913.53
Reference Point #4 Elevation: 913.448
 Reference Point #4a Elevation: 914.622
 Reference Point #5 Elevation: 916.04 see note in comment box

Date	Obtained from	Ref. Pt to Water	Water Surface Elevation	Remarks
05/09/03	WMWD	46.38	870.15	#2 on, #6 off
06/18/03	SBVMWD	51.65	864.88	#2 off, #6 off
07/17/03	SBVMWD	56.70	859.83	#2 off, #6 on
08/13/03	SBVMWD	58.10	858.43	#2 off, #6 on
08/20/03	City of Riverside	60.00	856.53	
09/12/03	SBVMWD	61.10	855.43	#2 off, #6 on
10/24/03	SBVMWD	65.50	851.03	#2 off, #6 on
11/14/03	SBVMWD	63.00	853.53	#2 off, #6 off / LOW
11/19/03	City of Riverside	62.00	854.53	#2 off, #6 off
12/08/03	WMWD	61.93	854.60	#2 off, #6 off
12/17/03	SBVMWD	61.90	854.63	#2 off, #6 off
12/22/03	City of Riverside	61.90	854.63	
2004				
01/21/04	SBVMWD	62.20	854.33	#2 off, #6 off
02/23/04	SBVMWD	61.00	855.53	#2 off, #6 off
03/11/04	City of Riverside	60.10	856.43	
03/25/04	SBVMWD	60.25	856.28	#2 off, #6 off
04/16/04	SBVMWD	60.25	856.28	#2 off, #6 off
05/01/04	City of Riverside	62.50	854.03	
05/04/04	WMWD	60.30	856.23	#2 off, #6 off
05/12/04	City of Riverside	60.90	855.63	
05/13/04	SBVMWD	60.80	855.73	#2 off, #6 off
06/15/04	City of Riverside	63.50	853.03	Date estimated
06/15/04	SBVMWD	62.20	854.33	#2 off, #6 off
07/15/04	City of Riverside	63.60	852.93	Date estimated
07/15/04	SBVMWD	64.60	851.93	#2 off, #6 off
08/19/04	SBVMWD	65.30	851.23	#2 off, #6 off
09/15/04	City of Riverside	63.50	853.03	Date estimated
09/20/04	SBVMWD	67.30	849.23	#2 off, #6 off /LOW
10/18/04	SBVMWD	66.50	850.03	#2 off, #6 off
11/15/04	WMWD	59.85	856.68	
11/15/04	SBVMWD	61.00	855.53	#2 off, #6 off
12/16/04	City of Riverside	60.00	856.53	
12/16/04	SBVMWD	60.00	856.53	#2 off, #6 off
2005				
01/15/05	C of R	-	-	Flooded
01/18/05	SBVMWD	32.80	883.73	flooded
02/28/05	SBVMWD	19.10	897.43	#2 off, #6 off
03/21/05	SBVMWD	13.00	903.53	#2 off, #6 off
04/15/05	C of R	24.90	891.63	#2 unkn #3 off, #4 off, #6 off
04/18/05	SBVMWD	10.50	906.03	#2 off, #6 off
04/21/05	WMWD	10.35	906.18	#2 off, #6 off
04/27/05	C of R	24.90	891.63	Static
05/13/05	SBVMWD	9.30	907.23	#2 off, #6 off
05/27/05	WMWD	9.58	906.95	#2 off
06/14/05	SBVMWD	9.75	906.78	#2 off, #6 off
06/15/05	C of R	9.80	906.73	Static
07/14/05	SBVMWD	9.50	907.03	#2 off, #6 off

**Western San Bernardino Watermaster
Well Measurement Record for**

Flume #5

State Well Number 1S/4W29Q01S

Basin: Riverside North Reference Point Elevation: 916.53
 Reference Point #2 Elevation: 913.22
 Reference Point #3 Elevation: 913.53
Reference Point #4 Elevation: 913.448
 Reference Point #4a Elevation: 914.622
 Reference Point #5 Elevation: 916.04 see note in comment box

Date	Obtained from	Ref. Pt to Water	Water Surface Elevation	Remarks
07/15/05	C of R	6.00	910.53	#2 off, #3 off, #4 off, #6 off
08/14/05	SBVMWD	8.80	907.73	#2 off, #6 off
09/19/05	SBVMWD	15.10	901.43	#2 off, #3 on, #4 on, #6 on
10/10/05	WMWD	21.95	894.58	#4 on, #6 on
10/19/05	SBVMWD	16.20	900.33	#2 on, #3 on, #4 off, #6 off
11/04/05	WMWD	26.52	890.01	#3 on, #4 on, #6 on
11/05/05	C of R	22.80	893.73	#2 on, #3 on, #4 off, #6 off / Low
11/28/05	SBVMWD	30.20	886.33	#2 on, #3 on, #4 off, #6 on
12/12/05	WMWD	33.01	883.52	#2 on, #3 on, #6 on
12/13/05	SBVMWD	33.12	883.41	#2 on, #3 on, #4 off, #6 on
2006				
01/09/06	WMWD	28.49	888.04	#2 on, #3 on, #4 off, #6 off
01/11/06	SBVMWD	31.00	885.53	#2 on, #3 on, #4 off, #6 on
02/13/06	WMWD	35.67	880.86	#2 on, #3 on, #4 off, #6 off
02/14/06	SBVMWD	35.86	880.67	#2 on, #3 on, #4 off, #6 off
03/13/06	WMWD	25.22	891.31	#2 off, #3 off, #4 off, #6 off
03/22/06	SBVMWD	23.35	893.18	#2 off, #3 off, #4 off, #6 off
04/10/06	SBVMWD	13.20	903.33	#2 off, #3 off, #4 off, #6 off
04/10/06	WMWD	13.17	903.36	#2 off, #3 off, #4 off, #6 off
05/08/06	WMWD	13.46	903.07	#2 on, #3 on, #4 off, #6 off
05/12/06	SBVMWD	12.90	903.63	#2 on, #3 on, #4 off, #6 on
06/10/06	WMWD	24.52	892.01	#2 on, #3 on, #4 off, #6 on
06/13/06	SBVMWD	25.50	891.03	#2 on, #3 on, #4 off, #6 on
07/11/06	WMWD	32.84	883.69	#2 on, #3 on, #4 off, #6 on
07/13/06	SBVMWD	33.40	883.13	#2 on, #3 on, #4 off, #6 off
08/14/06	WMWD	39.61	876.92	#2 on, #3 on, #4 on, #6 off
08/20/06	SBVMWD	42.15	874.38	#2 on, #3 on, #4 on, #6 off
09/11/06	WMWD	44.76	871.77	#2 on, #3 on, #4 on, #6 off
09/25/06	SBVMWD	45.25	871.28	#2 on, #3 on, #4 on, #6 off
10/04/06	C of R	44.60	871.93	#2 off, #3 off, #4 off, #6 off / LOW
10/09/06	WMWD	43.46	873.07	#2 off, #3 off, #4 off, #6 off
10/25/06	SBVMWD	45.40	871.13	#2 on, #3 on, #4 on, #6 off
11/13/06	WMWD	49.25	867.28	#2 on, #3 on, #4 on, #6 off
11/21/06	SBVMWD	50.60	865.93	#2 on, #3 on, #4 on, #6 off
12/11/06	WMWD	54.29	862.24	#2 off, #3 on, #4 on, #6 on
12/21/06	SBVMWD	51.85	864.68	#2 on, #3 on, #4 off, #6 off
2007				
01/08/07	WMWD	48.04	868.49	#2 off, #3 off, #4 off, #6 off
01/14/07	C of R	47.50	869.03	
01/22/07	SBVMWD	48.00	868.53	#2 off, #3 off, #4 off, #6 off
02/01/07	WMWD	46.70	869.83	#2 off, #3 off, #4 off, #6 off
02/15/07	SBVMWD	48.20	868.33	#2 off, #3 off, #4 off, #6 off
02/21/07	C of R	45.00	871.53	
03/12/07	WMWD	44.64	871.89	
03/23/07	SBVMWD	47.70	868.83	#2 off, #3 off, #4 off, #6 off
04/11/07	WMWD	45.87	870.66	
04/12/07	C of R	54.00	869.92	
04/27/07	SBVMWD	44.90	871.63	#2 off, #3 off, #4 off, #6 off

**Western San Bernardino Watermaster
Well Measurement Record for**

Flume #5

State Well Number 1S/4W29Q01S

Basin: Riverside North Reference Point Elevation: 916.53
 Reference Point #2 Elevation: 913.22
 Reference Point #3 Elevation: 913.53
Reference Point #4 Elevation: 913.448
 Reference Point #4a Elevation: 914.622
 Reference Point #5 Elevation: 916.04 see note in comment box

Date	Obtained from	Ref. Pt to Water	Water Surface Elevation	Remarks
05/14/07	WMWD	46.31	870.22	
05/16/07	C of R	46.00	870.53	
05/25/07	SBVMWD	45.90	870.63	#2 off, #3 off, #4 off, #6 off
06/09/07	C of R	59.10	864.82	
06/11/07	WMWD	47.83	868.70	#2 off, #3 off, #4 off, #6 off
06/14/07	SBVMWD	48.00	868.53	#2 off, #3 off, #4 off, #6 off
07/10/07	C of R	59.80	864.12	
07/11/07	WMWD	49.02	867.51	#2 off, #3 off, #4 off, #6 off
07/19/07	SBVMWD	49.40	867.13	#2 off, #3 off, #4 off, #6 off
08/09/07	C of R	62.00	861.92	
08/13/07	WMWD	50.64	865.89	#2 off, #3 off, #4 off, #6 off
08/16/07	SBVMWD	50.90	865.63	#2 off, #3 off, #4 off, #6 off
09/10/07	WMWD	51.27	865.26	#2 off, #3 off, #4 off, #6 off
09/14/07	C of R	60.00	863.92	
09/17/07	SBVMWD	51.50	865.03	#2 off, #3 off, #4 off, #6 off
10/08/07	WMWD	52.63	863.90	#2 off, #3 off, #4 off, #6 off
10/26/07	SBVMWD	46.20	870.33	#2 off, #3 off, #4 off, #6 off
11/19/07	SBVMWD	53.50	863.03	#2 off, #3 off, #4 off, #6 off /LOW
11/28/07	WMWD	52.44	864.09	#2 off, #3 off, #4 off, #6 off
12/13/07	SBVMWD	44.80	871.73	#2 off, #3 off, #4 off, #6 off
12/21/07	C of R	47.00	869.53	

2008

01/14/08	City of Riverside	39.04	874.18	
01/14/08	SBVMWD	39.00	874.22	#2 off, #3 off, #4 off, #6 off
01/16/08	Watermaster	39.74	873.48	#2 off, #3 off, #4 off, #6 off
02/06/08	City of Riverside	29.21	884.01	
02/28/08	SBVMWD	27.10	886.12	#2 off, #3 off, #4 off, #6 off
03/19/08	Watermaster	37.40	875.82	#2 off, #3 off, #4 off, #6 off
03/20/08	SBVMWD	36.30	876.92	#2 off, #3 off, #4 off, #6 off
04/02/08	Watermaster	40.89	872.33	#2 off, #3 off, #4 off, #6 off
04/18/08	SBVMWD	41.40	871.82	#2 off, #3 off, #4 off, #6 off
05/02/08	City of Riverside	42.37	870.85	
05/07/08	Watermaster	42.91	870.31	#2 off, #3 off, #4 off, #6 off
05/27/08	SBVMWD	40.50	872.72	#2 on, #3 off, #4 off, #6 off
05/29/08	City of Riverside	43.52	869.70	
06/05/08	Watermaster	48.16	865.06	#2 on, #3 off, #4 off, #6 on
06/16/08	City of Riverside	53.27	859.95	
06/30/08	SBVMWD	47.20	866.02	#2 on, #3 on #4 on #6 on
07/02/08	Watermaster	56.99	856.23	#2 on, #3 on #4 on #6 on
07/30/08	SBVMWD	56.10	857.12	#2 off, #3 off, #4 off, #6 off
08/06/08	Watermaster	60.54	852.68	#2 on, #3 on #4 on #6 on
08/15/08	SBVMWD	64.00	849.22	#2 on, #3 on #4 on #6 on
09/03/08	Watermaster	68.01	845.21	
09/08/08	Watermaster	68.54	844.68	#2 on, #3 on #4 on #6 on
09/16/08	SBVMWD	69.40	843.82	#2 on, #3 on #4 on #6 on
09/30/08	City of Riverside	70.26	842.96	
10/01/08	City of Riverside	69.25	843.97	
10/01/08	Watermaster	69.26	843.96	#2 off, #3 off #4 off #6 off/LOW
10/24/08	SBVMWD	75.80	837.42	#2 on, #3 on #4 on #6 on

**Western San Bernardino Watermaster
Well Measurement Record for**

Flume #5

State Well Number 1S/4W29Q01S

Basin: Riverside North Reference Point Elevation: 916.53
 Reference Point #2 Elevation: 913.22
 Reference Point #3 Elevation: 913.53
Reference Point #4 Elevation: 913.448
 Reference Point #4a Elevation: 914.622
 Reference Point #5 Elevation: 916.04 see note in comment box

Date	Obtained from	Ref. Pt to Water	Water Surface Elevation	Remarks
11/06/08	Watermaster	76.85	836.37	#2 on, #3 on #4 on #6 on
11/20/08	City of Riverside	78.63	834.59	
11/24/08	SBVMWD	79.10	834.12	#2 on, #3 on #4 on #6 on
12/04/08	Watermaster	75.85	837.37	#2 on, #3 on #4 on #6 on
12/16/08	SBVMWD	75.30	837.92	#2 on, #3 on #4 on #6 off
2009				
01/08/09	Watermaster	64.89	848.33	#2 on, #3 on, #4 on, #6 on
01/14/09	SBVMWD	62.35	850.87	#2 off, #3 off, #4 off, #6 off
01/19/09	City of Riverside	61.90	851.32	
01/20/09	City of Riverside	62.11	851.11	Colton pump test
01/21/09	City of Riverside	62.20	851.02	Colton pump test
01/25/09	City of Riverside	61.00	852.22	
02/04/09	Watermaster	57.66	855.56	#2 off, #3 off, #4 off, #6 off
02/26/09	SBVMWD	45.90	867.32	#2 off, #3 off, #4 off, #6 off
03/04/09	Watermaster	47.86	865.36	#2 off, #3 off, #4 off, #6 off
03/04/09	City of Riverside	47.88	865.34	
03/23/09	SBVMWD	61.50	851.72	#2 on, #3 on, #4 on, #6 on
04/01/09	Watermaster	63.66	849.56	#2 on, #3 on, #4 on, #6 on
04/15/09	SBVMWD	67.40	845.82	#2 on, #3 on, #4 on, #6 on
05/06/09	Watermaster	70.53	842.69	#2 on, #3 on, #4 on, #6 off
05/07/09	City of Riverside	70.51	842.71	Nearby pumping
05/14/09	SBVMWD	71.80	841.42	#2 on, #3 on, #4 on, #6 off
05/14/09	City of Riverside	71.83	841.39	Nearby pumping
06/03/09	Watermaster	77.59	835.63	#2 on, #3 on, #4 on, #6 on
06/16/09	SBVMWD	79.50	833.72	#2 on, #3 on, #4 on, #6 on
06/18/09	City of Riverside	79.58	833.64	Nearby pumping
07/01/09	Watermaster	81.18	832.04	#2 on, #3 on, #4 on, #6 on
07/15/09	City of Riverside	82.40	830.82	Nearby pumping
07/20/09	SBVMWD	82.90	830.32	#2 on, #3 on, #4 on, #6 on
08/05/09	Watermaster	84.62	828.60	#2 on, #3 on, #4 on, #6 on
08/19/09	City of Riverside	85.97	827.25	Nearby pumping
08/27/09	SBVMWD	80.10	833.12	#2 on, #3 on, #4 on, #6 on
09/02/09	Watermaster	87.30	825.92	#2 on, #3 on, #4 on, #6 on
09/18/09	City of Riverside	88.72	825.47	#2 on, #3 on, #4 on, #6 on
09/27/09	SBVMWD	87.09	826.13	#2 on, #3 on, #4 on, #6 off
10/02/09	City of Riverside	88.24	825.95	Nearby pumping
10/08/09	Watermaster	88.58	824.64	#2 on, #3 on, #4 on, #6 off
10/08/09	City of Riverside	88.56	825.63	#2 on, #3 on, #4 on, #6 off
10/09/09	City of Riverside	87.14	827.05	All Flume wells off (LOW)
10/09/09	Watermaster	87.30	825.92	#2 off, #3 off, #4 off, #6 off
10/15/09	City of Riverside	86.50	827.69	#2 on, #3 off, #4 off, #6 off
10/19/09	City of Riverside	84.24	829.29	#2 on, #3 off, #4 off, #6 off
10/20/09	City of Riverside	85.08	829.50	#2 on, #3 off, #4 off, #6 off
11/04/09	City of Riverside	88.57	826.01	#2 on, #3 on, #4 on
11/04/09	Watermaster	86.92	826.61	#2 on, #3 on, #4 on, #6 off
11/19/09	City of Riverside	87.56	825.97	#2 on, #3 on, #4 on, #6 on
12/02/09	Watermaster	84.13	829.40	#2 on, #3 off, #4 off, #6 off
12/04/09	City of Riverside	83.69	829.84	#2 on, #3 off, #4 off, #6 off

**Western San Bernardino Watermaster
Well Measurement Record for**

Flume #5

State Well Number 1S/4W29Q01S

Basin: Riverside North Reference Point Elevation: 916.53
 Reference Point #2 Elevation: 913.22
 Reference Point #3 Elevation: 913.53
Reference Point #4 Elevation: 913.448
 Reference Point #4a Elevation: 914.622
 Reference Point #5 Elevation: 916.04 see note in comment box

Date	Obtained from	Ref. Pt to Water	Water Surface Elevation	Remarks
2010				
01/06/10	Watermaster	76.94	836.59	#2 on, #3 on, #4 on, #6 off
01/06/10	City of Riverside	76.91	836.54	#2 on, #3 on, #4 on, #6 off
01/15/10	City of Riverside	80.19	834.43	
01/29/10	City of Riverside	60.71	852.74	
02/03/10	Watermaster	64.08	849.45	#2 off, #3 off, #4 off, #6 off
02/10/10	City of Riverside	57.10	856.35	
03/03/10	Watermaster	57.54	855.99	#2 off, #3 on, #4 on, #6 off
03/11/10	City of Riverside	55.16	858.29	
03/16/10	City of Riverside	59.57	853.88	
04/07/10	Watermaster	69.10	844.43	#2 on #3 on, #4 on, #6 off
05/05/10	Watermaster	71.43	842.10	#2 on #3 on, #4 on, #6 off
05/12/10	City of Riverside	74.12	840.50	
06/02/10	Watermaster	76.38	837.15	#2 on #3 on, #4 on, #6 off
06/21/10	City of Riverside	79.22	834.23	
07/07/10	Watermaster	81.19	832.34	#2 on #3 on, #4 on, #6 off
07/15/10	City of Riverside	83.19	831.43	
08/04/10	Watermaster	83.10	830.43	#2 on #3 on, #4 on, #6 off
09/01/10	Watermaster	97.99	815.54	#2 on #3 on, #4 on, #6 off
10/05/10	City of Riverside	89.80	824.82	
10/06/10	Watermaster	88.36	825.17	#2 on, #3 on, #4 off, #6 off
10/27/10	City of Riverside	88.34	826.28	#2 off #3 on, #4 off, #6 off
11/03/10	Watermaster	85.30	828.15	#2 off, #3 off, #4 off, #6 off LOW
11/03/10	City of Riverside	85.28	828.17	All Flume wells off 4 day
12/08/10	City of Riverside	79.76	834.86	All Flume wells off
12/01/10	Watermaster	79.58	835.04	
2011				
01/05/11	Watermaster	60.18	853.27	
01/31/11	City of Riverside	64.38	849.07	All Flume wells off
02/02/11	Watermaster	64.54	848.91	All Flume wells off
02/14/11	City of Riverside	64.61	848.84	All Flume wells off
03/02/11	Watermaster	53.81	859.64	All Flume wells off
03/20/11	City of Riverside	61.32	852.13	
04/06/11	Watermaster	46.16	867.29	All Flume wells off
04/19/11	City of Riverside	54.64	858.81	
05/04/11	Watermaster	48.70	864.75	All Flume wells off
05/31/11	City of Riverside	59.93	853.52	
06/01/11	Watermaster	60.20	853.25	#2 on, #3 on, #4 on, #6 off
06/29/11	City of Riverside	68.28	845.17	
07/06/11	Watermaster	68.67	844.78	#2 on, #3 on, #4 on, #6 off
07/31/11	City of Riverside	75.20	838.25	
08/18/11	Watermaster	76.25	837.20	#2 on, #3 on, #4 on, #6 off
08/31/11	City of Riverside	79.49	833.96	
09/07/11	Watermaster	80.66	832.79	#2 on, #3 on, #4 on, #6 on
09/30/11	City of Riverside	83.81	829.64	
10/05/11	Watermaster	84.50	828.95	#2 on, #3 on, #4 on, #6 on
10/30/11	City of Riverside	86.52	826.93	
11/02/11	Watermaster	83.94	829.51	All Flume wells off LOW
11/02/11	City of Riverside	83.82	829.63	

**Western San Bernardino Watermaster
Well Measurement Record for**

Flume #5

State Well Number 1S/4W29Q01S

Basin: Riverside North Reference Point Elevation: 916.53
 Reference Point #2 Elevation: 913.22
 Reference Point #3 Elevation: 913.53
Reference Point #4 Elevation: 913.448
 Reference Point #4a Elevation: 914.622
 Reference Point #5 Elevation: 916.04 see note in comment box

Date	Obtained from	Ref. Pt to Water	Water Surface Elevation	Remarks
12/07/11	Watermaster	85.29	828.158	
2012				
01/04/12	Watermaster	86.61	826.838	#2 on, #3 on, #4 on, #6 off
01/13/12	City of Riverside	87.08	826.37	
02/01/12	Watermaster	87.30	826.15	#2 on, #3 on, #4 on, #6 off
02/10/12	City of Riverside	87.67	825.78	
03/07/12	Watermaster	88.07	825.38	#2 on, #3 on, #4 on, #6 off
03/22/12	City of Riverside	85.50	827.95	
04/04/12	Watermaster	83.38	830.07	#2 on, #3 off #4 on, #6 off
04/16/12	City of Riverside	83.53	829.92	
05/02/12	Watermaster	84.14	829.31	#2 on, #3 on, #4 on, #6 off
05/14/12	City of Riverside	85.18	828.27	
06/06/12	Watermaster	88.52	824.93	#2 on, #3 on, #4 on, #6 off
06/13/12	City of Riverside	88.71	824.74	
07/11/12	Watermaster	91.62	821.83	#2 on, #3 on, #4 on, #6 off
07/14/12	City of Riverside	91.84	821.61	
08/01/12	Watermaster	95.02	818.43	#2 on, #3 on, #4 on, #6 on
08/13/12	City of Riverside	96.30	817.15	
09/05/12	Watermaster	98.32	815.13	#2 on, #3 on, #4 on, #6 on
09/13/12	City of Riverside	98.88	814.57	
10/10/12	Watermaster	101.00	812.45	
10/29/12	City of Riverside	101.30	812.15	
11/14/12	Watermaster	101.35	812.10	
11/16/12	Watermaster	100.88	812.57	#2 off, #3 on, #4 off, #6 off, #7 on
11/16/12	City of Riverside	100.82	812.63	Low for year
12/12/12	City of Riverside	100.50	812.95	All Flume wells off +23 hours - LOW
12/12/12	Watermaster	100.28	813.168	
12/13/12	City of Riverside	99.42	814.028	All Flume wells off +45 hours
12/13/12	Watermaster	99.47	813.978	Storm event peaked at E St Gage 1500 cfs on morning c
12/14/12	City of Riverside	98.56	814.888	All Flume wells off +66 hours
12/14/12	Watermaster	98.61	814.838	
12/17/12	City of Riverside	94.96	818.488	All Flume wells off +138 hours
12/17/12	Watermaster	95.01	818.438	
2013				
01/09/13	Watermaster	88.66	824.79	#2 off, #3 off, #4 off, #6 off, #7 off
01/30/13	City of Riverside	85.80	827.65	Preliminary transducer data
02/13/13	Watermaster	83.93	829.52	#2 off, #3 off, #4 off, #6 off, #7 off
02/28/13	City of Riverside	82.51	830.94	Preliminary transducer data
03/13/13	Watermaster	82.67	830.78	#2 on #3 off, #4 off, #6 off, #7 on
03/30/13	City of Riverside	86.51	826.94	Preliminary transducer data
04/10/13	Watermaster	89.51	823.94	#2 on, #3 on, #4 on, #6 off, #7 ?
04/30/13	City of Riverside	93.42	820.03	Preliminary transducer data
05/08/13	Watermaster	94.58	818.87	#2 on, #3 on, #4 on, #6 off, #7 on
05/30/13	City of Riverside	97.61	815.84	Preliminary transducer data
06/14/13	Watermaster	99.42	814.03	#2 on, #3 on, #4 on, #6 off, #7 on
06/30/13	City of Riverside	101.03	812.42	Preliminary transducer data
07/10/13	Watermaster	101.88	811.57	#2 on, #3 on, #4 on, #6 off, #7 on
07/30/13	City of Riverside	102.73	810.72	Preliminary transducer data

**Western San Bernardino Watermaster
Well Measurement Record for**

Flume #5

State Well Number 1S/4W29Q01S

Basin: Riverside North Reference Point Elevation: 916.53
 Reference Point #2 Elevation: 913.22
 Reference Point #3 Elevation: 913.53
Reference Point #4 Elevation: 913.448
 Reference Point #4a Elevation: 914.622
 Reference Point #5 Elevation: 916.04 see note in comment box

Date	Obtained from	Ref. Pt to Water	Water Surface Elevation	Remarks
08/14/13	Watermaster	103.40	810.05	#2 on, #3 on, #4 on, #6 off , #7 on
08/30/13	City of Riverside	104.16	809.29	Preliminary transducer data
09/10/13	Watermaster	103.84	809.61	#2 on, #3 on, #4 on, #6 off , #7 on
09/30/13	City of Riverside	104.94	808.51	
10/09/13	Watermaster	105.38	808.07	#2 on, #3 on, #4 on, #6 off , #7 on
10/30/13	City of Riverside	105.47	807.98	Preliminary transducer data
11/13/13	Watermaster	105.98	807.47	Pumping; #2 on, #3 on, #4 on, #6 off , #7 on
11/27/13	City of Riverside	102.61	810.84	Manual read; all Flume wells off within last hour
11/27/13	Watermaster	102.69	810.76	All wells off at approximately 1100 hr 11/27/13
12/02/13	City of Riverside	100.45	813.00	Manual read, Flume wells off for 119 hours
12/02/13	Watermaster	100.50	812.95	All wells off / LOW
12/11/13	Watermaster	102.64	810.81	Off; #2 off, #3 on, #4 on, #6 off , #7 on